

DIMENSIONS FOR 3 POSTION SHOWN

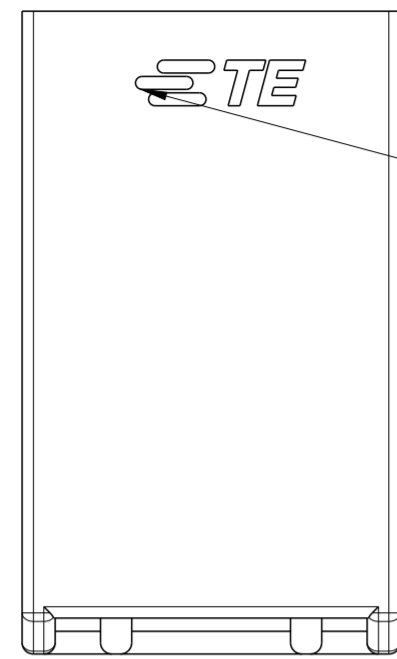

TRADE MARK

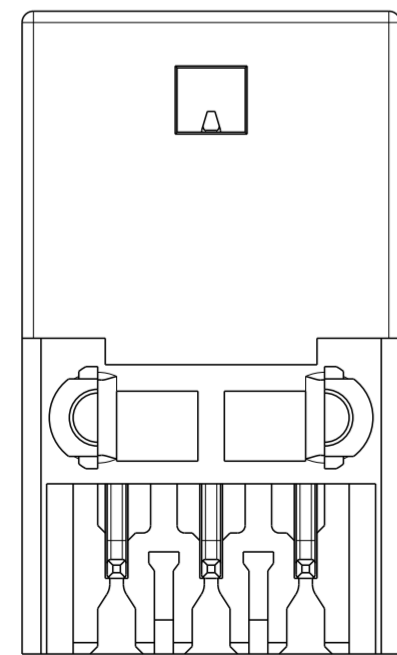
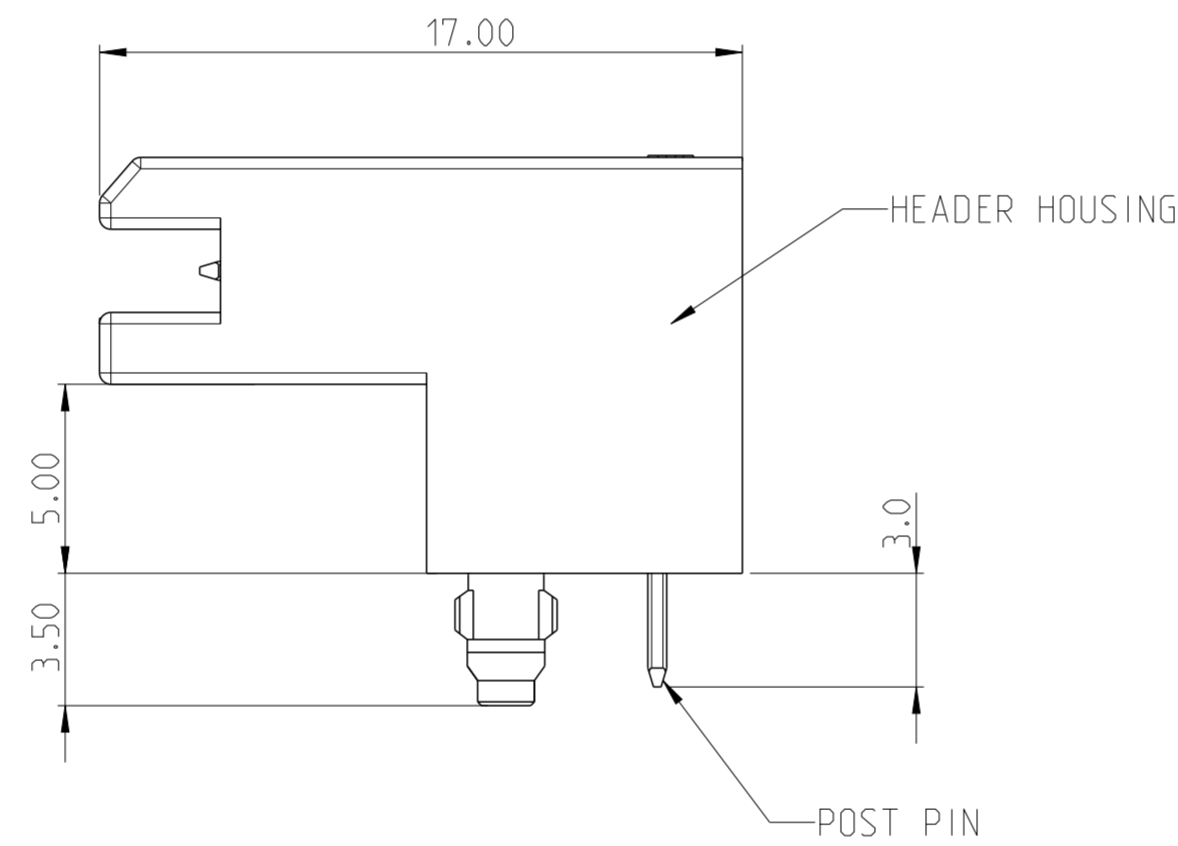
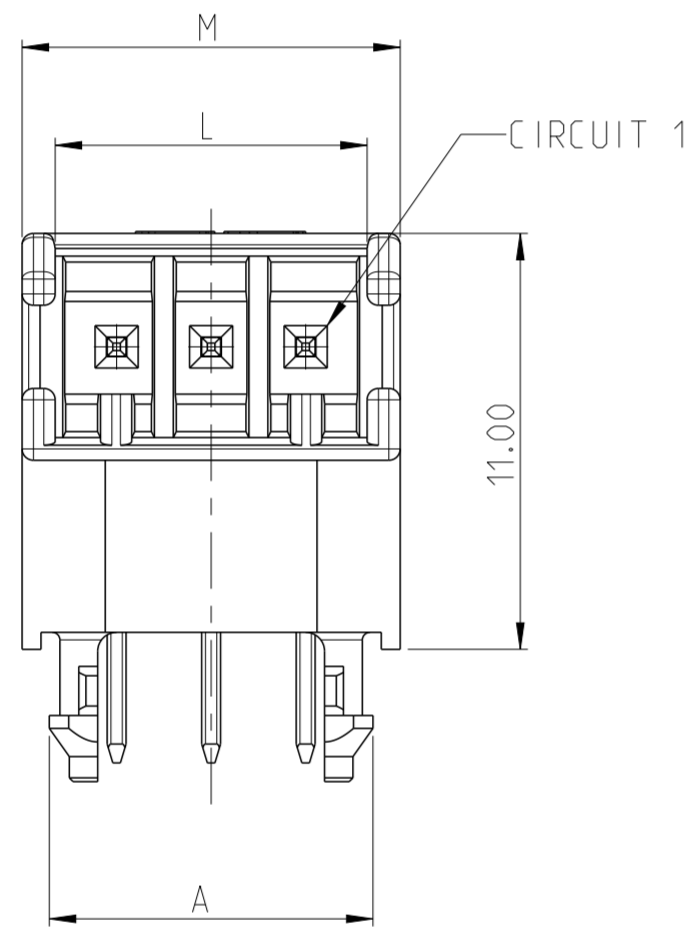
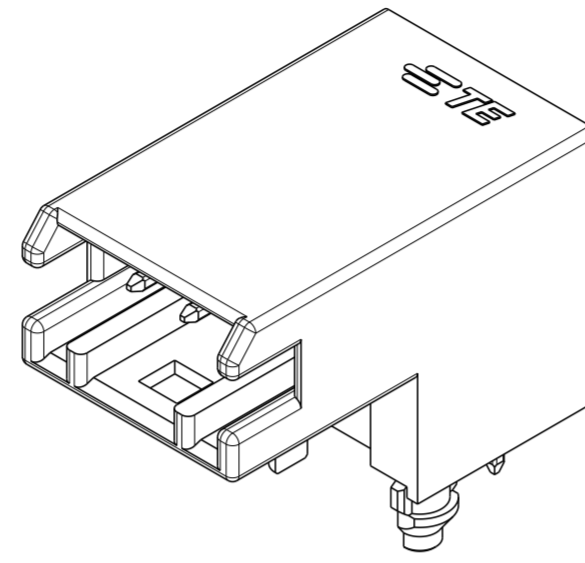

REVISIONS					
P	LTR	DESCRIPTION	DATE	DWN	APVD
A		RELEASED PER ECN-22-187907	02DEC2022	CX	DZ
A1		REVISED PER ECR-23-182831	02AUG2023	AN	CX
B		REVISED PER ECN-25-360152	10FEB2026	CM	CD

- 1 MATERIAL:
 HEADER HOUSING: THERMOPLASTIC, PA66;
 POST PIN: BRASS, PRE-TIN
- 2. RECOMMENDED MATING PART SEE TABLE.
- 3. PER IEC 60335-1 SECT. 30, GWEPT 750C, NO FLAME or Te-Ti LESS THAN 2SEC.
- 4. ONLY FOR POTTING APPLICATION. POTTING HEIGHT: 4.0MM MAX.
- 5 PRELIMINARY PART - NOT RELEASED FOR PRODUCTION. THIS PRODUCT HAS NOT COMPLETED QUALIFICATION TESTING

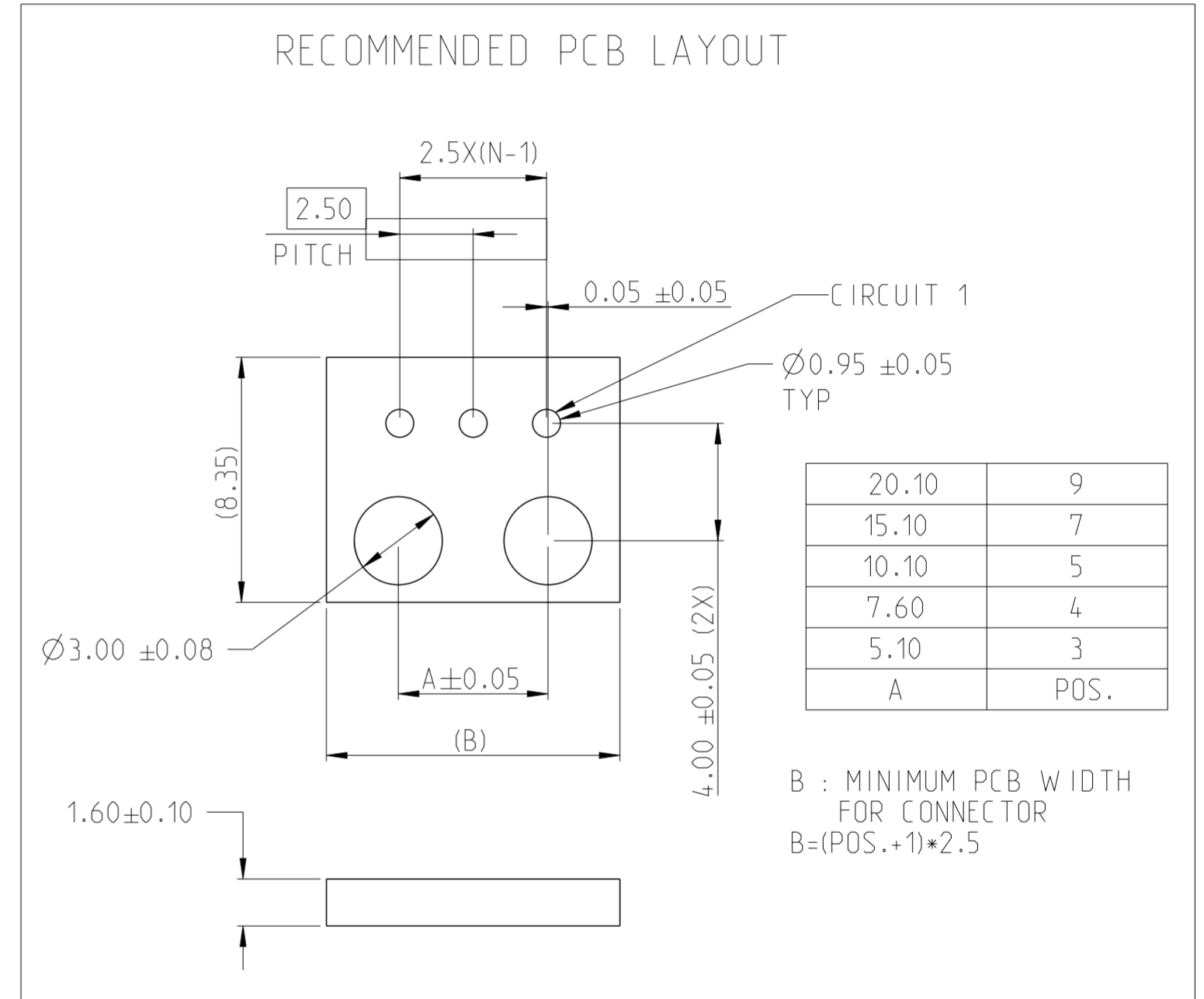

1376477-9	23.56	25.00	23.25	NATURAL	9	2368182-9
1376477-7	18.56	20.00	18.25	NATURAL	7	2368182-7
1-1376477-5	13.56	15.00	13.25	RED	5	1-2368182-5
1376477-5	13.56	15.00	13.25	NATURAL	5	2368182-5
2-1376477-4	11.06	12.50	10.75	BLUE	4	2-2368182-4
1376477-4	11.06	12.50	10.75	NATURAL	4	2368182-4
1-1376477-3	8.56	10.00	8.25	RED	3	1-2368182-3
1376477-3	8.56	10.00	8.25	NATURAL	3	2368182-3
MATING PART	A	M	L	COLOR	POSITION	PART NO.

THIS DRAWING IS A CONTROLLED DOCUMENT.

DIMENSIONS: mm	TOLERANCES UNLESS OTHERWISE SPECIFIED:	DWN C.XU 26-FEB-20	TE Connectivity NAME: HEADER ASSEMBLY, RIGHT ANGLE, POTTING VERSION, SMC2.5
	0 PLC ±	CHK D.ZHANG 26-FEB-20	
	1 PLC ±0.20	APVD D.ZHANG 26-FEB-20	
	2 PLC ±0.15	PRODUCT SPEC 108-5703	
MATERIAL	4 PLC ±	APPLICATION SPEC 114-5286	SIZE A2
	ANGLES ±	WEIGHT -	CAGE CODE 00779
	FINISH	CUSTOMER DRAWING	DRAWING NO. C-2368182
		SCALE 5:1	SHEET 1 OF 2
		REV B	

REVISIONS				
P	LTR	DESCRIPTION	DATE	APVD
		SEE SHEET 1		

OTHER POSITIONS SHOWN

3P

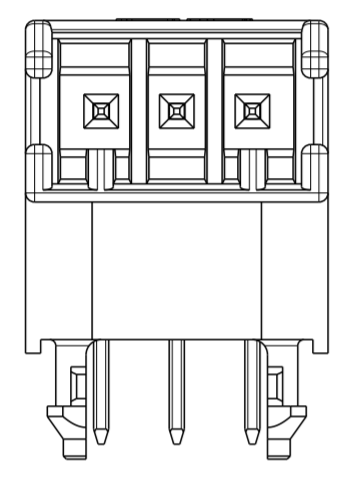

4P

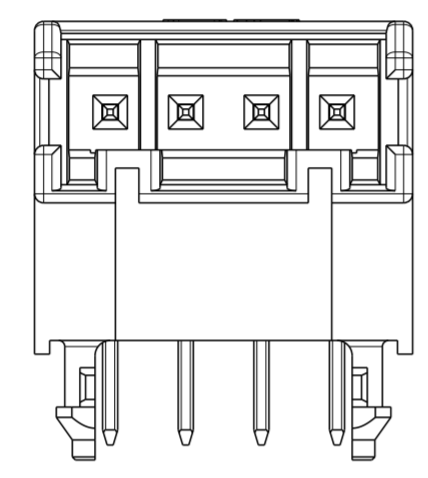

5P

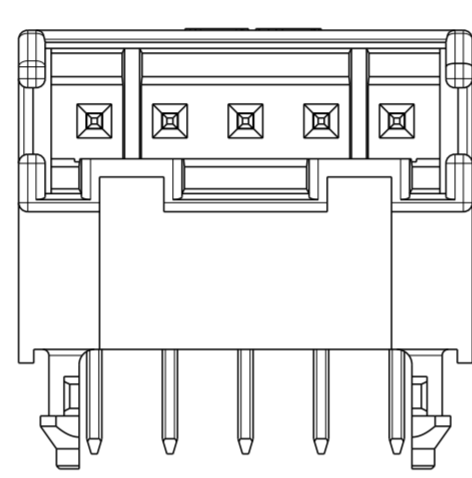

7P

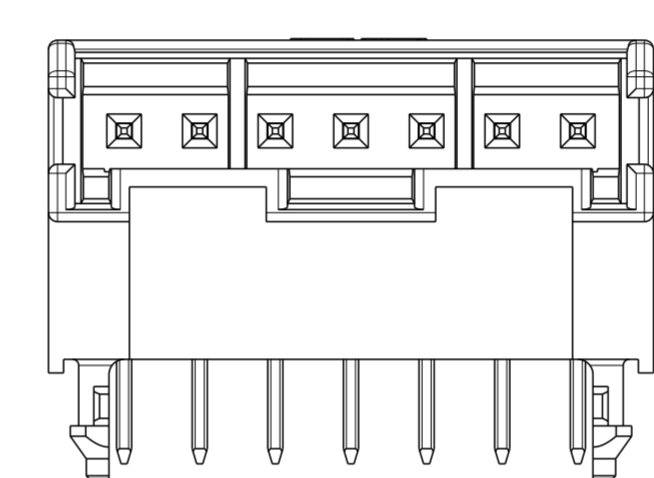

9P

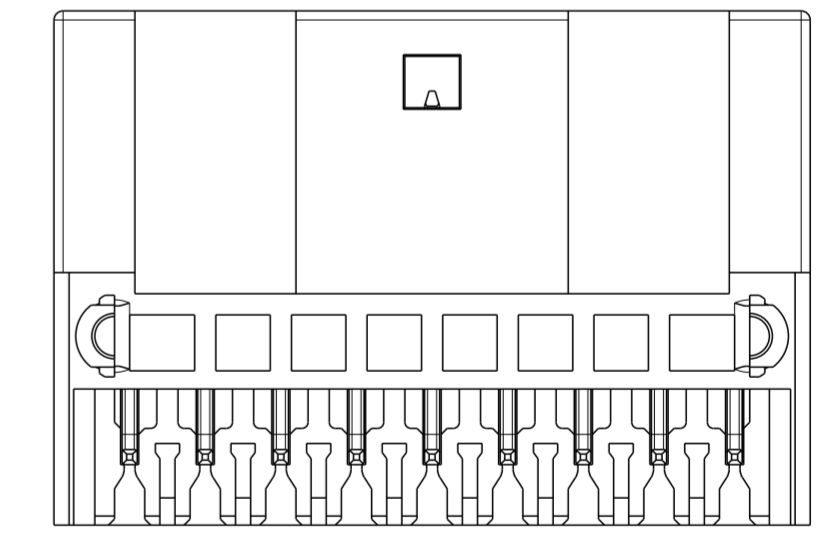
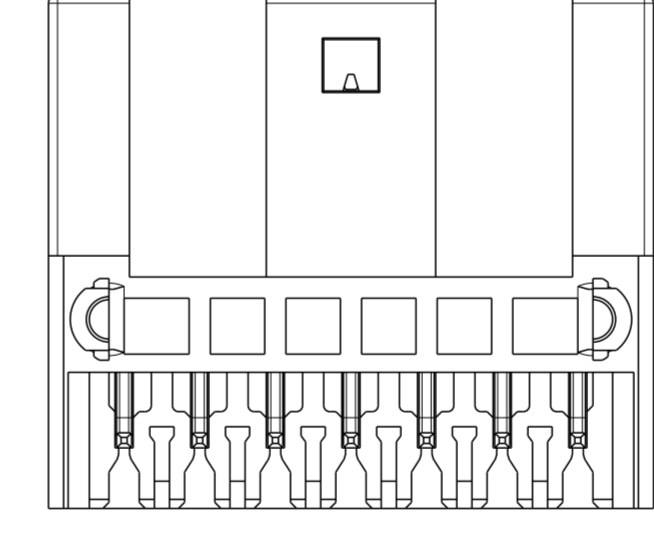
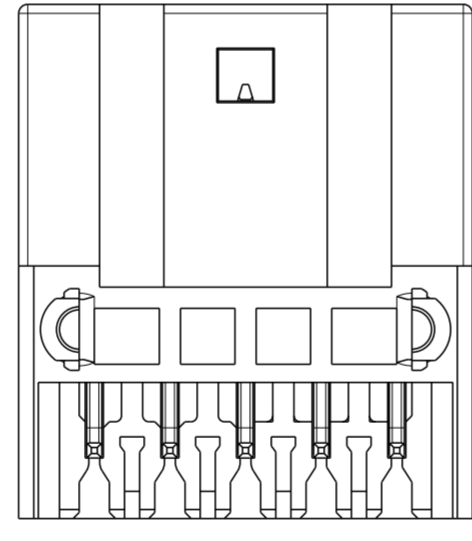
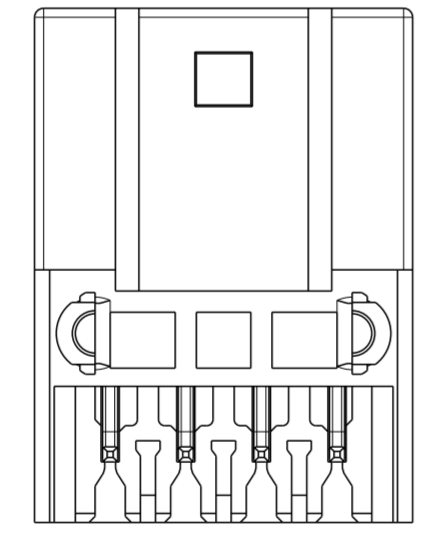
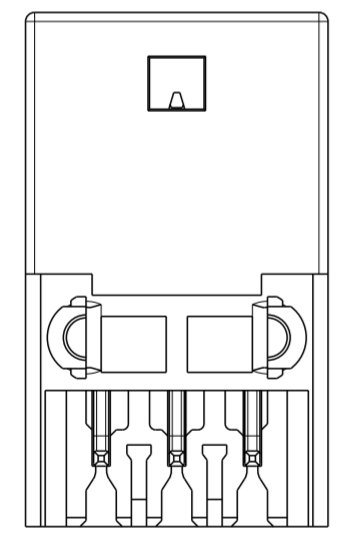
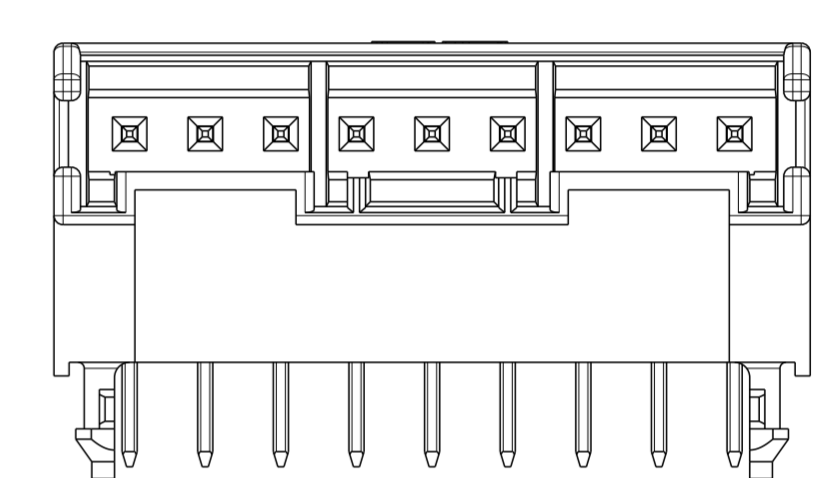

THIS DRAWING IS A CONTROLLED DOCUMENT.		DWN C.XU 26-FEB-20		
DIMENSIONS: mm		CHK D.ZHANG 26-FEB-20		
TOLERANCES UNLESS OTHERWISE SPECIFIED:		APVD D.ZHANG 26-FEB-20	NAME HEADER ASSEMBLY, RIGHT ANGLE, POTTING VERSION, SMC2.5	
0 PLC ± 1 PLC ±0.20 2 PLC ±0.15 3 PLC ± 4 PLC ± ANGLES ± FINISH 1		PRODUCT SPEC 108-5703	SIZE A2	CAGE CODE 100779
MATERIAL		APPLICATION SPEC -	DRAWING NO C-2368182	RESTRICTED TO -
		WEIGHT -	SCALE 5:1	SHEET 2 OF 2
		CUSTOMER DRAWING	REV B	