

SERIES: VAT2-SMT | **DESCRIPTION:** DC-DC CONVERTER

FEATURES

- 2 W isolated output
- industry standard 14 pin SMT package
- dual unregulated outputs
- 1,000 Vdc isolation
- short circuit protection
- wide temperature (-40~105°C)
- efficiency up to 85%

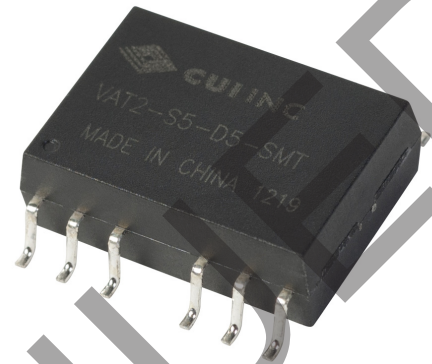

MODEL

MODEL	input voltage		output voltage (Vdc)	output current		output power max (W)	ripple and noise ¹ max (mVp-p)	efficiency typ (%)
	typ (Vdc)	range (Vdc)		min (mA)	max (mA)			
VAT2-S5-D5-SMT*	5	4.5~5.5	±5	±20	±200	2	150	82
VAT2-S5-D9-SMT*	5	4.5~5.5	±9	±12	±111	2	150	83
VAT2-S5-D12-SMT	5	4.5~5.5	±12	±9	±83	2	150	84
VAT2-S5-D15-SMT*	5	4.5~5.5	±15	±7	±67	2	150	82
VAT2-S12-D5-SMT*	12	10.8~13.2	±5	±20	±200	2	150	83
VAT2-S12-D9-SMT*	12	10.8~13.2	±9	±12	±111	2	150	84
VAT2-S12-D12-SMT*	12	10.8~13.2	±12	±9	±83	2	150	84
VAT2-S12-D15-SMT*	12	10.8~13.2	±15	±7	±67	2	150	85

Notes: 1. Ripple and noise are measured at 20 MHz BW by "parallel cable" method with 1 µF ceramic and 10 µF electrolytic capacitors on the output.
*. Discontinued

PART NUMBER KEY

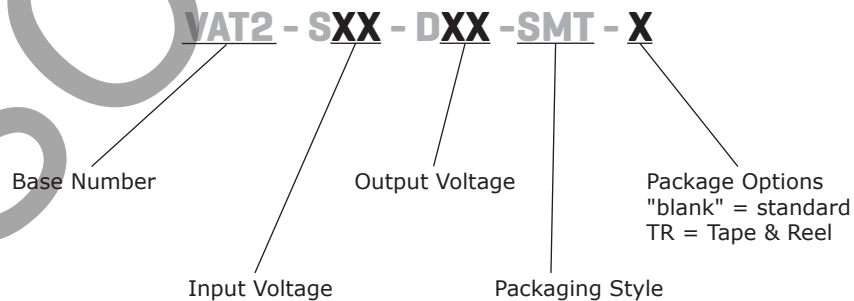

INPUT

parameter	conditions/description	min	typ	max	units
operating input voltage	5 Vdc model	4.5	5	5.5	Vdc
	12 Vdc model	10.8	12	13.2	Vdc

OUTPUT

parameter	conditions/description	min	typ	max	units
line regulation	for Vin change of 1%			±1.2	%
load regulation	measured from 10% load to full load	5 Vdc models	12.8	15	%
		9 Vdc models	8.3	10	%
		12 Vdc models	6.8	10	%
		15 Vdc models	6.3	10	%
voltage accuracy	see derating curves				
switching frequency	100% load		70		kHz
temperature coefficient	100% load			±0.03	%/°C

PROTECTIONS

parameter	conditions/description	min	typ	max	units
short circuit protection				1	s

SAFETY AND COMPLIANCE

parameter	conditions/description	min	typ	max	units
isolation voltage	input to output for 1 minute at 1 mA max.	1,000			Vdc
isolation resistance	input to output at 500 Vdc	1,000			MΩ
conducted emissions	CISPR22/EN55022, class A (external circuit required, see Figure 1)				
ESD	IEC/EN 61000-4-2, class B, contact ±6kV				
MTBF	as per MIL-HDFK-217 at 25 °C	3,500,000			hours
RoHS	2011/65/EU				

ENVIRONMENTAL

parameter	conditions/description	min	typ	max	units
operating temperature	see derating curve	-40		105	°C
storage temperature		-55		125	°C
storage humidity	non-condensing			95	%
temperature rise	at full load		25		°C
reflow soldering	see reflow soldering profile			245	°C

WAVE SOLDERING PROFILE

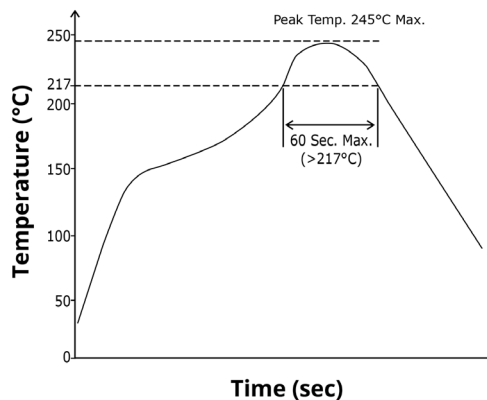

MECHANICAL

parameter	conditions/description	min	typ	max	units
dimensions	17.78 x 12.70 x 6.00 (0.700 x 0.500 x 0.236 inch)				mm
case material	plastic (UL94-V0)				
weight			2.1		g

MECHANICAL DRAWING

units: mm [inches]
 tolerance: ± 0.25 [± 0.010]
 pin section tolerance: ± 0.10 [± 0.004]

PIN CONNECTIONS	
PIN	FUNCTION
1	GND
2	+Vin
5	-Vo
6	0 V
7	+Vo
10	-Vo
others	NC

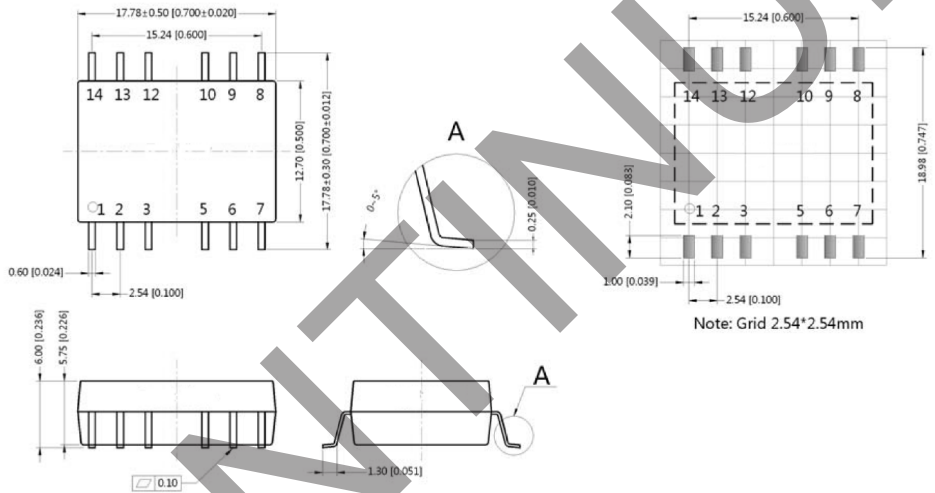

DERATING CURVES

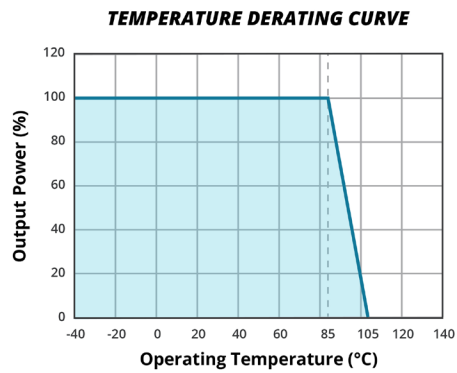
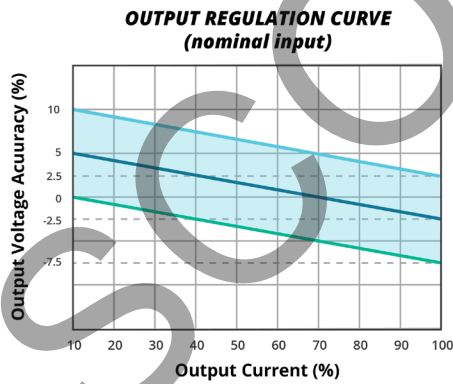

EMC RECOMMENDED CIRCUIT

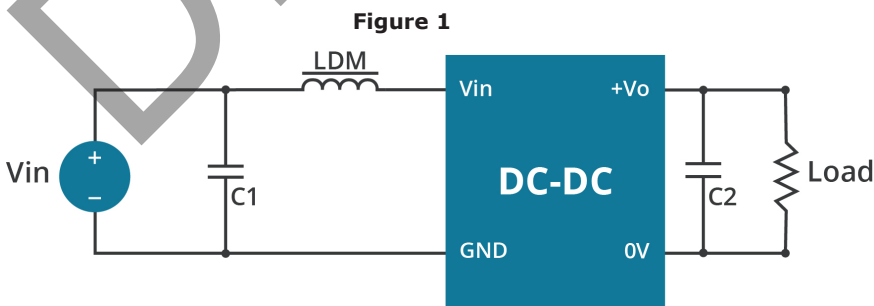

Table 1
Recommended external circuit components

Vout (Vdc)	C1	C2
5	2.2µF/50V	4.7µF
9	2.2µF/50V	2.2µF
12	2.2µF/50V	1µF
15	2.2µF/50V	0.47µF

APPLICATION NOTES

1. Output load requirement

To ensure this module can operate efficiently and reliably, the minimum output load may not be less than 10% of the full load during operation. If the actual output power is low, connect a resistor at the output end in parallel to increase the load.

2. Overload Protection

Under normal operating conditions, the output circuit of this product has no protection against overload. The simplest method to add this is to add a circuit breaker to the circuit.

3. Recommended circuit

If you want to further decrease the input/output ripple, you can increase the capacitance accordingly or choose capacitors with low ESR (see Figure 2 & Table 2). However, the capacitance of the output filter capacitor must be appropriate. If the capacitance is too high, a startup problem might arise. For every channel of the output, to ensure safe and reliable operation, the maximum capacitance must be less than the maximum capacitive load (see Table 3).

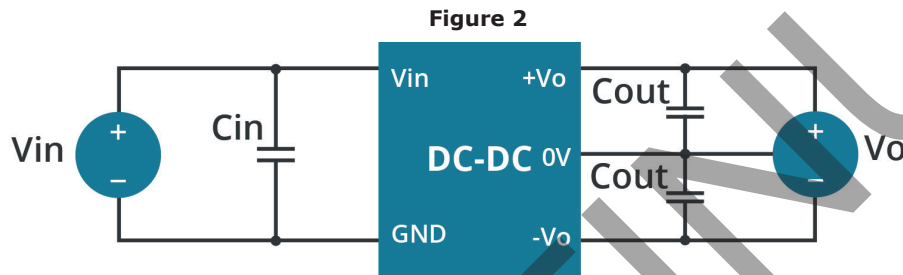

Table 2

Vin (Vdc)	Cin (μF)	Dual Vo (Vdc)	Cout (μF)
5	4.7	±5	4.7
12	2.2	±9	2.2
-	-	±12	1
-	-	±15	0.47

Table 3

Dual Vout (Vdc)	Max. Capacitive Load ¹ (μF)
5	100
9	100
12	100
15	100

Note: It's not recommended to connect any external capacitors in applications with less than 0.5 watt output.

Note: 1. For each output.

4. Output Voltage Regulation and Over-voltage Protection Circuit

The device for output voltage regulation, over-voltage and over-current protection is a linear regulator and a capacitor filtering network with overheat protection which can be connected to the input or output end in series (see Figure 3). The recommended capacitance of its filter capacitor (see Table 3), and the linear regulator is based on the actual voltage and current required.

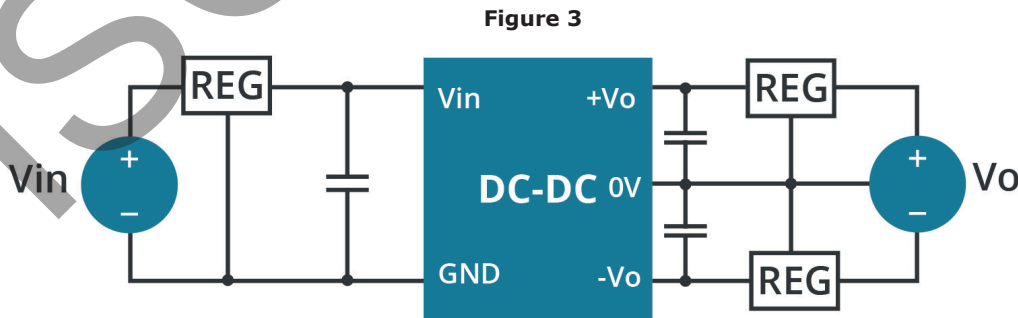

Note: 1. Operation under minimum load will not damage the converter; however, they may not meet all specifications listed.

2. Max. capacitive load tested at input voltage range and full load.

3. It is recommended to use either ceramic capacitors or electrolytic capacitors on the input and the output. Using tantalum capacitors may increase the risk of failure.

4. All specifications measured at: Ta=25°C, humidity<75%, nominal input voltage and rated output load, unless otherwise specified.

REVISION HISTORY

rev.	description	date
1.0	initial release	02/11/2008
1.01	new template applied	04/20/2012
1.02	V-Infinity branding removed	09/04/2012
1.03	added TR package option	11/01/2012
1.04	reflow solder profile changed	05/25/2014
1.05	updated datasheet	03/30/2015
1.06	discontinued VAT2-S5-D9-SMT, VAT2-S12-D5-SMT, & VAT2-S12-D9-SMT models	10/30/2018
1.07	discontinued model VAT2-S12-D12-SMT	12/14/2018
1.08	data update	01/08/2020
1.09	discontinued model VAT2-S12-D15-SMT; logo update	06/18/2020
1.10	discontinued model VAT2-S5-D15-SMT & VAT2-S5-D5-SMT	04/27/2021
1.11	derating curves and circuit figures updated	07/13/2021

The revision history provided is for informational purposes only and is believed to be accurate.



Headquarters
20050 SW 112th Ave.
Tualatin, OR 97062
800.275.4899

Fax 503.612.2383
cui.com
techsupport@cui.com

CUI offers a two (2) year limited warranty. Complete warranty information is listed on our website.

CUI reserves the right to make changes to the product at any time without notice. Information provided by CUI is believed to be accurate and reliable. However, no responsibility is assumed by CUI for its use, nor for any infringements of patents or other rights of third parties which may result from its use.

CUI products are not authorized or warranted for use as critical components in equipment that requires an extremely high level of reliability. A critical component is any component of a life support device or system whose failure to perform can be reasonably expected to cause the failure of the life support device or system, or to affect its safety or effectiveness.

Please read our datasheet & drawing disclaimer [here](#).