

Fiber Optic Devices TOSLINK™

TOTU133 and TORU133 Fiber Optic Transmission Units for Automotive LAN Applications

The fiber optic transmission units, the TOTU133 and TORU133 are designed for automotive LAN applications for information systems. These devices draw on Toshiba's expertise in developing high-speed TOSLINK solutions to achieve the high reliability and in miniaturization and mass-production technologies. The TOTU133 transmitter incorporates a high-speed InGaP red LED and driver circuit, and the TORU133 receiver incorporates a photodiode and waveform-resaping circuit on a single chip. The interface is 3.3 V PECL for both the TOTU133 and TORU133, facilitating an easier connection with peripheral circuits.

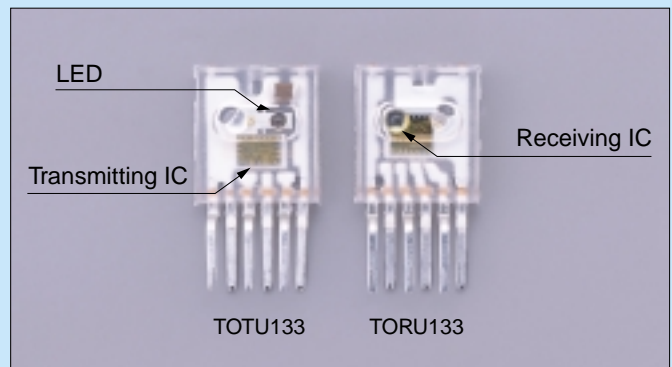

Package Dimensions and Pin Connections

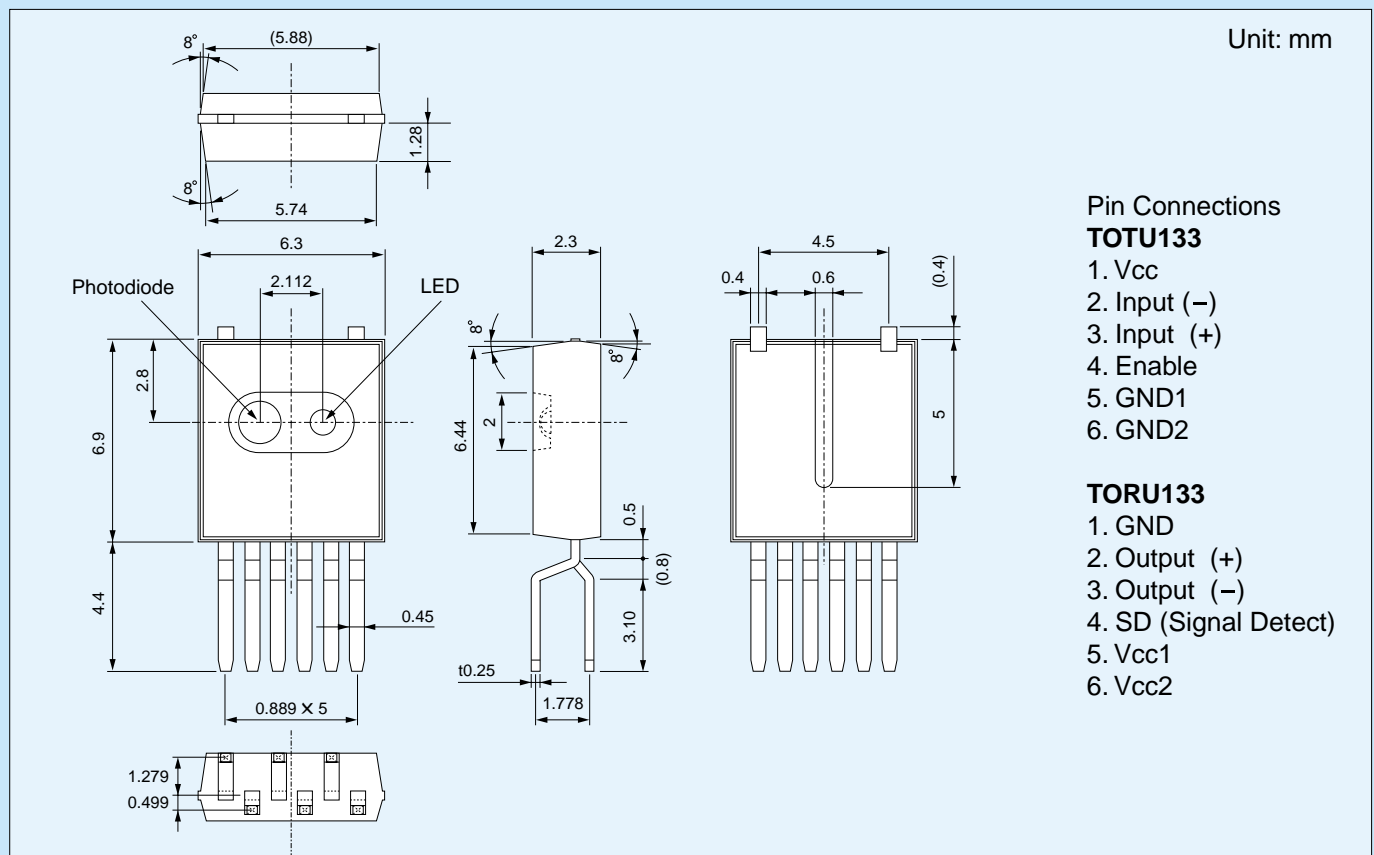

The products described in this product guide are intended for automotive LAN applications for information (or entertainment) systems. These products shall not be used in equipment whose malfunction or failure could have direct effects on the safety of the driver and/or passengers.

Maximum Ratings(Ta = 25°C)

Characteristics	Symbol	Rating	Unit
Storage temperature	Tstg	-40 to 85	°C
Operating temperature	Topr	-40 to 85	°C
Supply voltage	Vcc	-0.5 to 4.5	V
Output current (TORU133)	Io	50	mA
Soldering temperature	Tsol	260 ^(Note1)	°C

Note (1): Soldering time ≤ 3 s. Location: At least 1 mm away from the package

Recommended Operating Conditions

Characteristics	Symbol	Min	Typ.	Max	Unit
Supply voltage	Vcc	3.0	3.3	3.6	V
Data rate		20	-	125	Mb/s
Output load	RL	-	50	-	Ω
Mark ratio		-	50	-	%

Electrical and Optical Characteristics (TOTU133)

(Ta = 25°C, Vcc = 3.3 V)

Characteristics	Symbol	Test condition	Min	Typ.	Max	Unit
Date rate		NRZ code	20	-	125	Mb/s
Center wavelength	λc		-	650	-	nm
Fiber optic power ^(Note3)	Pf	Measured using APF ^(Note 2)	-7.0	-	-3.0	dBm, avg
Fiber optic power - High	Pf(H)		-4.0	-	0	dBm
Fiber optic power - Low	Pf(L)		-	-	-16.0	dBm
Current consumption	Icc		-	40	55	mA
Data input voltage - High	VIH		Vcc - 1.165	-	Vcc - 0.88	V
Data input voltage - Low	VIL		Vcc - 1.81	-	Vcc - 1.475	V
Enable input voltage - High ^(Note4)			Vcc X 0.8	-	-	V
Enable input voltage - Low ^(Note5)			-	-	Vcc X 0.2	V

Electrical and Optical Characteristics (TORU133)

(Ta = 25°C, Vcc = 3.3 V)

Characteristics	Symbol	Condition	Min	Typ.	Max	Unit
Date rate		NRZ code	20	-	125	Mb/s
Maximum receivable power ^(Note 6)	Pmax		0	-	-	dBm, avg
Minimum receivable power ^(Note 7)	Pmin	Measured using APF ^(Note 2) 125 Mb/s	-	-	-22.5	dBm, avg
Current consumption ^(Note 8)	Icc		-	45	55	mA
Data output voltage - High	VOH		Vcc - 1.045	-	Vcc - 0.88	V
Data output voltage - Low	VOL		Vcc - 1.84	-	Vcc - 1.62	V
Signal detect - Assert level ^(Note 9)		Measured using APF ^(Note 2)	-	-	-22.5	dBm, avg
Signal detect - Deassert level ^(Note 10)		Measured using APF ^(Note 2)	-	-	-23.5	dBm, avg
Signal detect output voltage - High			Vcc X 0.8	-	-	V
Signal detect output voltage - Low			-	-	Vcc X 0.2	V

Note Note 2: All Plastic Fiber (NA = 0.6, 980/1000 μm)

Note 3: Measured using standard optical fiber. Average power.

Note 4: The transmitter is on when the Enable input is high or open.

Note 5: The transmitter is off when the Enable input is low.

Note 6: 2⁷-1 pattern. Bit Error Ration (BER) ≤ 10⁻⁹. Average power.

Note 7: 2⁷-1 pattern. Eye opening ≤ 50%. Average power.

Note 8: This does not include the output load current.

Note 9: An increase in optical power through the specified level will cause the Signal Detect output to switch from low to high.

Note 10: A decrease in optical power through the specified level will cause the Signal Detect output to switch from high to low.

Temperature Characteristics

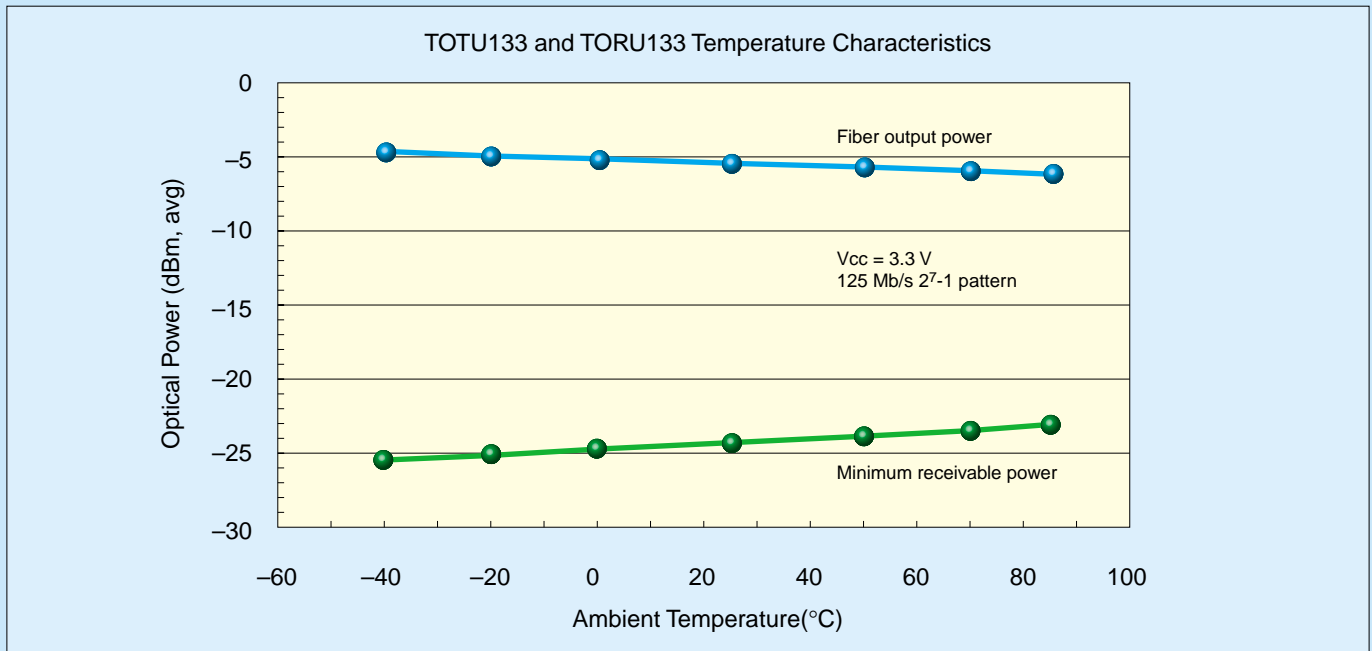

The graphs above are only shown as an example and are not intended to guarantee the characteristics.

Handling Precautions

Lifetime Characteristics

In fiber optic transmission units that have been in use for some time, nearly all of the deterioration in characteristics is due to a reduction in the fiber-output power (Pf). This is due to deterioration over time in the level of optical output of the LED used as the light source.

The drop in the LED's optical output is thought to be caused by crystal flaws in the wafer or stress in the mold resin, although the detailed causes are not clear.

The life of light-emitting devices is greatly affected by the operating conditions and operating environment as well as by the lifespan characteristics of the particular device. Toshiba recommends that the user first check a device's lifetime characteristics before selecting it and setting its operating conditions.

Regular maintenance, such as a check on the amount of light emitted is recommended.

Noise Resistance

To operate the fiber optic transmission units normally, they must be enclosed in a conductive case. The case for the units is made of conductive material and should be grounded to provide shielding effectiveness. Also, the case potential must be the same as for the SIGNAL-GND.

In some environments, simply shielding the case will not protect against noise. When using the fiber optic transmission units, conduct live tests to check noise resistance.

Application Ranges

The fiber optic transmission units described in this product guide are intended for use in entertainment information systems (e.g., car audio systems, navigation systems with no information that could affect the safety). These products shall not be used in equipment whose malfunction or failure could have direct effects on the safety of the driver and/or passengers.

Application Precautions

TOSHIBA is continually working to improve the quality and reliability of its products. Nevertheless, semiconductor devices in general can malfunction or fail due to their inherent electrical sensitivity and vulnerability to physical stress. It is the responsibility of the buyer, when utilizing TOSHIBA products, to comply with the standards of safety in making a safe design for the entire system, and to avoid situations in which a malfunction or failure of such TOSHIBA products could cause loss of human life, bodily injury or damage to property. In developing your designs, please ensure that TOSHIBA products are used within specified operating ranges as set forth in the most recent TOSHIBA products specifications. Also, please keep in mind the precautions and conditions set forth in the "Handling Guide for Semiconductor Devices," or "TOSHIBA Semiconductor Reliability Handbook" etc..

TODX2404 500 Mb/s Optical Transceiver for SMI Connector

- Designed for Small Multimedia Interface (SMI) optical connector
 - Data rate: Up to 500 Mb/s
 - Transmission distance: Up to 10 m @500 Mb/s
Up to 20 m @250 Mb/s
Up to 50 m @125 Mb/s
 - 650 nm RC-LED
 - Supply voltage: 3.3 ± 0.3 V
 - PECL interface
 - Operating temperature: 0 to 60 °C
 - Resin molded package
- Applications**
- IEEE1394.b (S400, S200, S100) and others



TODX2402 250 Mb/s Optical Transceiver for SMI Connector

- Designed for Small Multimedia Interface (SMI) optical connector
 - Data rate: Up to 250 Mb/s
 - Transmission distance: Up to 20 m @250 Mb/s
Up to 50 m @125 Mb/s
 - 650 nm LED
 - Supply voltage: 3.3 ± 0.3 V
 - PECL interface
 - Operating temperature: 0 to 60 °C (250 Mb/s)
-10 to 70 °C (125 Mb/s)
 - Resin molded package
- Applications**
- First Ethernet
 - IEEE1394.b (S200, S100) and others



TOTX142L and TORX142L High-Speed Optical Modules for Digital Audio Applications

Designed for digital audio systems with 192 kHz sampling frequency

- Data rate: Up to 25 Mb/s
- Transmission distance: Up to 5 m
- Fiber output power: -21 to -15dBm
- Minimum receivable power: -24dBm (max)
- 650 nm LED
- Supply voltage: 3.0 to 3.6 V
- Operating temperature: -20 to 70 °C
- Integrated shutter

Applications

- DVD-Audio systems and others

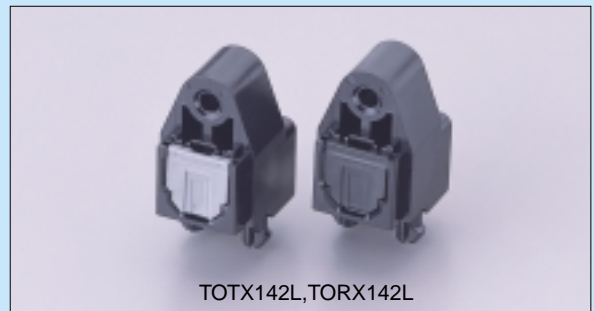

The information contained herein is subject to change without notice. 021023_D

The information contained herein is presented only as a guide for the applications of our products. No responsibility is assumed by TOSHIBA for any infringements of patents or other rights of the third parties which may result from its use. No license is granted by implication or otherwise under any patent or patent rights of TOSHIBA or others. 021023_C

TOSHIBA is continually working to improve the quality and reliability of its products. Nevertheless, semiconductor devices in general can malfunction or fail due to their inherent electrical sensitivity and vulnerability to physical stress. It is the responsibility of the buyer, when utilizing TOSHIBA products, to comply with the standards of safety in making a safe design for the entire system, and to avoid situations in which a malfunction or failure of such TOSHIBA products could cause loss of human life, bodily injury or damage to property. In developing your designs, please ensure that TOSHIBA products are used within specified operating ranges as set forth in the most recent TOSHIBA products specifications. Also, please keep in mind the precautions and conditions set forth in the "Handling Guide for Semiconductor Devices," or "TOSHIBA Semiconductor Reliability Handbook" etc. 021023_A

The Toshiba products listed in this document are intended for usage in general electronics applications (computer, personal equipment, office equipment, measuring equipment, industrial robotics, domestic appliances, etc.). These Toshiba products are neither intended nor warranted for usage in equipment that requires extraordinarily high quality and/or reliability or a malfunction or failure of which may cause loss of human life or bodily injury ("Unintended Usage"). Unintended Usage include atomic energy control instruments, airplane or spaceship instruments, transportation instruments, traffic signal instruments, combustion control instruments, medical instruments, all types of safety devices, etc. Unintended Usage of Toshiba products listed in this document shall be made at the customer's own risk. 021023_B

The products described in this document may include products subject to the foreign exchange and foreign trade laws. 021023_F
TOSHIBA products should not be embedded to the downstream products which are prohibited to be produced and sold, under any law and regulations. 030519_Q
GaAs(Gallium Arsenide) is used in some of the products. The dust or vapor is harmful to the human body. Do not break, cut, crush or dissolve chemically. 021023_J

Website: <http://www.semicon.toshiba.co.jp/eng>

TOSHIBA

TOSHIBA CORPORATION

Semiconductor Company

Website: <http://www.semicon.toshiba.co.jp/eng>

©2003 TOSHIBA CORPORATION

Printed in Japan

2003-7(0.5k)PC-O