

30 MICS/SMD RP

Micromodul™ connectors, pitch 1.27 mm

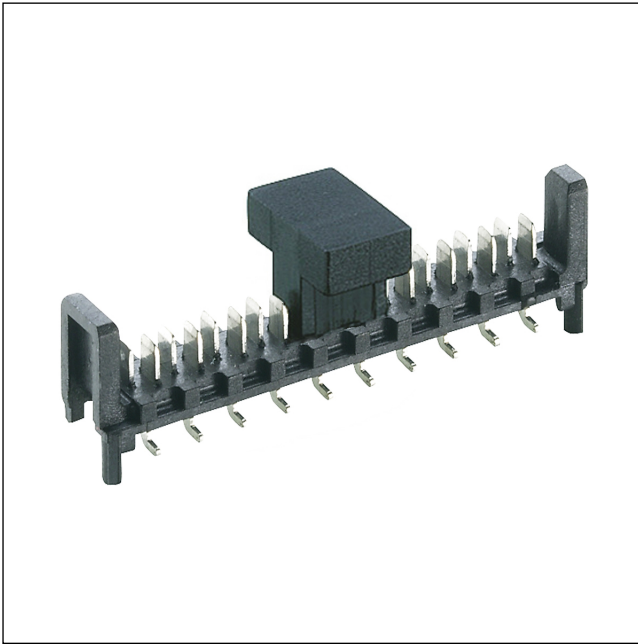

Micromodul™ tab header, upright, in surface mount technology (SMT), solder contacts dual row staggered, with press-fit spigots, on reel, with pick-and-place cap

Approvals:



30 MICS/SMD RP

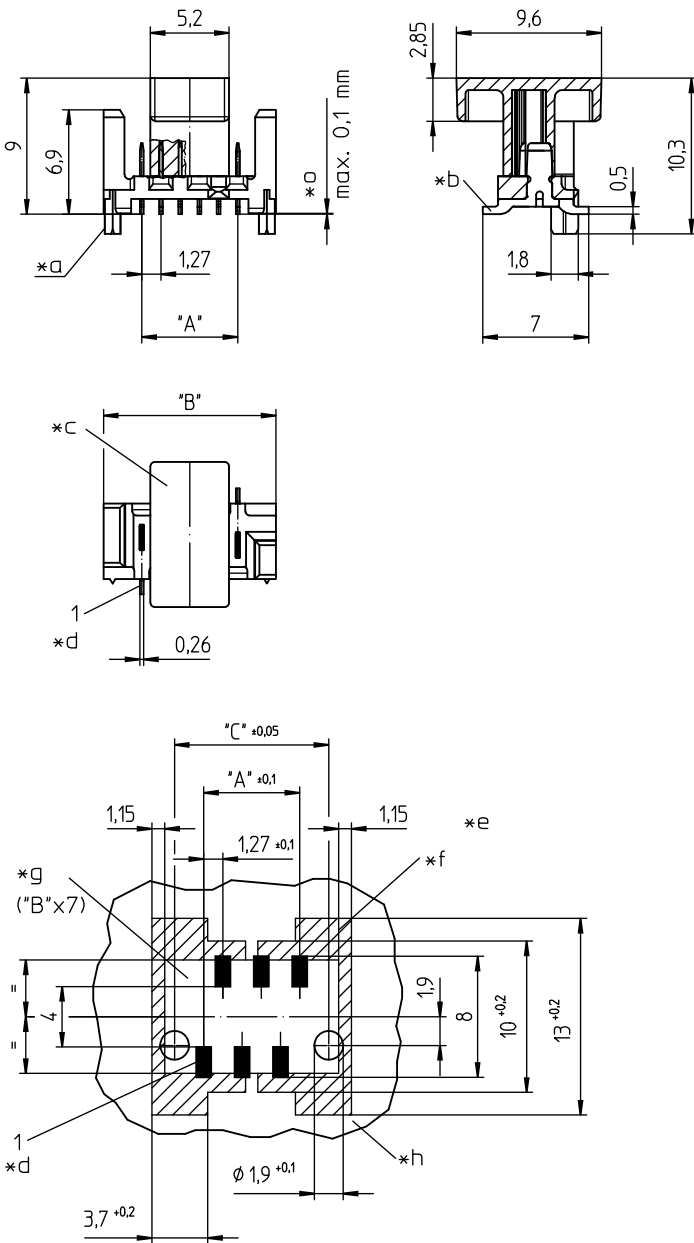

**Environmental conditions**

Temperature range -40 °C/+140 °C<sup>1</sup>  
<sup>1</sup> upper limit temperature (insulating body) RTI (electrical) of the UL Yellow Card

**Materials**

Insulating body PA GF, V-0 according to UL94  
 Contact tab CuZn, pre-nickel and tin-plated – MICS/SMD RP  
 CuZn, pre-nickel and gold-plated – MICS/SMD RP AU

**Mechanical data**

Expression force contact tab from insulating body ≥ 7 N/contact

**Electrical data (at T<sub>amb</sub> 20 °C)**

Rated current 1.2 A  
 Rated voltage 80 V AC  
 (250 V AC without consideration of creepage and clearance distances according to IEC 60664/DIN EN 60664)  
 Material group II (IEC)/I (UL) (CTI ≥ 450)  
 Creepage distance 0.97 mm  
 Clearance 0.97 mm  
 Insulation resistance > 1 GΩ

**Associated products**

Counterparts  
 ☞ MICA ☞ MICA VP3

30

MICS/SMD RP

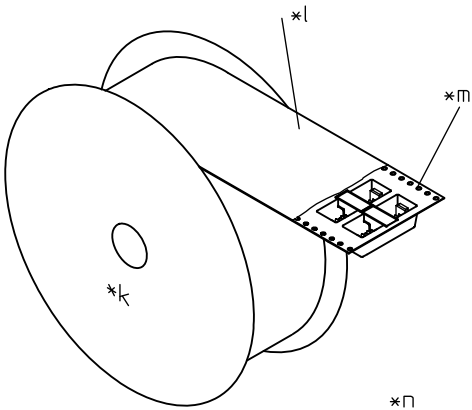
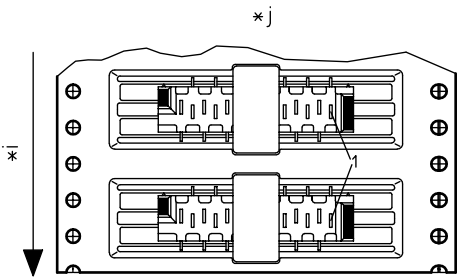

30 MICS/SMD RP

- 
- \*a press-fit spigot
  - \*b SMT solder area, contact bearing surface 0.3 x 1.2 mm
  - \*c pick-and-place top
  - \*d contact 1
  - \*e printed circuit board layout, components side view
  - \*f necessary space for use of pull-off tongs AZ30
  - \*g component area (B x 7)
  - \*h recommended thickness of circuit board 1.5 ±0.14 mm
  - \*i unreeling direction
  - \*j orientation of component in belt
  - \*k bolt dimension 12 mm
  - \*l protective strip
  - \*m blister belt
  - \*n core diameter 100 mm  
reel diameter 330 mm  
500 pieces per reel
  - \*o coplanarity

30 MICS/SMD RP

Designation	Pole Number	PU (Pieces)	MDQ (Pieces)	Dimensions		
				A (mm)	B (mm)	C (mm)
MICS/SMD 04 RP	4	3500	3500	3.81	8.86	7.66
MICS/SMD 06 RP	6	3500	3500	6.35	11.40	10.20
MICS/SMD 08 RP	8	3500	3500	8.89	13.94	12.74
MICS/SMD 10 RP	10	3500	3500	11.43	16.48	15.28
MICS/SMD 12 RP	12	3500	3500	13.97	19.02	17.82
MICS/SMD 14 RP	14	3500	3500	16.51	21.56	20.36
MICS/SMD 16 RP	16	3500	3500	19.05	24.10	22.90
MICS/SMD 18 RP	18	3500	3500	21.59	26.64	25.44
MICS/SMD 20 RP	20	3500	3500	24.13	29.18	27.98
MICS/SMD 26 RP	26	2400	2400	31.75	36.80	35.60
MICS/SMD 04 0,4 AU RP	4	3500	3500	3.81	8.86	7.66
MICS/SMD 06 0,4 AU RP	6	3500	3500	6.35	11.40	10.20
MICS/SMD 08 0,4 AU RP	8	3500	3500	8.89	13.94	12.74
MICS/SMD 10 0,4 AU RP	10	3500	3500	11.43	16.48	15.28
MICS/SMD 14 0,4 AU RP	14	3500	3500	16.51	21.56	20.36
MICS/SMD 16 0,4 AU RP	16	3500	3500	19.05	24.10	22.90
MICS/SMD 20 0,4 AU RP	20	3500	3500	24.13	29.18	27.98
MICS/SMD 04 0,8 AU RP	4	3500	3500	3.81	8.86	7.66
MICS/SMD 06 0,8 AU RP	6	3500	3500	6.35	11.40	10.20
MICS/SMD 08 0,8 AU RP	8	3500	3500	8.89	13.94	12.74
MICS/SMD 10 0,8 AU RP	10	3500	3500	11.43	16.48	15.28
MICS/SMD 12 0,8 AU RP	12	3500	3500	16.51	21.56	20.36
MICS/SMD 16 0,8 AU RP	16	3500	3500	19.05	24.10	22.90
MICS/SMD 20 0,8 AU RP	20	3500	3500	24.13	29.18	27.98

**Packaging:**  
on reel