

HD3SS6126 USB 3.0 and USB 2.0 Differential Switch 2:1/1:2 MUX/DEMUX

1 Features

- Ideal for USB Applications
 - Signal Switch for USB 3.0 (SuperSpeed USB and USB 2.0 HS/FS/LS)
- Three Bidirectional Differential Pair Channel MUX/DEMUX Switches Also Suitable for DisplayPort, PCIe Gen1/2/3, SATA 1.5/3/6G, SAS 1.5/3/6G and XAUI Applications
- Supports Data Rates up to 10 Gbps on High-Bandwidth Path (SS)
- V_{CC} Operating Range 3.3 V \pm 10%
- Wide –3-dB Differential BW of More Than 10 GHz on High-Bandwidth Path (SS)
- Uses a Unique Adaptation Method to Maintain a Constant Channel Impedance Over the Supported Common-Mode Voltage Range
- Excellent High-bandwidth Path Dynamic Characteristics (at 2.5 GHz)
 - Crosstalk = –35 dB
 - Isolation = –23 dB
 - Insertion Loss = –1.1 dB
 - Return Loss = –11 dB
- Small 3.5 mm x 9 mm, 42-Pin WQFN Package (RUA)
- Active Mode Power = 8 mW

2 Applications

- Desktop PCs
- Notebook PCs
- Tablets
- Docking Stations
- Telecommunications
- Televisions

3 Description

The HD3SS6126 device is a high-speed, passive switch that is designed for USB applications to route both SuperSpeed USB RX and TX and USB 2.0 DP and DM signals from a source to two destinations or vice versa. The device can also be used for DisplayPort, PCI-Express™, SATA, SAS, and XAUI applications. The HD3SS6126 device can be used in either sink-side or source-side applications.

Device Information⁽¹⁾

PART NUMBER	PACKAGE	BODY SIZE (NOM)
HD3SS6126	WQFN (42)	9.00 mm x 3.50 mm

(1) For all available packages, see the orderable addendum at the end of the data sheet.

Typical Application Diagram

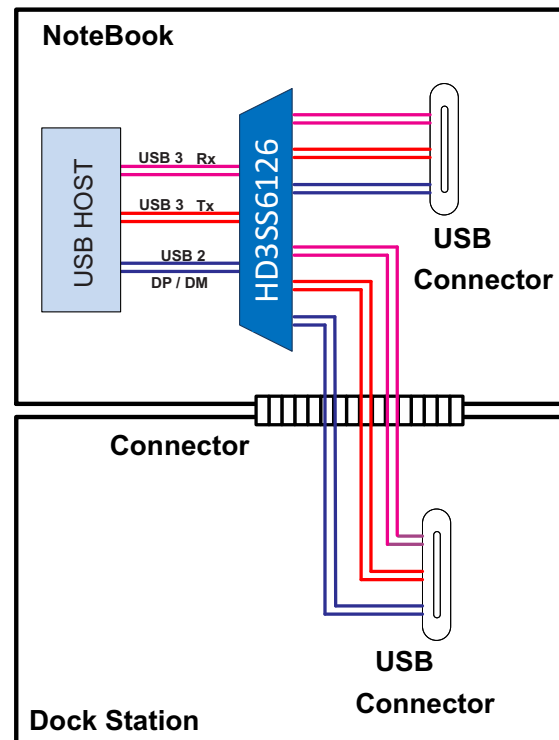

An IMPORTANT NOTICE at the end of this data sheet addresses availability, warranty, changes, use in safety-critical applications, intellectual property matters and other important disclaimers. PRODUCTION DATA.

Table of Contents

1 Features	1	7.2 Functional Block Diagram	11
2 Applications	1	7.3 Feature Description.....	11
3 Description	1	7.4 Device Functional Modes.....	12
4 Revision History	2	8 Application and Implementation	13
5 Pin Configuration and Functions	3	8.1 Application Information.....	13
6 Specifications	5	8.2 Typical Application	13
6.1 Absolute Maximum Ratings	5	9 Power Supply Recommendations	15
6.2 ESD Ratings.....	5	10 Layout	15
6.3 Recommended Operating Conditions.....	5	10.1 Layout Guidelines	15
6.4 Thermal Information	6	10.2 Layout Examples.....	15
6.5 Electrical Characteristics – Device Parameters.....	6	11 Device and Documentation Support	17
6.6 Electrical Characteristics – Signal Switch Parameters.....	7	11.1 Community Resources.....	17
6.7 Switching Characteristics	8	11.2 Trademarks	17
6.8 Typical Characteristics	10	11.3 Electrostatic Discharge Caution.....	17
7 Detailed Description	10	11.4 Glossary	17
7.1 Overview	10	12 Mechanical, Packaging, and Orderable Information	17

4 Revision History

NOTE: Page numbers for previous revisions may differ from page numbers in the current version.

Changes from Original (November 2013) to Revision A	Page
<ul style="list-style-type: none"> Added <i>Pin Configuration and Functions</i> section, <i>ESD Ratings</i> table, <i>Typical Characteristics</i> section, <i>Feature Description</i> section, <i>Device Functional Modes</i>, <i>Application and Implementation</i> section, <i>Power Supply Recommendations</i> section, <i>Layout</i> section, <i>Device and Documentation Support</i> section, and <i>Mechanical, Packaging, and Orderable Information</i> section 	1

5 Pin Configuration and Functions

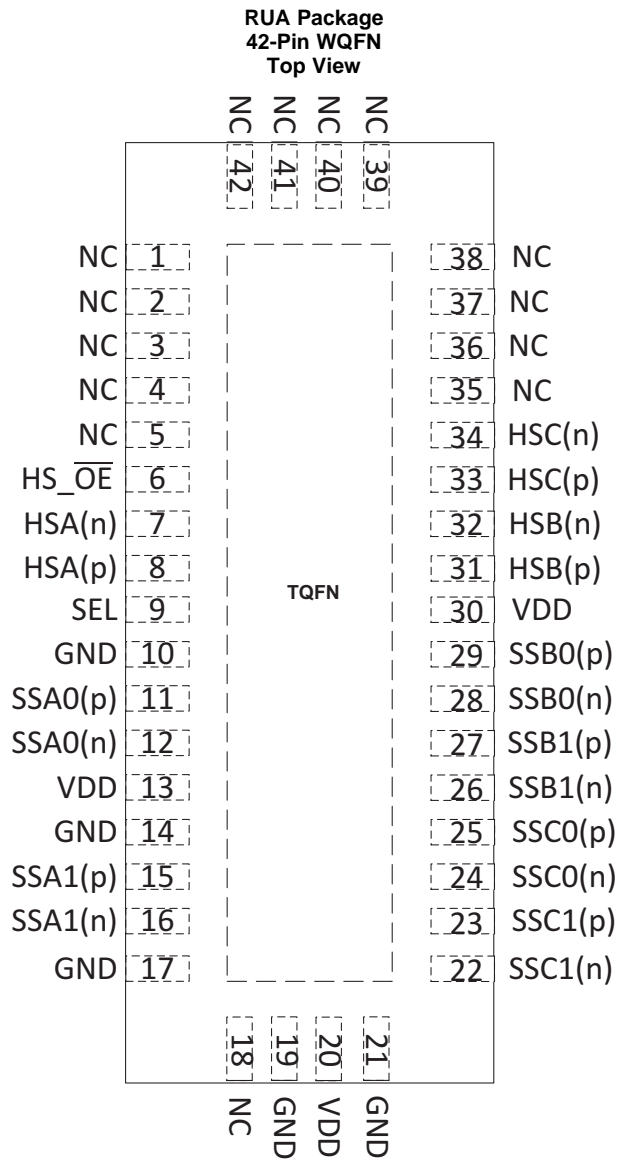

Pin Functions

PIN		I/O	DESCRIPTION
NAME	NO.		
GND	10, 14, 17, 19, 21	Supply	Ground
HSA(p)	8	I/O	Port A USB 2.0 positive signal
HSA(n)	7		Port A USB 2.0 negative signal
HSB(p)	31	I/O	Port B USB 2.0 positive signal
HSB(n)	32		Port B USB 2.0 negative signal
HSC(p)	33	I/O	Port C USB 2.0 positive signal
HSC(n)	34		Port C USB 2.0 negative signal
HS_ $\overline{\text{OE}}$	6	I (Control)	Output Enable H = Power Down L = Normal Operation
NC	1, 2, 3, 4, 5, 18, 35, 36, 37, 38, 39, 40, 41, 42	—	Electrically No Connection
SEL	9	I (Control)	USB 3.0/2.0 Port Selection Control Pins
SSA0(p)	11	I/O	Port A, Channel 0, USB 3.0 Positive Signal
SSA0(n)	12		Port A, Channel 0, USB 3.0 Negative Signal
SSA1(p)	15	I/O	Port A, Channel 1, USB 3.0 Positive Signal
SSA1(n)	16		Port A, Channel 1, USB 3.0 Negative Signal
SSB0(p)	29	I/O	Port B, Channel 0, USB 3.0 Positive Signal
SSB0(n)	28		Port B, Channel 0, USB 3.0 Negative Signal
SSB1(p)	27	I/O	Port B, Channel 1, USB 3.0 Positive Signal
SSB1(n)	26		Port B, Channel 1, USB 3.0 Negative Signal
SSC0(p)	25	I/O	Port C, Channel 0, USB 3.0 Positive Signal
SSC0(n)	24		Port C, Channel 0, USB 3.0 Negative Signal
SSC1(p)	23	I/O	Port C, Channel 1, USB 3.0 Positive Signal
SSC1(n)	22		Port C, Channel 1, USB 3.0 Negative Signal
VDD	13, 20, 30	Supply	3.3-V power supply voltage

6 Specifications

6.1 Absolute Maximum Ratings

over operating free-air temperature range (unless otherwise noted)⁽¹⁾

		MIN	MAX	UNIT
Supply Voltage, V_{DD} ⁽²⁾		-0.3	4	V
Voltage	Differential I/O, High-bandwidth signal path: SSA0/1(p/n), SSB0/1(p/n), SSC0/1(p/n)	-0.5	4	V
	Differential I/O, Low-bandwidth signal path: HSAp(n), HSB(p/n), HSC(p/n)	-0.5	7	
	Control pin and single ended I/O	-0.3	$V_{DD} + 0.3$	
Continuous power dissipation		See Thermal Information		
Storage temperature, T_{stg}		-65	150	°C

- (1) Stresses beyond those listed under *Absolute Maximum Ratings* may cause permanent damage to the device. These are stress ratings only and functional operation of the device at these or any conditions beyond those indicated under *Recommended Operating Conditions* is not implied. Exposure to absolute-maximum-rated conditions for extended periods may affect device reliability.
- (2) All voltage values, except differential voltages, are with respect to network ground terminal.

6.2 ESD Ratings

		VALUE	UNIT
$V_{(ESD)}$ Electrostatic discharge	Human body model (HBM), per ANSI/ESDA/JEDEC JS-001 ⁽¹⁾	±2000	V
	Charged device model (CDM), per JEDEC specification JESD22-C101 ⁽²⁾	±500	

- (1) JEDEC document JEP155 states that 500-V HBM allows safe manufacturing with a standard ESD control process.
- (2) JEDEC document JEP157 states that 250-V CDM allows safe manufacturing with a standard ESD control process.

6.3 Recommended Operating Conditions

typical values for all parameters are at $V_{CC} = 3.3$ V and $T_A = 25^\circ\text{C}$; all temperature limits are specified by design

			MIN	NOM	MAX	UNIT
V_{DD}	Supply voltage		3.0	3.3	3.6	V
V_{IH}	Input high voltage	Control Pins	2.0		V_{DD}	V
V_{IL}	Input low voltage	Control Pins	-0.1		0.8	V
V_{I/O_Diff}	Differential voltage	Switch I/O differential voltage for High-bandwidth signal path only: SSA0/1(p/n), SSB0/1(p/n), SSC0/1(p/n)	0		1.8	V_{p-p}
V_{I/O_CM}	Common voltage	Switch I/O common mode voltage for High-bandwidth signal path only: SSA0/1(p/n), SSB0/1(p/n), SSC0/1(p/n)	0		2.0	V
T_A	Operating free-air temperature		0		70	°C

6.4 Thermal Information

THERMAL METRIC		HD3SS6126	
		RUA (WQFN)	
		42 PINS	
Symbol	Description	Value	Unit
$R_{\theta JA}$	Junction-to-ambient thermal resistance	53.8	°C/W
$R_{\theta JC(top)}$	Junction-to-case (top) thermal resistance	38.2	°C/W
$R_{\theta JB}$	Junction-to-board thermal resistance	27.4	°C/W
Ψ_{JT}	Junction-to-top characterization parameter ⁽¹⁾	5.6	°C/W
Ψ_{JB}	Junction-to-board characterization parameter ⁽¹⁾	27.3	°C/W

(1) For more information about traditional and new thermal metrics, see *Semiconductor and IC Package Thermal Metrics* application report, [SPRA953](#). Test conditions for Ψ_{JB} and Ψ_{JT} are clarified in the application report..

6.5 Electrical Characteristics – Device Parameters

over recommended operating conditions (unless otherwise noted)

PARAMETER		TEST CONDITIONS	MIN	TYP	MAX	UNIT
I_{CC}	Supply current	$V_{DD} = 3.6\text{ V}$, $SEL = V_{DD}/GND$; $\overline{OE} = GND$; Outputs Floating		2.4	3	mA
SEL						
I_{IH}	Input high current	$V_{DD} = 3.6\text{ V}$, $V_{IN} = V_{DD}$			95	μA
I_{IL}	Input high current	$V_{DD} = 3.6\text{ V}$, $V_{IN} = GND$			1	μA
HS\overline{OE}						
I_{IH}	Input high current	$V_{DD} = 3.6\text{ V}$, $V_{IN} = V_{DD}$			1	μA
I_{IL}	Input high current	$V_{DD} = 3.6\text{ V}$, $V_{IN} = GND$			1	μA
SSA0/1, SSB0/1, SSC0/1						
I_{LK}	High-impedance leakage current	$V_{DD} = 3.6\text{ V}$, $V_{IN} = 2\text{ V}$, $V_{OUT} = 2\text{ V}$, (I_{LK} on open outputs Port B and C)			130	μA
		$V_{DD} = 3.6\text{ V}$, $V_{IN} = 2\text{ V}$, $V_{OUT} = 2\text{ V}$, (I_{LK} on open outputs Port A)			4	
HSA, HSB, HSC						
I_{LK}	High-impedance leakage current	$V_{DD} = 3.6\text{ V}$, $V_{IN} = 0\text{ V}$, $V_{OUT} = 0\text{ V to } 4\text{ V}$, $HS_OE_IN = GND$			1	μA

6.6 Electrical Characteristics – Signal Switch Parameters

 under recommended operating conditions; $R_L, R_{SC} = 50 \Omega$, $C_L = 10 \text{ pF}$ (unless otherwise noted)

PARAMETER		TEST CONDITIONS	MIN	TYP	MAX	UNIT
SSA0/1(p/n), SSB0/1(p/n), SSC0/1(p/n) Signal Path						
C_{ON}	Outputs ON capacitance	$V_{IN} = 0 \text{ V}$, outputs open, switch ON		1.5		pF
C_{OFF}	Outputs OFF capacitance	$V_{IN} = 0 \text{ V}$, outputs open, switch OFF		1		pF
R_{ON}	Output ON resistance	$V_{DD} = 3.3 \text{ V}$, $V_{CM} = 0 \text{ V} - 2 \text{ V}$, $I_O = -8 \text{ mA}$		5	8	Ω
ΔR_{ON}	ON resistance match between pairs of the same channel	$V_{DD} = 3.3 \text{ V}$; $0 \text{ V} \leq V_{IN} \leq 2 \text{ V}$; $I_O = -8 \text{ mA}$			0.7	Ω
R_{FLAT_ON}	ON resistance flatness ($R_{ON(MAX)} - R_{ON(MIN)}$)	$V_{DD} = 3.3 \text{ V}$; $-0 \text{ V} \leq V_{IN} \leq 2 \text{ V}$			1.15	Ω
R_L	Differential return loss ($V_{CM} = 0 \text{ V}$)	$f = 0.3 \text{ MHz}$		-25		dB
		$f = 2.5 \text{ GHz}$		-11		
		$f = 4 \text{ GHz}$		-11		
X_{TALK}	Differential crosstalk ($V_{CM} = 0 \text{ V}$)	$f = 0.3 \text{ MHz}$		-85		dB
		$f = 2.5 \text{ GHz}$		-35		
		$f = 4 \text{ GHz}$		-33		
O_{IRR}	Differential off-isolation ($V_{CM} = 0 \text{ V}$)	$f = 0.3 \text{ MHz}$		-85		dB
		$f = 2.5 \text{ GHz}$		-23		
		$f = 4 \text{ GHz}$		-21		
I_L	Differential insertion loss ($V_{CM} = 0 \text{ V}$)	$f = 0.3 \text{ MHz}$		-0.43		dB
		$f = 2.5 \text{ GHz}$		-1.1		
		$f = 4 \text{ GHz}$		-1.3		
BW	Bandwidth	At -3 dB		10		GHz
HSA(p/n), HSB(p/n), HSC(p/n) SIGNAL PATH						
C_{ON}	Outputs ON capacitance	$V_{IN} = 0 \text{ V}$, Outputs Open, Switch ON		6	7.5	pF
C_{OFF}	Outputs OFF capacitance	$V_{IN} = 0 \text{ V}$, Outputs Open, Switch OFF		3.5	6	pF
R_{ON}	Output ON resistance	$V_{DD} = 3 \text{ V}$, $V_{IN} = 0 \text{ V}$, $I_O = 30 \text{ mA}$		3	6	Ω
		$V_{DD} = 3 \text{ V}$, $V_{IN} = 2.4 \text{ V}$, $I_O = 30 \text{ mA}$		3.4	6	
ΔR_{ON}	ON resistance match between pairs of the same channel	$V_{DD} = 3 \text{ V}$; $V_{IN} = 0 \text{ V}$; $I_O = 30 \text{ mA}$		0.2		Ω
		$V_{DD} = 3 \text{ V}$; $V_{IN} = 1.7 \text{ V}$; $I_O = -15 \text{ mA}$		0.2		
R_{FLAT_ON}	ON resistance flatness ($R_{ON(MAX)} - R_{ON(MIN)}$)	$V_{DD} = 3 \text{ V}$; $V_{IN} = 0 \text{ V}$; $I_O = 30 \text{ mA}$		1		Ω
		$V_{DD} = 3 \text{ V}$; $V_{IN} = 1.7 \text{ V}$; $I_O = -15 \text{ mA}$		1		
X_{TALK}	Differential crosstalk ($V_{CM} = 0 \text{ V}$)	$R_L = 50 \Omega$, $f = 250 \text{ MHz}$		-40		dB
O_{IRR}	Differential off-isolation ($V_{CM} = 0 \text{ V}$)	$R_L = 50 \Omega$, $f = 250 \text{ MHz}$		-41		dB
BW	Bandwidth	$R_L = 50 \Omega$		0.9		GHz

6.7 Switching Characteristics

over operating free-air temperature range (unless otherwise noted)

PARAMETER	TEST CONDITIONS	MIN	TYP	MAX	UNIT	
SSA0/1(p/n), SSB0/1(p/n), SSC0/1(p/n) Signal Path						
t_{on}	SEL-to-Switch t_{on}	R_{SC} and $R_L = 50 \Omega$, See Figure 1		70	250	ns
t_{off}	SEL-to-Switch t_{off}	R_{SC} and $R_L = 50 \Omega$, See Figure 1		70	250	ns
t_{PD}	Switch propagation delay	R_{SC} and $R_L = 50 \Omega$, See Figure 3			85	ps
$t_{SK(O)}$	Interpair output skew (CH-CH)	R_{SC} and $R_L = 50 \Omega$, See Figure 3			20	ps
$t_{SK(b-b)}$	Intrapair Output Skew (bit-bit)	R_{SC} and $R_L = 50 \Omega$, See Figure 3			8	ps
HSA(p/n), HSB(p/n), HSC(p/n) SIGNAL PATH						
t_{ON}	SEL to Switch t_{ON}	See Figure 2		30	ns	
	HS_ \overline{OE} to Switch t_{ON}	See Figure 2		17		
t_{OFF}	SEL to Switch t_{OFF}	See Figure 2		12	ns	
	HS_ \overline{OE} to Switch t_{OFF}	See Figure 2		10		
$t_{PD}^{(1)}$	Switch propagation delay	See Figure 3		250	ps	
$t_{SK(O)}^{(1)}$	Interpair output skew (CH-CH)			100	200	ps
$t_{SK(P)}^{(1)}$	Intrapair Output Skew (bit-bit)			100	200	ps

(1) Specified by design

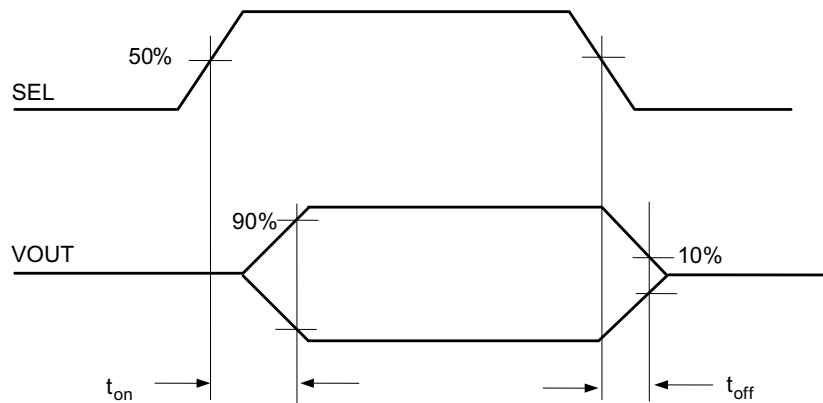
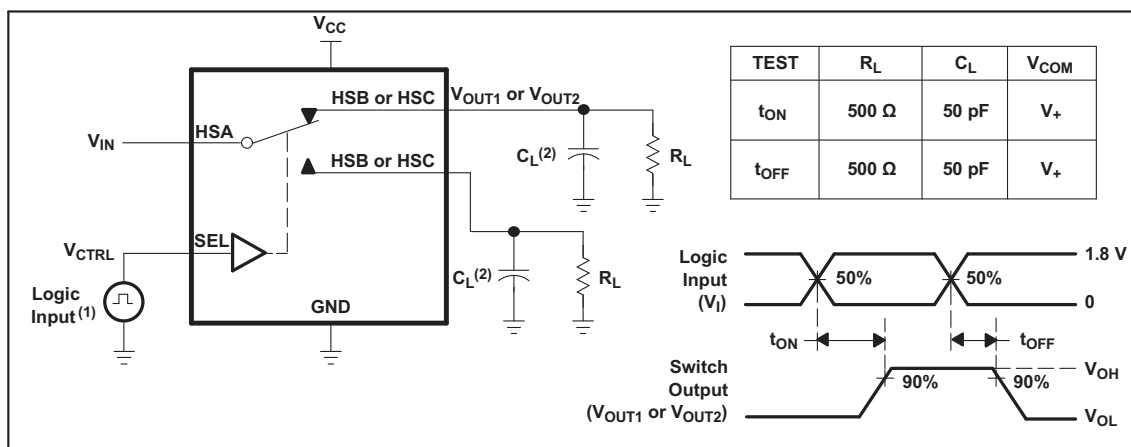
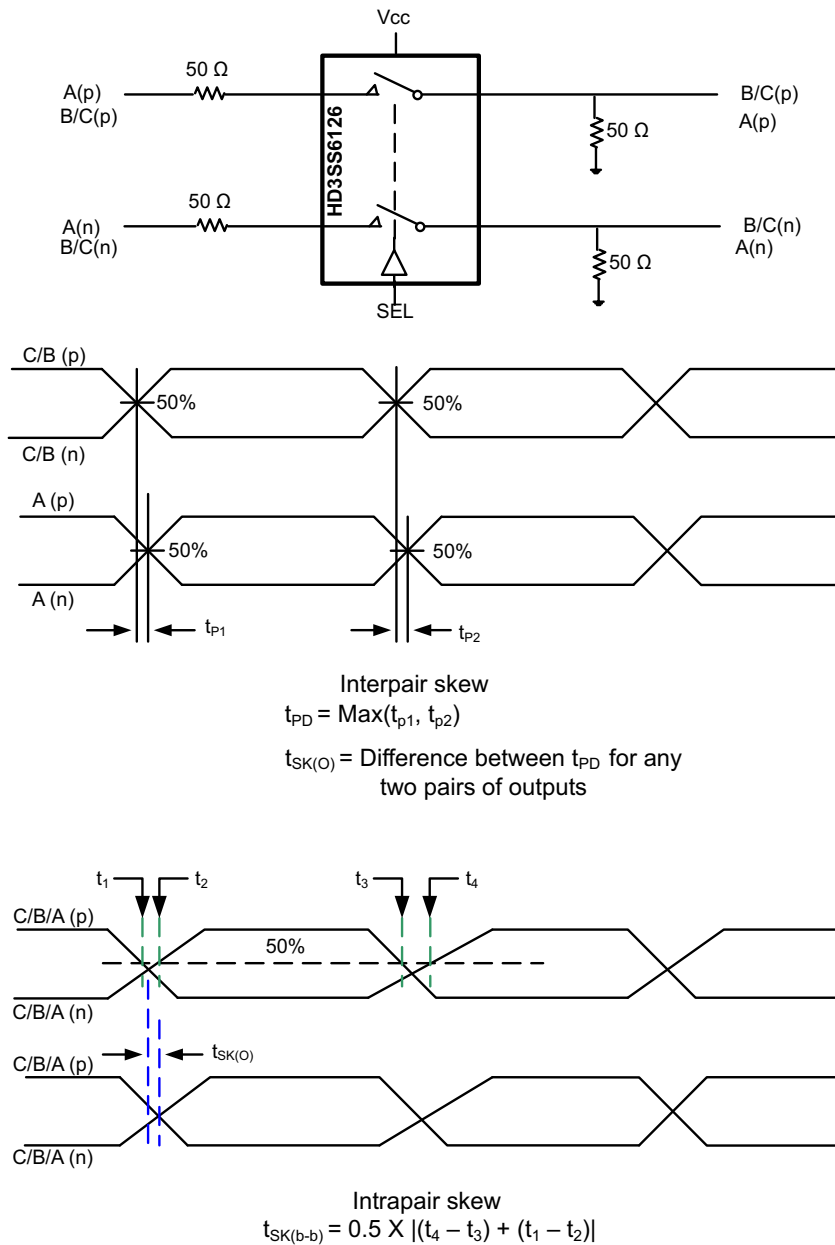

Figure 1. Select to Switch t_{ON} and t_{OFF}



(1) All input pulses are supplied by generators have the following characteristics: PRR \leq 10 MHz, $Z_O = 50 \Omega$, $t_r < 5$ ns, $t_f < 5$ ns.
 (2) C_L includes probe and jig capacitance.

Figure 2. Turnon (t_{ON}) and Turnoff Time (t_{OFF})



NOTES:

1. Measurements based on an ideal input with zero intrapair skew on the input, i.e. the input at A to B/C or the input at B/C to A
2. Interpair skew is measured from lane to lane on the same channel, e.g. C0 to C1
3. Intrapair skew is defined as the relative difference from the p and n signals of a single lane

Figure 3. Propagation Delay and Skew

6.8 Typical Characteristics

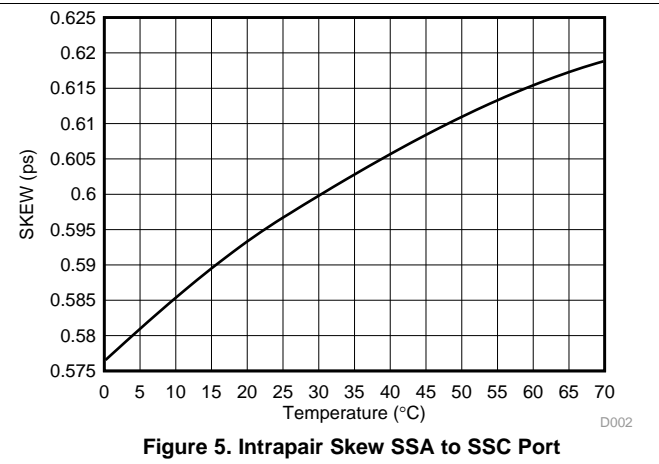
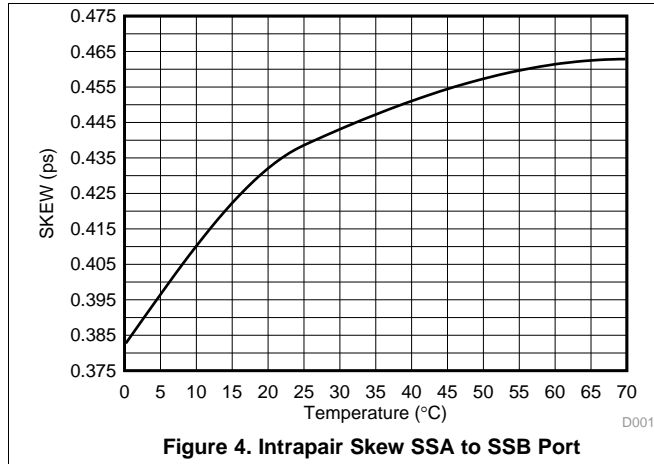

7 Detailed Description

7.1 Overview

The HD3SS6126 is a USB 3.0 and USB 2.0 differential switch, it is designed to support data rates up to 10 Gbps on high-bandwidth paths (SS), it is also suitable for DisplayPort, PCIe Gen1/2/3, SATA 1.5/3/6G, SAS 1.5/3/6G and XAUI applications. The device uses a unique adaptation method to maintain a constant channel impedance over the supported common-mode voltage range, resulting in an excellent high-bandwidth path dynamic characteristics (at 2.5 GHz; Crosstalk = -35 dB, Isolation = -23 dB, Insertion Loss = -1.1 dB, Return Loss = -11 dB).

7.2 Functional Block Diagram

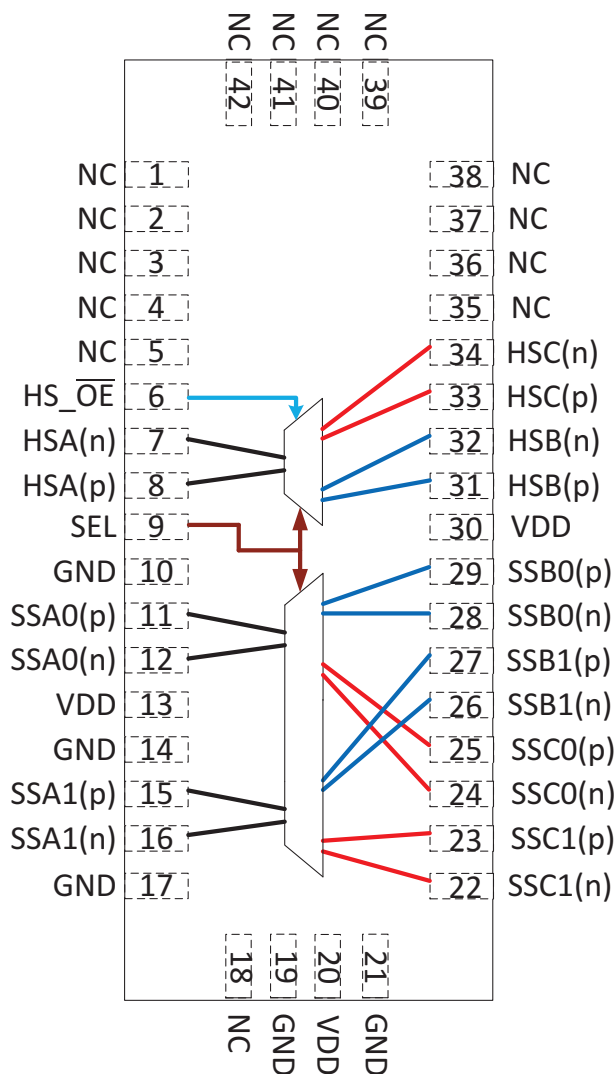

7.3 Feature Description

The HD3SS6126 can be powered by VBUS from the USB Host, and is capable of selecting USB2 independently from USB3. Although the main application of the HD3SS6126 is USB3.0/2.0, the device also supports common interfaces such as PCIe Gen1 and Gen2, DP and SATA/SAS applications. The device is able to support these additional interfaces because of its support of data rates up to 5.4 Gbps and common-mode voltages from 0 V to 2 V with a maximum signal swing of 1.8 V. All of these applications use an 8b or 10b coding technique to achieve DC balance and facilitate terminal equipment.

NOTE

The device may need AC capacitors and additional bias voltage to support the PCIe Gen1 and Gen2 interfaces.

7.4 Device Functional Modes

Table 1. Truth Table USB 3.0 SuperSpeed USB

SEL	USB 3.0 PORT SELECTION		
	SSA0/1	SSB0/1	SSC0/1
0	To/From SSB0/1	To/From SSA0/1	Off
1	To/From SSC0/1	Off	To/From SSA0/1

Table 2. Truth Table USB 2.0 High-Speed, Full-Speed, Low-Speed Path

HS_ $\overline{\text{OE}}$	SEL	USB 2.0 Port Selection		
		HSA	HSB	HSC
0	0	To/From HSB	To/From HSA	Off
0	1	To/From HSC	Off	To/From HSA
1	X	Off	Off	Off

8 Application and Implementation

NOTE

Information in the following applications sections is not part of the TI component specification, and TI does not warrant its accuracy or completeness. TI's customers are responsible for determining suitability of components for their purposes. Customers should validate and test their design implementation to confirm system functionality.

8.1 Application Information

A typical application for the HD3SS6126 is a USB 3.0 KVM switch, where one of two USB hosts system can be selected for an USB device. These guidelines are also suitable for PCIe(Gen1,Gen2), SATA, XAUI and DP, since the HD3SS6126 device is fully compatible with these protocols.

8.2 Typical Application

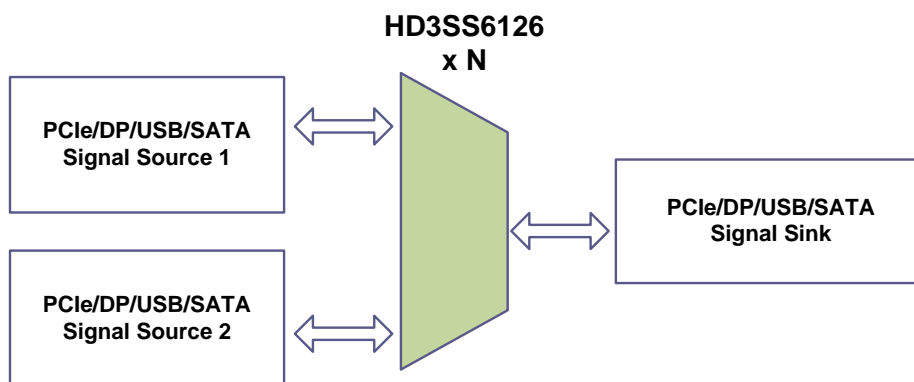

Figure 6. Two Signal Sources to One Destination

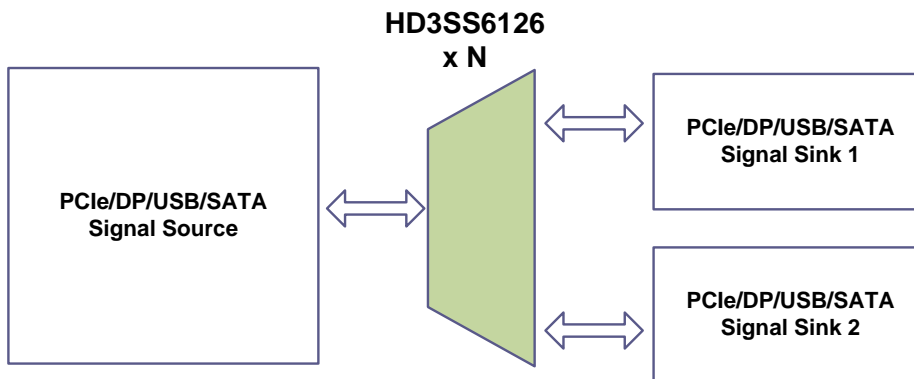

Figure 7. One Signal Sources to Two Destination

Typical Application (continued)

8.2.1 Design Requirements

Power supply requirements:

- V_{DD} from 3 V to 3.6 V

Control pins requirements

- V_{IH} from 2 V to V_{DD}
- V_{IL} from -0.1 V to 0.8 V

Differential pairs requirements:

- V_{I/O_Diff} from 0 V to 1.8 Vp-p
- V_{I/O_CM} from 0 V to 2 V

T_A Operating free-air temperature from 0°C to 70°C

8.2.2 Detailed Design Procedure

8.2.2.1 Power Supply

The first step is to design the power supply and determine the V_{CC} stability and minimum current required (see [Power Supply Recommendations](#)).

8.2.2.2 Differential Pairs

All of the interfaces the HD3SS6126 device supports require AC coupling between the transmitter and receiver. TI recommends using 0402-sized capacitors to provide AC coupling, but 0603-sized capacitors are also acceptable. Both 0805-sized capacitors and C-packs should be avoided. Best practice is to place AC-coupling capacitors symmetrically. A capacitor value of 0.1uF is best and the value should be matched for the +/-signal pair. The placement should be along the TX pairs on the system board, which are usually routed on the top layer of the board.

All differential pairs must have a matched impedance according to the implemented protocol: 100-Ω differential ($\pm 10\%$) for PCIe and 90-Ω differential ($\pm 15\%$) for USB 2.0 and USB 3.0.

The control logic can be implemented by use of an external control processor or by using a simple selector switch. TI recommends using 5-kΩ pullup and pulldown resistors on the control signals, if they are included. The control logic must not violate the input voltage parameters outlined in the [Recommended Operating Conditions](#) table.

8.2.3 Application Curves

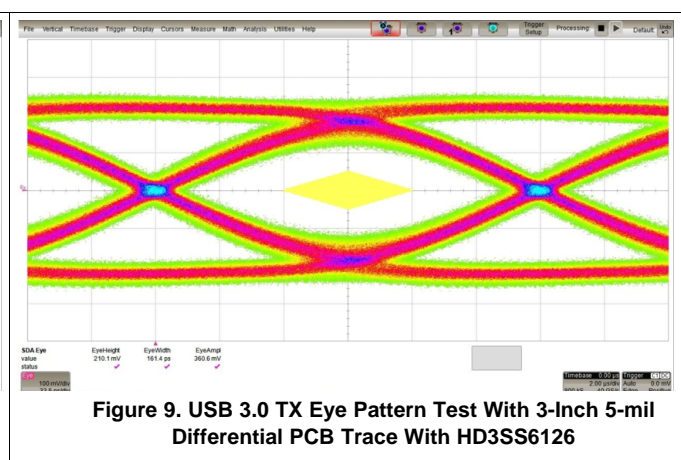
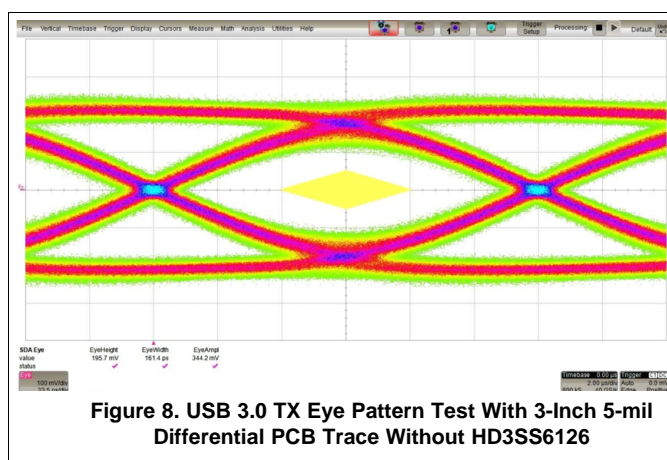

9 Power Supply Recommendations

The power supply must provide a constant voltage with a 10% maximum variation of the nominal value, and has to be able to provide at least 3 mA for the HD3SS6126 only (based on the maximum power consumption). It is also possible to provide the power supply from VBUS from the Host, just by including a voltage regulator powered through VBUS. Each V_{CC} pin must have a 0.1- μ F bypass capacitor placed as closely as possible. TI recommends including two extra capacitors in parallel, which should be also placed as closely as possible to the V_{CC} pin. The suggested values for these extra capacitors are 1 μ F and 0.01 μ F.

10 Layout

10.1 Layout Guidelines

Generally, impedance match becomes critical in such high-speed signal applications to avoid reflection. Each differential-signal pair must have a differential impedance of about $90 \Omega \pm 15\%$ (for PCIe or DP, $100 \Omega \pm 10\%$) with single-end signal impedance about 50Ω to ground. Usually, Microstrip is used to accomplish impedance match. Four layers are recommended for a low-EMI PCB design. shows physical geometries of differential traces to form Microstrip. In order to better maintain signal integrity, reference the following:

1. Route high-speed differential signals on the top layer with a solid ground layer under them to accomplish controlled impedance, while avoiding vias and stubs which may cause impedance discontinuities. If vias must be used, make sure the space of the vias is as minimal as possible.
2. Be sure both the length of differential traces and the length of differential signal pairs are matched in order to reduce intrapair skew and interpair skew separately which also does good to low EMI. TI recommends keeping the space of the traces of the differential signal the same across the entire length of the trace to keep impedance match and reduce EMI.
3. Route low-speed, but fast-edged control signals on the bottom layer to minimize the crosstalk of the high-speed signal.
4. For other adjacent signal traces on the same layer, make distance $L \geq 3 S$ to facilitate impedance match.
5. TI recommends using 45° bends instead of 90° bends in order to maintain signal integrity and low EMI.

10.2 Layout Examples

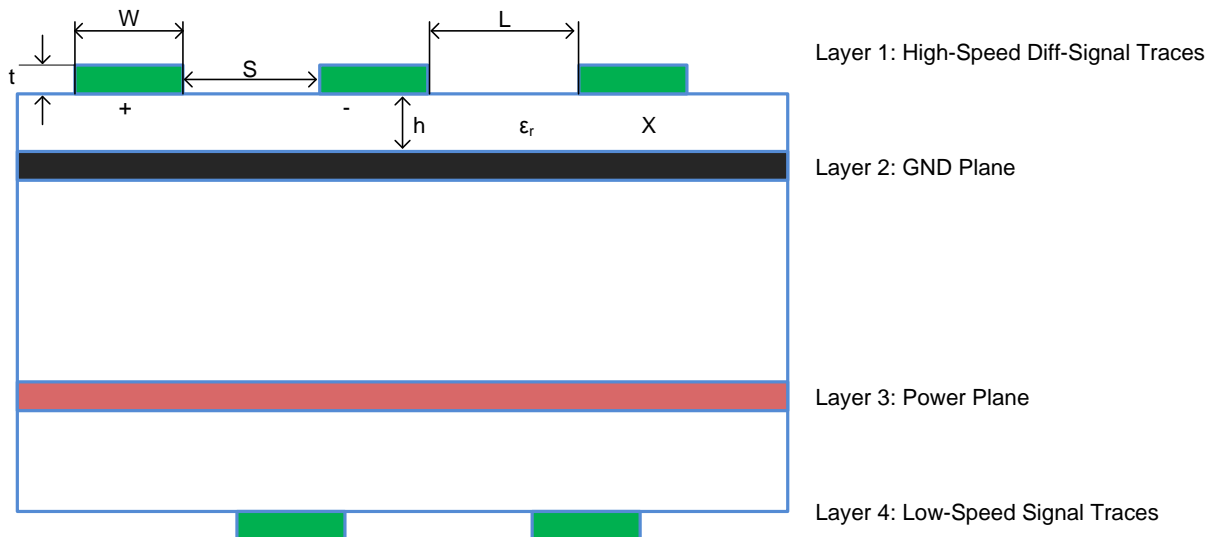

Figure 10. PCB Layers Example

Layout Examples (continued)

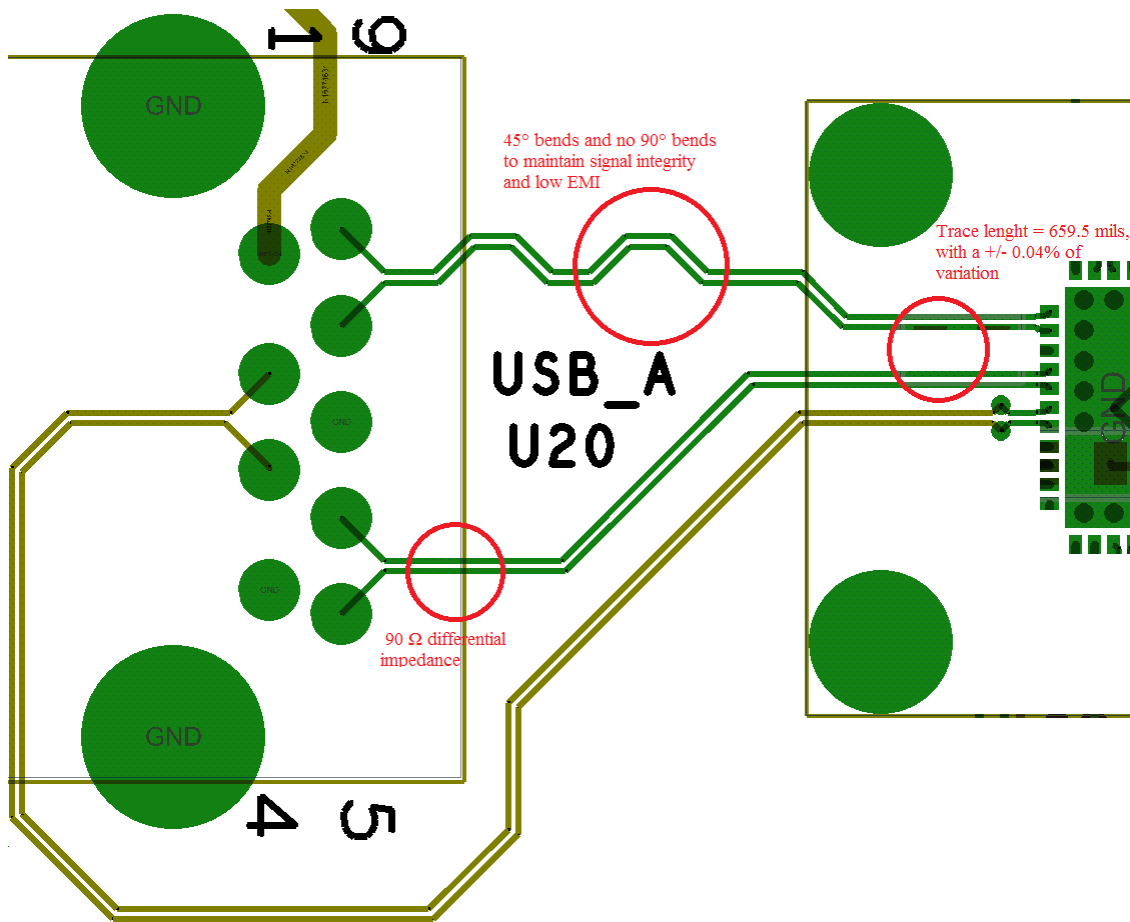

Figure 11. USB Signals Routing Example

11 Device and Documentation Support

11.1 Community Resources

The following links connect to TI community resources. Linked contents are provided "AS IS" by the respective contributors. They do not constitute TI specifications and do not necessarily reflect TI's views; see TI's [Terms of Use](#).

TI E2E™ Online Community *TI's Engineer-to-Engineer (E2E) Community*. Created to foster collaboration among engineers. At e2e.ti.com, you can ask questions, share knowledge, explore ideas and help solve problems with fellow engineers.

Design Support *TI's Design Support* Quickly find helpful E2E forums along with design support tools and contact information for technical support.

11.2 Trademarks

E2E is a trademark of Texas Instruments.

PCI-Express is a trademark of PCI-SIG.

All other trademarks are the property of their respective owners.

11.3 Electrostatic Discharge Caution



These devices have limited built-in ESD protection. The leads should be shorted together or the device placed in conductive foam during storage or handling to prevent electrostatic damage to the MOS gates.

11.4 Glossary

[SLYZ022](#) — *TI Glossary*.

This glossary lists and explains terms, acronyms, and definitions.

12 Mechanical, Packaging, and Orderable Information

The following pages include mechanical, packaging, and orderable information. This information is the most current data available for the designated devices. This data is subject to change without notice and revision of this document. For browser-based versions of this data sheet, refer to the left-hand navigation.

PACKAGING INFORMATION

Orderable Device	Status (1)	Package Type	Package Drawing	Pins	Package Qty	Eco Plan (2)	Lead finish/ Ball material (6)	MSL Peak Temp (3)	Op Temp (°C)	Device Marking (4/5)	Samples
HD3SS6126RUAR	ACTIVE	WQFN	RUA	42	3000	RoHS & Green	NIPDAU	Level-3-260C-168 HR	0 to 70	HD3SS6126	Samples

(1) The marketing status values are defined as follows:

ACTIVE: Product device recommended for new designs.

LIFEBUY: TI has announced that the device will be discontinued, and a lifetime-buy period is in effect.

NRND: Not recommended for new designs. Device is in production to support existing customers, but TI does not recommend using this part in a new design.

PREVIEW: Device has been announced but is not in production. Samples may or may not be available.

OBSOLETE: TI has discontinued the production of the device.

(2) **RoHS:** TI defines "RoHS" to mean semiconductor products that are compliant with the current EU RoHS requirements for all 10 RoHS substances, including the requirement that RoHS substance do not exceed 0.1% by weight in homogeneous materials. Where designed to be soldered at high temperatures, "RoHS" products are suitable for use in specified lead-free processes. TI may reference these types of products as "Pb-Free".

RoHS Exempt: TI defines "RoHS Exempt" to mean products that contain lead but are compliant with EU RoHS pursuant to a specific EU RoHS exemption.

Green: TI defines "Green" to mean the content of Chlorine (Cl) and Bromine (Br) based flame retardants meet JS709B low halogen requirements of <=1000ppm threshold. Antimony trioxide based flame retardants must also meet the <=1000ppm threshold requirement.

(3) MSL, Peak Temp. - The Moisture Sensitivity Level rating according to the JEDEC industry standard classifications, and peak solder temperature.

(4) There may be additional marking, which relates to the logo, the lot trace code information, or the environmental category on the device.

(5) Multiple Device Markings will be inside parentheses. Only one Device Marking contained in parentheses and separated by a "-" will appear on a device. If a line is indented then it is a continuation of the previous line and the two combined represent the entire Device Marking for that device.

(6) Lead finish/Ball material - Orderable Devices may have multiple material finish options. Finish options are separated by a vertical ruled line. Lead finish/Ball material values may wrap to two lines if the finish value exceeds the maximum column width.

Important Information and Disclaimer: The information provided on this page represents TI's knowledge and belief as of the date that it is provided. TI bases its knowledge and belief on information provided by third parties, and makes no representation or warranty as to the accuracy of such information. Efforts are underway to better integrate information from third parties. TI has taken and continues to take reasonable steps to provide representative and accurate information but may not have conducted destructive testing or chemical analysis on incoming materials and chemicals. TI and TI suppliers consider certain information to be proprietary, and thus CAS numbers and other limited information may not be available for release.

In no event shall TI's liability arising out of such information exceed the total purchase price of the TI part(s) at issue in this document sold by TI to Customer on an annual basis.

TAPE AND REEL INFORMATION



QUADRANT ASSIGNMENTS FOR PIN 1 ORIENTATION IN TAPE



*All dimensions are nominal

Device	Package Type	Package Drawing	Pins	SPQ	Reel Diameter (mm)	Reel Width W1 (mm)	A0 (mm)	B0 (mm)	K0 (mm)	P1 (mm)	W (mm)	Pin1 Quadrant
HD3SS6126RUAR	WQFN	RUA	42	3000	330.0	16.4	3.8	9.3	1.0	8.0	16.0	Q1

TAPE AND REEL BOX DIMENSIONS



*All dimensions are nominal

Device	Package Type	Package Drawing	Pins	SPQ	Length (mm)	Width (mm)	Height (mm)
HD3SS6126RUAR	WQFN	RUA	42	3000	367.0	367.0	38.0

GENERIC PACKAGE VIEW

RUA 42

WQFN - 0.8 mm max height

9 x 3.5, 0.5 mm pitch

PLASTIC QUAD FLATPACK - NO LEAD

This image is a representation of the package family, actual package may vary.
Refer to the product data sheet for package details.

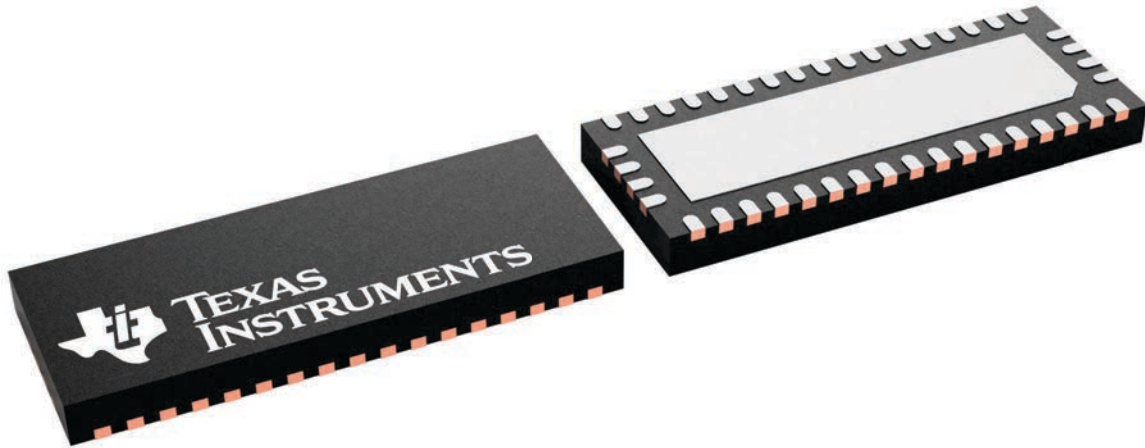

4226504/A

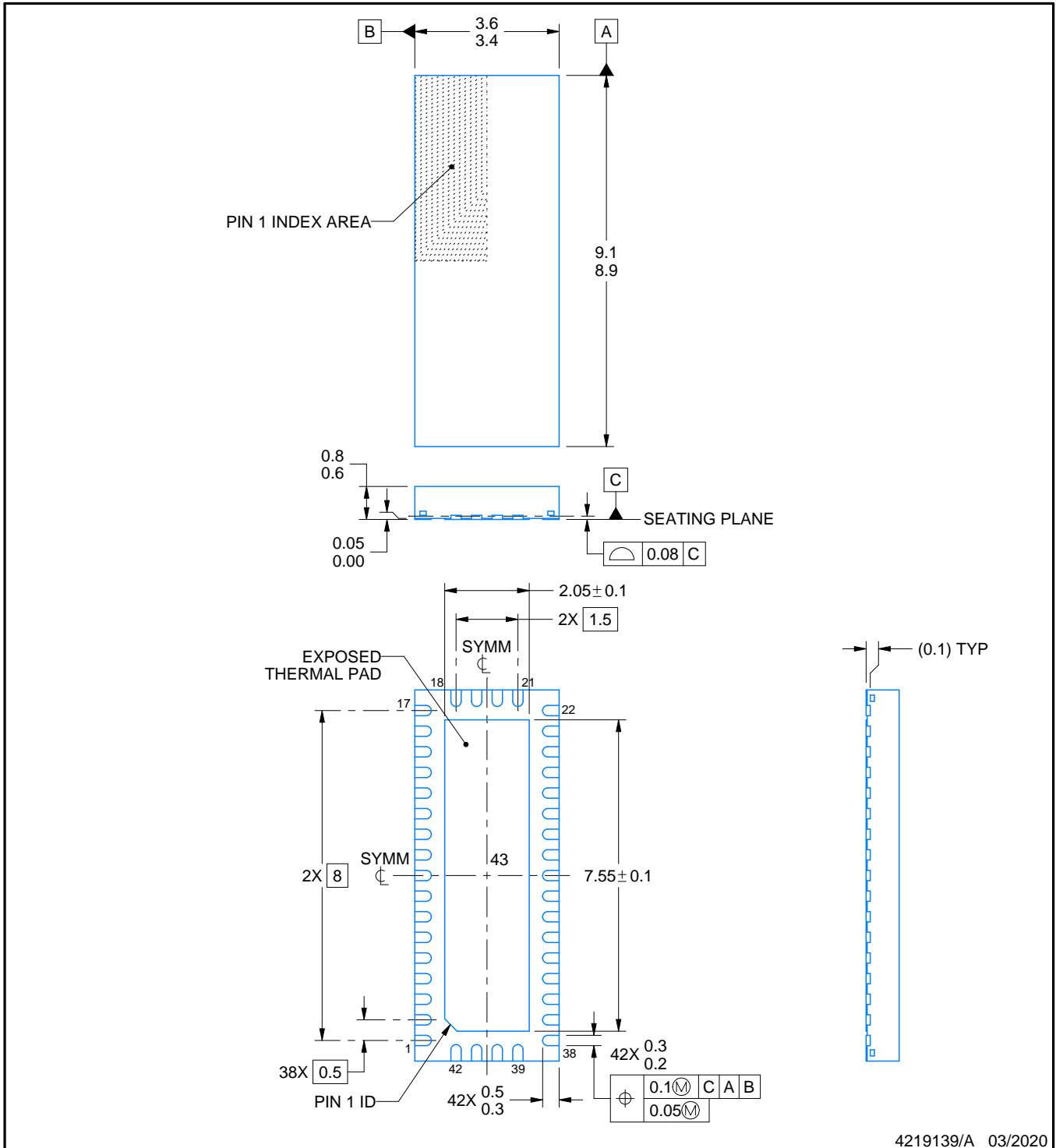

4219139/A 03/2020

NOTES:

1. All linear dimensions are in millimeters. Any dimensions in parenthesis are for reference only. Dimensioning and tolerancing per ASME Y14.5M.
2. This drawing is subject to change without notice.
3. The package thermal pad must be soldered to the printed circuit board for thermal and mechanical performance.

EXAMPLE BOARD LAYOUT

RUA0042A

WQFN - 0.8 mm max height

PLASTIC QUAD FLATPACK - NO LEAD

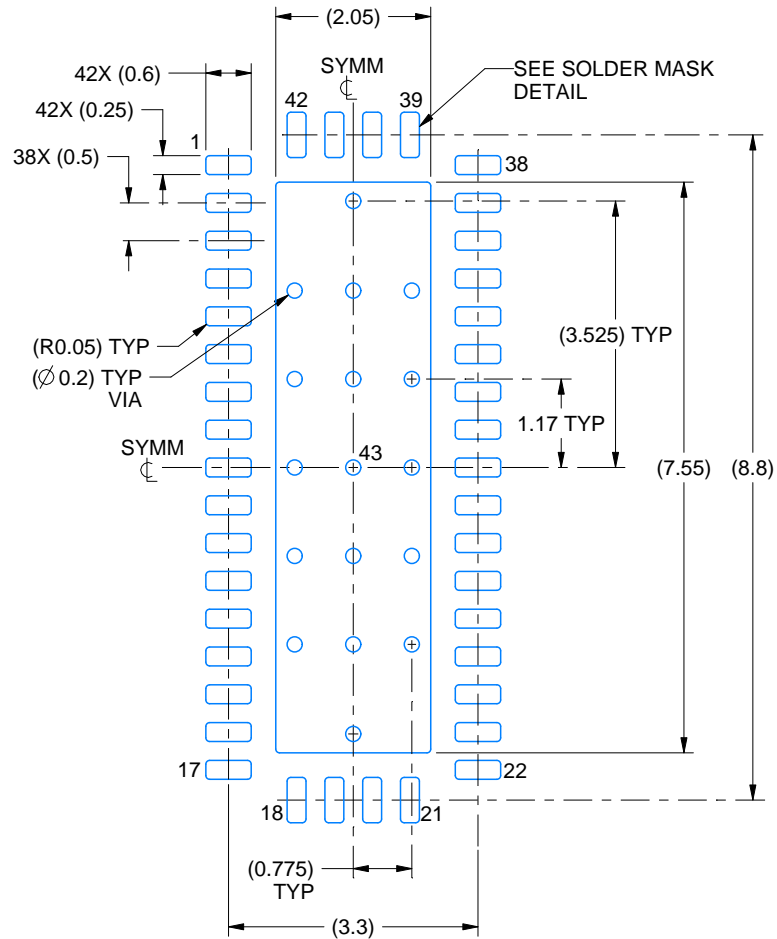

LAND PATTERN EXAMPLE
EXPOSED METAL SHOWN
SCALE: 10X

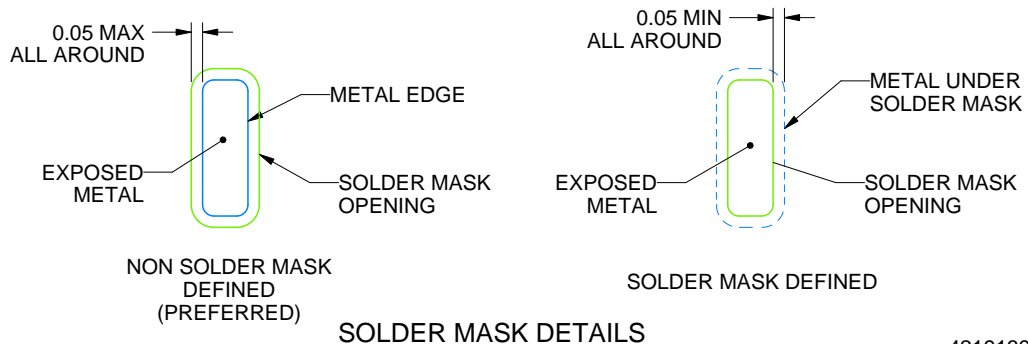

4219139/A 03/2020

NOTES: (continued)

- This package is designed to be soldered to a thermal pad on the board. For more information, see Texas Instruments literature number SLUA271 (www.ti.com/lit/sluea271).
- Vias are optional depending on application, refer to device data sheet. If any vias are implemented, refer to their locations shown on this view. It is recommended that vias under paste be filled, plugged or tented.

EXAMPLE STENCIL DESIGN

RUA0042A

WQFN - 0.8 mm max height

PLASTIC QUAD FLATPACK - NO LEAD

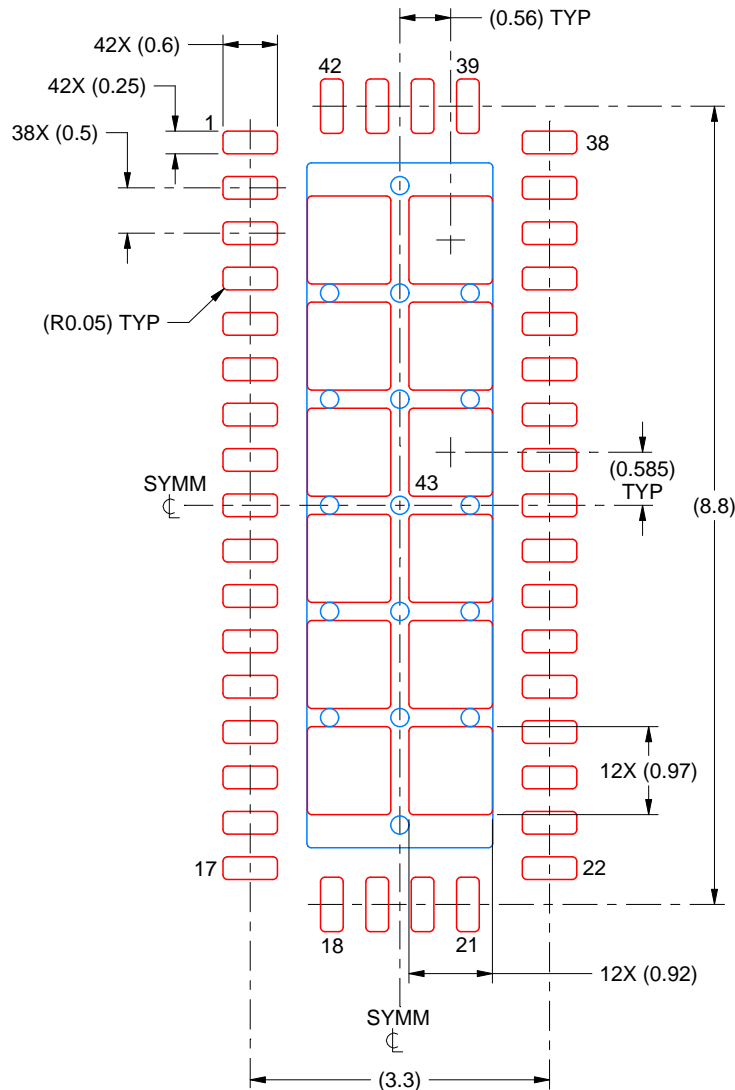

SOLDER PASTE EXAMPLE
BASED ON 0.125 MM THICK STENCIL
SCALE: 12X

EXPOSED PAD 43
69% PRINTED SOLDER COVERAGE BY AREA UNDER PACKAGE

4219139/A 03/2020

NOTES: (continued)

6. Laser cutting apertures with trapezoidal walls and rounded corners may offer better paste release. IPC-7525 may have alternate design recommendations.

IMPORTANT NOTICE AND DISCLAIMER

TI PROVIDES TECHNICAL AND RELIABILITY DATA (INCLUDING DATASHEETS), DESIGN RESOURCES (INCLUDING REFERENCE DESIGNS), APPLICATION OR OTHER DESIGN ADVICE, WEB TOOLS, SAFETY INFORMATION, AND OTHER RESOURCES "AS IS" AND WITH ALL FAULTS, AND DISCLAIMS ALL WARRANTIES, EXPRESS AND IMPLIED, INCLUDING WITHOUT LIMITATION ANY IMPLIED WARRANTIES OF MERCHANTABILITY, FITNESS FOR A PARTICULAR PURPOSE OR NON-INFRINGEMENT OF THIRD PARTY INTELLECTUAL PROPERTY RIGHTS.

These resources are intended for skilled developers designing with TI products. You are solely responsible for (1) selecting the appropriate TI products for your application, (2) designing, validating and testing your application, and (3) ensuring your application meets applicable standards, and any other safety, security, or other requirements. These resources are subject to change without notice. TI grants you permission to use these resources only for development of an application that uses the TI products described in the resource. Other reproduction and display of these resources is prohibited. No license is granted to any other TI intellectual property right or to any third party intellectual property right. TI disclaims responsibility for, and you will fully indemnify TI and its representatives against, any claims, damages, costs, losses, and liabilities arising out of your use of these resources.

TI's products are provided subject to TI's Terms of Sale (<https://www.ti.com/legal/termsofsale.html>) or other applicable terms available either on [ti.com](https://www.ti.com) or provided in conjunction with such TI products. TI's provision of these resources does not expand or otherwise alter TI's applicable warranties or warranty disclaimers for TI products.

Mailing Address: Texas Instruments, Post Office Box 655303, Dallas, Texas 75265
Copyright © 2021, Texas Instruments Incorporated