

To our customers,

Old Company Name in Catalogs and Other Documents

On April 1st, 2010, NEC Electronics Corporation merged with Renesas Technology Corporation, and Renesas Electronics Corporation took over all the business of both companies. Therefore, although the old company name remains in this document, it is a valid Renesas Electronics document. We appreciate your understanding.

Renesas Electronics website: <http://www.renesas.com>

April 1st, 2010
Renesas Electronics Corporation

Issued by: Renesas Electronics Corporation (<http://www.renesas.com>)

Send any inquiries to <http://www.renesas.com/inquiry>.

EOL product

RENESAS

Notice

1. All information included in this document is current as of the date this document is issued. Such information, however, is subject to change without any prior notice. Before purchasing or using any Renesas Electronics products listed herein, please confirm the latest product information with a Renesas Electronics sales office. Also, please pay regular and careful attention to additional and different information to be disclosed by Renesas Electronics such as that disclosed through our website.
2. Renesas Electronics does not assume any liability for infringement of patents, copyrights, or other intellectual property rights of third parties by or arising from the use of Renesas Electronics products or technical information described in this document. No license, express, implied or otherwise, is granted hereby under any patents, copyrights or other intellectual property rights of Renesas Electronics or others.
3. You should not alter, modify, copy, or otherwise misappropriate any Renesas Electronics product, whether in whole or in part.
4. Descriptions of circuits, software and other related information in this document are provided only to illustrate the operation of semiconductor products and application examples. You are fully responsible for the incorporation of these circuits, software, and information in the design of your equipment. Renesas Electronics assumes no responsibility for any losses incurred by you or third parties arising from the use of these circuits, software, or information.
5. When exporting the products or technology described in this document, you should comply with the applicable export control laws and regulations and follow the procedures required by such laws and regulations. You should not use Renesas Electronics products or the technology described in this document for any purpose relating to military applications or use by the military, including but not limited to the development of weapons of mass destruction. Renesas Electronics products and technology may not be used for or incorporated into any products or systems whose manufacture, use, or sale is prohibited under any applicable domestic or foreign laws or regulations.
6. Renesas Electronics has used reasonable care in preparing the information included in this document, but Renesas Electronics does not warrant that such information is error free. Renesas Electronics assumes no liability whatsoever for any damages incurred by you resulting from errors in or omissions from the information included herein.
7. Renesas Electronics products are classified according to the following three quality grades: “Standard”, “High Quality”, and “Specific”. The recommended applications for each Renesas Electronics product depends on the product’s quality grade, as indicated below. You must check the quality grade of each Renesas Electronics product before using it in a particular application. You may not use any Renesas Electronics product for any application categorized as “Specific” without the prior written consent of Renesas Electronics. Further, you may not use any Renesas Electronics product for any application for which it is not intended without the prior written consent of Renesas Electronics. Renesas Electronics shall not be in any way liable for any damages or losses incurred by you or third parties arising from the use of any Renesas Electronics product for an application categorized as “Specific” or for which the product is not intended where you have failed to obtain the prior written consent of Renesas Electronics. The quality grade of each Renesas Electronics product is “Standard” unless otherwise expressly specified in a Renesas Electronics data sheets or data books, etc.
 - “Standard”: Computers; office equipment; communications equipment; test and measurement equipment; audio and visual equipment; home electronic appliances; machine tools; personal electronic equipment; and industrial robots.
 - “High Quality”: Transportation equipment (automobiles, trains, ships, etc.); traffic control systems; anti-disaster systems; anti-crime systems; safety equipment; and medical equipment not specifically designed for life support.
 - “Specific”: Aircraft; aerospace equipment; submersible repeaters; nuclear reactor control systems; medical equipment or systems for life support (e.g. artificial life support devices or systems), surgical implantations, or healthcare intervention (e.g. excision, etc.), and any other applications or purposes that pose a direct threat to human life.
8. You should use the Renesas Electronics products described in this document within the range specified by Renesas Electronics, especially with respect to the maximum rating, operating supply voltage range, movement power voltage range, heat radiation characteristics, installation and other product characteristics. Renesas Electronics shall have no liability for malfunctions or damages arising out of the use of Renesas Electronics products beyond such specified ranges.
9. Although Renesas Electronics endeavors to improve the quality and reliability of its products, semiconductor products have specific characteristics such as the occurrence of failure at a certain rate and malfunctions under certain use conditions. Further, Renesas Electronics products are not subject to radiation resistance design. Please be sure to implement safety measures to guard them against the possibility of physical injury, and injury or damage caused by fire in the event of the failure of a Renesas Electronics product, such as safety design for hardware and software including but not limited to redundancy, fire control and malfunction prevention, appropriate treatment for aging degradation or any other appropriate measures. Because the evaluation of microcomputer software alone is very difficult, please evaluate the safety of the final products or system manufactured by you.
10. Please contact a Renesas Electronics sales office for details as to environmental matters such as the environmental compatibility of each Renesas Electronics product. Please use Renesas Electronics products in compliance with all applicable laws and regulations that regulate the inclusion or use of controlled substances, including without limitation, the EU RoHS Directive. Renesas Electronics assumes no liability for damages or losses occurring as a result of your noncompliance with applicable laws and regulations.
11. This document may not be reproduced or duplicated, in any form, in whole or in part, without prior written consent of Renesas Electronics.
12. Please contact a Renesas Electronics sales office if you have any questions regarding the information contained in this document or Renesas Electronics products, or if you have any other inquiries.

(Note 1) “Renesas Electronics” as used in this document means Renesas Electronics Corporation and also includes its majority-owned subsidiaries.

(Note 2) “Renesas Electronics product(s)” means any product developed or manufactured by or for Renesas Electronics.

To all our customers

Regarding the change of names mentioned in the document, such as Hitachi Electric and Hitachi XX, to Renesas Technology Corp.

The semiconductor operations of Mitsubishi Electric and Hitachi were transferred to Renesas Technology Corporation on April 1st 2003. These operations include microcomputer, logic, analog and discrete devices, and memory chips other than DRAMs (flash memory, SRAMs etc.) Accordingly, although Hitachi, Hitachi, Ltd., Hitachi Semiconductors, and other Hitachi brand names are mentioned in the document, these names have in fact all been changed to Renesas Technology Corp. Thank you for your understanding. Except for our corporate trademark, logo and corporate statement, no changes whatsoever have been made to the contents of the document, and these changes do not constitute any alteration to the contents of the document itself.

Renesas Technology Home Page: <http://www.renesas.com>

Renesas Technology Corp.
Customer Support Dept.
April 1, 2003

Cautions

Keep safety first in your circuit designs!

1. Renesas Technology Corporation puts the maximum effort into making semiconductor products better and more reliable, but there is always the possibility that trouble may occur with them. Trouble with semiconductors may lead to personal injury, fire or property damage.

Remember to give due consideration to safety when making your circuit designs, with appropriate measures such as (i) placement of substitutive, auxiliary circuits, (ii) use of nonflammable material or (iii) prevention against any malfunction or mishap.

Notes regarding these materials

1. These materials are intended as a reference to assist our customers in the selection of the Renesas Technology Corporation product best suited to the customer's application; they do not convey any license under any intellectual property rights, or any other rights, belonging to Renesas Technology Corporation or a third party.
2. Renesas Technology Corporation assumes no responsibility for any damage, or infringement of any third-party's rights, originating in the use of any product data, diagrams, charts, programs, algorithms, or circuit application examples contained in these materials.
3. All information contained in these materials, including product data, diagrams, charts, programs and algorithms represents information on products at the time of publication of these materials, and are subject to change by Renesas Technology Corporation without notice due to product improvements or other reasons. It is therefore recommended that customers contact Renesas Technology Corporation or an authorized Renesas Technology Corporation product distributor for the latest product information before purchasing a product listed herein.
The information described here may contain technical inaccuracies or typographical errors. Renesas Technology Corporation assumes no responsibility for any damage, liability, or other loss rising from these inaccuracies or errors.
Please also pay attention to information published by Renesas Technology Corporation by various means, including the Renesas Technology Corporation Semiconductor home page (<http://www.renesas.com>).
4. When using any or all of the information contained in these materials, including product data, diagrams, charts, programs, and algorithms, please be sure to evaluate all information as a total system before making a final decision on the applicability of the information and products. Renesas Technology Corporation assumes no responsibility for any damage, liability or other loss resulting from the information contained herein.
5. Renesas Technology Corporation semiconductors are not designed or manufactured for use in a device or system that is used under circumstances in which human life is potentially at stake. Please contact Renesas Technology Corporation or an authorized Renesas Technology Corporation product distributor when considering the use of a product contained herein for any specific purposes, such as apparatus or systems for transportation, vehicular, medical, aerospace, nuclear, or undersea repeater use.
6. The prior written approval of Renesas Technology Corporation is necessary to reprint or reproduce in whole or in part these materials.
7. If these products or technologies are subject to the Japanese export control restrictions, they must be exported under a license from the Japanese government and cannot be imported into a country other than the approved destination.
Any diversion or reexport contrary to the export control laws and regulations of Japan and/or the country of destination is prohibited.
8. Please contact Renesas Technology Corporation for further details on these materials or the products contained therein.

HD404818 Series

4-Bit Single-Chip Microcomputer

RENESAS

Preliminary
Rev. 2.0
Sept. 1998

Description

The HD404818 Series of 4-bit single-chip HMCS400 series microcomputers provide high program productivity. It incorporates a large size memory, LCD controller/driver, voltage comparator, and 32-kHz watch oscillator circuit.

The HD404818 Series has both standard voltage versions and low voltage versions available. The standard voltage versions operate at 4.0 V to 6.0 V (mask ROM version) and 4.0 V to 5.5 V (PROM version), while the low voltage versions operate at 2.7 V to 6.0 V (mask ROM) and 3.0 V to 5.5 V (PROM). Low voltage versions include an L in their product name.

Standard voltage versions: HD404812, HD404814, HD404816, HD404818, HD4074818

Low voltage versions: HD40L4812, HD40L4814, HD40L4816, HD40L4818, HD407L4818

The HD4074818 and HD407L4818, containing PROMs, are ZTAT™ microcomputers which can dramatically shorten system development time and smoothly proceed from debugging to mass production.

ZTAT™ : Zero Turn Around Time ZTAT is a trademark of Hitachi Ltd.

Features

- 2048-word × 10-bit ROM (HD404812, HD40L4812)
- 4096-word × 10-bit ROM (HD404814, HD40L4814)
- 6144-word × 10-bit ROM (HD404816, HD40L4816)
- 8192-word × 10-bit ROM (HD404818, HD40L4818, HD4074818, HD407L4818)
- 1184-digit × 4-bit RAM
- 30 I/O pins, including 10 high-current output pins, all CMOS and programmable as I/O pull-up MOS
- LCD controller/driver (32 segments × 4 commons)
- Three timer/counters
- Clock-synchronous 8-bit serial interface
- Six interrupt sources
 - Two by external sources
 - Four by internal sources

HD404818 Series

- Subroutine stack up to 16 levels, including interrupts
- Instruction cycle time:
 - 1 μs ($f_{\text{OSC}} = 4 \text{ MHz}$ for HD404812/HD404814/HD404816/HD404818/HD4074818)
 - 5 μs ($f_{\text{OSC}} = 800 \text{ kHz}$ for HD40L4812/HD40L4814/HD40L4816/HD40L4818/HD407L4818)
- Four low-power dissipation modes
 - Standby mode
 - Stop mode
 - Watch mode
 - Subactive mode
- Internal oscillator:
 - Main clock: Can be driven by ceramic oscillator, crystal oscillator, or external clock
 - Subclock: 32.768-kHz crystal
- Voltage comparator (2 channels)
- Package
 - 80-pin plastic flat package (FP-80B, FP-80A)
 - 80-pin plastic thin flat package (TFP-80)

HD404818 Series

Ordering Information

Type	Supply Voltage	Product Name	Model Name	ROM (Word)	Clock Frequency	Package	
Mask ROM	Standard (4.0 to 6.0 V)	HD404812	HD404812FS	2,048	4	FP-80B	
			HD404812H			FP-80A	
			HD404812TF			TFP-80	
		HD404814	HD404814FS	4,096		FP-80B	
			HD404814H			FP-80A	
			HD404814TF			TFP-80	
		HD404816	HD404816FS	6,144		FP-80B	
			HD404816H			FP-80A	
			HD404816TF			TFP-80	
	HD404818	HD404818FS	8,192	FP-80B			
		HD404818H		FP-80A			
		HD404818TF		TFP-80			
	Low-voltage operation (2.7 to 6.0 V)	HD40L4812	HD40L4812	HD40L4812FS	2,048	0.8	FP-80B
				HD40L4812H			FP-80A
				HD40L4812TF			TFP-80
HD40L4814			HD40L4814FS	4,096	FP-80B		
			HD40L4814H		FP-80A		
			HD40L4814TF		TFP-80		
HD40L4816			HD40L4816FS	6,144	FP-80B		
			HD40L4816H		FP-80A		
			HD40L4816TF		TFP-80		
HD40L4818		HD40L4818FS	8,192	FP-80B			
		HD40L4818H		FP-80A			
		HD40L4818TF		TFP-80			
ZTAT™		Standard (4.0 to 5.5 V)	HD4074818	HD4074818FS	8,192	4	FP-80B
				HD4074818H			FP-80A
				HD4074818TF			TFP-80
	Low-voltage operation (3.0 to 5.5 V)	HD407L4818	HD407L4818FS	0.8	FP-80B		
			HD407L4818H		FP-80A		
			HD407L4818TF		TFP-80		

HD404818 Series

Pin Description

Pin Number				Pin Number			
FP-80B	FP-80A, TFP-80	Pin Name	I/O	FP-80B	FP-80A, TFP-80	Pin Name	I/O
1	79	D ₂	I/O	31	29	R3 ₂ /INT ₀	I/O
2	80	D ₃	I/O	32	30	R3 ₃ /INT ₁	I/O
3	1	D ₄	I/O	33	31	SEG1	O
4	2	D ₅	I/O	34	32	SEG2	O
5	3	D ₆	I/O	35	33	SEG3	O
6	4	D ₇	I/O	36	34	SEG4	O
7	5	D ₈	I/O	37	35	SEG5	O
8	6	D ₉	I/O	38	36	SEG6	O
9	7	D ₁₀	I	39	37	SEG7	O
10	8	D ₁₁ /VC _{ref}	I	40	38	SEG8	O
11	9	D ₁₂ /COMP ₀	I	41	39	SEG9	O
12	10	D ₁₃ /COMP ₁	I	42	40	SEG10	O
13	11	TEST	I	43	41	SEG11	O
14	12	X1	I	44	42	SEG12	O
15	13	X2	O	45	43	SEG13	O
16	14	GND		46	44	SEG14	O
17	15	R0 ₀ /SCK	I/O	47	45	SEG15	O
18	16	R0 ₁ /SI	I/O	48	46	SEG16	O
19	17	R0 ₂ /SO	I/O	49	47	SEG17	O
20	18	R0 ₃	I/O	50	48	SEG18	O
21	19	R1 ₀	I/O	51	49	SEG19	O
22	20	R1 ₁	I/O	52	50	SEG20	O
23	21	R1 ₂	I/O	53	51	SEG21	O
24	22	R1 ₃	I/O	54	52	SEG22	O
25	23	R2 ₀	I/O	55	53	SEG23	O
26	24	R2 ₁	I/O	56	54	SEG24	O
27	25	R2 ₂	I/O	57	55	SEG25	O
28	26	R2 ₃	I/O	58	56	SEG26	O
29	27	R3 ₀	I/O	59	57	SEG27	O
30	28	R3 ₁ /TIMO	I/O	60	58	SEG28	O

HD404818 Series

Pin Number				Pin Number			
FP-80B	FP-80A, TFP-80	Pin Name	I/O	FP-80B	FP-80A, TFP-80	Pin Name	I/O
61	59	SEG29	O	71	69	V ₃	
62	60	SEG30	O	72	70	NUMO	
63	61	SEG31	O	73	71	NUMO	
64	62	SEG32	O	74	72	NUMG	
65	63	COM1	O	75	73	V _{CC}	
66	64	COM2	O	76	74	OSC ₁	I
67	65	COM3	O	77	75	OSC ₂	O
68	66	COM4	O	78	76	RESET	I
69	67	V ₁		79	77	D ₀	I/O
70	68	V ₂		80	78	D ₁	I/O

Note: I/O: Input/output pin, I: Input pin, O: Output pin, NUMO: Open, NUMG: GND

Pin Functions

Power Supply

V_{CC}: Apply the V_{CC} power supply voltage to this pin.

GND: Connect to ground.

$\overline{\text{TEST}}$: For test purposes only. Connect it to V_{CC}.

RESET: MCU reset pin. Refer to the Reset section for details.

NUMG: Non-user pin. Connect it to GND.

NUMO: Non-user pin. Do not connect it to any lines.

Oscillators

OSC₁, OSC₂: Internal oscillator input pins. They both can be connected to a crystal, ceramic resonator, or external oscillator circuit. Refer to the Internal Oscillator Circuit section for details.

X1, X2: Watch oscillator 32-kHz crystal pins.

Ports

D₀–D₁₃ (D Port): Fourteen 1-bit I/O ports. D₀ to D₉ are I/O ports and D₁₀ to D₁₃ are input ports. D₀–D₉ are high current output ports (15 mA max.). D₁₁–D₁₃ are also available as voltage comparators. Refer to the Input/Output section for details.

R0–R3 (R Ports): 4-bit I/O ports. R₀, R₀₁, R₀₂, R₃₁, R₃₂, and R₃₃ are multiplexed with $\overline{\text{SCK}}$, SI, SO, TIMO, $\overline{\text{INT}}_0$, and $\overline{\text{INT}}_1$, respectively.

Interrupts

$\overline{\text{INT}}_0$, $\overline{\text{INT}}_1$: External interrupt pins. $\overline{\text{INT}}_1$ can be used as an external event input pin for timer B. $\overline{\text{INT}}_0$ and $\overline{\text{INT}}_1$ are multiplexed with R₃₂ and R₃₃, respectively. For details, see the Interrupts section.

Serial Interface

$\overline{\text{SCK}}$, SI, SO: The transmit clock I/O pin ($\overline{\text{SCK}}$), serial data input pin (SI), and serial data output pin (SO) are used for serial interface. $\overline{\text{SCK}}$, SI, and SO are multiplexed with R₀₀, R₀₁, and R₀₂, respectively. For details, see the Serial Interface section.

Timer

TIMO: Variable duty-cycle pulse waveform output pin. See the Timer C section for details.

HD404818 Series

LCD Driver/Controller

V₁, V₂, V₃: Power supply pins for the LCD driver. Since the LCD driving resistors are provided internally, no lines should be connected to these pins. The voltage on each pin is $V_{CC} \geq V_1 \geq V_2 \geq V_3 \geq GND$. See the Liquid Crystal Display section for details.

COM1 to COM4: Common signal output pins for the LCD display. See the Liquid Crystal Display section for details.

SEG1 to SEG32: Segment signals output pins for the LCD display. See the Liquid Crystal Display section for details.

Voltage Comparator

COMP₀, COMP₁, VC_{ref}: Analog input pins for the voltage comparator. VC_{ref} is used as a reference voltage pin to input the threshold voltage of the analog input pin.

Block Diagram

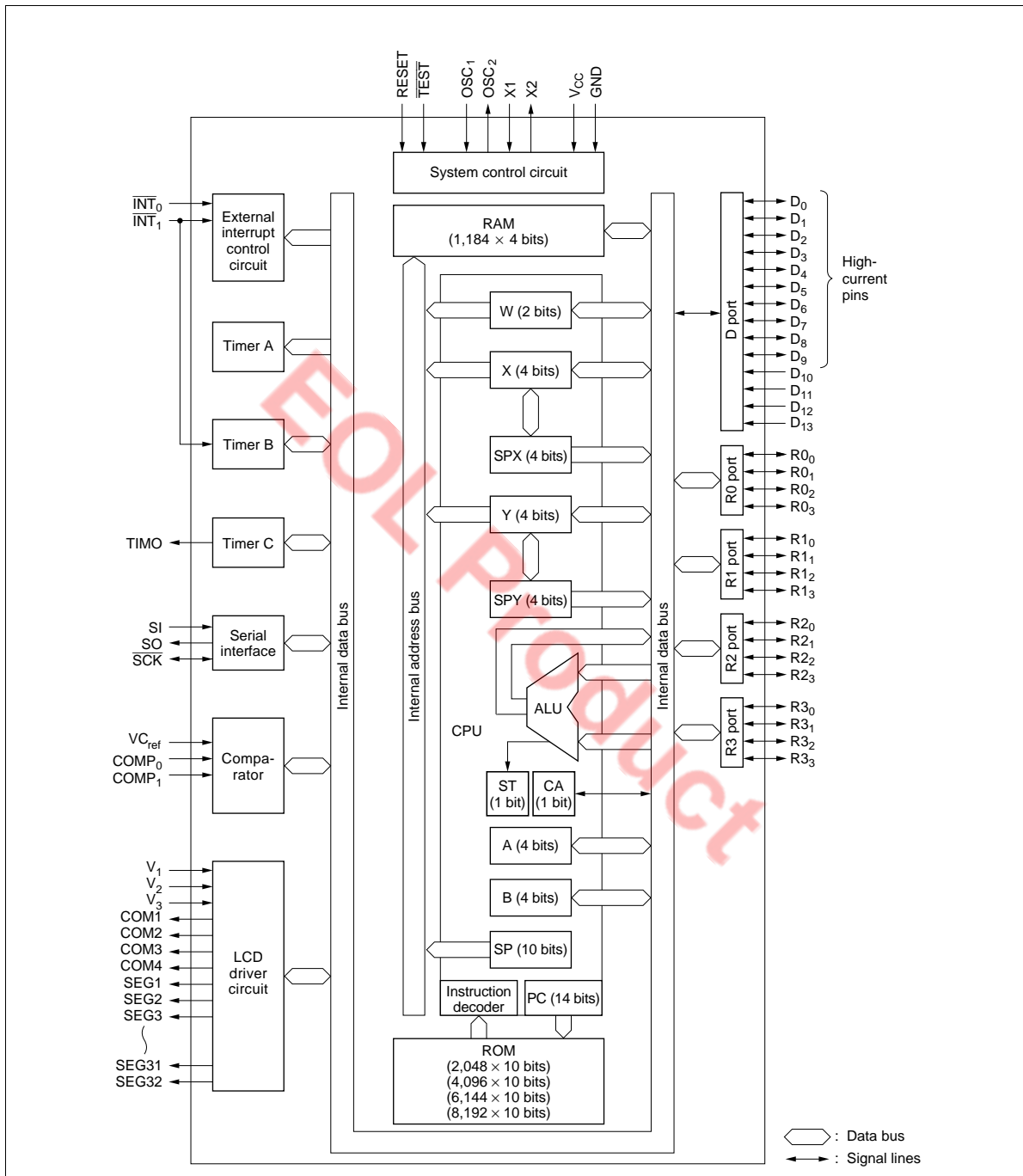

HD404818 Series

Memory Map

ROM Memory Map

The ROM is described in the following paragraphs with the ROM memory map in figure 1.

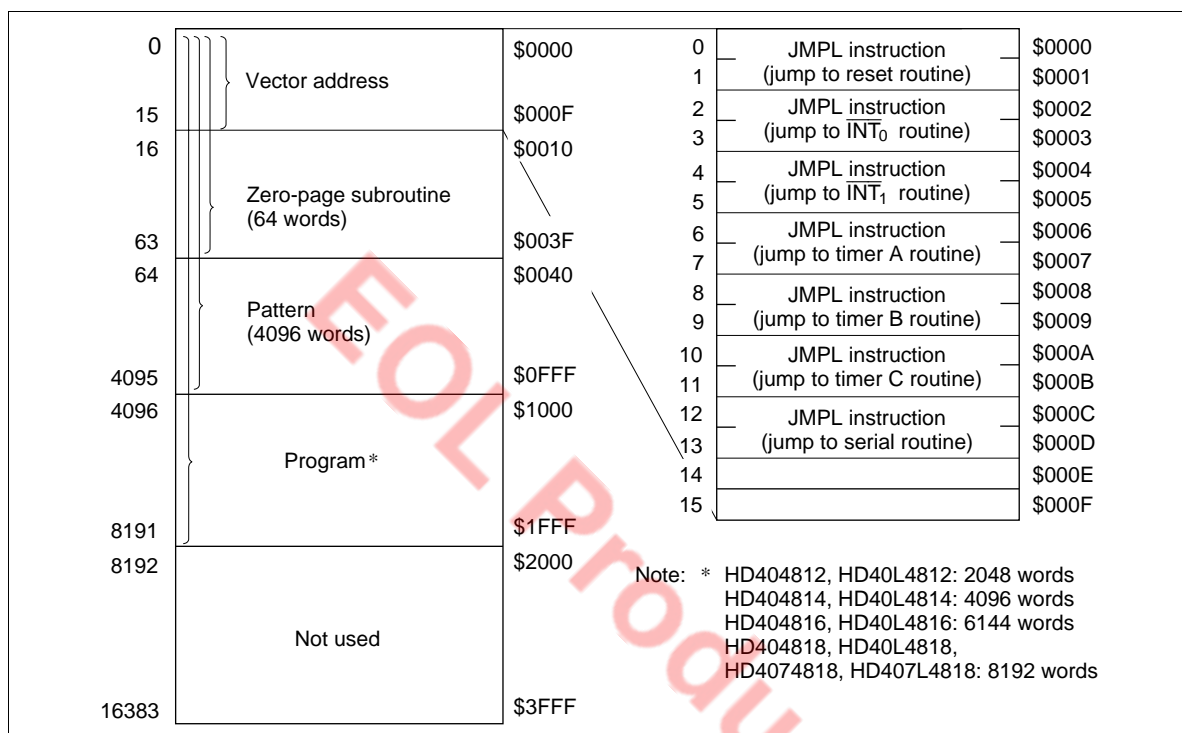

Figure 1 ROM Memory Map

Vector Address Area (\$0000 to \$000F): Locations \$0000 through \$000F are reserved for JMPL instructions to branch to the starting address of the initialization program and of the interrupt programs. After reset or an interrupt routine, the program is executed from the vector address.

Zero-Page Subroutine Area (\$0000 to \$003F): Locations \$0000 through \$003F are reserved for subroutines. The program sequence branches to subroutines by the CAL instruction.

Pattern Area (\$0000 to \$0FFF): Locations \$0000 through \$0FFF are reserved for ROM data. The P instruction allows the MCU to reference ROM data as a pattern.

Program Area (\$0000 to \$07FF: HD404812, HD40L4812; \$0000 to \$0FFF: HD404814, HD40L4814; \$0000 to \$17FF: HD404816, HD40L4816; \$0000 to \$1FFF: HD404818, HD40L4818, HD4074818, HD407L4818): Used for program coding.

RAM Memory Map

The MCU also contains a 1,184-digit \times 4-bit RAM as the data and stack area. In addition to these areas, interrupt control bits and special function registers are mapped on the RAM memory space. The RAM memory map (figure 2) is described in the following paragraphs.

Interrupt Control Bits Area (\$000 to \$003): The interrupt control bits area (figure 3) is used for interrupt control. It is accessible only by RAM bit manipulation instructions. However, the interrupt request flag cannot be set by software. The RSP bit is used only to reset the stack pointer.

Special Function Registers Area (\$004 to \$01F, \$024 to \$03F): The special function registers are the mode or data registers for the serial interface, timer/counters, LCD, and the data control registers for the I/O ports. These registers are classified into three types: write-only, read-only, and read/write as shown in figure 2.

The SEM/REM and SEMD/REMD instructions are available for the LCD control register (LCR).

Other registers cannot be accessed by RAM bit manipulation instructions.

Register Flag Area (\$020 to \$023): Consist of the LSON, WDON, TGSP, and DTON flags which are bit registers accessible by the RAM bit manipulation instruction.

The WDON flag can only be set, and only by the SEM/SEMD instruction.

The DTON flag can be set, reset, and tested by the SEM/SEMD, REM/REMD, and TMD instructions. Note that the DTON flag is active only in subactive mode, and is normally reset in active mode.

LCD Data Area (\$050 to \$06F): Locations \$050 to \$06F store the LCD data which is automatically transmitted to the segment driver as display data. The LCD is illuminated with 1s and faded with 0s. This area can be used as a data area.

Data Area (\$040 to \$2CF, \$100 to \$2CF; Bank 0/1): The 16 digits of \$040 through \$04F are called memory registers (MR) and are accessible by the LAMR and XMRA instructions (figure 4). 464 digits of \$100 through \$2CF are selected as bank 0 or 1 depending on the value of the V register.

Stack Area (\$3C0 to \$3FF): Locations \$3C0 through \$3FF are reserved for LIFO stacks to save the contents of the program counter (PC), status flag (ST), and carry flag (CA) when subroutine calls (CAL or CALL instruction) and interrupts are processed. This area can be used as a 16-level nesting stack in which one level requires 4 digits.

Figure 4 shows the save condition. The program counter is restored by the RTN and RTNI instructions. The status and carry flags are restored only by the RTNI instruction. This area, when not used as a stack, is available as a data area.

HD404818 Series

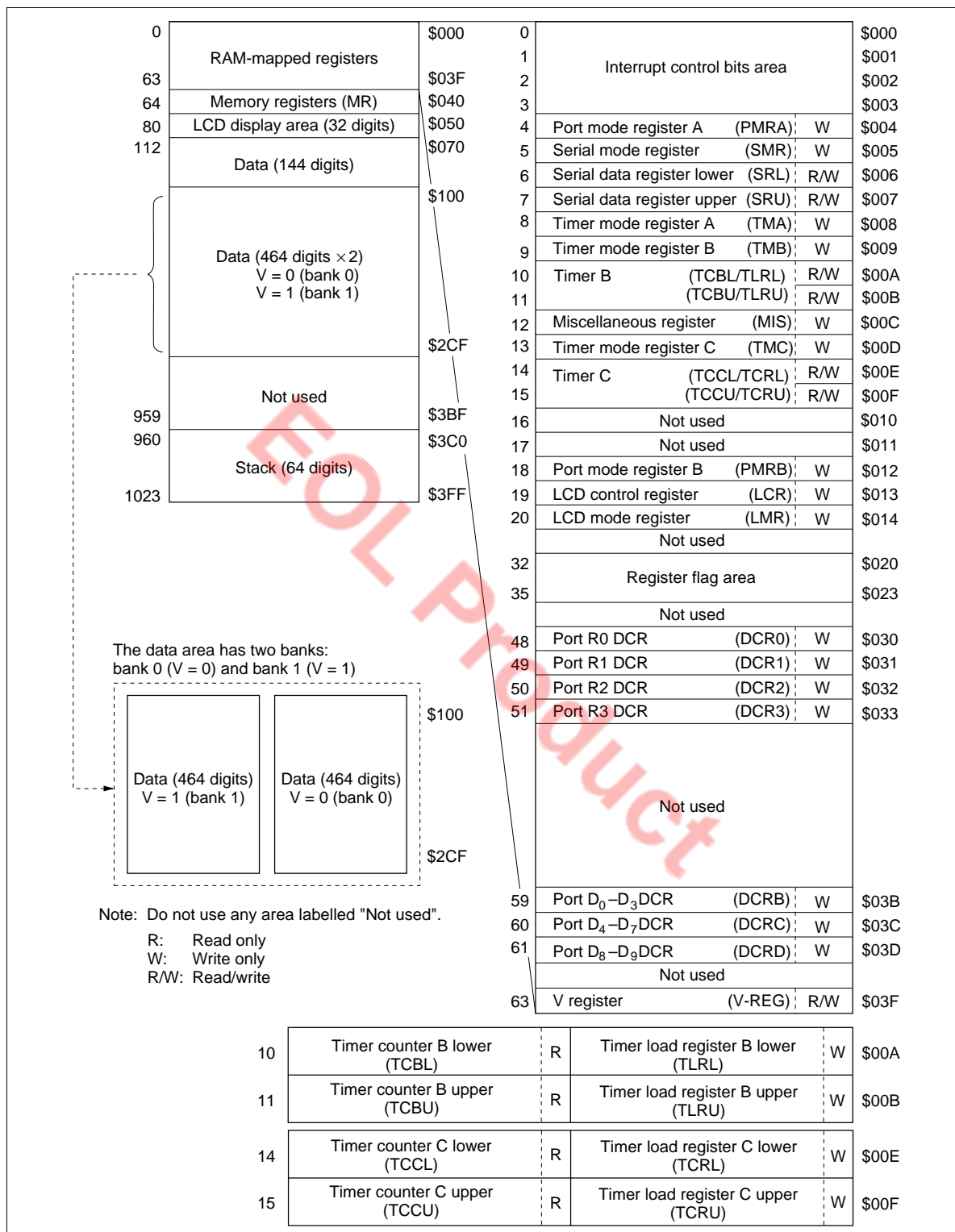

Figure 2 RAM Memory Map (1,184-digit x 4-bit)

	Bit 3	Bit 2	Bit 1	Bit 0	
0	IMO (IM of \overline{INT}_0)	IFO (IF of \overline{INT}_0)	RSP (Reset SP bit)	IE (Interrupt enable flag)	\$000
1	IMTA (IM of timer A)	IFTA (IF of timer A)	IM1 (IM of \overline{INT}_1)	IF1 (IF of \overline{INT}_1)	\$001
2	IMTC (IM of timer C)	IFTC (IF of timer C)	IMTB (IM of timer B)	IFTB (IF of timer B)	\$002
3	Not used	Not used	IMS (IM of serial)	IFS (IF of serial)	\$003
32	DTON Direct transfer on flag	Not used	WDON (Watchdog on flag)	LSON (Low speed on flag)	\$020
	Not used				\$021
	Not used				\$023

IF: Interrupt request flag
 IM: Interrupt mask
 IE: Interrupt enable flag
 SP: Stack pointer

Note: Bits in the interrupt control bits area and register flag area are set by the SEM or SEMD instruction, reset by the REM or REMD instruction, and tested by the TM or TMD instruction. Other instructions have no effect. However, note the following usage limitations of RAM bit manipulation instructions.

	SEM/SEMD	REM/REMD	TM/TMD
IF	Not executed	Allowed	Allowed
RSP	Not executed	Allowed	Inhibited
WDON	Allowed	Not executed	Inhibited
DTON	Not executed in active mode	Allowed	Allowed
	Used in subactive mode		

Note: WDON is reset only by MCU reset.
 DTON is always reset in active mode.
 If the TM or TMD instruction is executed for the inhibited bits or non-existing bits, the value in ST becomes invalid.

Figure 3 Configuration of Interrupt Control Bits and Register Flag Areas

HD404818 Series

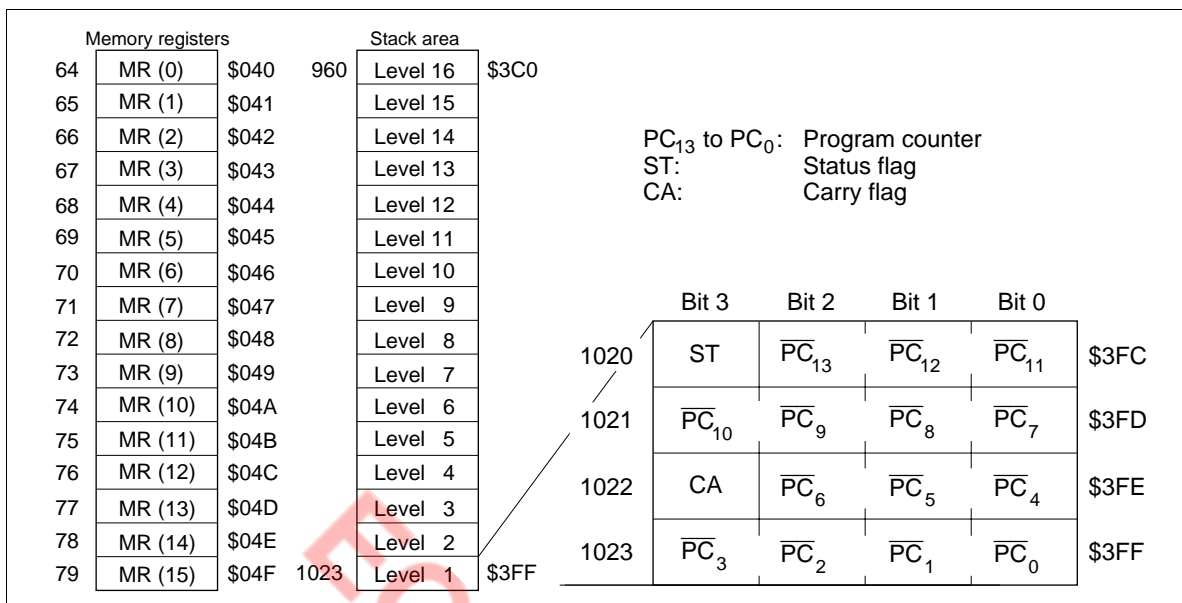

Figure 4 Configuration of Memory Registers, Stack Area, and Stack Position

Functional Description

Registers and Flags

The MCU provides ten registers and two flags for CPU operations. They are illustrated in figure 5 and described in the following paragraphs.

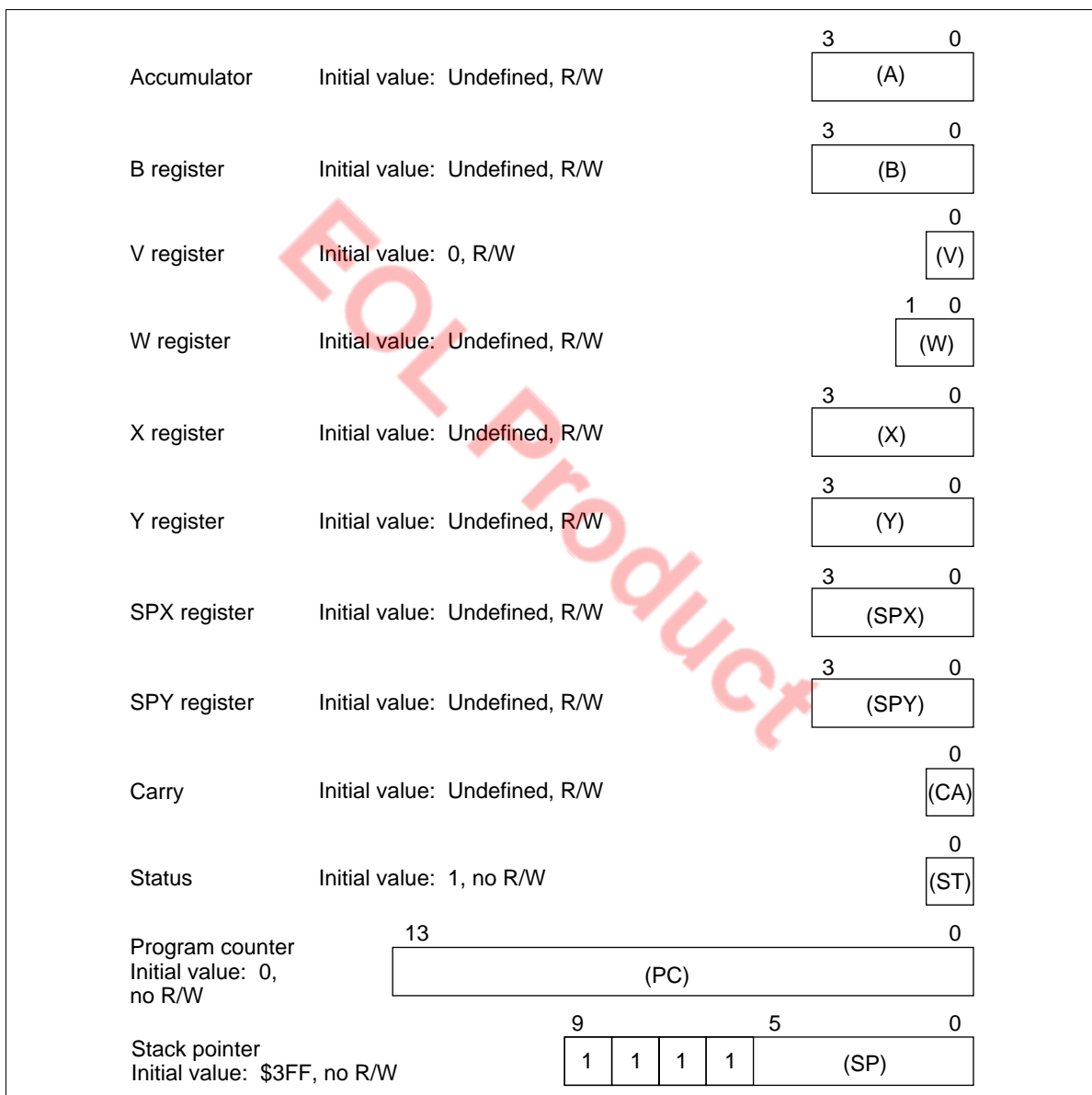

Figure 5 Registers and Flags

Accumulator (A), B Register (B): The accumulator and B register are 4-bit registers which hold the results of the arithmetic logic unit (ALU), and exchange data between memory, I/O, and other registers.

HD404818 Series

V Register (V): The V register, available for RAM address expansion, selects the bank of locations \$100–\$2CF on the RAM address (464 digits) depending on its value. Therefore, when accessing locations \$100–\$2CF on the RAM address, specify the value of the V register (V = \$0: bank 0; V = \$1: bank 1). Locations \$000–\$0FF and \$300–\$3FF can be accessed independently of the V register. The V register is located at \$03F of the RAM address area.

W Register (W), X Register (X), Y Register (Y): The 2-bit W register and 4-bit X and Y registers address RAM indirectly. The Y register is also available for addressing port D.

SPX Register (SPX), SPY Register (SPY): The 4-bit SPX and SPY registers are available for assisting the X and Y registers, respectively.

Carry Flag (CA): The carry flag holds the ALU overflow generated by an arithmetic operation. It is also affected by the SEC, REC, ROTL, and ROTR instructions. During an interrupt, the carry flag is pushed onto the stack and restored back from the stack by the RTNI instruction. (It is unaffected by the RTN instruction.)

Status Flag (ST): The status flag holds the ALU overflow, ALU non-zero, and the results of a bit test instruction for arithmetic or compare instructions. The status flag is a branch condition of the BR, BRL, CAL, or CALL instruction. The value of the status flag remains unchanged until an instruction which affects the next status is executed. The status flag becomes 1 after the BR, BRL, CAL, or CALL instruction is either executed or skipped. During an interrupt, the status flag is pushed onto the stack and restored back from the stack by the RTNI instruction, not by the RTN instruction.

Program Counter (PC): The program counter is a 14-bit binary counter for holding the ROM address.

Stack Pointer (SP): The stack pointer is a 10-bit register to indicate the next stacking area up to 16 levels. The stack pointer is initialized to RAM address \$3FF at MCU reset. It is decremented by 4 as data is pushed onto the stack, and incremented by 4 as data is restored back from the stack. The stack pointer is initialized to \$3FF either by MCU reset or by the RSP bit reset from the REM/REMD instruction.

Reset

Setting the RESET pin high resets the MCU. At power-on or when cancelling the stop mode for the oscillator, apply the reset input for at least t_{RC} for the oscillator to stabilize. In all other cases, at least two instruction cycles of reset input are required for the MCU reset.

Table 1 shows the components initialized by MCU reset, and each of its status.

Table 1 Initial Values after MCU Reset

Items	Initial Value	Contents
Program counter (PC)	\$0000	Execute program from the top of the ROM address
Status flag (ST)	1	Enable branching with conditional branch instructions
Stack pointer (SP)	\$3FF	Stack level is 0
V register (bank register) (V)	0	Bank 0 (memory)
Interrupt flags/mask	Interrupt enable flag (IE)	0 Inhibit all interrupts
	Interrupt request flag (IF)	0 No interrupt request
	Interrupt mask (IM)	1 Masks interrupt request
I/O	Port data register (PDR)	All bits are 1 Enable to transmit high
	Data control register (DCR)	All bits are 0 Output buffer is off (high impedance)
	Port mode register A (PMRA)	0000 See Port Mode Register A section
	Port mode register B (PMRB)	0000 See Port Mode Register B section
Timer/counters, serial interface	Timer mode register A (TMA)	0000 See Timer Mode Register A section
	Timer mode register B (TMB)	0000 See Timer Mode Register B section
	Timer mode register C (TMC)	0000 See Timer Mode Register C section
	Serial mode register (SMR)	0000 See Serial Mode Register section
	Prescaler S	\$000
	Prescaler W	\$00
	Timer counter A (TCA)	\$00
	Timer counter B (TCB)	\$00
	Timer counter C (TCC)	\$00
	Timer load register B (TLR)	\$00
Timer load register C (TCR)	\$00	
Octal counter	000	

HD404818 Series

Table 1 Initial Values after MCU Reset (cont)

Items		Initial Value	Contents
LCD	LCD control register (LCR)	000	Refer to description of LCD Control Register
	LCD mode register (LMR)	0000	Refer to description of LCD Duty/Clock Control
Bit register	Low speed on flag (LSON)	0	Refer to description of Low-Power Dissipation Mode
	Watchdog timer on flag (WDON)	0	Refer to description of Timer C
	Direct transfer on flag (DTON)	0	Refer to description of Low-Power Dissipation Mode
Miscellaneous register	(MIS)	000	—

Item	After MCU Reset to Recover from Stop Mode	After MCU Reset to Recover from Other Modes
Carry flag (CA)	The contents of the items before MCU reset are not retained. It is necessary to initialize them by software.	The contents of the items before MCU reset are not retained. It is necessary to initialize them by software.
Accumulator (A)		
B register (B)		
W register (W)		
X/SPX registers (X/SPX)		
Y/SPY registers (Y/SPY)		
Serial data register (SR)		
RAM	The contents of RAM before MCU reset (just before STOP instruction) are retained.	

Interrupts

Six interrupt sources are available on the MCU: external requests (\overline{INT}_0 , \overline{INT}_1), timer/counters (timers A, B, and C), and the serial interface. For each source, an interrupt request flag (IF), interrupt mask (IM), and interrupt vector addresses are provided to control and maintain the interrupt request. The interrupt enable flag (IE) is also used to control interrupt operations.

Interrupt Control Bits and Interrupt Servicing: The interrupt control bits are mapped on \$000 through \$003 by the RAM space. They are accessible by RAM bit manipulations instructions, although the interrupt request flag (IF) cannot be set by software. The interrupt enable flag (IE) and IF are cleared to 0, and the interrupt mask (IM) is set to 1 after MCU reset.

Figure 6 is a block diagram of the interrupt control circuit. Table 2 shows the interrupt priority and vector addresses, and table 3 shows the interrupt conditions corresponding to each interrupt source.

The interrupt request is generated when IF is set to 1 and IM is 0. If IE is 1 at this time, the interrupt will be activated and vector addresses will be generated from the priority PLA corresponding to the interrupt sources.

Pre-Product

HD404818 Series

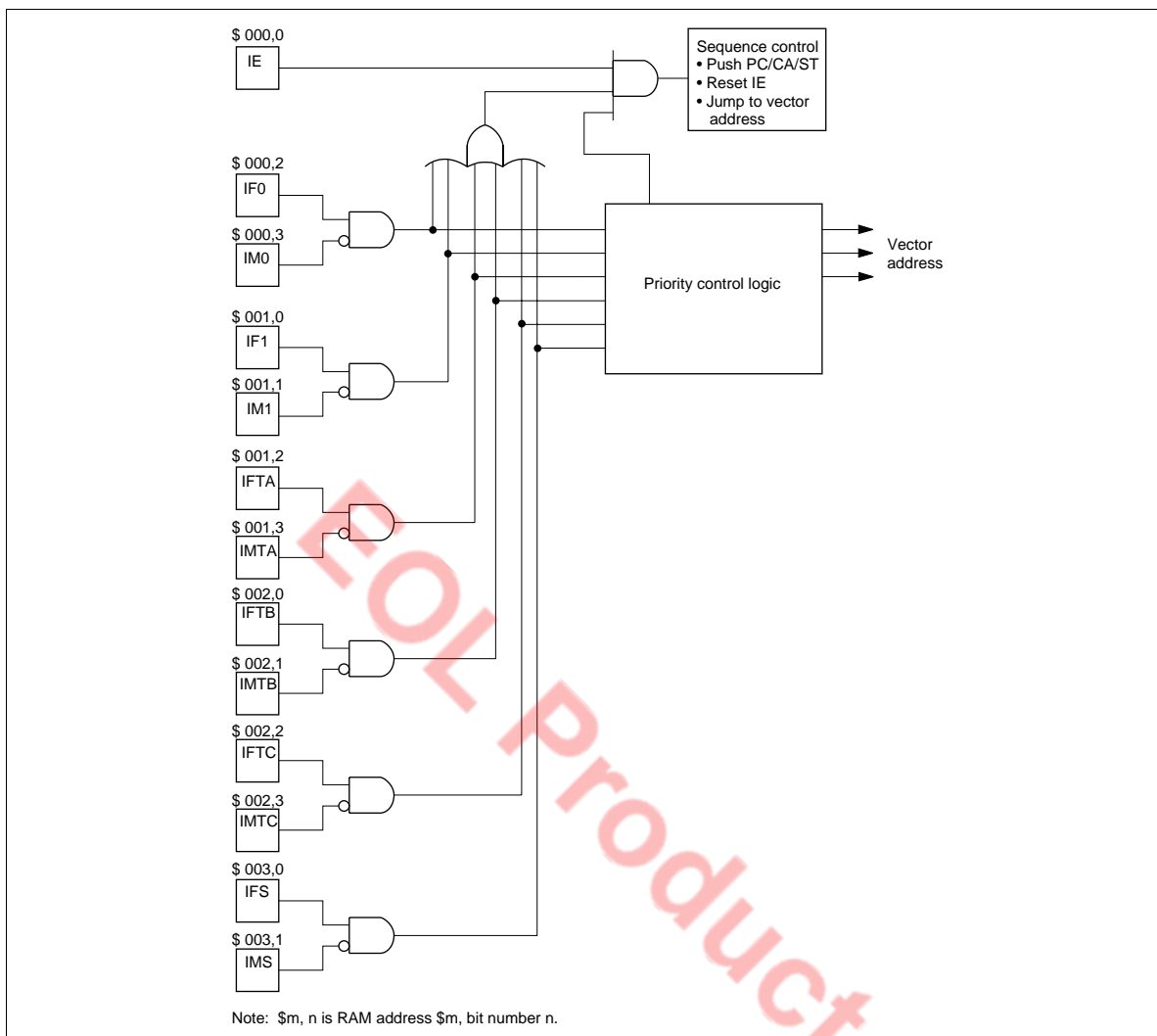

Figure 6 Interrupt Control Circuit Block Diagram

Table 2 Vector Addresses and Interrupt Priority

Reset/Interrupt	Priority	Vector Addresses
RESET	—	\$0000
\overline{INT}_0	1	\$0002
\overline{INT}_1	2	\$0004
Timer A	3	\$0006
Timer B	4	\$0008
Timer C	5	\$000A
Serial	6	\$000C

Table 3 Interrupt Conditions

Interrupt Control Bit	Interrupt Source					
	\overline{INT}_0	\overline{INT}_1	Timer A	Timer B	Timer C	Serial
IE	1	1	1	1	1	1
IF0 • \overline{IMO}	1	0	0	0	0	0
IF1 • $\overline{IM1}$	*	1	0	0	0	0
IFTA • \overline{IMTA}	*	*	1	0	0	0
IFTB • \overline{IMTB}	*	*	*	1	0	0
IFTC • \overline{IMTC}	*	*	*	*	1	0
IFS • \overline{IMS}	*	*	*	*	*	1

Note: *Don't care.

Figure 7 shows the interrupt processing sequence, and figure 8 shows the interrupt processing flowchart. If an interrupt is requested, the instruction being executed finishes in the first cycle. The IE is reset in the second cycle. In the second and third cycles, the carry flag, status flag, and program counter are pushed onto the stack. In the third cycle, the instruction is executed after jumping to the vector address.

In each vector address, program the JMPL instruction to branch to the starting address of the interrupt program. The IF, which caused the interrupt, must be reset by software in the interrupt program.

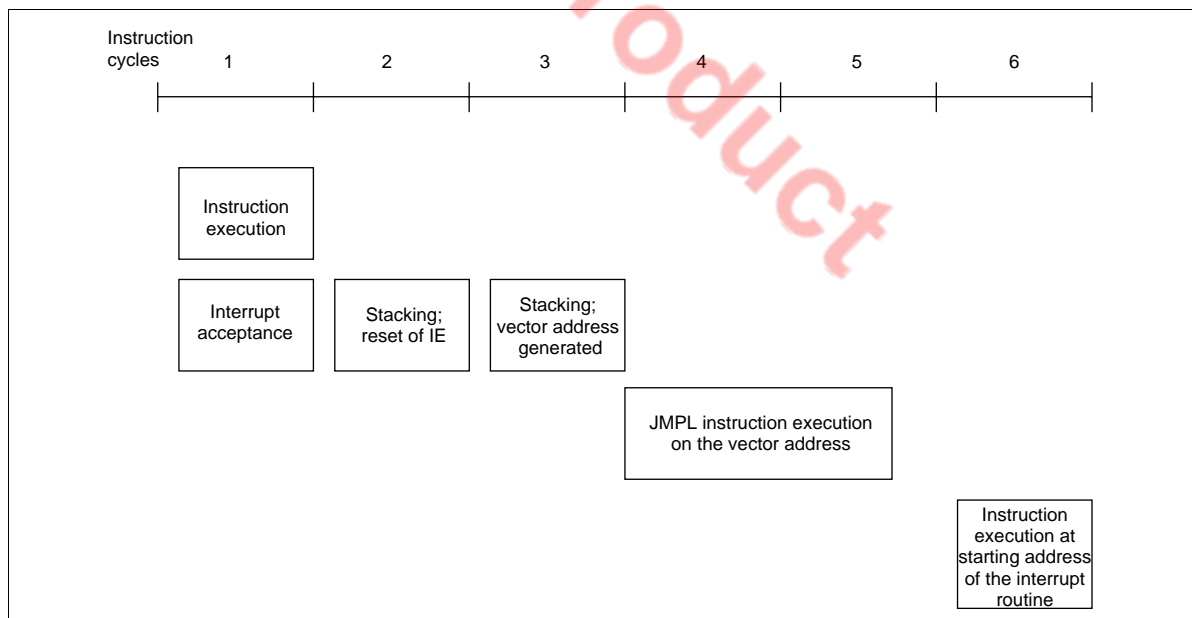

Figure 7 Interrupt Processing Sequence

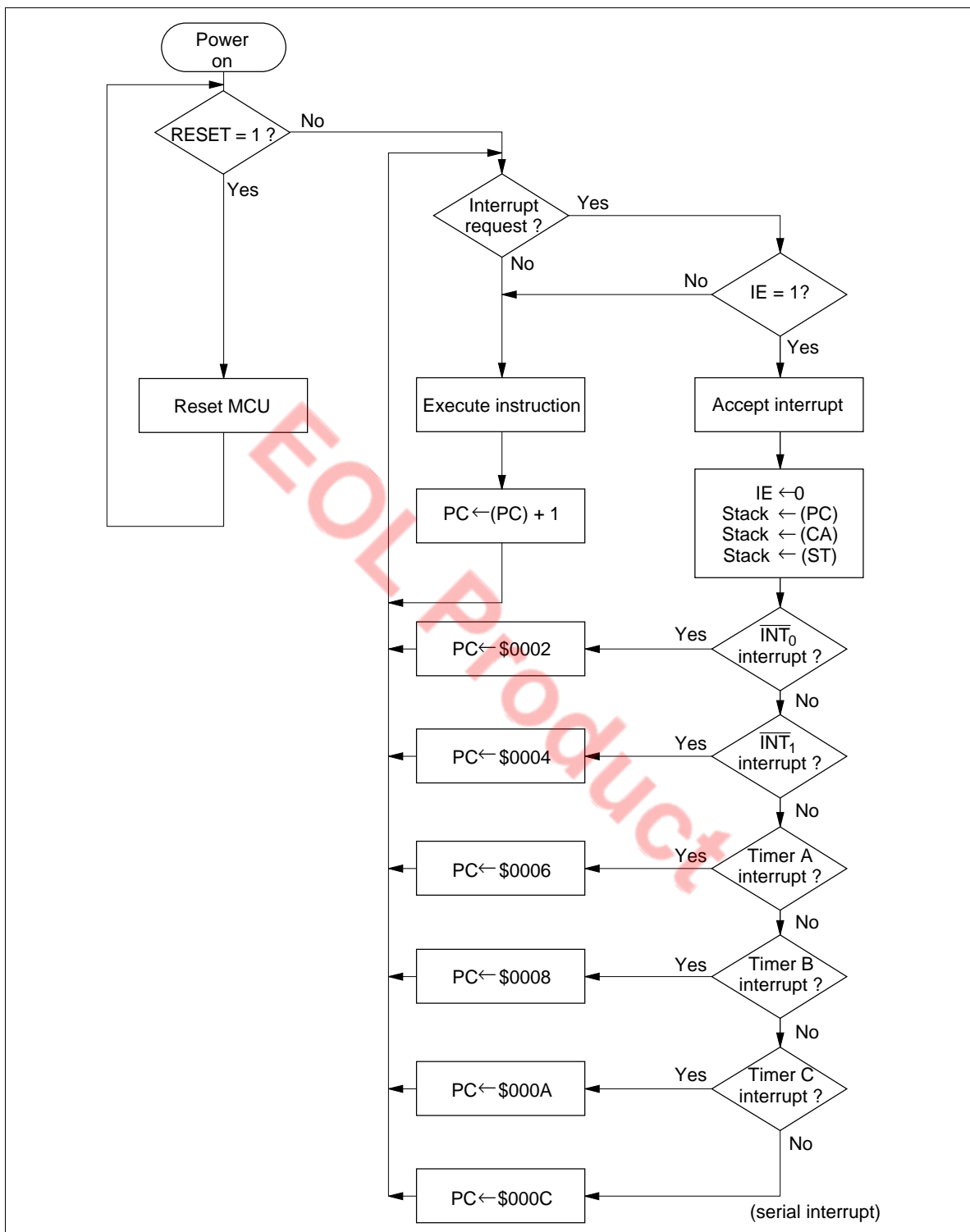

Figure 8 Interrupt Processing Flowchart

Interrupt Enable Flag (IE: \$000, Bit 0): The interrupt enable flag enables/disables interrupt requests (table 4). It is reset by an interrupt and set by the RTNI instruction.

Table 4 Interrupt Enable Flag

IE	Interrupt Enabled/Disabled
0	Disabled
1	Enabled

External Interrupts ($\overline{\text{INT}}_0$, $\overline{\text{INT}}_1$): The external interrupt request inputs ($\overline{\text{INT}}_0$, $\overline{\text{INT}}_1$) can be selected by port mode register A (PMRA: \$004).

The external interrupt request flags (IF0, IF1) are set at the falling edge of $\overline{\text{INT}}_0$ and $\overline{\text{INT}}_1$ inputs, respectively (table 5).

The $\overline{\text{INT}}_1$ input can be used as a clock signal input to timer B, in which timer B counts up at each falling edge of the $\overline{\text{INT}}_1$ input. When using $\overline{\text{INT}}_1$ as the timer B external event input, the external interrupt mask (IM1) has to be set so that the interrupt request by $\overline{\text{INT}}_1$ will not be accepted (table 6).

More than two instruction cycle times ($2t_{\text{cyc}}/2t_{\text{subcyc}}$) are needed to detect the edge of $\overline{\text{INT}}_0$ or $\overline{\text{INT}}_1$.

External Interrupt Request Flags (IF0: \$000, Bit 2; IF1: \$001, Bit 0): The external interrupt request flags (IF0, IF1) are set at the falling edge of the $\overline{\text{INT}}_0$ and $\overline{\text{INT}}_1$ inputs, respectively (table 5).

Table 5 External Interrupt Request Flags

IF0, IF1	Interrupt Request
0	No
1	Yes

External Interrupt Masks (IM0: \$000, Bit 3; IM1: \$001, Bit 1): The external interrupt masks mask the external interrupt requests (table 6).

Table 6 External Interrupt Masks

IM0, IM1	Interrupt Request
0	Enabled
1	Disabled (masked)

Timer A Interrupt Request Flag (IFTA: \$001, Bit 2): The timer A interrupt request flag is set by the overflow output of timer A (table 7).

HD404818 Series

Table 7 Timer A Interrupt Request Flag

IFTA	Interrupt Request
0	No
1	Yes

Timer A Interrupt Mask (IMTA: \$001, Bit 3): The timer A interrupt mask prevents an interrupt request from being generated by the timer A interrupt request flag (table 8).

Table 8 Timer A Interrupt Mask

IMTA	Interrupt Request
0	Enabled
1	Disabled (masked)

Timer B Interrupt Request Flag (IFTB: \$002, Bit 0): The timer B interrupt request flag is set by the overflow output of timer B (table 9).

Table 9 Timer B Interrupt Request Flag

IFTB	Interrupt Request
0	No
1	Yes

Timer B Interrupt Mask (IMTB: \$002, Bit 1): The timer B interrupt mask prevents an interrupt request from being generated by the timer B interrupt request flag (table 10).

Table 10 Timer B Interrupt Mask

IMTB	Interrupt Request
0	Enabled
1	Disabled (masked)

Timer C Interrupt Request Flag (IFTC: \$002, Bit 2): The timer C interrupt request flag is set by the overflow output of timer C (table 11).

Table 11 Timer C Interrupt Request Flag

IFTC	Interrupt Request
0	No
1	Yes

Timer C Interrupt Mask (IMTC: \$002, Bit 3): The timer C interrupt mask prevents the interrupt from being generated by the timer C interrupt request flag (table 12).

Table 12 Timer C Interrupt Mask

IMTC	Interrupt Request
0	Enabled
1	Disabled (masked)

Serial Interrupt Request Flag (IFS: \$003, Bit 0): The serial interrupt request flag is set when the octal counter counts eight transmit clock signals, or when data transfer is discontinued by resetting the octal counter (table 13).

Table 13 Serial Interrupt Request Flag

IFS	Interrupt Request
0	No
1	Yes

Serial Interrupt Mask (IMS: \$003, Bit 1): The serial interrupt mask masks the interrupt request (table 14).

Table 14 Serial Interrupt Mask

IMS	Interrupt Request
0	Enabled
1	Disabled (masked)

HD404818 Series

Operating Modes

The MCU has five operating modes that are specified by how the clock is used. The functions available in each mode are listed in table 15, and operations are shown in table 16. Transitions between operating modes are shown in figure 9.

Table 16 provides additional information for table 26.

Table 15 Functions Available in Each Operating Mode

		Mode Name				
		Active	Standby	Stop	Watch	Subactive* ⁴
Activation method		RESET cancellation, interrupt request	SBY instruction	TMA3 = 0, STOP instruction	TMA3 = 1, STOP instruction	\overline{INT}_0 or timer A interrupt request from watch mode
Status	System oscillator	OP	OP	Stopped	Stopped	Stopped
	Subsystem oscillator	OP	OP	OP * ¹	OP	OP
	Instruction execution (ϕ_{CPU})	OP	Stopped	Stopped	Stopped	OP
	Peripheral function, interrupt (ϕ_{PER})	OP	OP	Stopped	Stopped	OP
	Clock function, interrupt (ϕ_{CLK})	OP	OP	Stopped	OP * ²	OP * ²
	RAM	OP	Retained	Retained	Retained	OP
	Registers/flags	OP	Retained	Reset	Retained	OP
I/O	OP	Retained	High impedance* ³	Retained* ³	OP * ³	
Cancellation method		RESET input, STOP/SBY instruction	RESET input, interrupt request	RESET input	RESET input, \overline{INT}_0 or timer A interrupt request	RESET input, STOP/SBY instruction

Notes: OP indicates operating.

1. To reduce current dissipation, stop all oscillation in external circuits.
2. Refer to the Interrupt Frame section for details.
3. Refer to interrupt frame.
4. Subactive mode is an optional function to be specified on the function option list.
5. In the watch and subactive modes, the MCU requires a 32.768-kHz crystal oscillator.

Table 16 Operations in Low-Power Dissipation Modes

Function	Stop Mode	Watch Mode	Standby Mode	Subactive Mode* ²
CPU	Reset	Retained	Retained	OP
RAM	Retained	Retained	Retained	OP
Timer A	Reset	OP	OP	OP
Timer B	Reset	Stopped	OP	OP
Timer C	Reset	Stopped	OP	OP
Serial interface	Reset	Stopped* ³	OP	OP
LCD	Reset	OP	OP	OP
I/O	Reset* ¹	Retained	Retained	OP

Notes: OP indicates operating.

1. Output pins are at high impedance.
2. Subactive mode is an optional function to be specified on the function option list.
3. Transmission/reception is activated if a clock is input in external clock mode. (However, interrupts are stopped.)

Table 17 I/O Status in Low-Power Dissipation Modes

	Output		Input	
	Standby Mode, Watch Mode	Stop Mode	Active Mode, Subactive Mode	
D ₀ –D ₉	Retained	High impedance	Input enabled	
D ₁₀ –D ₁₃	—	—	Input enabled	
R0–R3	Retained	High impedance	Input enabled	
			System Clock (ϕ_{CPU})	
			Operating	Stopped
Non-time-base peripheral function clock (ϕ_{PER})	Operating		Active mode	Standby mode
			Subactive mode	
	Stopped	—		Watch mode (TMA3 = 1)
				Stop mode (TMA3 = 0)

HD404818 Series

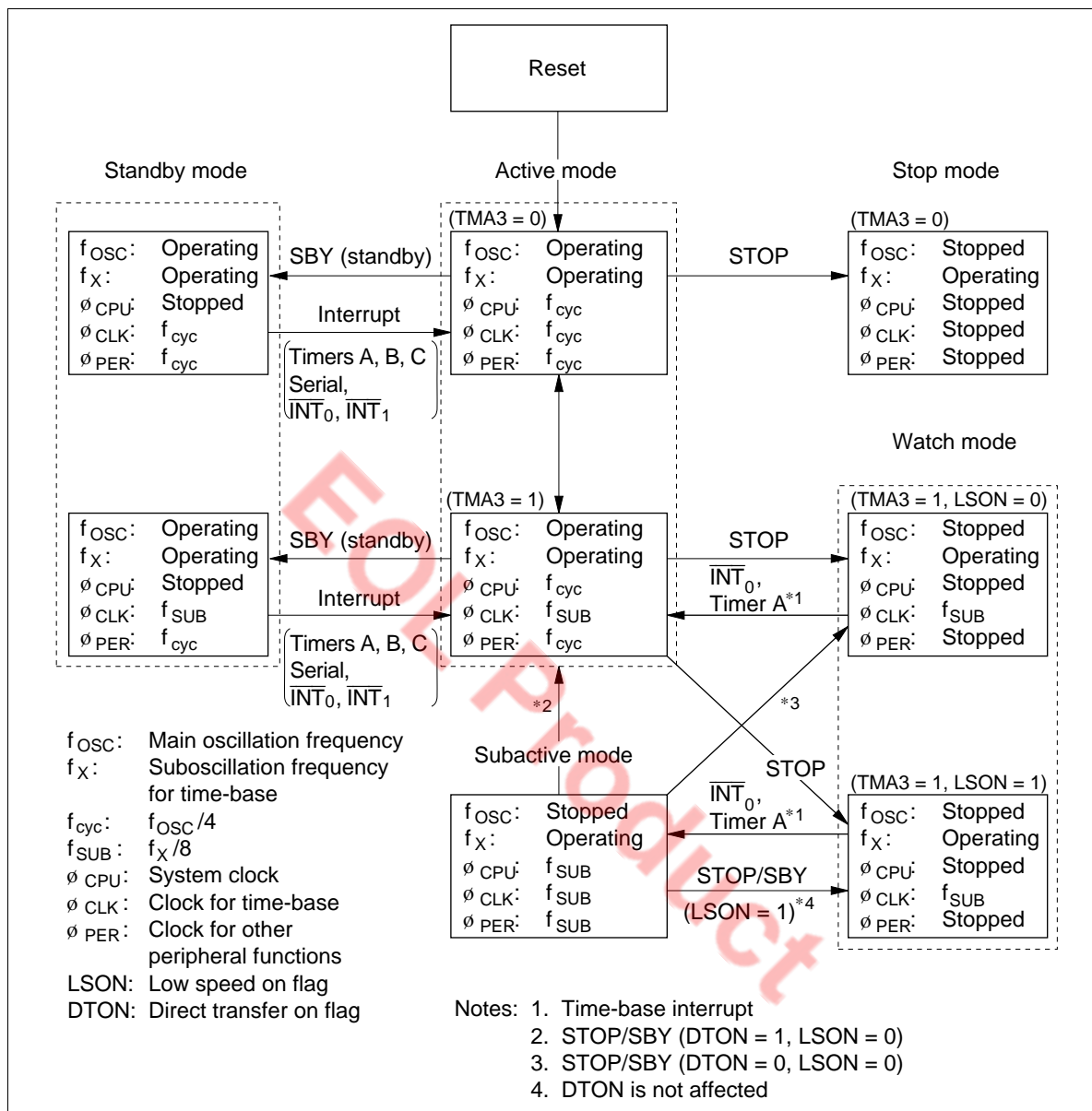

Figure 9 MCU Status Transitions

Active Mode: The MCU operates according to the clock generated by the system oscillators OSC_1 and OSC_2 .

Standby Mode: The MCU enters standby mode when the SBY instruction is executed from active mode. In this mode, the oscillators, interrupts, timer/counters, and serial interface continue to operate, but all instruction execution-related clocks stop. The stopping of these clocks stops the CPU, retaining all RAM and register contents and maintaining the current I/O pin status.

Standby mode is terminated by a RESET input or an interrupt request. If it is terminated by a RESET input, the MCU is reset as well. After an interrupt request, the MCU enters active mode and resumes, executing

the next instruction after the SBY instruction. If the interrupt enable flag is 1, that interrupt is then processed; if it is 0, the interrupt request is left pending and normal instruction execution continues. A flowchart of operation in standby mode is shown in figure 10.

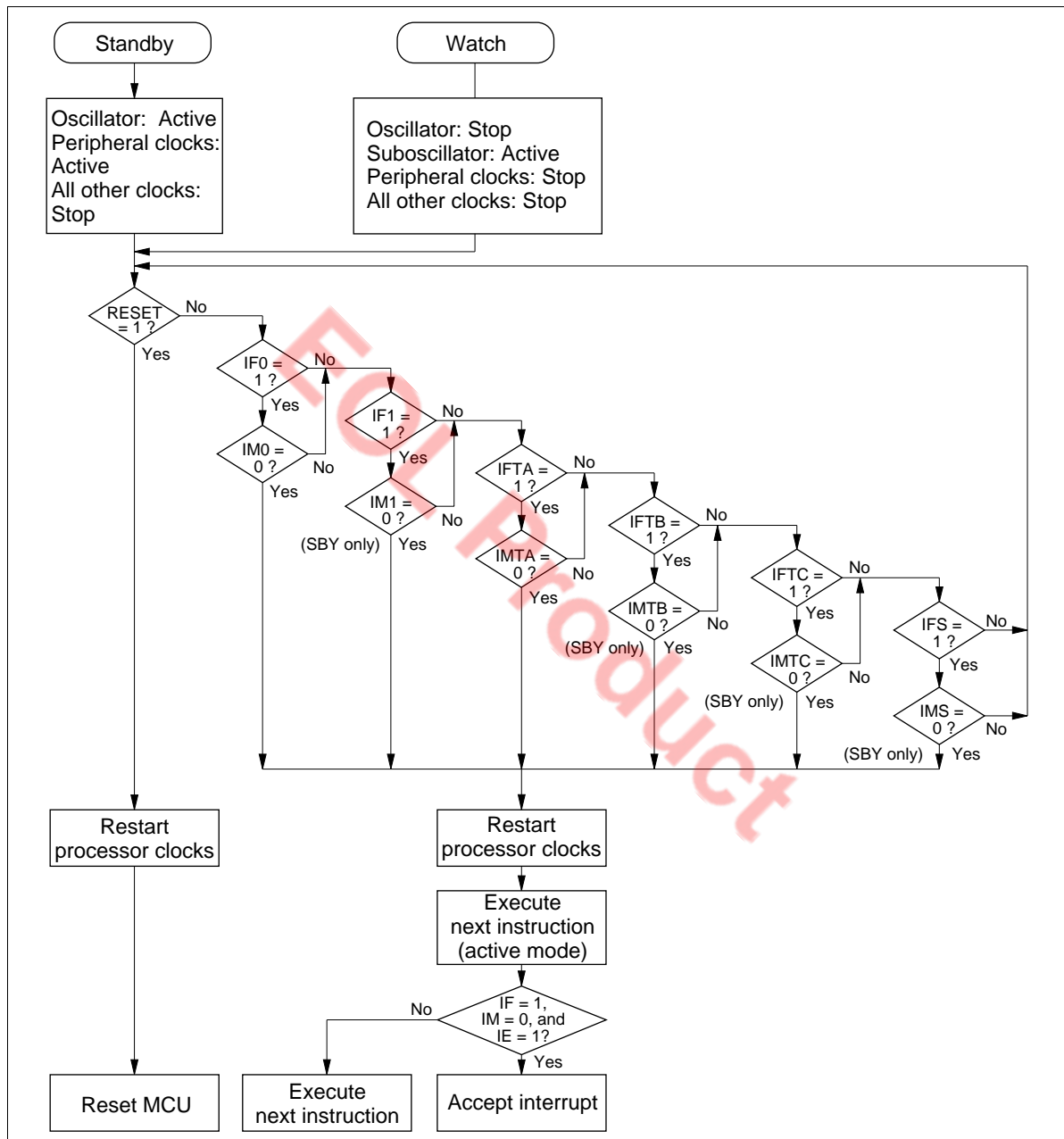

Figure 10 MCU Operating Flowchart of Watch and Standby Modes

HD404818 Series

Stop Mode: The MCU enters stop mode if the STOP instruction is executed in active mode when TMA3 = 0. In this mode, the system oscillator stops, which stops all MCU functions as well.

Stop mode is terminated by a RESET input as shown in figure 11. RESET must be high for at least one t_{RC} to stabilize oscillation (refer to the AC Characteristics section). When the MCU restarts after stop mode is cancelled, all RAM contents are retained, but the accuracy of the contents of the accumulator, B register, W register, X/SPX register, Y/SPY register, carry flag, and serial data register cannot be guaranteed.

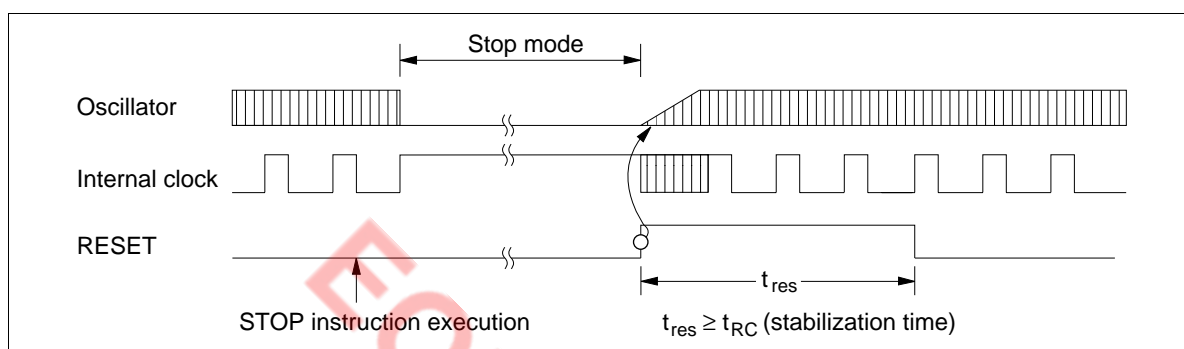

Figure 11 Timing of Stop Mode Cancellation

Watch Mode: The MCU enters watch mode if the STOP instruction is executed in active mode when TMA3 = 1, or if the STOP or SBY instruction is executed in subactive mode.

Watch mode is terminated by a RESET input or a timer-A/ \overline{INT}_0 interrupt request. For details on RESET input, refer to the Stop Mode section. When terminated by a timer-A/ \overline{INT}_0 interrupt request, the MCU enters active mode if LSON is 0, or subactive mode if LSON is 1. After an interrupt request is generated, the time required to enter active mode is t_{RC} for a timer A interrupt, and T_X (where $T + t_{RC} \leq T_X \leq 2T + t_{RC}$) for an \overline{INT}_0 interrupt, as shown in figure 12.

Operation during mode transition is the same as that at standby mode cancellation (figure 10).

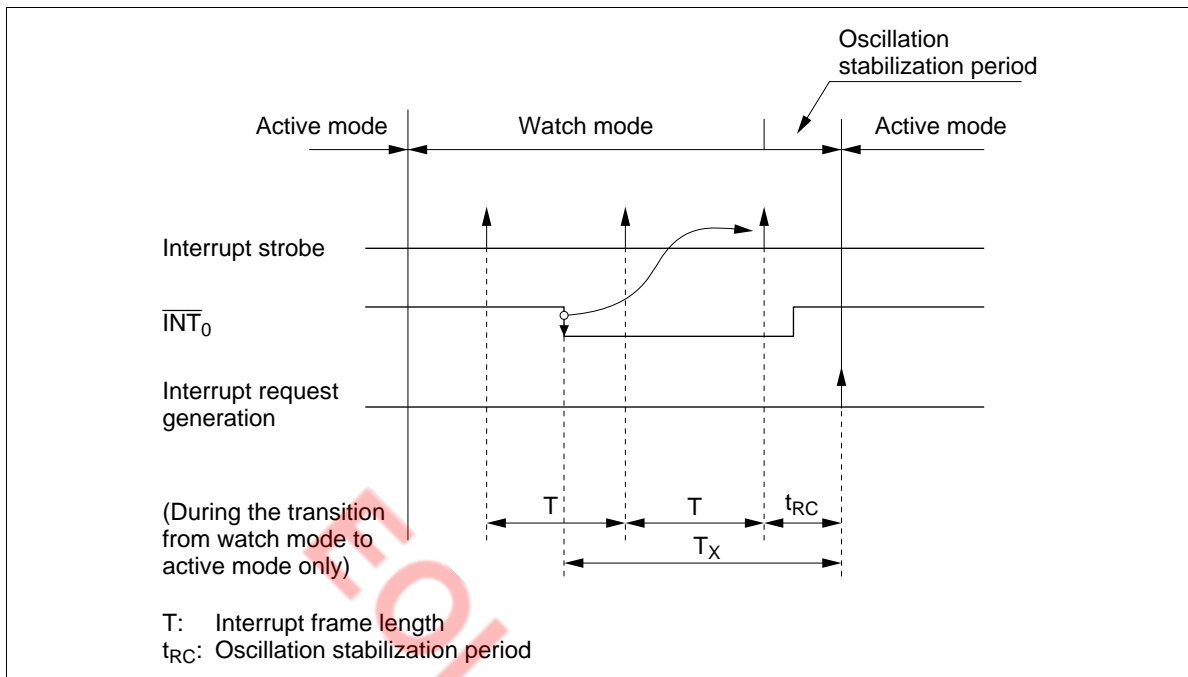

Figure 12 Interrupt Frame

Subactive Mode: The CPU operates with a clock generated by the X1 and X2 oscillation circuits. Functions that can operate in subactive mode are listed in table 16. When the STOP or SBY instruction is executed in subactive mode, the MCU enters either watch or active mode, depending on the statuses of LSON and DTON. The DTON flag can only be set in subactive mode; it is automatically reset after a transition to active mode.

Subactive mode is an optional function that the user must specify on the function option list.

Interrupt Frame: In watch and subactive modes, ϕ_{CLK} is supplied for timer A and the \overline{INT}_0 circuit. Prescaler W and timer A operate as time bases to generate interrupt frame timing. Three interrupt frame cycles (T) can be selected by the settings of the miscellaneous register, as shown in figure 13.

In watch and subactive modes, timer A and \overline{INT}_0 interrupts are generated in synchronism with the interrupt frame. An interrupt request is generated at an interrupt strobe, except when the MCU enters active mode from watch mode. The \overline{INT}_0 falling edge is acknowledged regardless of the interrupt frame, but an interrupt is executed simultaneously with the second interrupt strobe. Timer A generates an overflow and interrupt request at an interrupt strobe.

HD404818 Series

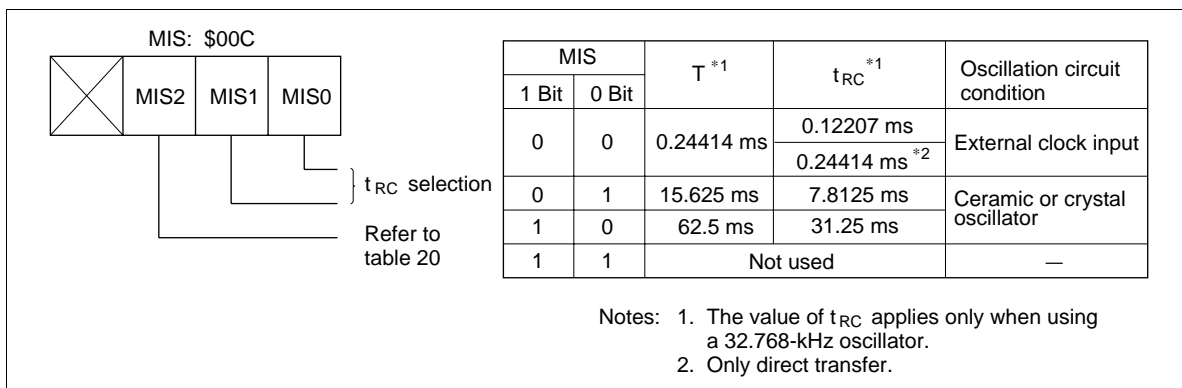

Figure 13 Miscellaneous Register

Direct Transfer: By controlling the DTON, the MCU can be placed directly from subactive to active mode. The detailed procedure is as follows:

- Set the DTON flag in subactive mode while LSON = 0.
- Execute the STOP or SBY instruction.
- After the oscillation stabilization time (a fixed value), the MCU will move automatically from subactive to active mode.

Note that DTON (\$020, bit 3) is valid only in subactive mode. When the MCU is in active mode, this flag is always at reset.

The transition time (t_D) from subactive to active mode is $t_{RC} < t_D < T + t_{RC}$.

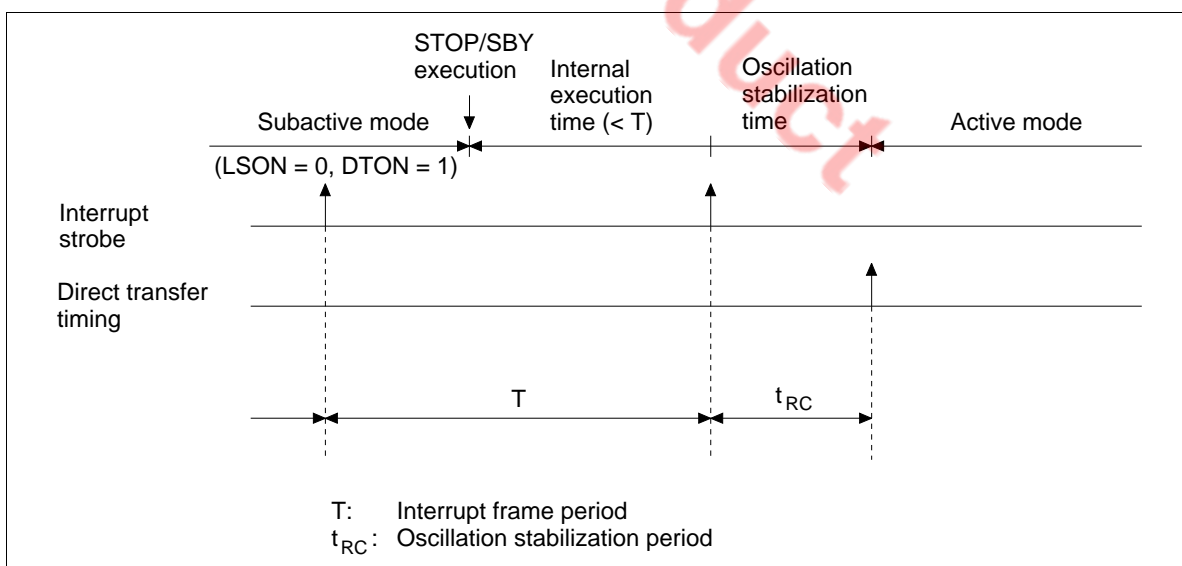

Figure 14 Direct Transfer Timing

MCU Operating Sequence: The MCU operates in the sequence shown in figures 15 to 17. It is reset by an asynchronous RESET input, regardless of its state.

The low-power mode operation sequence is shown in figure 17. With the IE flag cleared and an interrupt flag set together with its interrupt mask cleared, if a STOP/SBY instruction is executed, the instruction is cancelled (regarded as a NOP) and the following instruction is executed. Before executing a STOP/SBY instruction, make sure all interrupt flags are cleared or all interrupts are masked.

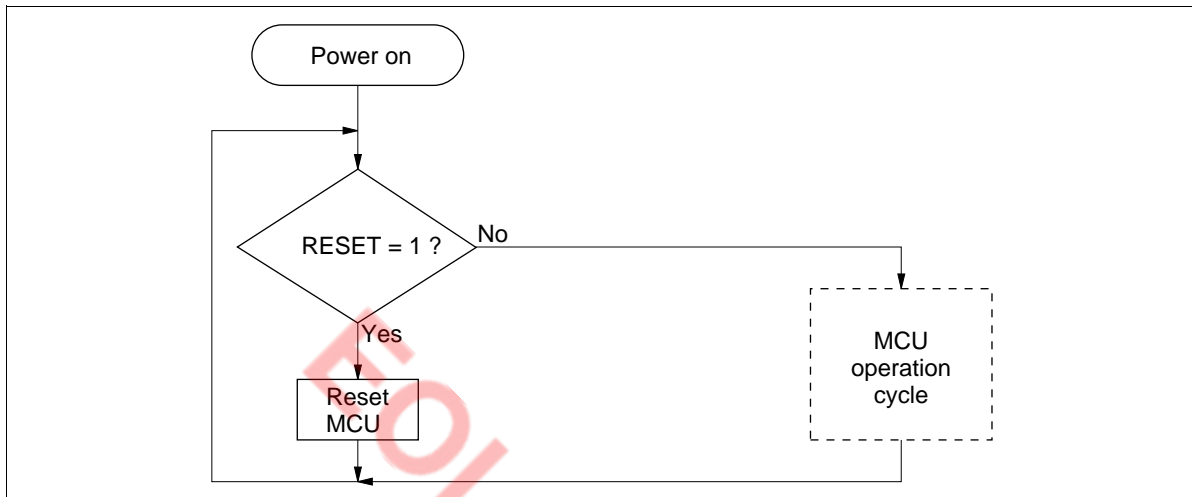

Figure 15 MCU Operating Sequence (power on)

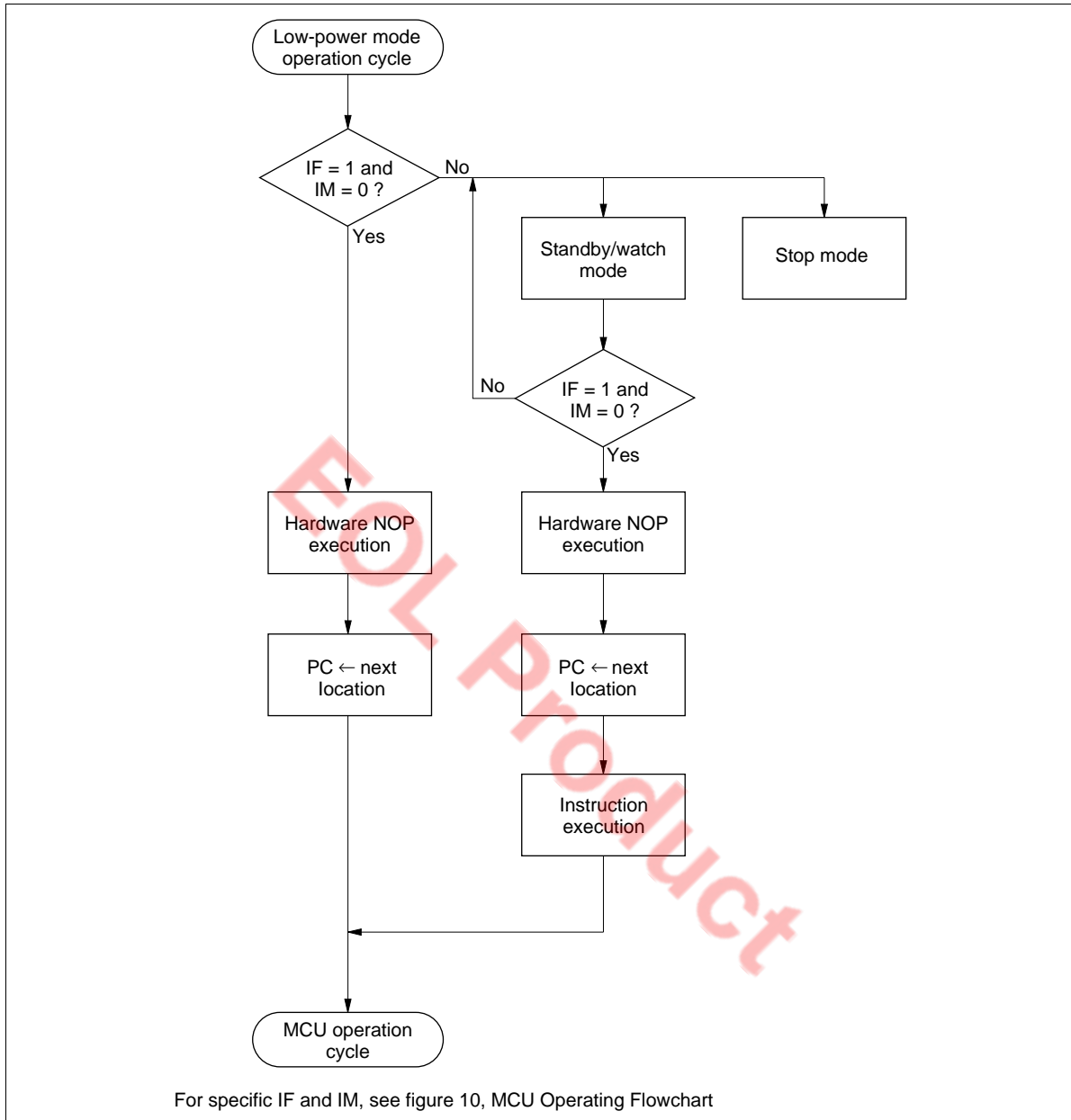

Figure 17 MCU Operating Sequence (low-power mode operation)

Notes on Use:

- In subactive mode, a timer A interrupt request or an external interrupt request (\overline{INT}_0) occurs in synchronism with an interrupt strobe.
If the STOP or SBY instruction is executed at the same time with an interrupt strobe, these interrupt requests will be cancelled and the corresponding interrupt request flags (IFTA, IF0) will not be set.
In subactive mode, do not use the STOP or SBY instruction at the time of an interrupt strobe.

HD404818 Series

- When the MCU is in watch mode or subactive mode, if the high level period before the falling edge of $\overline{\text{INT}}_0$ is shorter than the interrupt frame, $\overline{\text{INT}}_0$ is not be detected. Also, if the low level period after the falling edge of $\overline{\text{INT}}_0$ is shorter than the interrupt frame, $\overline{\text{INT}}_0$ is not be detected.

Edge detection is shown in figure 18. The level of the $\overline{\text{INT}}_0$ signal is sampled by a sampling clock. When this sampled value changes to low from high, a falling edge is detected.

In figure 19, the level of the $\overline{\text{INT}}_0$ signal is sampled by an interrupt frame. In (a) the sampled value is low at point A, and also low at point B. Therefore, a falling edge is not detected. In (b), the sampled value is high at point A, and also high at point B. A falling edge is not detected in this case either.

When the MCU is in watch mode or subactive mode, keep the high level and low level period of $\overline{\text{INT}}_0$ longer than the interrupt frame.

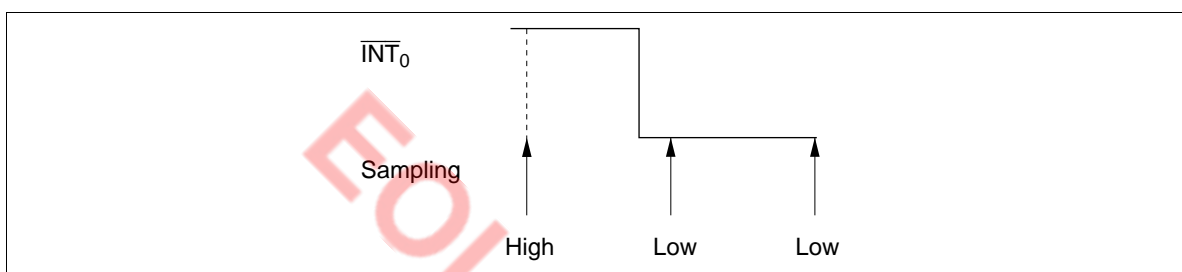

Figure 18 Edge Detection

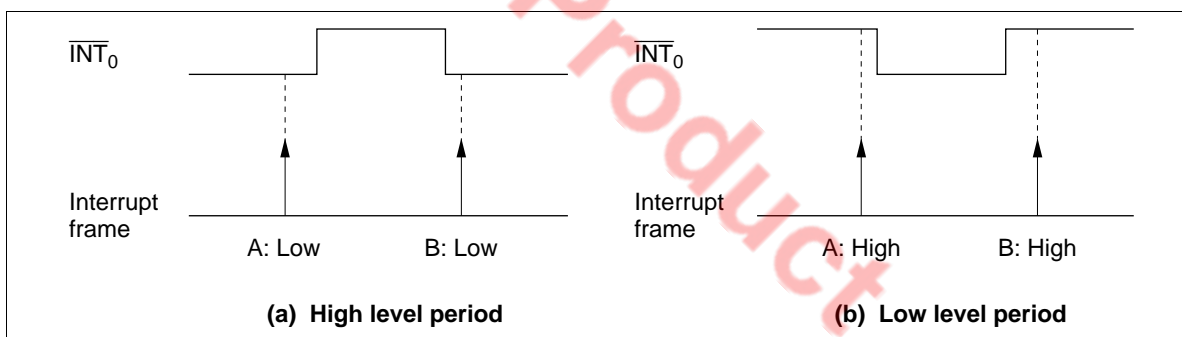

Figure 19 Sampling Example

Internal Oscillator Circuit

Figure 20 shows the block diagram of the internal oscillator circuit. A ceramic oscillator can be connected to OSC₁ and OSC₂. A 32.768-kHz crystal oscillator can be connected to X1 and X2. External clock operation is available for the system oscillator.

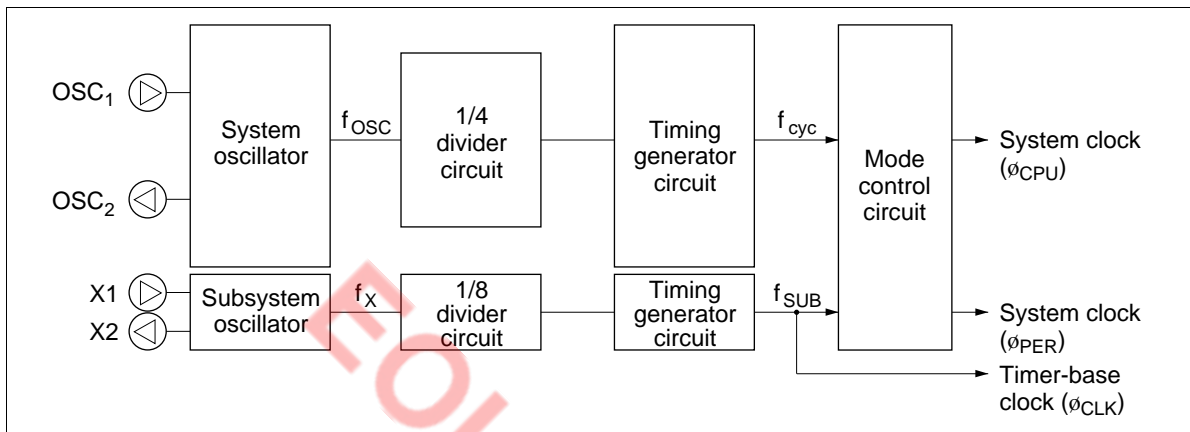

Figure 20 Internal Oscillator Circuit

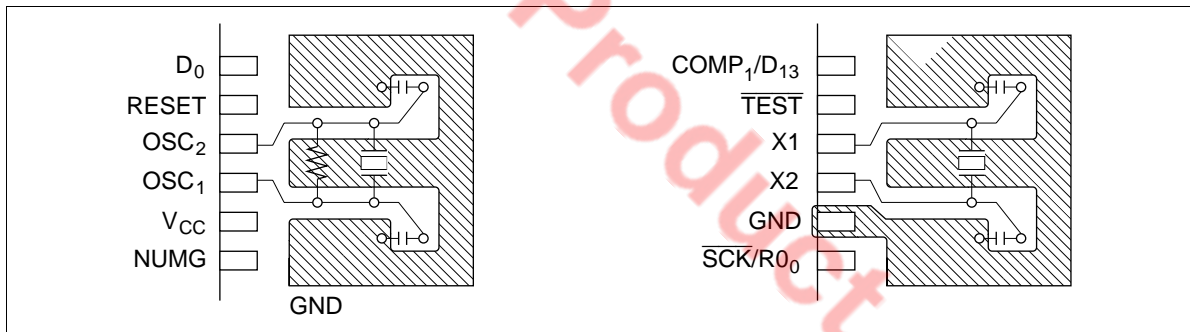

Figure 21 Layout of Crystal and Ceramic Oscillators

HD404818 Series

Table 18 Examples of Oscillator Circuits

	Circuit Configuration	Circuit Constants
External clock operation		
Ceramic oscillator		<p>HD404812, HD404814, HD404816, HD404818, HD4074818 Ceramic oscillator: CSA4.00MG (Murata) $R_f = 1\text{M}\Omega \pm 20\%$ $C_1 = C_2 = 30\text{ pF} \pm 20\%$</p>
Crystal oscillator		<p>HD404812, HD404814, HD404816, HD404818, HD4074818 C_1: 10 to 22 pF $\pm 20\%$ C_2: 10 to 22 pF $\pm 20\%$ $R_f = 1\text{ M}\Omega \pm 20\%$ Crystal: Equivalent to circuit shown at bottom left. C_0: 7 pF max. R_s: 100 Ω max</p>

Table 18 Examples of Oscillator Circuits (cont)

Circuit Configuration	Circuit Constants
<p>Crystal oscillator</p> 	<p>Crystal: 32.768 kHz: MX38T (Nippon Denpa Kogyo) $C_1 = 20 \text{ pF} \pm 20\%$ $C_2 = 20 \text{ pF} \pm 20\%$ $R_S = 14 \text{ k}\Omega$ $C_0 = 1.5 \text{ pF}$</p>

- Notes: 1. The circuit parameters above are recommended by the crystal or ceramic oscillator manufacturer. The circuit parameters are affected by the crystal or ceramic oscillator and floating capacitance when designing the board. When using the oscillator, consult with the crystal or ceramic oscillator manufacturer to determine the circuit parameters.
2. Writing among OSC₁ and OSC₂ or X1 and X2, and other elements should be as short as possible, and should not cross other wires. Refer to figure 21.
3. When the 32.768-kHz crystal oscillator is not used, pin X1 must be fixed to V_{cc} and pin X2 must be left open.

HD404818 Series

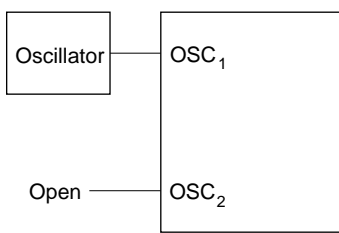
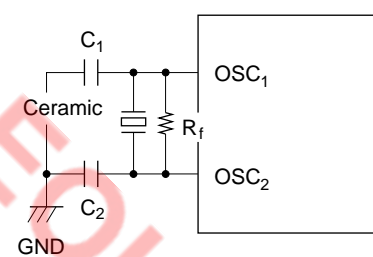
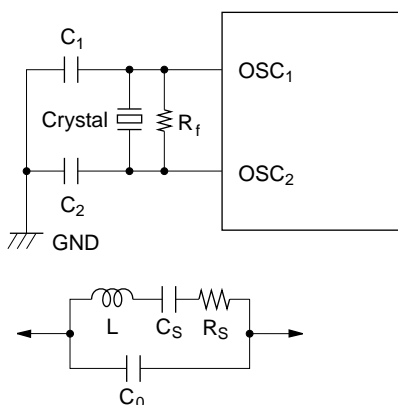
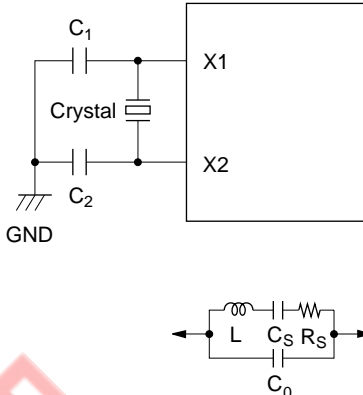
Input/Output

The MCU provides 26 I/O pins and 4 input-only pins including 10 high-current pins (15 mA max.). Twenty-six I/O pins contain programmable pull-up MOS. When each I/O pin is used as an input, the data control register (DCR) controls the output buffer. Table 19 shows the I/O pin circuit types.

The configuration of the I/O buffers is shown in table 19.

EOL Product

Table 19 I/O Pin Circuit Types

I/O Pins	Circuit	Pin Name
I/O common pins (with pull-up MOS)		D_0 - D_9 $R0_0$ - $R0_3$ $R1_0$ - $R1_3$ $R2_0$ - $R2_3$ $R3_0$ - $R3_3$
		\overline{SCK}
Output pins (with pull-up MOS)		SO $TIMO$
Input pins		\overline{INT}_0 \overline{INT}_1 SI
		D_{10} D_{11}/V_{Cref}
		$D_{12}/COMP_0$ $D_{13}/COMP_1$ (Multiplexed with analog inputs)

Note: For RO_2/SO , refer to table 20, note 3.

HD404818 Series

D Port: Consists of ten 1-bit I/O ports and four input ports. Pins D_0 to D_9 are high-current I/O pins (15 mA max.). The sum of the current for all D-port pins is up to 100 mA. D port can be set/reset by the SED/RED and SEDD/REDD instructions, and can be tested by the TD/TDD instruction. Output data is stored in the port data register. The output buffer for port D can be turned on/off by the D-port data control registers (DCRB, DCRC, DCRD). The DCR is located in the memory address area. Pins D_{10} to D_{13} are input-only pins.

Two operation modes are available for pins D_{12} and D_{13} : digital input mode and analog input mode. The operation modes can be selected by port mode register B (PMRB; bits 1, 0). In the digital input mode, these pins can be used as input with the same characteristics as other I/O pins. In the analog input mode, users can read the result of the comparison between the reference voltage as input data. The reference voltage is input through $D_{11}/V_{C_{ref}}$.

R Port: Consists of four 4-bit I/O ports and can receive/transmit data by the LAR/LRA and LBR/LRB instructions. Output data is stored in the port data register (PDR) of each pin.

The output buffers of the R ports can be turned on/off by the R-port data control registers (DCR0–DCR3).

The DCR is located in the memory address area.

Pins $R0_0$, $R0_1$, and $R0_2$ are multiplexed with \overline{SCK} , SI, and SO, respectively.

Pins $R3_1$, $R3_2$, and $R3_3$ are multiplexed with TIMO, \overline{INT}_0 , and \overline{INT}_1 , respectively. Refer to figure 23.

Pull-Up MOS Transfer Control: All I/O ports, except for pins D_{10} – D_{13} , contain programmable pull-up MOS.

Bit 3 of port mode register B (PMRB3) controls the activation of all pull-up MOS simultaneously. Pull-up MOS is controlled by the port data register (PDR) of each pin. Therefore, each bit of pull-up MOS can be individually turned on or off. Refer to table 20.

The on/off status of each transistor and the peripheral function mode of each pin can be set independently.

Unused I/O Pins: If unused pins are left floating, the LSI may malfunction because of noise. The I/O pins should be fixed as follows to prevent this: pull-up to V_{CC} through internal pull-up MOS, or pull-up to V_{CC} through a resistor of approximately 100 k Ω .

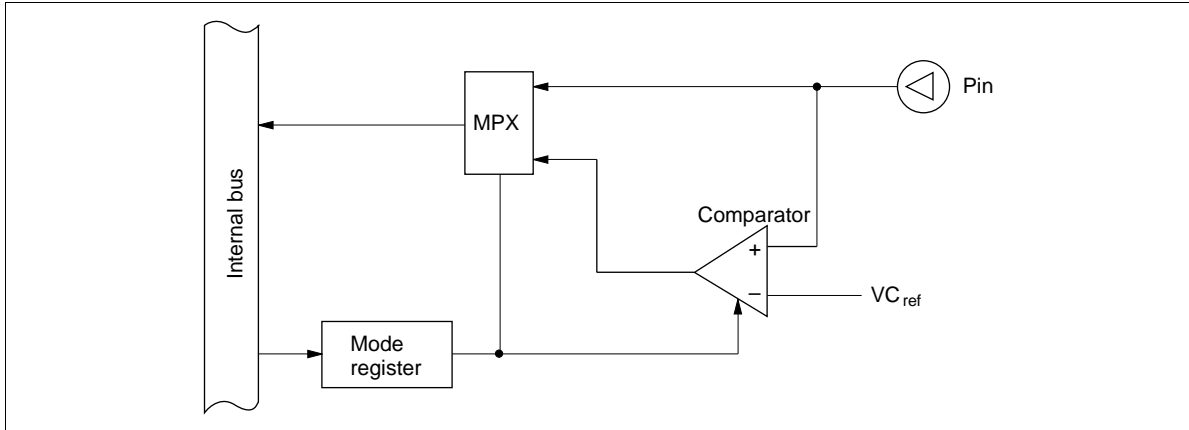

Figure 22 Configuration of D12 and D13

EOL Product

HD404818 Series

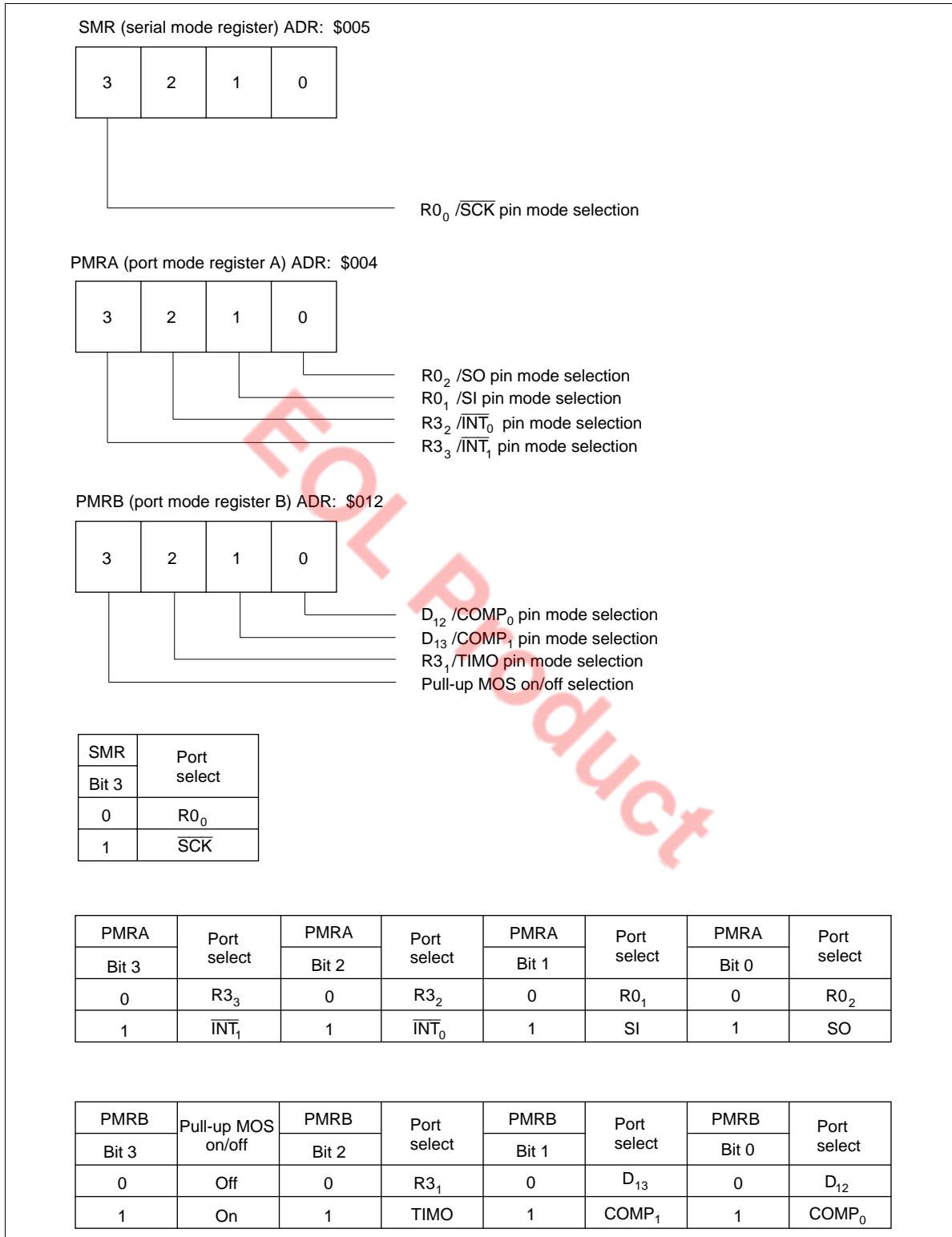

Figure 23 I/O Select Mode Registers

Table 20 Input/Output by Program Control

PMRB Bit 3	0				1			
DCR	0	1	0	1	0	1	0	1
PDR	0	1	0	1	0	1	0	1
PMOS (A)	—	—	—	On	—	—	—	On
NMOS (B)	—	—	On	—	—	—	On	—
Pull-up MOS	—	—	—	—	—	On	—	On

Notes: — indicates off status.

- Combine the values of the above mode registers (PMRB3, DCR, and PDR) to select the input/output for PMOS (A), NMOS (B), and the pull-up MOS, individually. The DCR and PDR control each pin. Also, PMRB3 controls the on/off of all pull-up MOSs.
- The second bit of the miscellaneous register (MIS2) controls R0₂/SO. When MIS2 is 1, PMOS (A) is off.

MIS2	R0 ₂ /SO PMOS (A)
0	On
1	Off

- Each bit of DCR corresponds to each port as follows:

DCR	Bit 3	Bit 2	Bit 1	Bit 0
DCR0	R0 ₃	R0 ₂	R0 ₁	R0 ₀
DCR1	R1 ₃	R1 ₂	R1 ₁	R1 ₀
DCR2	R2 ₃	R2 ₂	R2 ₁	R2 ₂
DCR3	R3 ₃	R3 ₂	R3 ₁	R3 ₀
DCRB	D ₃	D ₂	D ₁	D ₀
DCRC	D ₇	D ₆	D ₅	D ₄
DCRD	—	—	D ₉	D ₈

Timers

The MCU provides prescalers S and W (each with a different input clock source), and three timer/ counters (timers A, B, and C). Figures 25, 26 and 27 show their diagrams.

Prescaler S: The input to prescaler S is the system clock signal. The prescaler is initialized to \$000 by MCU reset, and starts to count up with the system clock signal as soon as the RESET input goes low. The prescaler keeps counting up except at MCU reset and in the stop and watch modes. The prescaler provides input clock signals to timers A to C and the transmit clock of the serial interface. They can be selected by timer mode registers A (TMA), B (TMB), C (TMC), and the serial mode register (SMR), respectively.

Prescaler W: The input to prescaler W is a clock which divides the X1 input clock by 8. The output of prescaler W is available as an input clock for timer A by controlling timer mode register A (TMA).

Timer A Operation: After timer A is initialized to \$00 by MCU reset, it counts up at every clock input signal. When the next clock signal is applied after timer A has counted up to \$FF, timer A is set to \$00 again, and an overflow output is generated. This sets the timer A interrupt request flag (IFTA: \$001, bit 2) to 1. Therefore, timer A can function as an interval timer periodically generating overflow output at every 256th clock signal input (figure 25).

To use timer A as a watch time base, set TMA3 to 1. Timer counter A receives prescaler W output, and timer A generates interrupts with accurate timing (reference clock = 32-kHz crystal oscillator). When using timer A as a watch time base, prescaler W and the timer counter can be initialized to \$0 by setting timer mode register A.

The clock input signals to timer A are selected by timer mode register A (TMA: \$008).

HD404818 Series

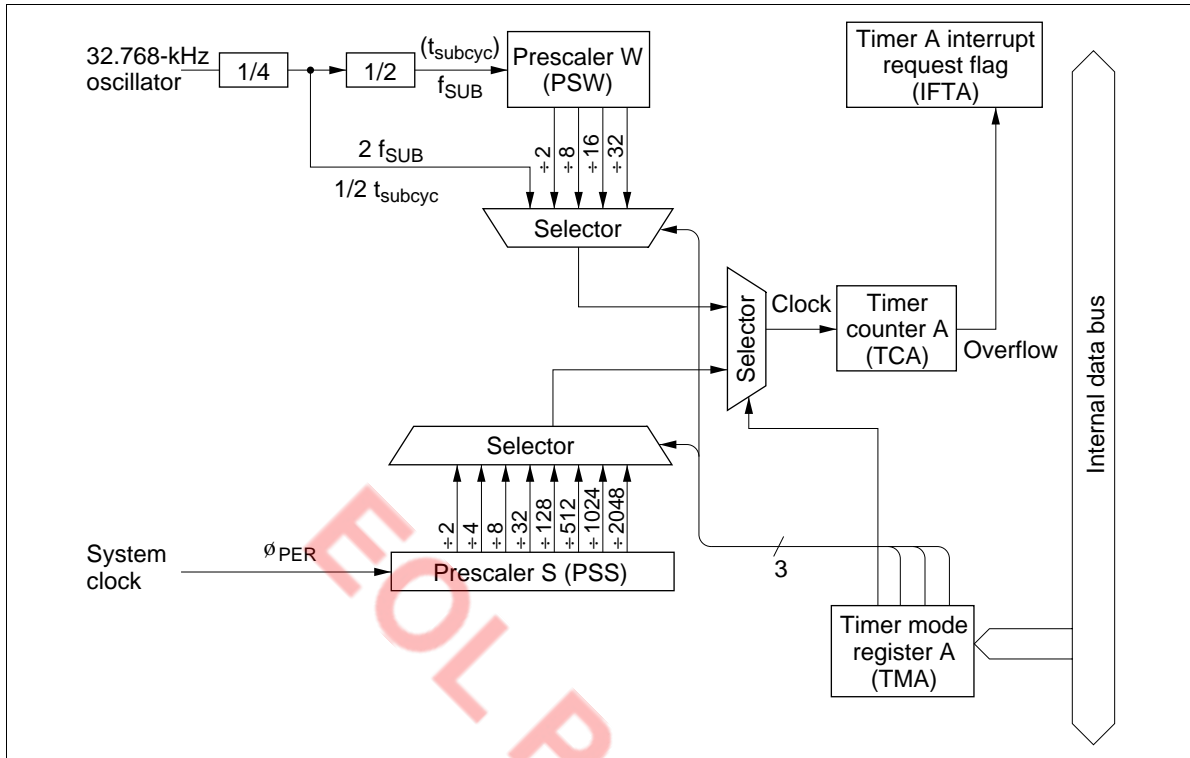

Figure 25 Timer A Block Diagram

Timer B Operation: Timer mode register B (TMB: \$009) selects the auto-reload function, input clock source, and prescaler divide ratio for timer B. When an external event input is used as an input clock signal to timer B, select $R3/\overline{INT}_1$ as \overline{INT}_1 by port mode register A (PMRA: \$004) to prevent an external interrupt request from occurring (figure 26)

Timer B is initialized according to the data written into timer load register B by software. Timer B counts up at every clock input signal. When the next clock signal is applied to timer B after it is set to \$FF, it will generate an overflow output. In this case, if the auto-reload function is selected, timer B is initialized according to the value of timer load register B. If it is not selected, timer B goes to \$00. The timer B interrupt request flag (IFTB: \$002, bit 0) will be set as this overflow is output.

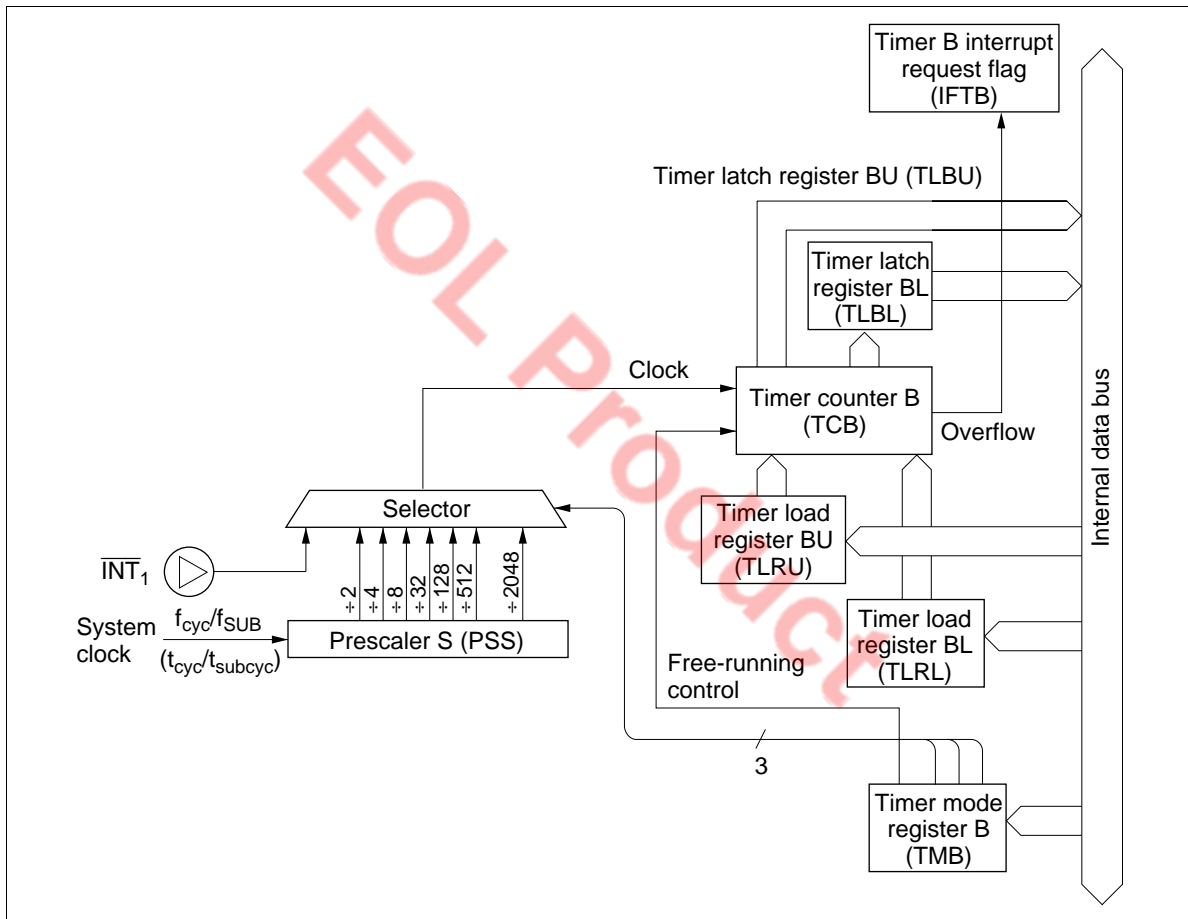

Figure 26 Timer B Block Diagram

Timer C Operation: Timer mode register C (TMC: \$00D) selects the auto-reload function and the prescaler divide ratio for timer C.

Timer C is initialized according to the data written into timer load register C by software. Timer C counts up at every clock input signal. When the next clock signal is applied to timer C after it is set to \$FF, it will generate an overflow output. In this case, if the auto-reload function is selected, timer C is initialized

HD404818 Series

according to the value of timer load register C. If it is not selected, timer C goes to \$00. The timer C interrupt request flag (IFTC: \$002, bit 2) will be set as this overflow is output.

Timer C is also available as a watchdog timer for detecting runaway programs. MCU reset occurs when the watchdog on flag (WDON) is 1 and the counter overflow output is generated by a runaway program. If timer C stops, the watchdog timer function also stops. In the standby mode, this function is enabled.

Timer C provides a variable duty-cycle pulse output function (PWM). The output waveform differs depending on the contents of the timer mode register and timer load register C (figure 28). When selecting the pulse output function, set R3₁/TIMO to TIMO by controlling port mode register B.

When timer C stops, this functions also stops.

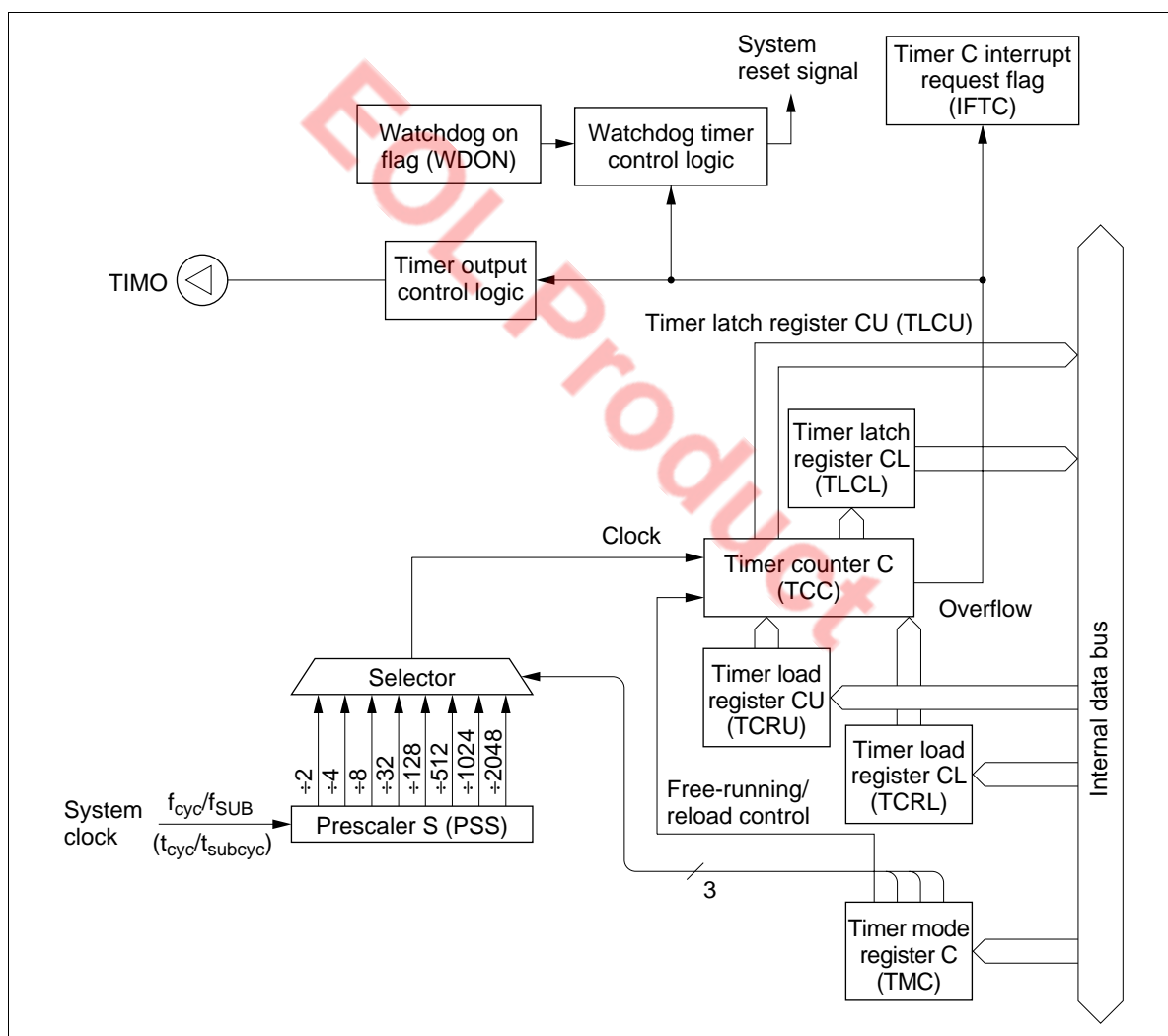
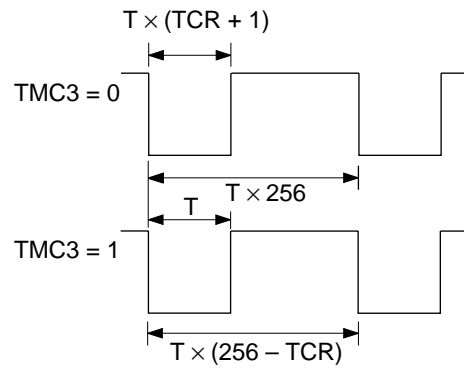

Figure 27 Timer C Block Diagram



T: Input clock period to counter (see table 23)
 TCR: The value of the timer load register

Note: When TCR = \$FF, this waveform is always fixed low.

Figure 28 Variable Duty-Cycle Pulse Output Waveform

HD404818 Series

Registers for Timers

Timer Mode Register A (TMA: \$008): Timer mode register A is a 4-bit write-only register which controls the timer A operation as table 21 shows. Timer mode register A is initialized to \$0 at MCU reset.

Timer Mode Register B (TMB: \$009): Timer mode register B (TMB) is a 4-bit write-only register which selects the auto-reload function, the prescaler divide ratio, and the source of the clock input signal, as shown in table 22. Timer mode register B is initialized to \$0 by MCU reset.

The data of timer B changes at the second instruction cycle of a write instruction. Initialization of timer B by writing data into timer load register B should be performed after the contents of TMB are changed.

Table 21 Timer Mode Register A

TMA				Source Prescaler, Input Clock Period, Operating Mode	
Bit 3	Bit 2	Bit 1	Bit 0		
0	0	0	0	PSS, 2048 t_{cyc}	Timer A mode
			1	PSS, 1024 t_{cyc}	
		1	0	PSS, 512 t_{cyc}	
			1	PSS, 128 t_{cyc}	
	1	0	0	PSS, 32 t_{cyc}	
			1	PSS, 8 t_{cyc}	
		1	0	PSS, 4 t_{cyc}	
			1	PSS, 2 t_{cyc}	
1	0	0	0	PSW, 32 t_{subcyc}	Time-base mode
			1	PSW, 16 t_{subcyc}	
		1	0	PSW, 8 t_{subcyc}	
			1	PSW, 2 t_{subcyc}	
	1	0	0	PSW, 1/2 t_{subcyc}	
			1	Do not use	
		1	0	PSW, TCA reset	
			1		

- Notes:
- $t_{subcyc} = 244.14 \mu\text{s}$ (when a 32.768-kHz crystal oscillator is used)
 - Timer counter overflow output period (s) = input clock period (s) \times 256
 - If PSW or TCA reset is selected while the LCD is operating, LCD operation halts (power switch goes off).
When the LCD is connected for display, the PSW and TCA reset periods must be set in the program to the minimum.
 - In time base mode, the timer counter overflow output cycle must be greater than half of the interrupt frame period ($T/2 = t_{RC}$).
If 1/2 t_{subcyc} is selected, t_{RC} must be 7.8125 ms ((MIS1, MIS0) = (0, 1), see figure 13).

5. The division ratio must not be modified during time base mode operation, otherwise an overflow cycle error will occur.

Timer Mode Register C (TMC: \$00D): Timer mode register C is a 4-bit write-only register which selects the auto-reload function, input clock source, and prescaler divide ratio, as table 23 shows. Timer mode register C is initialized to \$0 at MCU reset.

The contents of timer mode register C will change in the second instruction cycle after a write instruction to TMC. Therefore, it is required to initialize timer C after the contents of timer mode register C have been changed completely.

Timer B (TCBL: \$00A, TCBU: \$00B, TLRL: \$00A, TLRU: \$00B): Timer B consists of an 8-bit write-only timer load register, and an 8-bit read-only timer counter. Each of them has low-order digits (TCBL: \$00A, TLRL: \$00A) and high-order digits (TCBU: \$00B, TLRU: \$00B). (Refer to figure 26.)

Timer counter B can be initialized by writing data into timer load register B. In this case, write the low-order digits first, and then the high-order digits. The timer counter is initialized when the high-order digit is written. The timer load register is initialized to \$00 by MCU reset.

The counter value of timer B can be obtained by reading timer counter B. In this case, read the high-order digits first, and then the low-order digits. The count value of the low-order digit is obtained when the high-order digit is read.

Timer C (TCCL: \$00E, TCCU: \$00F, TCRL: \$00E, TCRU: \$00F): Timer C consists of the 8-bit write-only timer load register and the 8-bit read-only timer counter. These individually consist of low-order digits (TCCL: \$00E, TCRL: \$00E) and high-order digits (TCCU: \$00F, TCRU: \$00F). The operation mode of timer C is the same as that of timer B.

Table 22 Timer Mode Register B

TMB3	Auto-Reload Function
0	No
1	Yes

TMB2	TMB1	TMB0	Prescaler Divide Ratio, Clock Input Source
0	0	0	÷ 2048
0	0	1	÷ 512
0	1	0	÷ 128
0	1	1	÷ 32
1	0	0	÷ 8
1	0	1	÷ 4
1	1	0	÷ 2
1	1	1	INT ₁ (external event input)

HD404818 Series

Table 23 Timer Mode Register C

TMC3	Auto-Reload Function
0	No
1	Yes

TMC2	TMC1	TMC0	Prescaler Divide Ratio, Clock Input Source
0	0	0	÷ 2048
0	0	1	÷ 1024
0	1	0	÷ 512
0	1	1	÷ 128
1	0	0	÷ 32
1	0	1	÷ 8
1	1	0	÷ 4
1	1	1	÷ 2

Notes on Use

When using the timer output as variable duty-cycle pulse (PWM) output, note the following point. From the update of the timer write register until the occurrence of the overflow interrupt, the PWM output differs from the period and duty settings, as shown in table 24. The PWM output should therefore not be used until after the overflow interrupt following the update of the timer write register. After the overflow, the PWM output will have the set period and duty cycle.

Table 24 PWM Output Following Update of Timer load Register

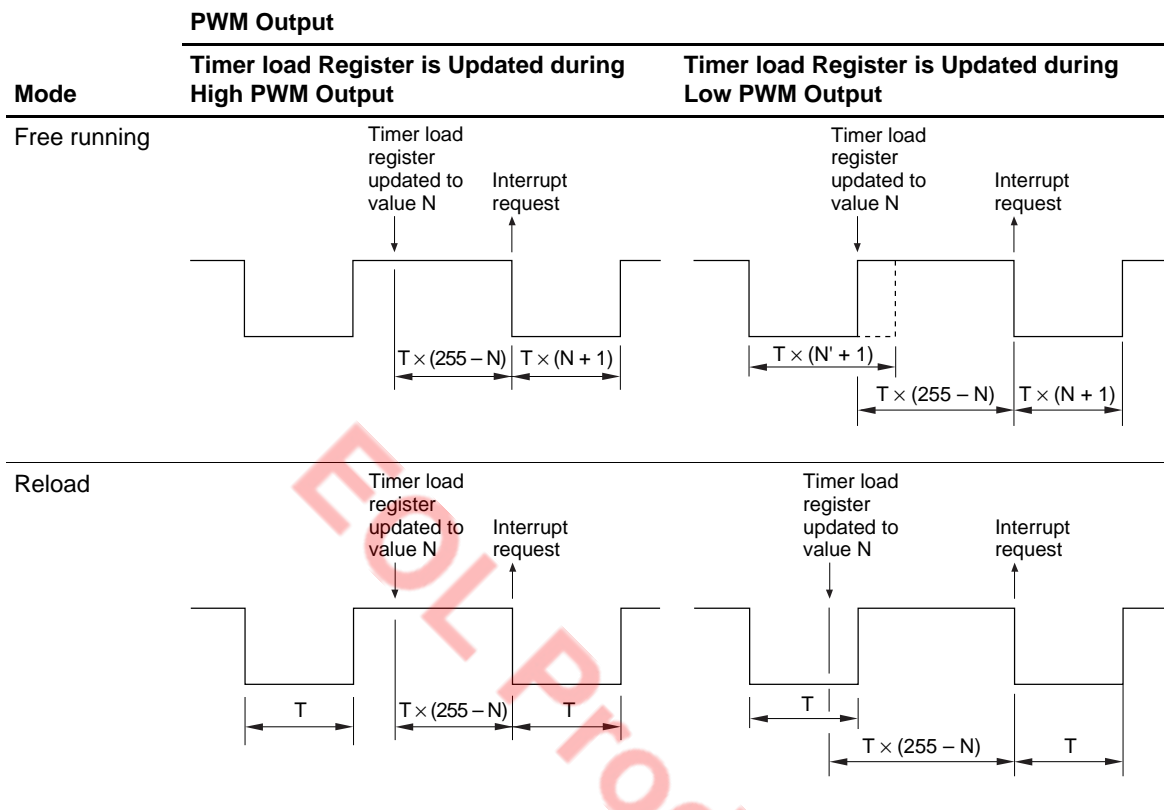

HD404818 Series

Serial Interface

The serial interface transmits/receives 8-bit data serially. It consists of the serial data register, the serial mode register, port mode register A, the octal counter, and the selector (figure 29). Pin $R0_0/\overline{SCK}$ and the transmit clock signal are controlled by the serial mode register. The data of the serial data register can be written and read by software. The data in the serial data register can be shifted synchronously with the transmit clock signal.

The STS instruction starts serial interface operations and resets the octal counter to \$0. The octal counter starts to count at the falling edge of the transmit clock signal (\overline{SCK}) and increments by one at the rising edge of the \overline{SCK} . When the octal counter is reset to \$0 after eight transmit clock signals, or when a transmit/receive operation is discontinued by resetting the octal counter, the serial interrupt request flag will be set.

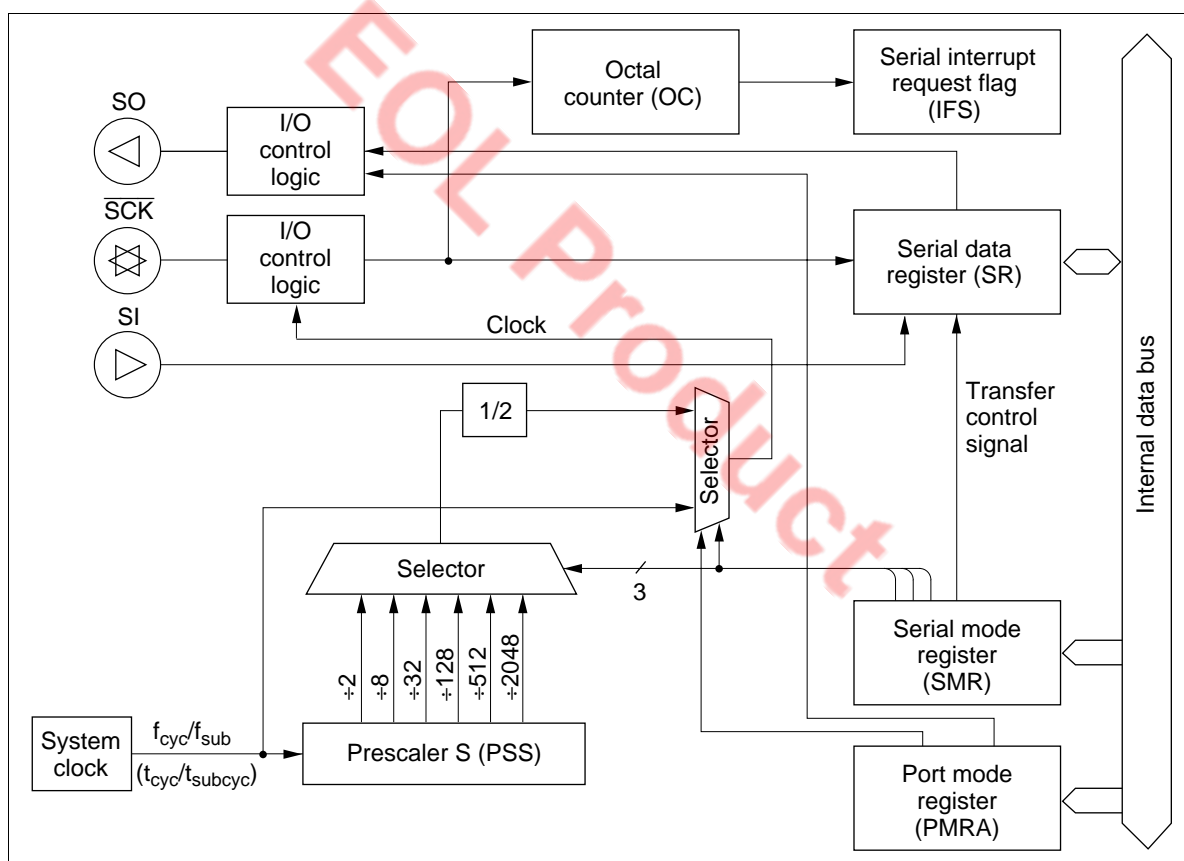

Figure 29 Serial Interface Block Diagram

Selection and Change of the Operation Mode: Table 25 shows the serial interface operation modes which are determined by a combination of the value in the port mode register and in the serial mode register.

Initialize the serial interface by writing to the serial mode register to change the operation mode of the serial interface.

Table 25 Serial Interface Operation Mode

SMR3	PMRA1	PMRA0	Serial Interface Operating Mode
1	0	0	Clock continuous output mode
1	0	1	Transmit mode
1	1	0	Receive mode
1	1	1	Transmit/receive mode

Operating State of Serial Interface: The serial interface has three operating states: the STS waiting state, transmit clock wait state, and transfer state (figure 30).

The STS waiting state is the initialization state of the serial interface internal state. The serial interface enters this state in one of two ways: either by changing the operation mode through a change in the data in the port mode register, or by writing data into the serial mode register. In this state, the serial interface does not operate even if the transmit clock is applied. If the STS instruction is executed then, the serial interface shifts to the transmit clock wait state.

In the transmit clock wait state, the falling edge of the first transmit clock causes the serial interface to shift to the transfer state, while the octal counter counts up and the serial data register shifts simultaneously. As an exception, if the clock continuous output mode is selected, the serial interface stays in transmit clock wait state while the transmit clock outputs continuously. The octal counter becomes 000 again after 8 external transmit clocks or by the execution of the STS instruction, the serial interface then returns to the transmit clock wait state, and the serial interrupt request flag is set simultaneously. In the transfer state the octal counter becomes 000 after 8 internal transmit clocks, the serial interface then enters the STS instruction waiting state, and the serial interrupt request flag is set simultaneously.

When the internal transmit clock is selected, the transmit clock output is triggered by the execution of the STS instruction, and stops after 8 clocks.

Program the SMR again to initialize the internal state of the serial interface when the PMRA is programmed in the transfer state or in the transmit clock wait state. Then the serial interface goes into the STS waiting state.

HD404818 Series

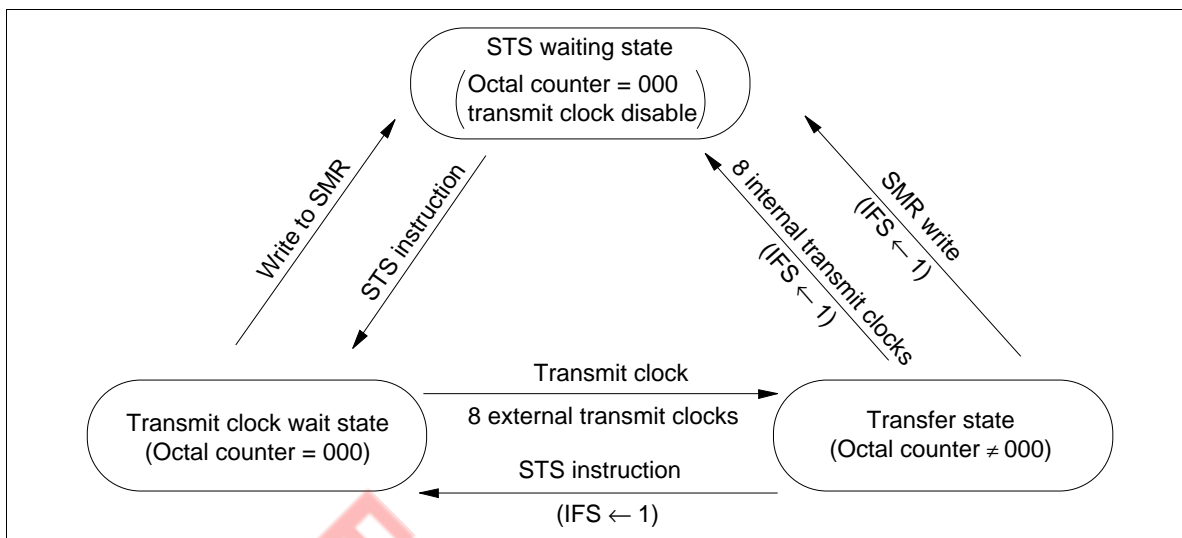

Figure 30 Serial Interface Operation States

Example of Transmit Clock Error Detection: The serial interface malfunctions when the transmit clock is disturbed by external noise. In this case, transmit clock errors can be detected by the procedure shown in figure 31.

If more than 8 transmit clocks are applied in the transmit clock wait state, the state of the serial interface shifts in the following sequence: transfer state, transmit clock wait state, and transfer state again. The serial interrupt request flag should be reset before entering into the STS waiting state by writing data to SMR. This procedure causes the serial interface request flag to be set again.

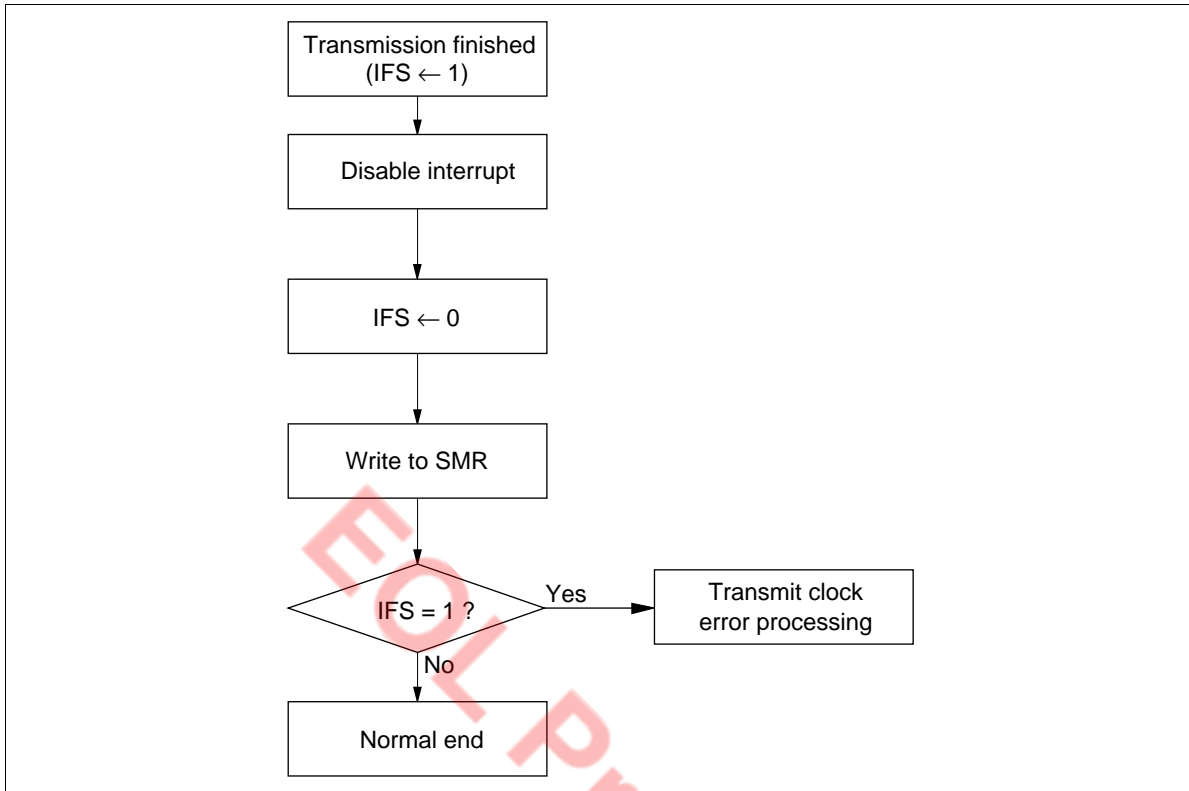

Figure 31 Transmit Clock Error Detection

HD404818 Series

Registers for Serial Interface

Serial Mode Register (SMR: \$005): The 4-bit write-only serial mode register controls the $R0_0/\overline{SCK}$, prescaler divide ratio, and transmit clock source (table 26, figure 32).

A write signal to the serial mode register controls the internal state of the serial interface.

A write signal to the serial mode register stops the serial data register and octal counter from applying the transmit clock, and it also resets the octal counter to \$0 simultaneously. Therefore, when the serial interface is in the transfer state, a write signal causes the serial mode register to cease the data transfer and to set the serial interrupt request flag.

Data in the serial mode register will change in the second instruction cycle after a write instruction to the serial mode register. Therefore, it is required to execute the STS instruction after the data in the serial mode register has been changed completely. The serial mode register will be reset to \$0 by MCU reset.

Serial Data Register (SRL: \$006, SRU: \$007): The 8-bit read/write serial data register consists of low-order digits (SRL: \$006) and high-order digits (SRU: \$007).

The data in the serial data register will be output from the SO pin LSB first synchronously with the falling edge of the transmit clock signal. At the same time, external data will be input from the SI pin to the serial data register synchronously with the rising edge of the transmit clock. Figure 33 shows the I/O timing chart for the transmit clock signal and the data.

The read/write operation of the serial data register should be performed after the completion of data transmit/receive. Otherwise, data accuracy cannot be guaranteed.

Table 26 Serial Mode Register

SMR3	$R0_0/\overline{SCK}$
0	Used as $R0_0$ port input/output pin
1	Used as \overline{SCK} input/output pin

Transmit Clock						
SMR2	SMR1	SMR0	$R0_0/\overline{SCK}$ Port	Clock Source	Prescaler Divide Ratio	System Clock Divide Ratio
0	0	0	\overline{SCK} /output	Prescaler	÷ 2048	÷ 4096
0	0	1	\overline{SCK} /output	Prescaler	÷ 512	÷ 1024
0	1	0	\overline{SCK} /output	Prescaler	÷ 128	÷ 256
0	1	1	\overline{SCK} /output	Prescaler	÷ 32	÷ 64
1	0	0	\overline{SCK} /output	Prescaler	÷ 8	÷ 16
1	0	1	\overline{SCK} /output	Prescaler	÷ 2	÷ 4
1	1	0	\overline{SCK} /output	System clock	—	÷ 1
1	1	1	\overline{SCK} /input	External clock	—	—

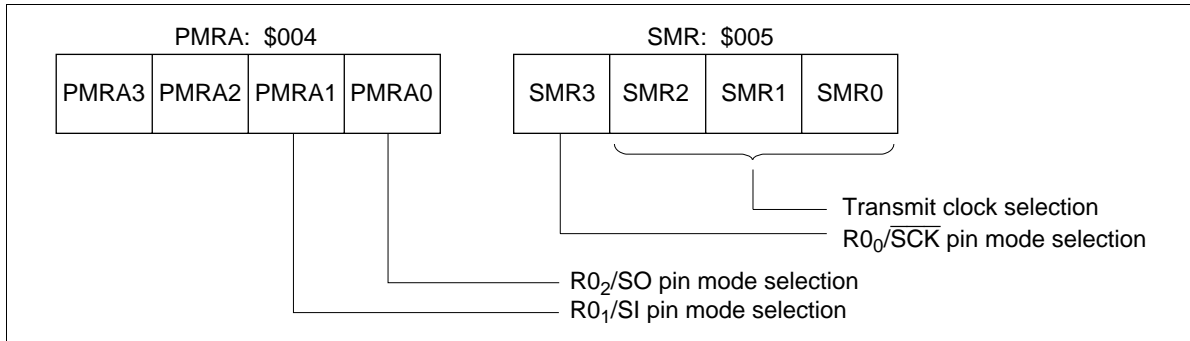

Figure 32 Configurations and Functions of the Mode Registers

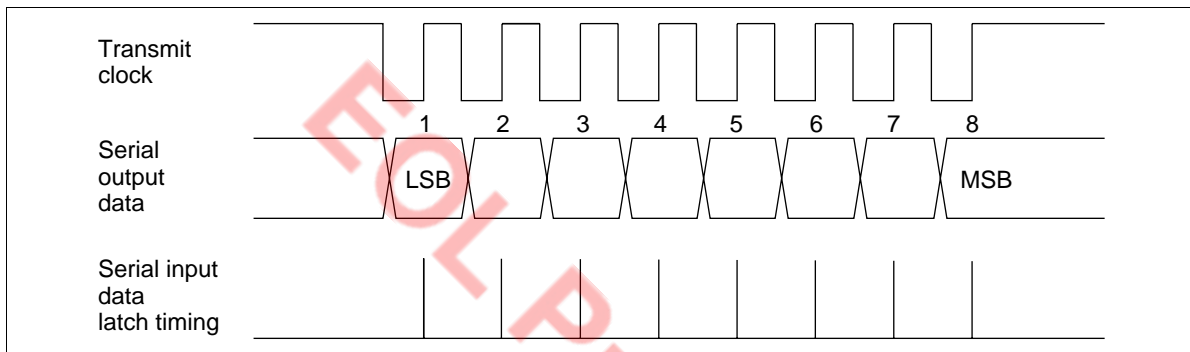

Figure 33 Serial Interface I/O Timing

HD404818 Series

LCD Controller/Driver

The MCU contains four common signal pins, the controller, and the driver. The controller and the driver drive 32 segment signal pins. The controller consists of display data RAM, the LCD control register (LCR), and the LCD duty-cycle/clock control register (LMR) (figure 34). Four programmable duty cycles and LCD clocks are available. Since the MCU contains a dual port RAM, display data can be transferred to segment signal pins automatically without program control. When selecting the 32-kHz oscillation clock as the LCD clock source, the system allows the LCD to display even in watch mode, in which the system clock halts.

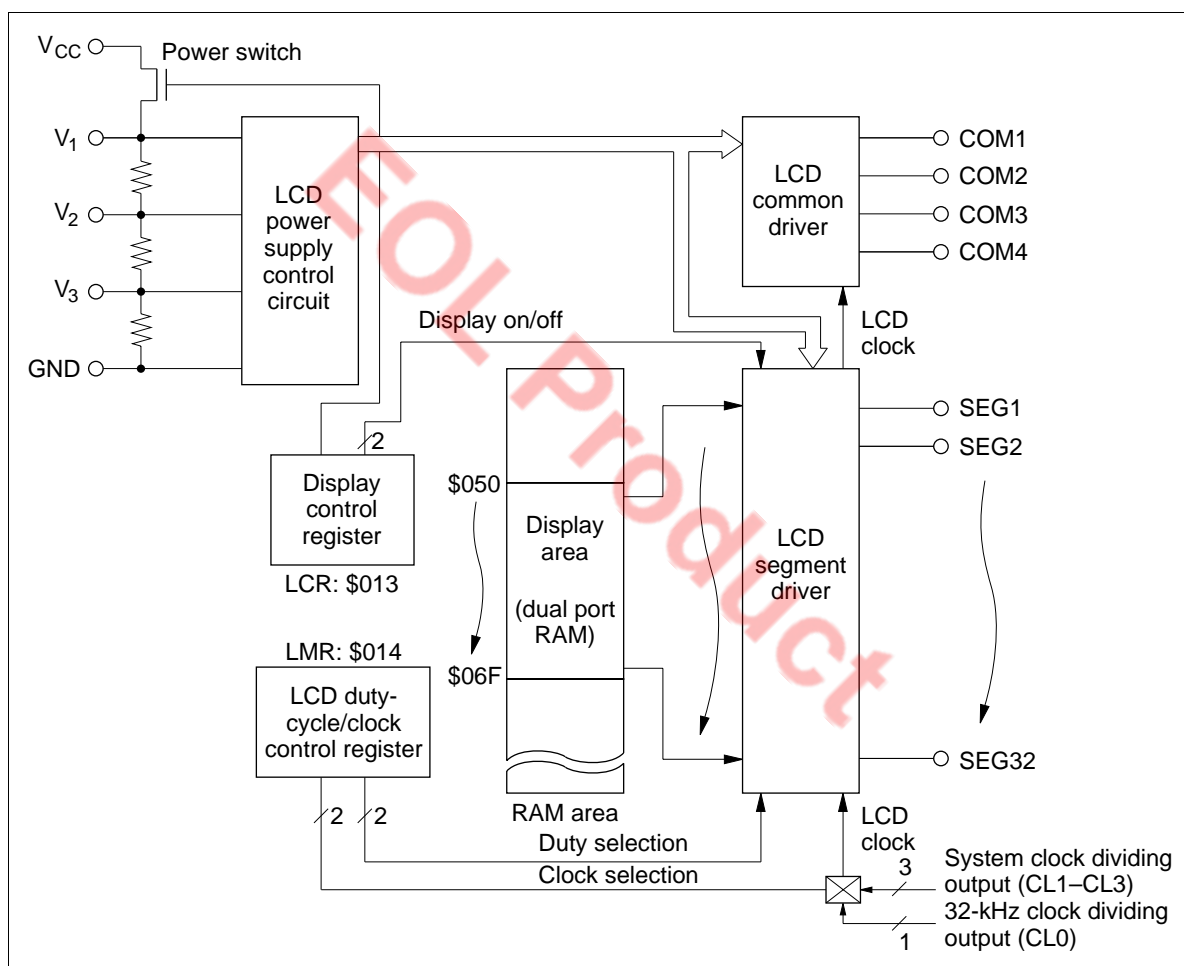

Figure 34 LCD Controller/Driver Configuration

LCD Data Area and Segment Data (\$050 to \$06F): Figure 35 shows the configuration of the LCD RAM area. Each bit of this area, corresponding to four types of duty cycles, can be transmitted to the segment driver as display data by programming the area corresponding to the duty cycle.

	Bit 3	Bit 2	Bit 1	Bit 0		Bit 3	Bit 2	Bit 1	Bit 0		
80	SEG1	SEG1	SEG1	SEG1	\$050	96	SEG17	SEG17	SEG17	SEG17	\$060
81	SEG2	SEG2	SEG2	SEG2	\$051	97	SEG18	SEG18	SEG18	SEG18	\$061
82	SEG3	SEG3	SEG3	SEG3	\$052	98	SEG19	SEG19	SEG19	SEG19	\$062
83	SEG4	SEG4	SEG4	SEG4	\$053	99	SEG20	SEG20	SEG20	SEG20	\$063
84	SEG5	SEG5	SEG5	SEG5	\$054	100	SEG21	SEG21	SEG21	SEG21	\$064
85	SEG6	SEG6	SEG6	SEG6	\$055	101	SEG22	SEG22	SEG22	SEG22	\$065
86	SEG7	SEG7	SEG7	SEG7	\$056	102	SEG23	SEG23	SEG23	SEG23	\$066
87	SEG8	SEG8	SEG8	SEG8	\$057	103	SEG24	SEG24	SEG24	SEG24	\$067
88	SEG9	SEG9	SEG9	SEG9	\$058	104	SEG25	SEG25	SEG25	SEG25	\$068
89	SEG10	SEG10	SEG10	SEG10	\$059	105	SEG26	SEG26	SEG26	SEG26	\$069
90	SEG11	SEG11	SEG11	SEG11	\$05A	106	SEG27	SEG27	SEG27	SEG27	\$06A
91	SEG12	SEG12	SEG12	SEG12	\$05B	107	SEG28	SEG28	SEG28	SEG28	\$06B
92	SEG13	SEG13	SEG13	SEG13	\$05C	108	SEG29	SEG29	SEG29	SEG29	\$06C
93	SEG14	SEG14	SEG14	SEG14	\$05D	109	SEG30	SEG30	SEG30	SEG30	\$06D
94	SEG15	SEG15	SEG15	SEG15	\$05E	110	SEG31	SEG31	SEG31	SEG31	\$06E
95	SEG16	SEG16	SEG16	SEG16	\$05F	111	SEG32	SEG32	SEG32	SEG32	\$06F
	COM4	COM3	COM2	COM1			COM4	COM3	COM2	COM1	

Figure 35 Configuration of LCD RAM Area (dual port RAM)

LCD Control Register (LCR: \$013): The LCD control register is a 3-bit write-only register which controls the blanking of the LCD, activation of the power switch, and display in watch mode/subactive mode (table 27, figure 36).

- Blank/display
Blank: Segment signal is faded regardless of the LCD RAM data.
Display: LCD RAM data is transmitted as a segment signal.
- Power switch on/off
Off: Power switch is off.
On: Power switch is on and V_1 is V_{CC} .
- Watch mode/subactive mode display
Off: In the watch mode/subactive mode, all common/segment pins are fixed to GND, and the power switch is off.
On: In the watch mode/subactive mode, LCD RAM data is transmitted as a segment signal.

LCD Duty-Cycle/Clock Control Register (LMR: \$014): The LCD duty-cycle/clock control register is a write-only register which specifies four display duty cycles and the reference clock for the LCD (table 28, figure 36).

HD404818 Series

Table 27 LCD Control Register

LCR BIT 2	Watch Mode/ Display	Subactive Mode	LCR BIT 1	Power Switch On/Off	LCR BIT 0	Blank/ Display
0	Off		0	Off	0	Blank
1	On		1	On	1	Display

Note: With the LCD in watch mode, use the divider output of the 32-kHz oscillator as an LCD clock and set LCR bit 2 to 1. When the system oscillator divider output is used as an LCD clock, set LCR bit 2 to 0.

Table 28 LCD Duty-Cycle/Clock Control Register

LMR

Bit 3	Bit 2	Bit 1	Bit 0	Duty Cycle Select/Input Clock Select
—	—	0	0	1/4 duty cycle
—	—	0	1	1/3 duty cycle
—	—	1	0	1/2 duty cycle
—	—	1	1	Static
0	0	—	—	CL0 (32.768 kHz/64; when 32.768-kHz oscillator is used)
0	1	—	—	CL1 ($f_{\text{cyc}}/256$)
1	0	—	—	CL2 ($f_{\text{cyc}}/2048$)
1	1	—	—	CL3 (Refer to table 29)

Note: f_{cyc} is the system oscillator divider output.

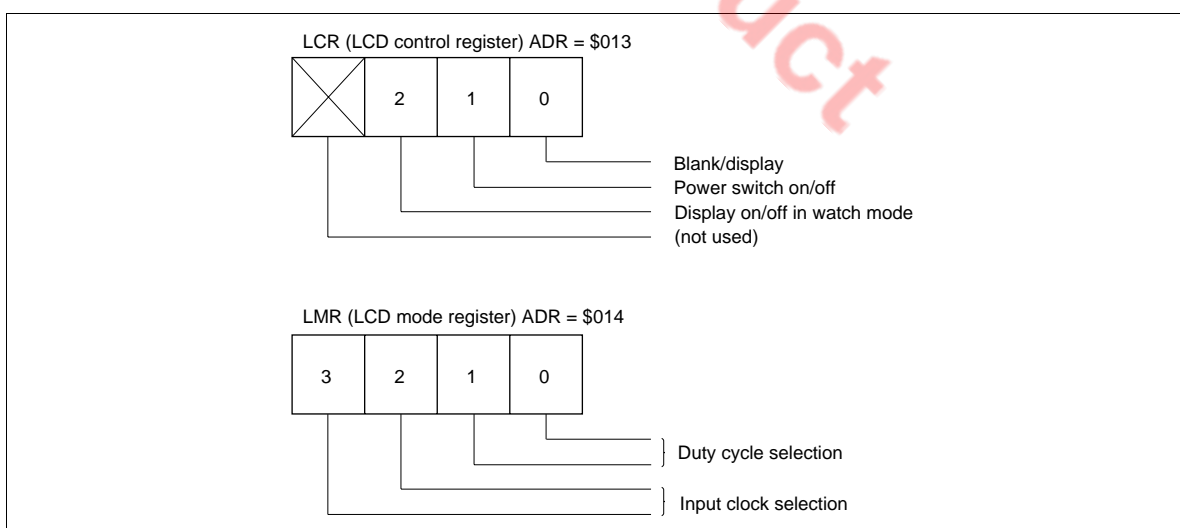

Figure 36 LCD Control Register

Table 29 LCD Frame Frequency

Static	LMR							
	Bit 3	Bit 2	Bit 3	Bit 2	Bit 3	Bit 2	Bit 3	Bit 2
Instruction cycle time	0	0	0	1	1	0	1	1
	CL0		CL1		CL2		CL3*	
10 μ s	512 Hz		390.6 Hz		48.8 Hz		24.4 Hz/64 Hz	
1 μ s	512 Hz		3906 Hz		488Hz		244 Hz/64 Hz	

1/2 Duty Cycle	LMR							
	Bit 3	Bit 2	Bit 3	Bit 2	Bit 3	Bit 2	Bit 3	Bit 2
Instruction cycle time	0	0	0	1	1	0	1	1
	CL0		CL1		CL2		CL3*	
10 μ s	256 Hz		195.3 Hz		24.4 Hz		12.2 Hz/32 Hz	
1 μ s	256 Hz		1953 Hz		244 Hz		122 Hz/32 Hz	

1/3 Duty Cycle	LMR							
	Bit 3	Bit 2	Bit 3	Bit 2	Bit 3	Bit 2	Bit 3	Bit 2
Instruction cycle time	0	0	0	1	1	0	1	1
	CL0		CL1		CL2		CL3*	
10 μ s	170.6 Hz		130.2 Hz		16.3 Hz		8.1 Hz/21.3 Hz	
1 μ s	170.6 Hz		1302 Hz		162.6 Hz		81.3 Hz/21.3 Hz	

1/4 Duty Cycle	LMR							
	Bit 3	Bit 2	Bit 3	Bit 2	Bit 3	Bit 2	Bit 3	Bit 2
Instruction cycle time	0	0	0	1	1	0	1	1
	CL0		CL1		CL2		CL3*	
10 μ s	128 Hz		97.7 Hz		12.2 Hz		6.1 Hz/16 Hz	
1 μ s	128 Hz		977 Hz		122 Hz		61 Hz/16 Hz	

Note: * Division ratio differs depending on the value of bit 3 of timer mode register A (TMA3 = 0/TMA3 = 1).
 If TMA3 = 0, CL3 = fcyc x duty cycle/4096; if TMA3 = 1, CL3 = 32.768 kHz x duty cycle/512.

HD404818 Series

Large LCD Panel Driving and Driving Voltage (V_{LCD}): When using a large LCD panel, lower the dividing resistance by attaching external resistors in parallel with the internal dividing resistors (figure 37).

Since the liquid crystal display board is of a matrix configuration, the path of the charge/discharge current through the load capacitors is very complicated. Moreover, since it varies depending on display conditions, the value of resistance cannot be determined by simply referring to the load capacitance of the liquid crystal display. The value of resistance must be experimentally determined according to the demand for power consumption of the equipment in which the liquid crystal display is implemented. Capacitor C (0.1 to 0.3 μ F) is recommended to be attached. In general, R is 1 k Ω to 10 k Ω .

Figure 37 shows a connection when changing the liquid crystal driving voltage (V_{LCD}). In this case, the power supply switch for the dividing resistors (power switch) must be turned off. (Bit 1 of the LCR register is 0.)

EOL Product

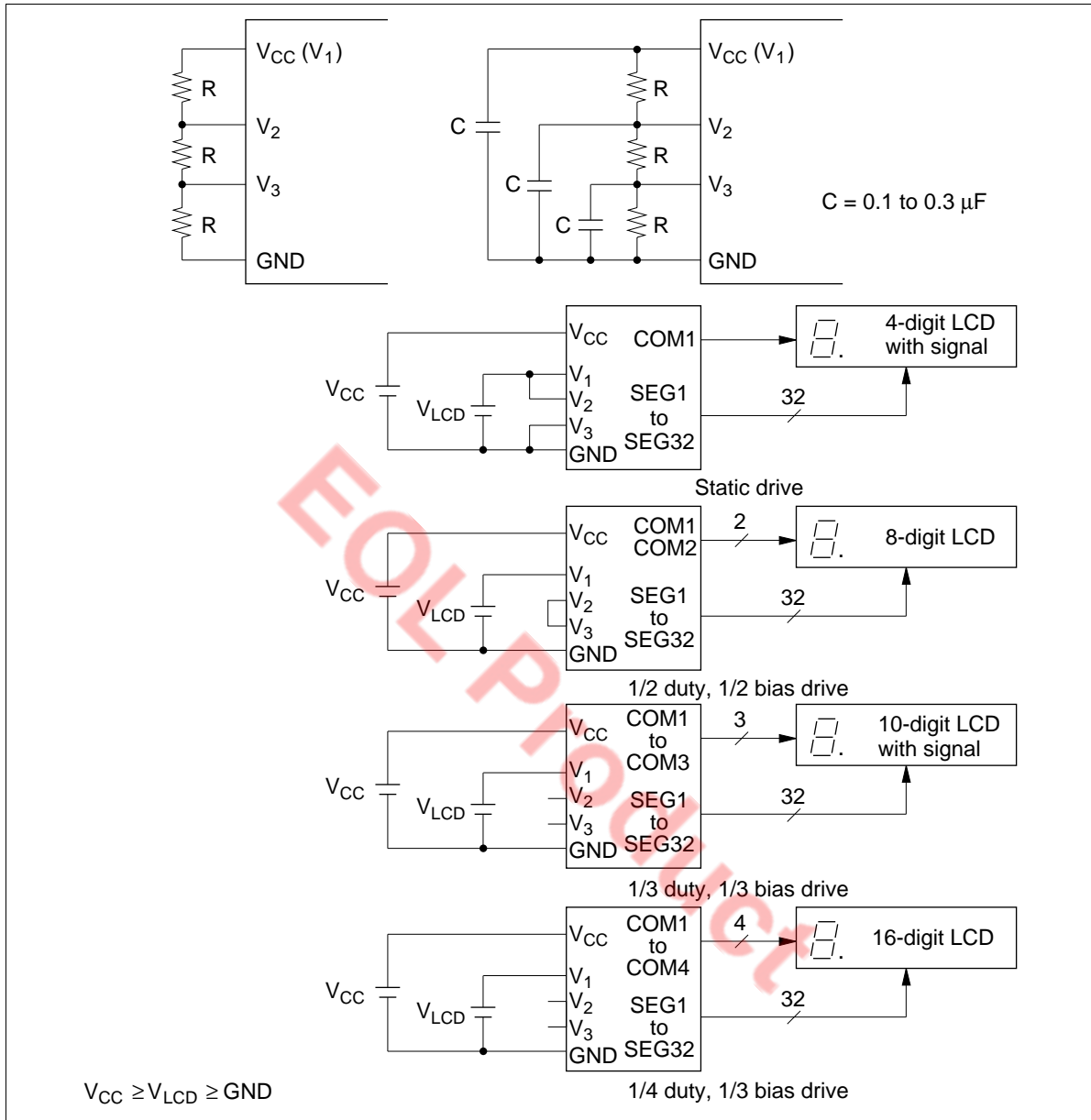

Figure 37 Examples of LCD Connections

HD404818 Series

Pin Description in PROM Mode

The HD4074818 and HD407L4818 are ZTAT™ microcomputers incorporating a PROM. In the PROM mode, the MCU does not operate and the HD4074818 and HD407L4818 can program the on-chip PROM.

Pin Number		MCU Mode		PROM Mode		Pin Number		MCU Mode		PROM Mode	
FP-80B	FP-80A TFP-80	Pin Name	I/O	Pin Name	I/O	FP-80B	FP-80A TFP-80	Pin Name	I/O	Pin Name	I/O
1	79	D ₂	I/O	O ₂	I/O	28	26	R2 ₃	I/O	A ₁₂	I
2	80	D ₃	I/O	O ₃	I/O	29	27	R3 ₀	I/O	A ₁₃	I
3	1	D ₄	I/O	O ₄	I/O	30	28	R3 ₁ /TIMO	I/O	A ₁₄	I
4	2	D ₅	I/O	O ₅	I/O	31	29	R3 ₂ /INT ₀	I/O	CE	I
5	3	D ₆	I/O	O ₆	I/O	32	30	R3 ₃ /INT ₁	I/O	OE	I
6	4	D ₇	I/O	O ₇	I/O	33	31	SEG1	O		
7	5	D ₈	I/O			34	32	SEG2	O		
8	6	D ₉	I/O			35	33	SEG3	O		
9	7	D ₁₀	I	V _{PP}		36	34	SEG4	O		
10	8	D ₁₁ /V _{Cref}	I	A ₉	I	37	35	SEG5	O		
11	9	D ₁₂ /COMP ₀	I	M ₀	I	38	36	SEG6	O		
12	10	D ₁₃ /COMP ₁	I	M ₁	I	39	37	SEG7	O		
13	11	TEST	I	TEST	I	40	38	SEG8	O		
14	12	X1	I	GND		41	39	SEG9	O		
15	13	X2	O			42	40	SEG10	O		
16	14	GND		GND		43	41	SEG11	O		
17	15	R0 ₀ /SCK	I/O	A ₁	I	44	42	SEG12	O		
18	16	R0 ₁ /SI	I/O	A ₂	I	45	43	SEG13	O		
19	17	R0 ₂ /SO	I/O	A ₃	I	46	44	SEG14	O		
20	18	R0 ₃	I/O	A ₄	I	47	45	SEG15	O		
21	19	R1 ₀	I/O	A ₅	I	48	46	SEG16	O		
22	20	R1 ₁	I/O	A ₆	I	49	47	SEG17	O		
23	21	R1 ₂	I/O	A ₇	I	50	48	SEG18	O		
24	22	R1 ₃	I/O	A ₈	I	51	49	SEG19	O		
25	23	R2 ₀	I/O	A ₉	I	52	50	SEG20	O		
26	24	R2 ₁	I/O	A ₁₀	I	53	51	SEG21	O		
27	25	R2 ₂	I/O	A ₁₁	I	54	52	SEG22	O		

HD404818 Series

Pin Number		MCU Mode		PROM Mode		Pin Number		MCU Mode		PROM Mode	
FP-80B	FP-80A TFP-80	Pin Name	I/O	Pin Name	I/O	FP-80B	FP-80A TFP-80	Pin Name	I/O	Pin Name	I/O
55	53	SEG23	O			68	66	COM4	O		
56	54	SEG24	O			69	67	V ₁			
57	55	SEG25	O			70	68	V ₂			
58	56	SEG26	O			71	69	V ₃		V _{CC}	
59	57	SEG27	O			72	70	NUMO			
60	58	SEG28	O			73	71	NUMO			
61	59	SEG29	O			74	72	NUMG		V _{CC}	
62	60	SEG30	O			75	73	V _{CC}		V _{CC}	
63	61	SEG31	O			76	74	OSC ₁	I	V _{CC}	
64	62	SEG32	O			77	75	OSC ₂	O		
65	63	COM1	O			78	76	RESET	I	RESET	I
66	64	COM2	O			79	77	D ₀	I/O	O ₀	I/O
67	65	COM3	O			80	78	D ₁	I/O	O ₁	I/O

Note: I/O: Input/output pin, I: Input pin, O: Output pin

HD404818 Series

Programmable ROM Operation

The MCU on-chip PROM is programmed in PROM mode. PROM mode is set by pulling $\overline{\text{TEST}}$, $\overline{\text{M}}_0$, and $\overline{\text{M}}_1$ low, and RESET high, as shown in figure 38. In PROM mode, the MCU does not operate. It can be programmed like a standard 27256 EPROM using a standard PROM programmer and an 80-to-28-pin socket adapter. Table 31 lists the recommended PROM programmers and socket adapters.

Since an instruction of the HMCS400 series consists of 10 bits, the HMCS400 series microcomputer incorporates a conversion circuit to enable the use of a general-purpose PROM programmer. By this circuit, an instruction is read or programmed using two addresses, a lower 5 bits and upper 5 bits. For example, if 8 kwords of on-chip PROM are programmed by a general-purpose PROM programmer, 16 kbytes of addresses (\$0000–\$3FFF) should be specified.

Programming and Verification

The MCU can be programmed at high speed without causing voltage stress or affecting data reliability.

Table 30 shows how programming and verification modes are selected.

Precautions

1. Addresses \$0000 to \$3FFF must be specified if the PROM is programmed by a PROM programmer. If addresses of \$4000 or higher are accessed, the PROM may not be programmed or verified. Note that plastic package types cannot be erased and reprogrammed. Data in unused addresses must be set to \$FF.
2. Ensure that the PROM programmer, socket adapter, and LSI match. Using the wrong programmer for the socket adapter may cause an overvoltage and damage the LSI. Make sure that the LSI is firmly fixed in the socket adapter, and that the socket adapter is firmly fixed onto the programmer.
3. The PROM should be programmed with $V_{pp} = 12.5$ V. Other PROMs use 21 V. If 21 V is applied to the MCU, the LSI may be permanently damaged. 12.5 V is the Intel 27256 setting.

Table 30 PROM Mode Selection

Mode	Pin			
	$\overline{\text{CE}}$	$\overline{\text{OE}}$	V_{pp}	$\text{O}_0\text{--O}_7$
Programming	Low	High	V_{pp}	Data input
Verify	High	Low	V_{pp}	Data output
Programming inhibited	High	High	V_{pp}	High impedance

Table 31 PROM Programmiers and Socket Adapters

PROM Programmer		Socket Adapter		
Manufacturer	Type Name	Manufacturer	Type Name	Package Type
DATA I/O	121B 29B	Hitachi	HS460ESF01H	FP-80B
			HS460ESH01H	FP-80A
			HS461EST01H	TFP-80
AVAL Corp.	PKW-1000	Hitachi	HS460ESF01H	FP-80B
			HS460ESH01H	FP-80A
			HS461EST01H	TFP-80

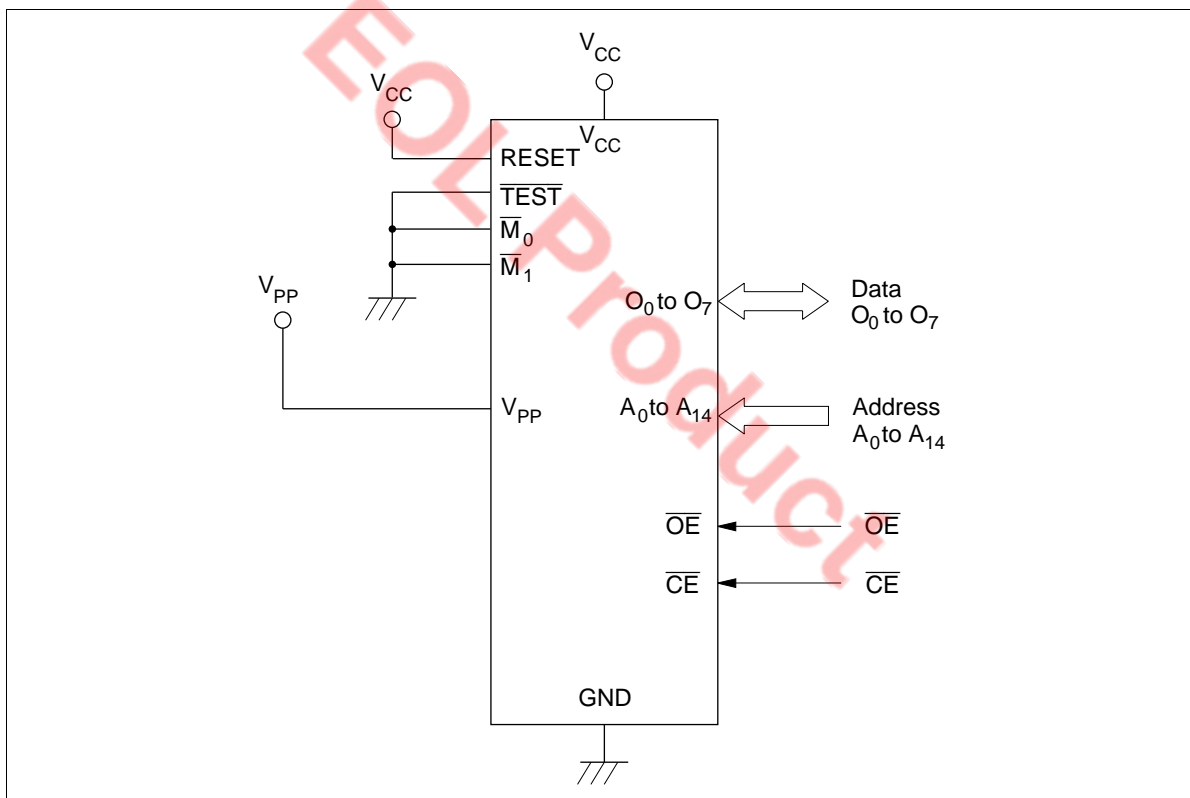

Figure 38 PROM Mode Function Diagram

HD404818 Series

Addressing Modes

RAM Addressing Modes

As shown in figure 39, the MCU has three RAM addressing modes: register indirect addressing, direct addressing, and memory register addressing.

Register Indirect Addressing Mode: The W register, X register, and Y register contents (10 bits total) are used as the RAM address.

Direct Addressing Mode: A direct addressing instruction consists of two words, with the word (10 bits) following the opcode used as the RAM address.

Memory Register Addressing Mode: The memory registers (16 digits from \$040 to \$04F) are accessed by executing the LAMR and XMRA instructions.

ROM Addressing Modes and the P Instruction

The MCU has four kinds of ROM addressing modes as shown in figure 40.

Direct Addressing Mode: The program can branch to any address in ROM memory space by executing the JMPL, BRL, or CALL instruction. These instructions replace the 14 program counter bits (PC_{13} to PC_0) with 14-bit immediate data.

Current Page Addressing Mode: The MCU has 32 pages of ROM with 256 words per page. By executing the BR instruction, the program can branch to an address in the current page. This instruction replaces the lower eight bits of the program counter (PC_7 to PC_0) with 8-bit immediate data.

When the BR instruction is on a page boundary ($256n + 255$) (figure 41), executing it transfers the PC contents to the next page according to the hardware architecture. Consequently, the program branches to the next page when the BR instruction is used on a page boundary. The HMCS400 series cross macroassembler has an automatic paging facility for ROM pages.

Zero-Page Addressing Mode: By executing the CAL instruction, the program can branch to the zero-page subroutine area, which is located at \$0000–\$003F. When the CAL instruction is executed, 6-bit immediate data is placed in the lower six bits of the program counter (PC_5 to PC_0) and 0s are placed in the higher eight bits (PC_{13} to PC_6).

Table Data Addressing Mode: By executing the TBR instruction, the program can branch to the address determined by the contents of the 4-bit immediate data, accumulator, and B register.

P Instruction: ROM data addressed by table data addressing can be referenced by the P instruction (figure 42). When bit 8 in the referred ROM data is 1, eight bits of ROM data are written into the accumulator and B register. When bit 9 is 1, eight bits of ROM data is written into the R1 and R2 port output registers. When both bits 8 and 9 are 1, ROM data is written into the accumulator and B register, and also to the R1 and R2 port output registers at the same time.

The P instruction has no effect on the program counter.

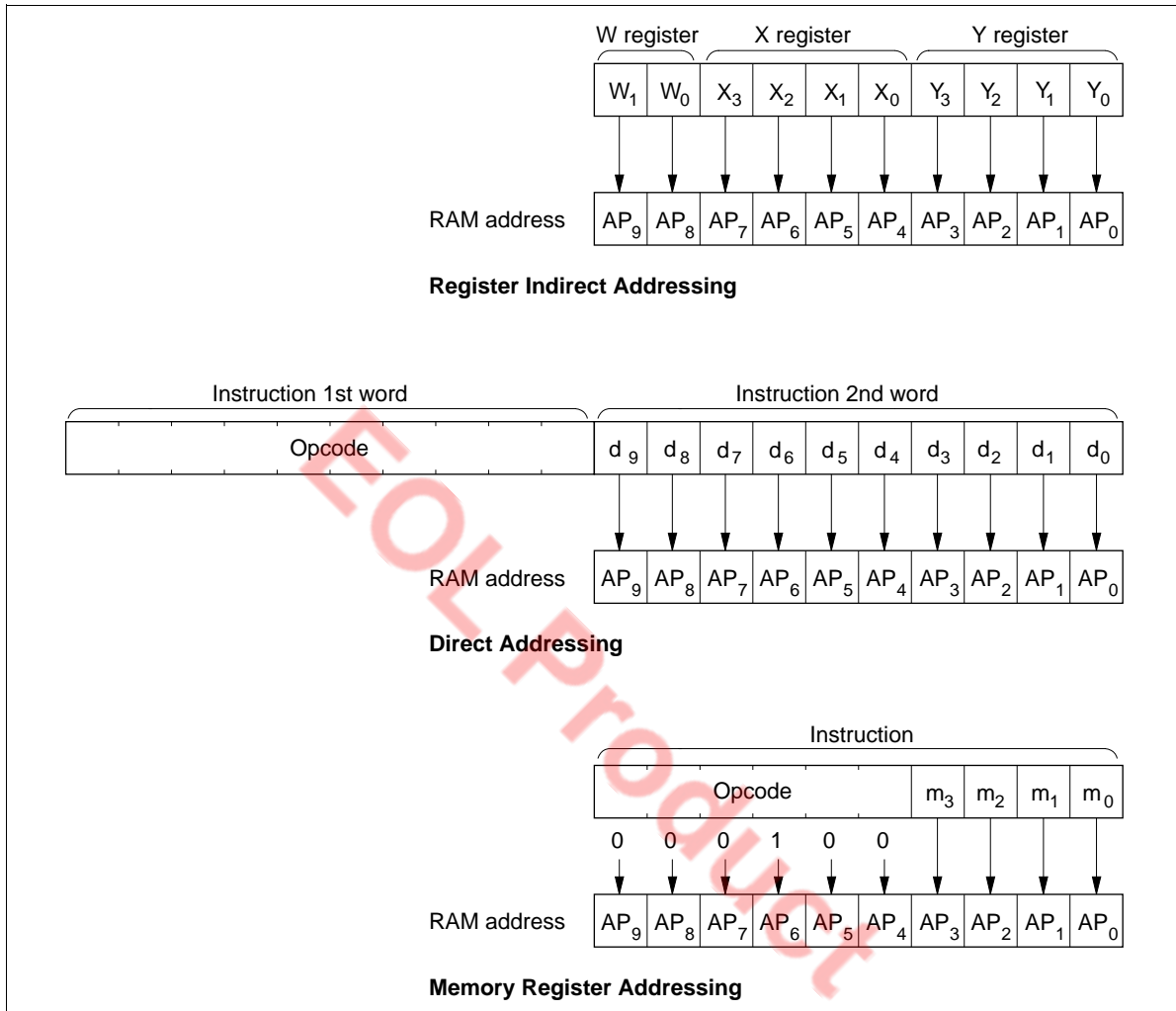

Figure 39 RAM Addressing Modes

HD404818 Series

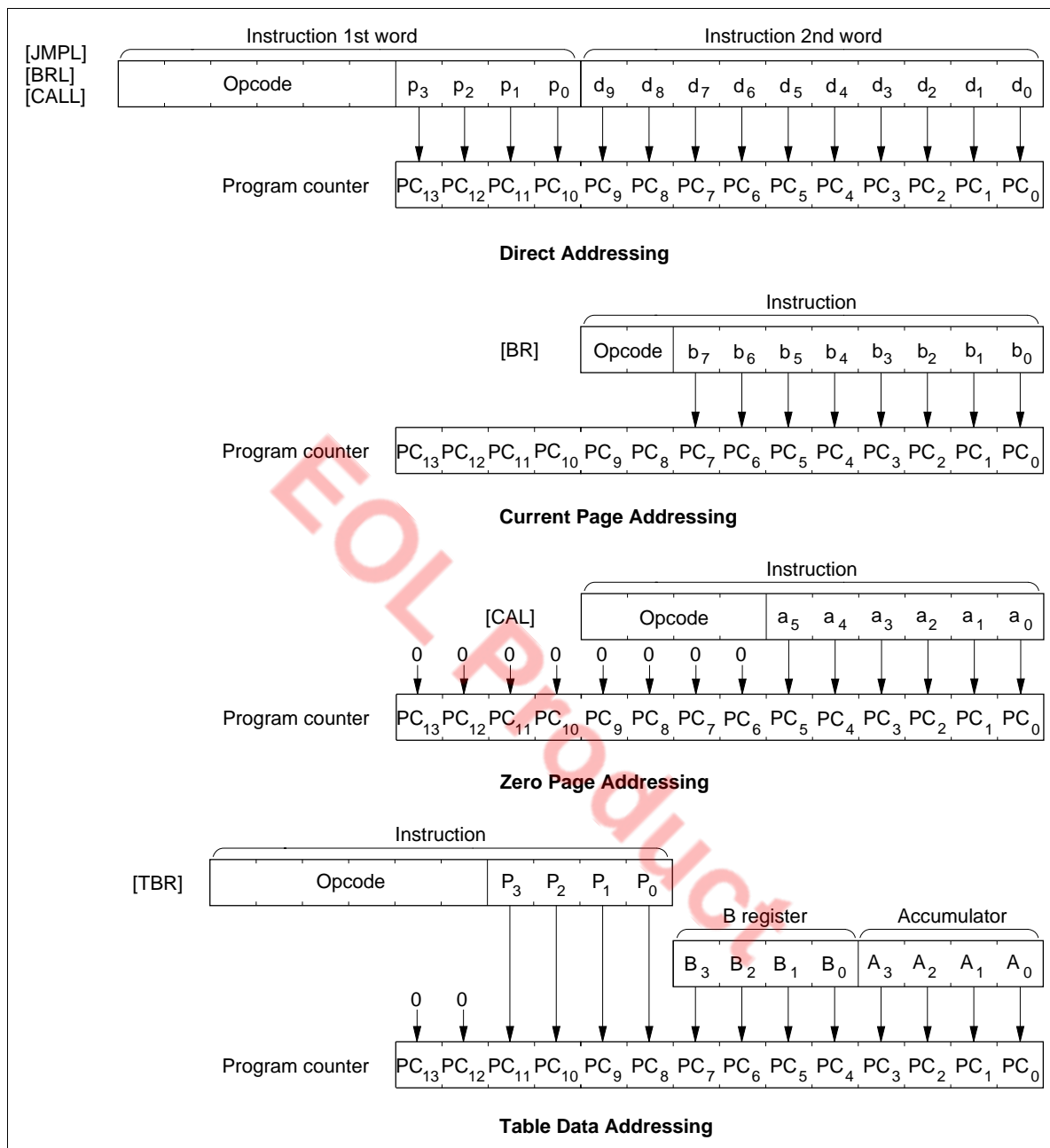

Figure 40 ROM Addressing Modes

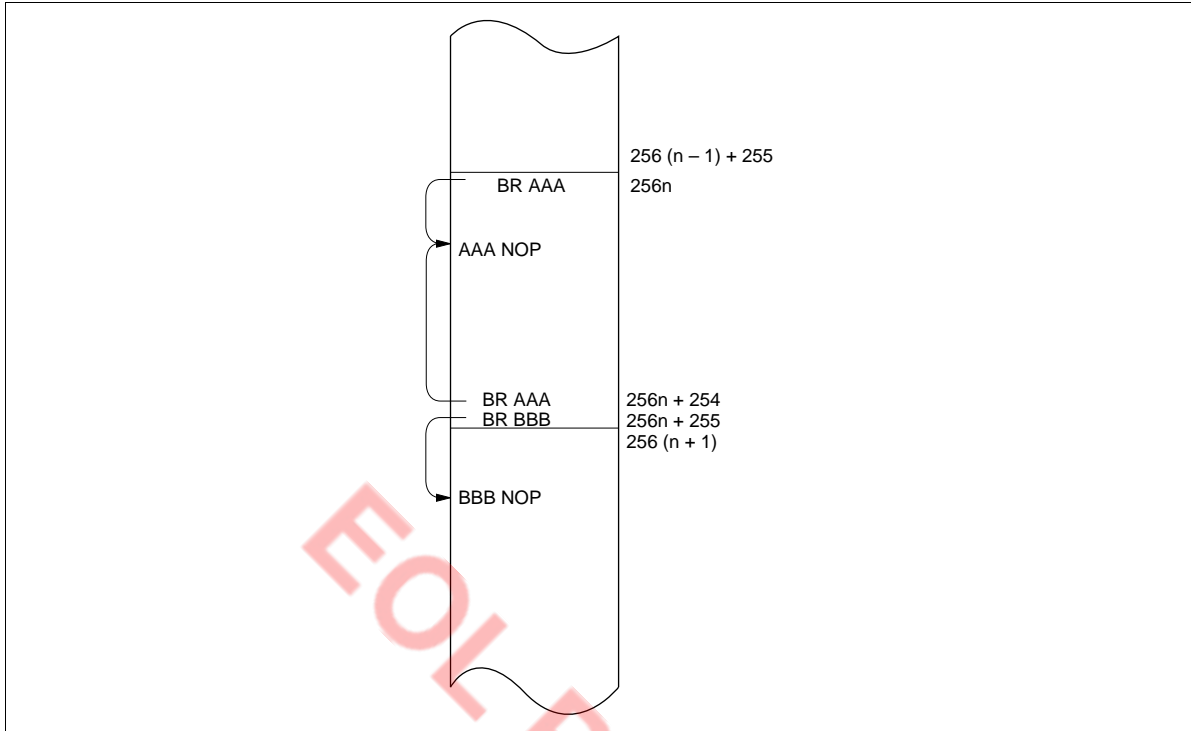

Figure 41 Page Boundary between BR Instruction and Branch Destination

HD404818 Series

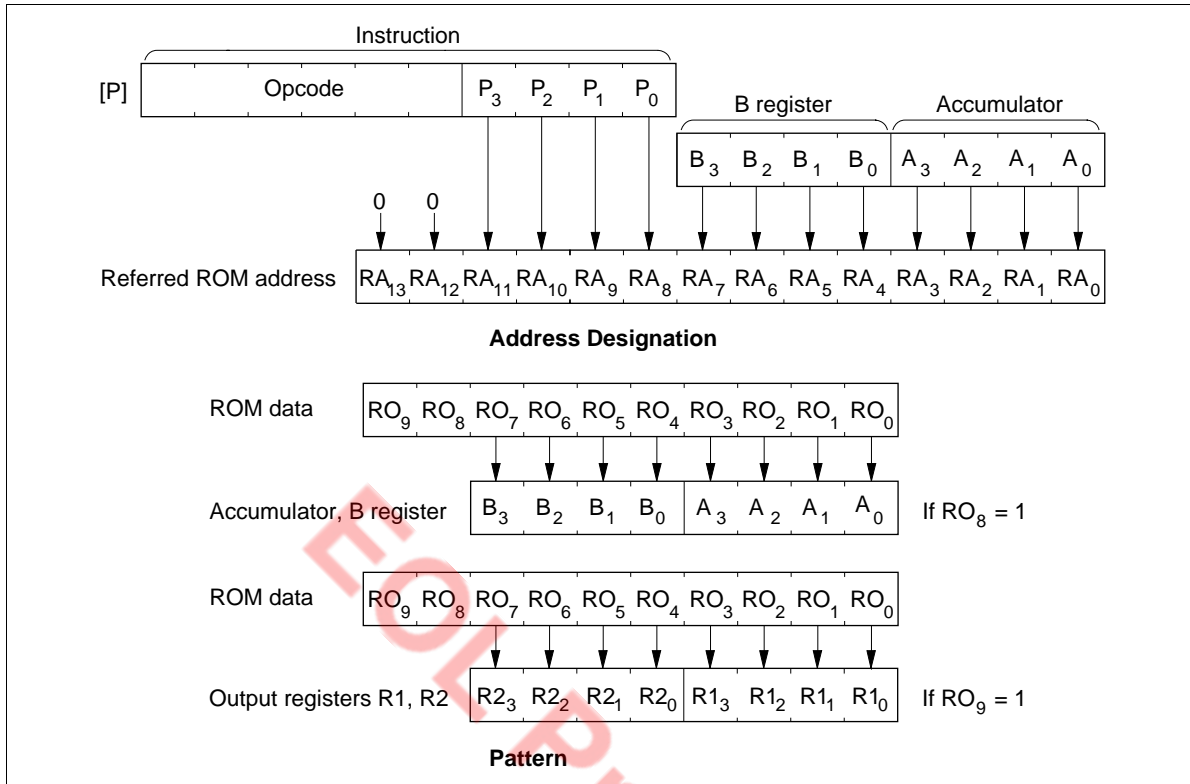

Figure 42 P Instruction

Absolute Maximum Ratings

HD404812, HD404814, HD404816, HD404818, and HD4074818 Absolute Maximum Ratings

Item	Symbol	Value	Unit	Notes
Supply voltage	V_{CC}	-0.3 to +7.0	V	
Programming voltage	V_{PP}	-0.3 to +14.0	V	1
Pin voltage	V_T	-0.3 to $V_{CC} + 0.3$	V	
Total permissible input current	$\sum I_o$	100	mA	2
Total permissible output current	$-\sum I_o$	50	mA	3
Maximum input current	I_o	4	mA	4, 5
		30	mA	4, 6
Maximum output current	$-I_o$	4	mA	7, 8
Operating temperature	T_{opr}	-20 to +75	°C	
Storage temperature	T_{stg}	-55 to +125	°C	

Notes: Permanent damage may occur if these absolute maximum ratings are exceeded. Normal operation should be under the conditions of the electrical characteristics. If these conditions are exceeded, it may cause a malfunction or affect the reliability of the LSI.

1. D_{10} (V_{PP}) of the HD4074818.
2. Total permissible input current is the sum of the input currents which flow in from all I/O pins to GND simultaneously.
3. Total permissible output current is the sum of the output currents which flow out from V_{CC} to all I/O pins simultaneously.
4. Maximum input current is the maximum amount of input current from each I/O pin to GND.
5. R0–R3.
6. D_0 – D_9 .
7. Maximum output current is the maximum amount of output current from V_{CC} to each I/O pin.
8. D_0 – D_9 and R0–R3.

HD404818 Series

HD40L4812, HD40L4814, HD40L4816, HD40L4818, and HD407L4818 Absolute Maximum Ratings

Item	Symbol	Value	Unit	Notes
Supply voltage	V_{CC}	-0.3 to +7.0	V	
Programming voltage	V_{PP}	-0.3 to +14.0	V	1
Pin voltage	V_T	-0.3 to $V_{CC} + 0.3$	V	
Total permissible input current	$\sum I_o$	100	mA	2
Total permissible output current	$-\sum I_o$	50	mA	3
Maximum input current	I_o	4	mA	4, 5
		30	mA	4, 6
Maximum output current	$-I_o$	4	mA	7, 8
Operating temperature	T_{opr}	-20 to +75	°C	
Storage temperature	T_{stg}	-55 to +125	°C	

Notes: Permanent damage may occur if these absolute maximum ratings are exceeded. Normal operation should be under the conditions of the electrical characteristics. If these conditions are exceeded, it may cause a malfunction or affect the reliability of the LSI.

1. D_{10} (V_{PP}) of the HD407L4818.
2. Total permissible input current is the sum of the input currents which flow in from all I/O pins to GND simultaneously.
3. Total permissible output current is the sum of the output currents which flow out from V_{CC} to all I/O pins simultaneously.
4. Maximum input current is the maximum amount of input current from each I/O pin to GND.
5. R0-R3.
6. D_0 - D_9 .
7. Maximum output current is the maximum amount of output current from V_{CC} to each I/O pin.
8. D_0 - D_9 and R0-R3.

Electrical Characteristics for Standard-Voltage

HD404812, HD404814, HD404816, HD404818, and HD4074818 Electrical Characteristics

DC Characteristics (HD404812, HD404814, HD404816, HD404818: $V_{CC} = 4$ to 6 V; HD4074818: $V_{CC} = 4$ to 5.5 V; $GND = 0$ V, $T_a = -20^\circ\text{C}$ to $+75^\circ\text{C}$, unless otherwise specified)

Item	Symbol	Pin	Min	Typ	Max	Unit	Test Condition	Notes
Input high voltage	V_{IH}	RESET, \overline{SCK} , \overline{INT}_0 , SI, \overline{INT}_1	$0.8V_{CC}$		$V_{CC} + 0.3$	V		
		OSC ₁	$V_{CC} - 0.5$		$V_{CC} + 0.3$	V		
Input low voltage	V_{IL}	RESET, \overline{SCK} , \overline{INT}_0 , SI, \overline{INT}_1	-0.3		$0.2V_{CC}$	V		
		OSC ₁	-0.3		0.5	V		
Output high voltage	V_{OH}	\overline{SCK} , TIMO, SO	$V_{CC} - 1.0$			V	$-I_{OH} = 1.0$ mA	
Output low voltage	V_{OL}	\overline{SCK} , TIMO, SO			0.4	V	$I_{OL} = 1.6$ mA	
Input/output leakage current	$ I_{IL} $	RESET, \overline{SCK} , \overline{INT}_0 , \overline{INT}_1 , SI, SO, TIMO, OSC ₁			1	μA	$V_{in} = 0$ V to V_{CC}	1
Stop mode retaining voltage	V_{STOP}	V_{CC}	2			V	Without 32-kHz oscillator	4
Current dissipation in active mode	I_{CC1}	V_{CC}		3.5	7	mA	$V_{CC} = 5$ V, $f_{OSC} = 4$ MHz	2
	I_{CC2}	V_{CC}		6	12	mA	$V_{CC} = 5$ V, $f_{OSC} = 4$ MHz	5
Current dissipation in standby mode	I_{SBY}	V_{CC}		1	2	mA	$V_{CC} = 5$ V, $f_{OSC} = 4$ MHz	3
Current dissipation in subactive mode	I_{SUB}	V_{CC}		150	300	μA	$V_{CC} = 5$ V, LCD: On	
				75	150	μA		6

HD404818 Series

Item	Symbol	Pin	Min	Typ	Max	Unit	Test Condition	Notes
Current dissipation in watch mode (1)	I_{WTC1}	V_{CC}		10	20	μA	$V_{CC} = 5\text{ V}$, LCD: Off	
Current dissipation in watch mode (2)	I_{WTC2}	V_{CC}		25	50	μA	$V_{CC} = 5\text{ V}$, LCD: On	
Current dissipation in stop mode	I_{STOP}	V_{CC}		1	10	μA	$V_{CC} = 5\text{ V}$, Without 32-kHz oscillator	

- Notes:
- Excluding output buffer current.
 - The MCU is in the reset state. Input/output current does not flow.
 - MCU in reset state
 - RESET, TEST: V_{CC}
 - The timer operates and input/output current does not flow.
 - MCU in standby mode
 - Input/output in reset state
 - Serial interface: Stop
 - RESET: GND
 - TEST: V_{CC}
 - D_{12} , D_{13} : Digital input mode
 - RAM data retention.
 - D_{12}/D_{13} is in the analog input mode.
Input/output current does not flow. $V_{C_{ref}}$, D_{12} , D_{13} : GND
 - Applies to the HD404812, HD404814, HD404816, and HD404818.

HD404818 Series

Input/Output Characteristics for Standard Pins (HD404812, HD404814, HD404816, HD404818: $V_{CC} = 4$ to 6 V; HD4074818: $V_{CC} = 4$ to 5.5 V; GND = 0 V, $T_a = -20^\circ\text{C}$ to $+75^\circ\text{C}$, unless otherwise specified)

Item	Symbol	Pin	Min	Typ	Max	Unit	Test Condition	Notes
Input high voltage	V_{IH}	D ₁₀ –D ₁₃ , R0–R3	$0.7V_{CC}$		$V_{CC} + 0.3$	V		
Input low voltage	V_{IL}	D ₁₀ –D ₁₃ , R0–R3	-0.3		$0.3V_{CC}$	V		
Output high voltage	V_{OH}	R0–R3	$V_{CC} - 1.0$			V	$-I_{OH} = 1.0$ mA	
Pull-up MOS current	$-I_{PU}$	R0–R3	30	100	180	μA	$V_{CC} = 5$ V, $V_{in} = 0$ V	
Output low voltage	V_{OL}	R0–R3			0.4	V	$I_{OL} = 1.6$ mA	
Input/output leakage current	$ I_{IL} $	D ₁₁ –D ₁₃ , R0–R3			1	μA	$V_{in} = 0$ V to V_{CC}	1
					1	μA	$V_{in} = 0$ V to V_{CC}	2
					20	μA	$V_{in} = 0$ V to V_{CC}	3
Input high voltage	V_{IHA}	D ₁₂ , D ₁₃ (analog compare mode)	$V_{C_{ref}} + 0.1$			V		
Input low voltage	V_{ILA}	D ₁₂ , D ₁₃ (analog compare mode)			$V_{C_{ref}} - 0.1$	V		
Analog input voltage	$V_{C_{ref}}$		0		$V_{CC} - 1.2$	V		

- Notes: 1. Output buffer current is excluded.
 2. Applies to HD404812, HD404814, HD404816, and HD404818.
 3. Applies to HD4074818.

HD404818 Series

Input/Output Characteristics for High-Current Pins (HD404812, HD404814, HD404816, HD404818: $V_{CC} = 4$ to 6 V; HD4074818: $V_{CC} = 4$ to 5.5 V; GND = 0 V, $T_a = -20^\circ\text{C}$ to $+75^\circ\text{C}$, unless otherwise specified)

Item	Symbol	Pin	Min	Typ	Max	Unit	Test Condition	
Input high voltage	V_{IH}	D_0 - D_9	$0.7V_{CC}$		$V_{CC} + 0.3$	V		
Input low voltage	V_{IL}	D_0 - D_9	-0.3		$0.3V_{CC}$	V		
Output high voltage	V_{OH}	D_0 - D_9	$V_{CC} - 1.0$			V	$-I_{OH} = 1.0$ mA	
Pull-up MOS current	$-I_{PU}$	D_0 - D_9	30	100	180	μA	$V_{CC} = 5$ V, $V_{in} = 0$ V	
Output low voltage	V_{OL}	D_0 - D_9				2.0	V	$I_{OL} = 15$ mA, $V_{CC} = 4.5$ to 6 V
						0.4	V	$I_{OL} = 1.6$ mA
Input/output leakage current*	$ I_{IL} $	D_0 - D_9				1	μA	$V_{in} = 0$ V to V_{CC}

Note: * Output buffer current is excluded.

Liquid Crystal Circuit Characteristics (HD404812, HD404814, HD404816, HD404818: $V_{CC} = 4$ to 6 V; HD4074818: $V_{CC} = 4$ to 5.5 V; GND = 0 V, $T_a = -20^\circ\text{C}$ to $+75^\circ\text{C}$, unless otherwise specified)

Item	Symbol	Pin	Min	Typ	Max	Unit	Test Condition	Note
Segment driver voltage drop	V_{DS}	SEG1 to SEG32			0.6	V	$I_d = 3$ μA	1
Common driver voltage drop	V_{DC}	COM1 to COM4			0.3	V	$I_d = 3$ μA	1
LCD power supply dividing resistance	R_W		100	300	900	$\text{k}\Omega$		
LCD voltage	V_{LCD}	V_1	4		V_{CC}	V		2

- Notes: 1. Voltage drops from pins V_1 , V_2 , V_3 , and GND to each segment and common pin.
2. Keep the relationship $V_{CC} \geq V_1 \geq V_2 \geq V_3 \geq \text{GND}$ when V_{LCD} is supplied by an external power supply.

HD404818 Series

AC Characteristics (HD404812, HD404814, HD404816, HD404818: $V_{CC} = 4$ to 6 V; HD4074818: $V_{CC} = 4$ to 5.5 V; $GND = 0$ V, $T_a = -20^\circ\text{C}$ to $+75^\circ\text{C}$, unless otherwise specified)

Item	Symbol	Pin	Min	Typ	Max	Unit	Test Condition	Notes
Oscillation frequency	f_{OSC}	OSC ₁ , OSC ₂	1.6	4.0	4.2	MHz		
		X1, X2		32.768		kHz		
Oscillation frequency	f_{OSC}	OSC ₁ , OSC ₂ (without 32 kHz)	0.25	4.0	4.2	MHz		
Instruction cycle time	t_{cyc}		0.95	1	2.5	μs		
			0.95	1	16		Without 32 kHz	
Oscillator stabilization time	t_{RC}	OSC ₁ , OSC ₂			30	ms	Crystal	1
					7.5	ms	Ceramic $f_{OSC} = 4$ MHz	1
		X1, X2			3	s	$T_a = -10^\circ$ to 60°C	2
External clock frequency	f_{CP}	OSC ₁	1.6		4.2	MHz		3
			0.25		4.2	MHz	Without 32 kHz	3
External clock high width	t_{CPH}	OSC ₁	110			ns		3
External clock low width	t_{CPL}	OSC ₁	110			ns		3
External clock rise time	t_{CPr}	OSC ₁			20	ns		3
External clock fall time	t_{CPf}	OSC ₁			20	ns		3
$\overline{\text{INT}}_0$ high width	t_{IH}	$\overline{\text{INT}}_0$	2			$t_{cyc}/$ t_{subcyc}		4, 6
$\overline{\text{INT}}_0$ low width	t_{IL}	$\overline{\text{INT}}_0$	2			$t_{cyc}/$ t_{subcyc}		4, 6
$\overline{\text{INT}}_1$ high width	t_{IH}	$\overline{\text{INT}}_1$	2			t_{cyc}		4
$\overline{\text{INT}}_1$ low width	t_{IL}	$\overline{\text{INT}}_1$	2			t_{cyc}		4

HD404818 Series

Item	Symbol	Pin	Min	Typ	Max	Unit	Test Condition	Notes
RESET high width	t_{RSTH}	RESET	2			t_{cyc}		5
Input capacitance	C_{in}	D ₁₀			15	pF	f = 1 MHz, V _{in} = 0 V	8
					90	pF	f = 1 MHz, V _{in} = 0 V	9
		All pins except D ₁₀			15	pF	f = 1 MHz, V _{in} = 0 V	
RESET fall time	t_{RSTF}				20	ms		5
Analog comparator stabilization time	t_{CSTB}	D ₁₂ , D ₁₃			2	t_{cyc}		7

- Notes:
1. The oscillator stabilization time is the period up until the time the oscillator stabilizes after V_{CC} reaches 4.0 V at power-on, or after RESET goes high. At power-on or stop mode release, RESET must be kept high for at least t_{RC}. Since t_{RC} depends on the ceramic oscillator's circuit constant and stray capacitance, consult with the manufacturer when designing the reset circuit.
 2. The oscillator stabilization time is the period up until the time the oscillator stabilizes after V_{CC} reaches 4.0 V at power-on. The time required to stabilize the oscillator (t_{RC}) must be obtained. Since t_{RC} depends on the crystal circuit constant and stray capacitance, consult with the manufacturer.
 3. See figure 43.
 4. See figure 44. The unit t_{cyc} is applied when the MCU is in standby mode or active mode.
 5. See figure 45.
 6. See figure 44. The unit t_{subcyc} is applied when the MCU is in watch mode or subactive mode. t_{subcyc} = 244.14 μs (when a 32.768-kHz crystal oscillator is used)
 7. The analog comparator stabilization time is the period up until the analog comparator stabilizes and correct data can be read after placing D₁₂/D₁₃ into analog input mode.
 8. Applies to HD404812, HD404814, HD404816, and HD404818.
 9. Applies to HD4074818.

Serial Interface Timing Characteristics

During Transmit Clock Output (HD404812, HD404814, HD404816, HD404818: $V_{CC} = 4$ to 6 V; HD4074818: $V_{CC} = 4$ to 5.5 V; $GND = 0$ V, $T_a = -20^{\circ}\text{C}$ to $+75^{\circ}\text{C}$, unless otherwise specified)

Item	Symbol	Pin	Min	Typ	Max	Unit	Test Condition	Notes
Transmit clock cycle time	$t_{S_{cyc}}$	\overline{SCK}	1			$t_{cyc}/$ t_{subcyc}		1, 2, 4
Transmit clock high and low widths	t_{SCKH}, t_{SCKL}	\overline{SCK}	0.5			$t_{S_{cyc}}$		1, 2
Transmit clock rise and fall times	t_{SCKr}, t_{SCKf}	\overline{SCK}			100	ns		1, 2
Serial output data delay time	t_{DSO}	SO			300	ns		1, 2
Serial input data setup time	t_{SSI}	SI	200			ns		1
Serial input data hold time	t_{HSI}	SI	150			ns		1

During Transmit Clock Input

Item	Symbol	Pin	Min	Typ	Max	Unit	Test Condition	Notes
Transmit clock cycle time	$t_{S_{cyc}}$	\overline{SCK}	1			$t_{cyc}/$ t_{subcyc}		1, 4
Transmit clock high and low widths	t_{SCKH}, t_{SCKL}	\overline{SCK}	0.5			$t_{S_{cyc}}$		1
Transmit clock rise and fall times	$t_{SCKr},$ t_{SCKf}	\overline{SCK}			100	ns		1
Serial output data delay time	t_{DSO}	SO			300	ns		1, 2
Serial input data setup time	t_{SSI}	SI	200			ns		1
Serial input data hold time	t_{HSI}	SI	150			ns		1
Transmit clock completion detect time	t_{SCKHD}	\overline{SCK}	1			$t_{cyc}/$ t_{subcyc}		1,2, 3, 4

- Notes:
1. See figure 46.
 2. See figure 47.
 3. The transmit clock completion detect time is the high level period after 8 pulses of transmit clocks are input. The serial interrupt request flag is not set if the next transmit clock is input before the transmit clock completion detect time has passed.
 4. The unit t_{subcyc} is applied when the MCU is in subactive mode. $t_{subcyc} = 244.14 \mu\text{s}$ (for a 32.768-kHz crystal oscillator).

HD404818 Series

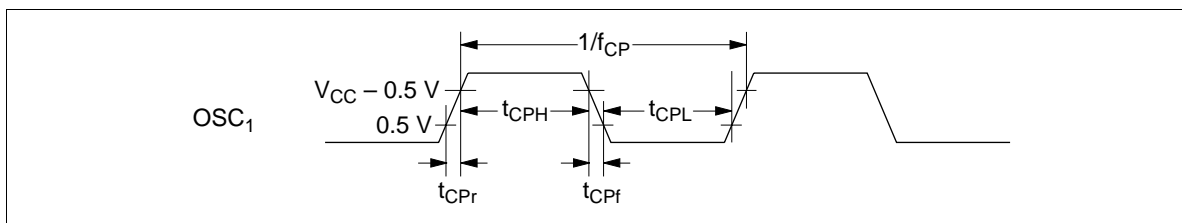

Figure 43 Oscillator Timing

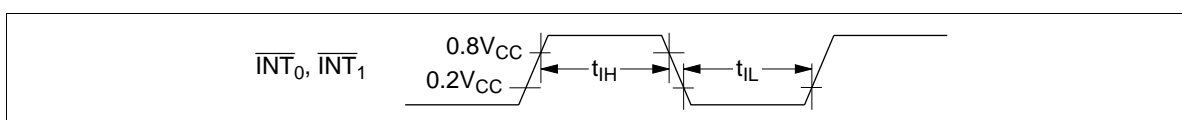

Figure 44 Interrupt Timing

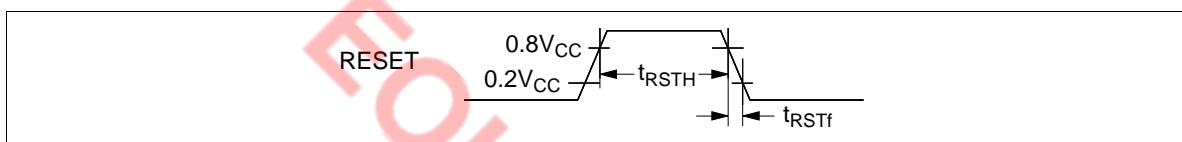

Figure 45 Reset Timing

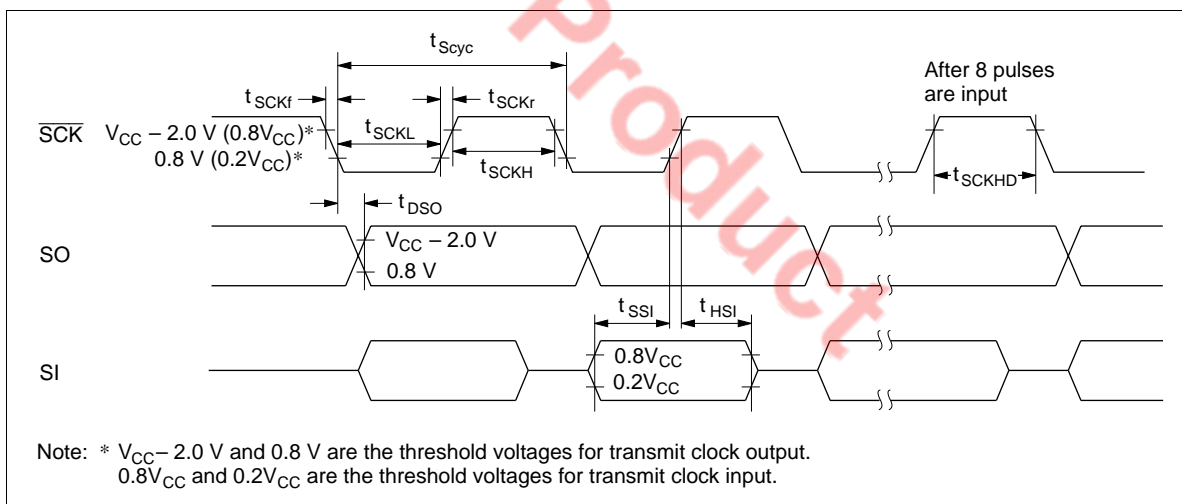

Figure 46 Serial Interface Timing

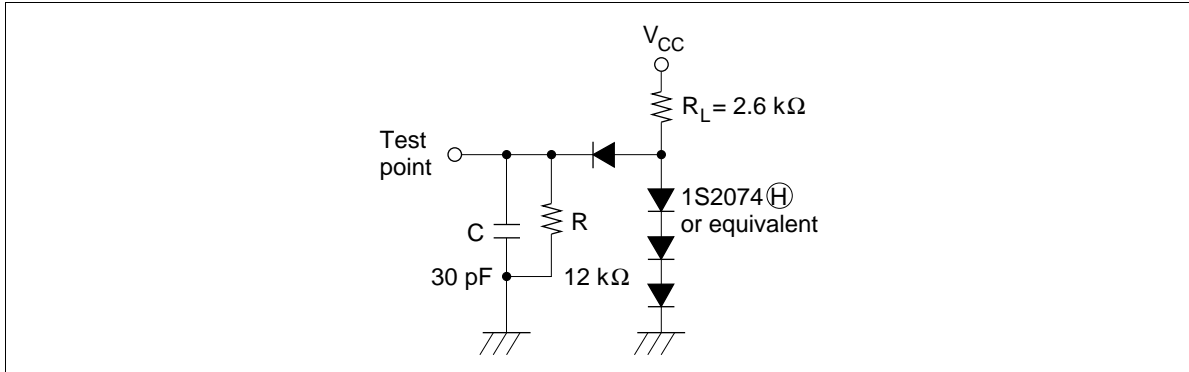

Figure 47 Timing Load Circuit

EOL Product

HD404818 Series

Electrical Characteristics for Low-Voltage Versions

HD40L4812, HD40L4814, HD40L4816, HD40L4818, and HD407L4818 Electrical Characteristics

DC Characteristics (HD40L4812, HD40L4814, HD40L4816, HD40L4818: $V_{CC} = 2.7$ to 6 V; HD407L4818: $V_{CC} = 3$ to 5.5 V; $GND = 0$ V, $T_a = -20^{\circ}\text{C}$ to $+75^{\circ}\text{C}$, unless otherwise specified)

Item	Symbol	Pin	Min	Typ	Max	Unit	Test Condition	Notes
Input high voltage	V_{IH}	RESET, \overline{SCK} , \overline{INT}_0 , SI, \overline{INT}_1	$0.9V_{CC}$		$V_{CC} + 0.3$	V		
		OSC ₁	$V_{CC} - 0.3$		$V_{CC} + 0.3$	V		
Input low voltage	V_{IL}	RESET, \overline{SCK} , \overline{INT}_0 , SI, \overline{INT}_1	-0.3		$0.1V_{CC}$	V		
		OSC ₁	-0.3		0.3	V		
Output high voltage	V_{OH}	\overline{SCK} , TIMO, SO	$V_{CC} - 1.0$			V	$-I_{OH} = 0.5$ mA	
Output low voltage	V_{OL}	\overline{SCK} , TIMO, SO			0.4	V	$I_{OL} = 0.4$ mA	
Input/output leakage current	$ I_{IL} $	RESET, \overline{SCK} , \overline{INT}_0 , \overline{INT}_1 , SI, SO, TIMO, OSC ₁			1	μA	$V_{in} = 0$ V to V_{CC}	1
Stop mode retaining voltage	V_{STOP}	V_{CC}	2			V	Without 32-kHz oscillator	4
Current dissipation in active mode	I_{CC1}	V_{CC}		400	1000	μA	$V_{CC} = 3$ V, $f_{OSC} = 400$ kHz	2
	I_{CC2}	V_{CC}		1	2	mA	$V_{CC} = 3$ V, $f_{OSC} = 400$ kHz, analog input mode (D_{12}/D_{13})	5
Current dissipation in standby mode	I_{SBY}	V_{CC}		200	500	μA	$V_{CC} = 3$ V, $f_{OSC} = 400$ kHz	3
Current dissipation in subactive mode	I_{SUB}	V_{CC}		50	100	μA	$V_{CC} = 3$ V, LCD: On	
				35	70	μA		6

HD404818 Series

Item	Symbol	Pin	Min	Typ	Max	Unit	Test Condition	Notes
Current dissipation in watch mode (1)	I_{WTC1}	V_{CC}		5	15	μA	$V_{CC} = 3\text{ V}$, LCD: Off	
Current dissipation in watch mode (2)	I_{WTC2}	V_{CC}		15	35	μA	$V_{CC} = 3\text{ V}$, LCD: On	
Current dissipation in stop mode	I_{STOP}	V_{CC}		1	10	μA	$V_{CC} = 3\text{ V}$, Without 32-kHz oscillator	

- Notes:
1. Excluding output buffer current.
 2. The MCU is in the reset state. Input/output current does not flow.
 - MCU in reset state
 - RESET, $\overline{\text{TEST}}$: V_{CC}
 3. The timer operates and input/output current does not flow.
 - MCU in standby mode
 - Input/output in reset state
 - Serial interface: Stop
 - RESET: GND
 - $\overline{\text{TEST}}$: V_{CC}
 - D_0 – D_{13} , R0–R3: V_{CC}
 - D_{12} , D_{13} : Digital input mode
 4. RAM data retention.
 5. D_{12}/D_{13} is in the analog input mode.
Input/output current does not flow. $V_{C_{ref}}$, D_{12} , D_{13} : GND
 6. Applies to HD40L4812, HD40L4814, HD40L4816, and HD40L4818.

HD404818 Series

Input/Output Characteristics for Standard Pins (HD40L4812, HD40L4814, HD40L4816, HD40L4818: $V_{CC} = 2.7$ to 6 V; HD407L4818: $V_{CC} = 3$ to 5.5 V; GND = 0 V, $T_a = -20^\circ\text{C}$ to $+75^\circ\text{C}$, unless otherwise specified)

Item	Symbol	Pin	Min	Typ	Max	Unit	Test Condition	Notes
Input high voltage	V_{IH}	D ₁₀ –D ₁₃ , R0–R3	$0.7V_{CC}$		$V_{CC} + 0.3$	V		
Input low voltage	V_{IL}	D ₁₀ –D ₁₃ , R0–R3	-0.3		$0.3V_{CC}$	V		
Output high voltage	V_{OH}	R0–R3	$V_{CC} - 1.0$			V	$-I_{OH} = 0.5$ mA	
Pull-up MOS current	$-I_{PU}$	R0–R3	5	40	90	μA	$V_{CC} = 3$ V, $V_{in} = 0$ V	
Output low voltage	V_{OL}	R0–R3			0.4	V	$I_{OL} = 0.4$ mA	
Input/output leakage current	$ I_{IL} $	D ₁₁ –D ₁₃ , R0–R3			1	μA	$V_{in} = 0$ V to V_{CC}	1
		D ₁₀			1	μA	$V_{in} = 0$ V to V_{CC}	2
					20	μA	$V_{in} = 0$ V to V_{CC}	3
Input high voltage	V_{IHA}	D ₁₂ , D ₁₃ (Analog compare mode)	$V_{Cref} + 0.1$			V		
Input low voltage	V_{ILA}	D ₁₂ , D ₁₃ (Analog compare mode)			$V_{Cref} - 0.1$	V		
Analog input voltage	V_{Cref}		0		$V_{CC} - 1.2$	V		

- Notes: 1 Output buffer current is excluded.
 2 Applies to HD40L4812, HD40L4814, HD40L4816, and HD40L4818.
 3 Applies to HD407L4818.

HD404818 Series

Input/Output Characteristics for High-Current Pins (HD40L4812, HD40L4814, HD40L4816, HD40L4818: $V_{CC} = 2.7$ to 6 V; HD407L4818: $V_{CC} = 3$ to 5.5 V; GND = 0 V, $T_a = -20^\circ\text{C}$ to $+75^\circ\text{C}$, unless otherwise specified)

Item	Symbol	Pin	Min	Typ	Max	Unit	Test Condition	
Input high voltage	V_{IH}	D_0 - D_9	$0.7V_{CC}$		$V_{CC} + 0.3$	V		
Input low voltage	V_{IL}	D_0 - D_9	-0.3		$0.3V_{CC}$	V		
Output high voltage	V_{OH}	D_0 - D_9	$V_{CC} - 1.0$			V	$-I_{OH} = 0.5$ mA	
Pull-up MOS current	$-I_{PU}$	D_0 - D_9	5	40	90	μA	$V_{CC} = 3$ V, $V_{in} = 0$ V	
Output low voltage	V_{OL}	D_0 - D_9				2.0	V	$I_{OL} = 15$ mA, $V_{CC} = 4.5$ to 6 V
						0.4	V	$I_{OL} = 0.4$ mA
Input/output leakage current*	$ I_{IL} $	D_0 - D_9				1	μA	$V_{in} = 0$ V - V_{CC}

Note: *Output buffer current is excluded.

Liquid Crystal Circuit Characteristics (HD40L4812, HD40L4814, HD40L4816, HD40L4818: $V_{CC} = 2.7$ to 6 V; HD407L4818: $V_{CC} = 3$ to 5.5 V; GND = 0 V, $T_a = -20^\circ\text{C}$ to $+75^\circ\text{C}$, unless otherwise specified)

Item	Symbol	Pin	Min	Typ	Max	Unit	Test Condition	Notes
Segment driver voltage drop	V_{DS}	SEG1 to SEG32			0.6	V	$I_d = 3$ μA	1
Common driver voltage drop	V_{DC}	COM1 to COM4			0.3	V	$I_d = 3$ μA	1
LCD power supply dividing resistance	R_W		100	300	900	$k\Omega$		
LCD voltage	V_{LCD}	V_1	2.7		V_{CC}	V		2, 3

- Notes:
1. Voltage drops from pins V_1 , V_2 , V_3 , and GND to each segment and common pin.
 2. Keep the relation $V_{CC} \geq V_1 \geq V_2 \geq V_3 \geq \text{GND}$ when V_{LCD} is supplied by an external power supply.
 3. V_{LCD} min. = 2.7 V (HD40L4812, HD40L4814, HD40L4816, HD40L4818)
 V_{LCD} min. = 3 V (HD407L4818)

HD404818 Series

AC Characteristics (HD40L4812, HD40L4814, HD40L4816, HD40L4818: $V_{CC} = 2.7$ to 6 V; HD407L4818: $V_{CC} = 3$ to 5.5 V; $GND = 0$ V, $T_a = -20^\circ\text{C}$ to $+75^\circ\text{C}$, unless otherwise specified)

Item	Symbol	Pin(s)	Min	Typ	Max	Unit	Test Condition	Notes
Oscillation frequency	f_{OSC}	OSC ₁ , OSC ₂	250	800	900	kHz		
		X1, X2		32.768		kHz		
Instruction cycle time	t_{cyc}		4.45	5	16	μs		
Oscillator stabilization time	t_{RC}	OSC ₁ , OSC ₂			7.5	ms	$f_{OSC} = 400$ kHz	1
					7.5	ms	$f_{OSC} = 800$ kHz	1
		X1, X2			3	s	$T_a = -10^\circ$ to 60°C	2
External clock frequency	f_{CP}	OSC ₁	250		900	kHz		3
External clock high width	t_{CPH}	OSC ₁	525			ns		3
External clock low width	t_{CPL}	OSC ₁	525			ns		3
External clock rise time	t_{CPr}	OSC ₁			30	ns		3
External clock fall time	t_{CPf}	OSC ₁			30	ns		3
\overline{INT}_0 high width	t_{IH}	\overline{INT}_0	2			$t_{cyc}/$ t_{subcyc}		4, 6
\overline{INT}_0 low width	t_{IL}	\overline{INT}_0	2			$t_{cyc}/$ t_{subcyc}		4, 6
\overline{INT}_1 high width	t_{IH}	\overline{INT}_1	2			t_{cyc}		4
\overline{INT}_1 low width	t_{IL}	\overline{INT}_1	2			t_{cyc}		4
RESET high width	t_{RSTH}	RESET	2			t_{cyc}		5
Input capacitance	C_{in}	D ₁₀			15	pF	$f = 1$ MHz, $V_{in} = 0$ V	8
					90	pF	$f = 1$ MHz, $V_{in} = 0$ V	9
		All pins except D ₁₀		15	pF	$f = 1$ MHz, $V_{in} = 0$ V		
Reset fall time	t_{RSTf}				20	ms		5
Analog comparator stabilization time	t_{CSTB}	D ₁₂ , D ₁₃			2	t_{cyc}		7

Notes: 1. The oscillator stabilization time is the period from when V_{CC} reaches 2.7 V (HD407L4818: $V_{CC} = 3.0$ V) at power-on until the oscillator stabilizes, or after RESET goes high. At power-on or when recovering from stop mode, RESET must be kept high for more than t_{RC} . Since t_{RC} depends on the ceramic oscillator's circuit constant and stray capacitance, consult with the ceramic oscillator manufacturer when designing the reset circuit.

2. The oscillator stabilization time is the period from when V_{CC} reaches 2.7 V (HD407L4818: $V_{CC} = 3.0$ V) at power-on until the oscillator stabilizes. The time required to stabilize the oscillator (t_{RC}) must be obtained. Since t_{RC} depends on the ceramic oscillator's circuit constant and stray capacitance, consult with the ceramic oscillator manufacturer.
3. See figure 48.
4. See figure 49. The unit t_{cyc} is applied when the MCU is in standby mode or active mode.
5. See figure 50.
6. See figure 49. The unit t_{subcyc} is applied when the MCU is in watch mode or subactive mode. $t_{subcyc} = 244.14 \mu s$ (when a 32.768-kHz crystal oscillator is used)
7. The analog comparator stabilization time is the period from when D_{12}/D_{13} is placed in analog input mode until the analog comparator stabilizes and correct data can be read.
8. Applies to HD40L4812, HD40L4814, HD40L4816, and HD40L4818.
9. Applies to HD407L4818.

Serial Interface Timing Characteristics

During Transmit Clock Output (HD40L4812, HD40L4814, HD40L4816, HD40L4818: $V_{CC} = 2.7$ to 6 V; HD407L4818: $V_{CC} = 3$ to 5.5 V; GND = 0 V, $T_a = -20^\circ C$ to $+75^\circ C$, unless otherwise specified)

Item	Symbol	Pin(s)	Min	Typ	Max	Unit	Test Condition	Notes
Transmit clock cycle time	t_{Scyc}	\overline{SCK}	1			$t_{cyc}/$ t_{subcyc}		1, 2, 4
Transmit clock high and low widths	$t_{SCKH},$ t_{SCKL}	\overline{SCK}	0.5			t_{Scyc}		1, 2
Transmit clock rise and fall times	$t_{SCKr},$ t_{SCKf}	\overline{SCK}			200	ns		1, 2
Serial output data delay time	t_{DSO}	SO			500	ns		1, 2
Serial input data setup time	t_{SSI}	SI	300			ns		1
Serial input data hold time	t_{HSI}	SI	300			ns		1

HD404818 Series

During Transmit Clock Input

Item	Symbol	Pin(s)	Min	Typ	Max	Unit	Test Condition	Notes
Transmit clock cycle time	$t_{S_{cyc}}$	\overline{SCK}	1			$t_{cyc}/$ t_{subcyc}		1, 4
Transmit clock high and low widths	t_{SCKH} , t_{SCKL}	\overline{SCK}	0.5			$t_{S_{cyc}}$		1
Transmit clock rise and fall times	t_{SCKr} , t_{SCKf}	\overline{SCK}			200	ns		1
Serial output data delay time	t_{DSO}	SO			500	ns		1, 2
Serial input data setup time	t_{SSI}	SI	300			ns		1
Serial input data hold time	t_{HSI}	SI	300			ns		1
Transmit clock completion detect time	t_{SCKHD}	\overline{SCK}	1			$t_{cyc}/$ t_{subcyc}		1, 2, 3, 4

- Notes:
- See figure 51.
 - See figure 52.
 - The transmit clock completion detect time is the high level period after 8 pulses of transmit clocks are input. The serial interrupt request flag is not set if the next transmit clock is input before the transmit clock completion detect time has passed.
 - t_{subcyc} is applied when the MCU is in subactive mode. $t_{subcyc} = 244.14 \mu s$ (for a 32.768-kHz crystal oscillator).

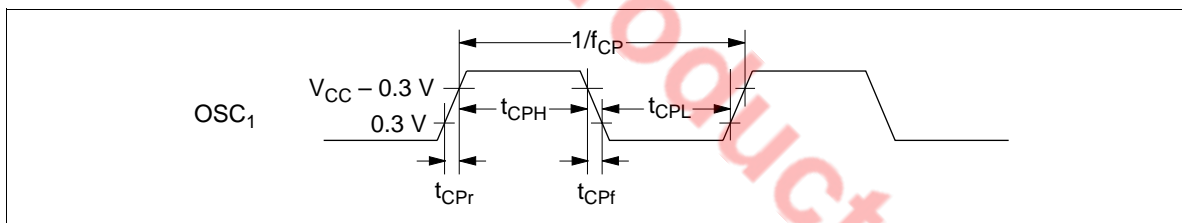

Figure 48 Oscillator Timing

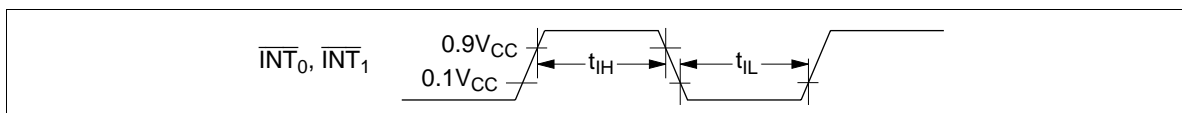

Figure 49 Interrupt Timing

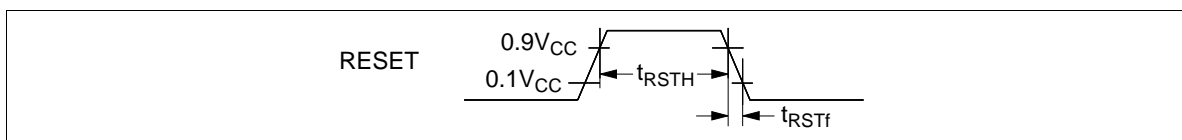

Figure 50 Reset Timing

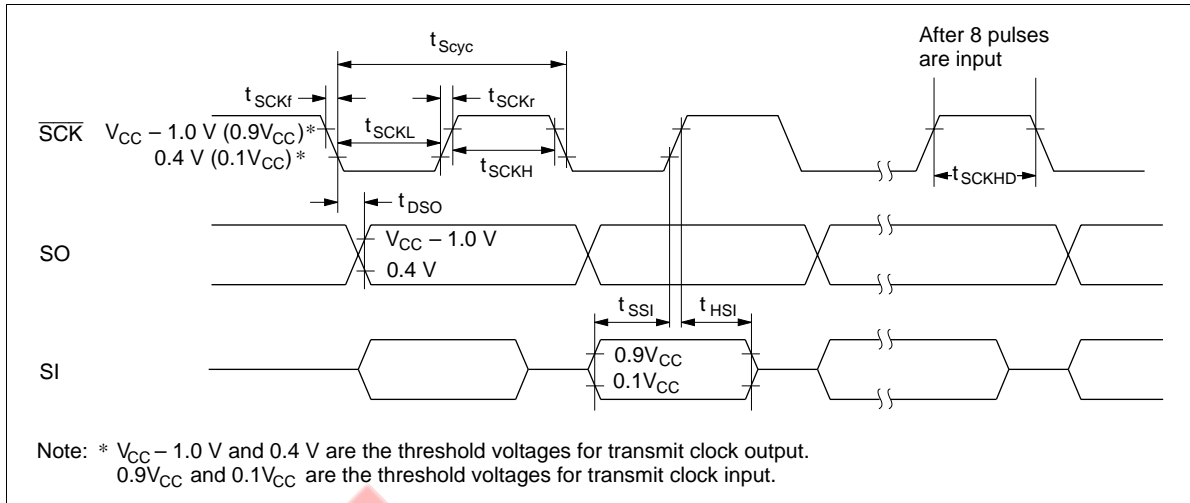

Figure 51 Timing of Serial Interface

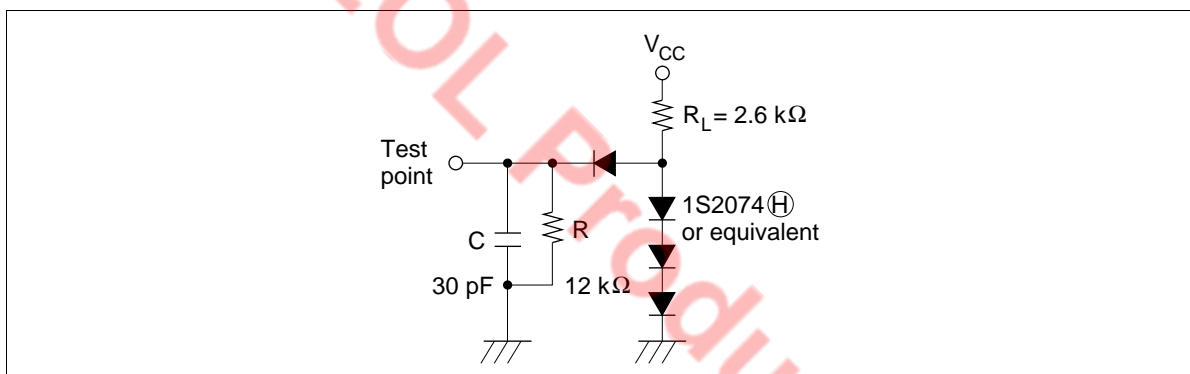

Figure 52 Timing Load Circuit

HD404818 Series

HD404812, HD404814, HD404816, HD404818, HD40L4812, HD40L4814, HD40L4816, HD40L4818 Option List

Please check off the appropriate applications and enter the necessary information.

1. ROM Size

<input type="checkbox"/> 5-V operation	HD404812	2-kword
<input type="checkbox"/> Low-voltage operation	HD40L4812	
<input type="checkbox"/> 5-V operation	HD404814	4-kword
<input type="checkbox"/> Low-voltage operation	HD40L4814	
<input type="checkbox"/> 5-V operation	HD404816	6-kword
<input type="checkbox"/> Low-voltage operation	HD40L4816	
<input type="checkbox"/> 5-V operation	HD404818	8-kword
<input type="checkbox"/> Low-voltage operation	HD40L4818	

Date of order	/ /
Customer	
Department	
Name	
ROM code name	
LSI type number (Hitachi's entry)	

2. Optional Functions

* <input type="checkbox"/> With 32-kHz CPU operation and with watch time base
* <input type="checkbox"/> Without 32-kHz CPU operation and with watch time base
<input type="checkbox"/> Without 32-kHz CPU operation and without watch time base

Note: * Options marked with an asterisk require a subsystem crystal oscillator (X1, X2).

3. ROM Code Media

Please specify the first type below (the upper bits and lower bits are mixed together), when using the EPROM on-package microcomputer type (including ZTAT™ version).

<input type="checkbox"/> EPROM: The upper bits and lower bits are mixed together. The upper five bits and lower five bits are programmed to the same EPROM in alternating order (i.e., LULULU...).
<input type="checkbox"/> EPROM: The upper bits and lower bits are separated. The upper five bits and lower five bits are programmed to different EPROMs.

4. Oscillator

<input type="checkbox"/> Ceramic oscillator	f =	MHz
<input type="checkbox"/> Crystal oscillator	f =	MHz
<input type="checkbox"/> External clock	f =	MHz

5. Stop mode

<input type="checkbox"/> Used
<input type="checkbox"/> Not used

6. Package

<input type="checkbox"/> FP-80A
<input type="checkbox"/> FP-80B
<input type="checkbox"/> TFP-80

HD404818 Series

Cautions

1. Hitachi neither warrants nor grants licenses of any rights of Hitachi's or any third party's patent, copyright, trademark, or other intellectual property rights for information contained in this document. Hitachi bears no responsibility for problems that may arise with third party's rights, including intellectual property rights, in connection with use of the information contained in this document.
2. Products and product specifications may be subject to change without notice. Confirm that you have received the latest product standards or specifications before final design, purchase or use.
3. Hitachi makes every attempt to ensure that its products are of high quality and reliability. However, contact Hitachi's sales office before using the product in an application that demands especially high quality and reliability or where its failure or malfunction may directly threaten human life or cause risk of bodily injury, such as aerospace, aeronautics, nuclear power, combustion control, transportation, traffic, safety equipment or medical equipment for life support.
4. Design your application so that the product is used within the ranges guaranteed by Hitachi particularly for maximum rating, operating supply voltage range, heat radiation characteristics, installation conditions and other characteristics. Hitachi bears no responsibility for failure or damage when used beyond the guaranteed ranges. Even within the guaranteed ranges, consider normally foreseeable failure rates or failure modes in semiconductor devices and employ systemic measures such as fail-safes, so that the equipment incorporating Hitachi product does not cause bodily injury, fire or other consequential damage due to operation of the Hitachi product.
5. This product is not designed to be radiation resistant.
6. No one is permitted to reproduce or duplicate, in any form, the whole or part of this document without written approval from Hitachi.
7. Contact Hitachi's sales office for any questions regarding this document or Hitachi semiconductor products.