

THE INFORMATION CONTAINED HEREIN IS CONSIDERED "PROPRIETARY" TO BEL FUSE INC. AND SHALL NOT BE COPIED, REPRODUCED OR DISCLOSED WITHOUT THE WRITTEN APPROVAL OF BEL FUSE INC.

RoHS



ELECTRICAL CHARACTERISTICS @ 25°C

- 1.0 TURNS RATIO: (P4-P5-P6) : (J3-J6) : 1CT : 1CT ± 3%
(P3-P2-P1) : (J2-J1) : 1CT : 1CT ± 3%
- 2.0 INDUCTANCE: (P4-P6) : 350uH MIN. @ 0.1V, 100KHz, 8mA DC Bias
(P3-P1) : 350uH MIN. @ 0.1V, 100KHz, 8mA DC Bias
- 3.0 LEAKAGE INDUCTANCE: P6-P4 (WITH J6 AND J3 SHORT) : 0.3uH MAX. @ 1MHz
P3-P1 (WITH J2 AND J1 SHORT) : 0.3uH MAX. @ 1MHz
- 4.0 INTERWINDING CAPACITANCE: (P6,P5,P4) TO (J6,J3) : 30pF MAX @ 1MHz
(P3,P2,P1) TO (J2,J1) : 30pF MAX. @ 1MHz
- 5.0 DC RESISTANCE: (J6-J3)=(J2-J1) : 1.35 ohms Max.
- 6.0 RETURN LOSS:(P4-P6)=100 OHMS AND (P1-P3)=100 OHM REF.
1MHz TO 30MHz : 18dB MIN.
60MHz TO 80MHz : 12dB MIN.
NOTE: 100 OHMS CONNECTED TO (J2-J1) OR (J3-J6).
- 7.0 DIELECTRIC WITHSTAND: (J1, J2) TO (P1, P3) : 1500 Vrms
(J3, J6) TO (P4, P6) : 1500 Vrms
- 8.0 INSERTION LOSS: RS=RL=100 ohms
100KHz TO 100MHz : 1.1 dB TYP
- 9.0 RISE TIME: RS=100 OHMS AND RL = 100 OHMS
OUTPUT VOLTAGE = 1 V peak : 3.0 nS MAX
PULSE WIDTH= 112nS : 3.0 nS MAX
- 10.0 CROSS TALK: 1-100 MHz : 40 dB TYP
- 11.0 COMMON TO COMMON MODE ATTENUATION: 30MHz TO 100MHz : 35dB TYP

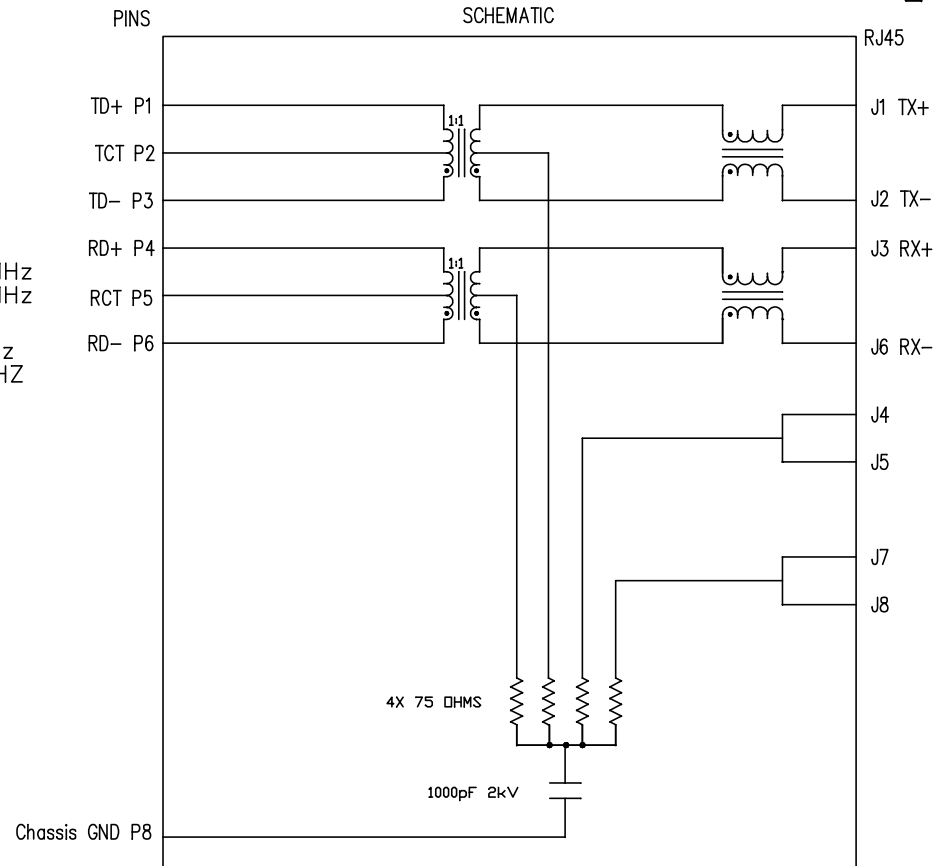

NOTES: 1.0 UNUSED PIN P7 IS OMITTED.

ORIGINATED BY CHOW WANCHUNG DATE 2018-01-31		TITLE 10/100BT MagJack® TAB UP, SHIELDED	PART NO. / DRAWING NO. SI-50170-F		STANDARD DIM. TOL. IN INCH		[] METRIC DIM. AS REF.		REV. : B	PAGE : 2
DRAWN BY XIE YIMING DATE 2018-01-31			FILE NAME SI-50170-F_B.DWG		.X	.XX	.XXX	UNIT : INCH [mm] SCALE : N/A SIZE : A4		

DC002(2)120214

This document is electronically generated. This is a controlled copy if used internally

THE INFORMATION CONTAINED HEREIN IS CONSIDERED 'PROPRIETARY' TO BEL FUSE INC. AND SHALL NOT BE COPIED, REPRODUCED OR DISCLOSED WITHOUT THE WRITTEN APPROVAL OF BEL FUSE INC.



NOTES:

- CONNECTOR MATERIALS:
 HOUSING: THERMOPLASTIC UL94 V-0
 CONTACT/SHIELD: COPPER ALLOY
 SHIELD PLATING: NICKEL OR TIN
 CONTACT PLATING: 50 MICRO-INCH SELECTIVE HARD GOLD PLATING OR EQUIVALENT IN CONTACT AREA
- PIN NOT ELECTRICALLY CONNECTED MAYBE OMITTED. SEE ELECTRICAL DRAWING FOR OMITTED PINS.
- TOLERANCES COMPLY WITH F.C.C. DIMENSION REQUIREMENTS.
- ALL TOLERANCES NOT OTHERWISE SPECIFIED TO BE ± 0.005 [0.13]
- THE PRODUCT IS RoHS COMPLIANT.
- THE PART IS RECOMMENDED FOR WAVE SOLDERING. THE SUGGESTED PEAK WAVE SOLDERING CONDITION IS 260°C MAX AND 10 SECONDS MAX.

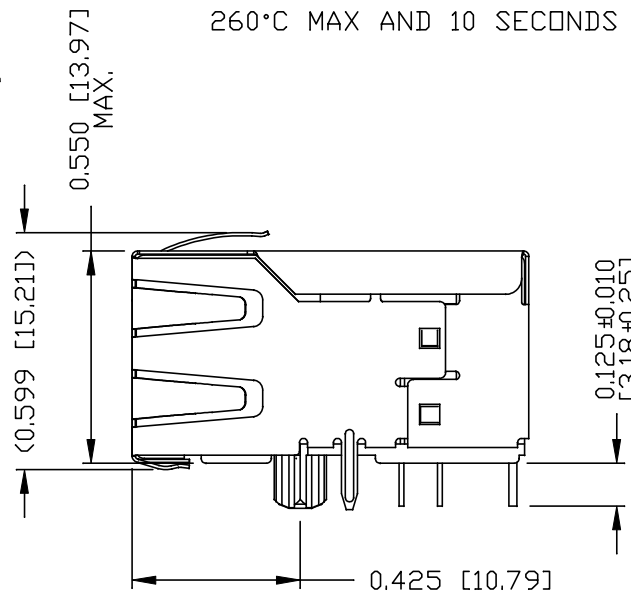
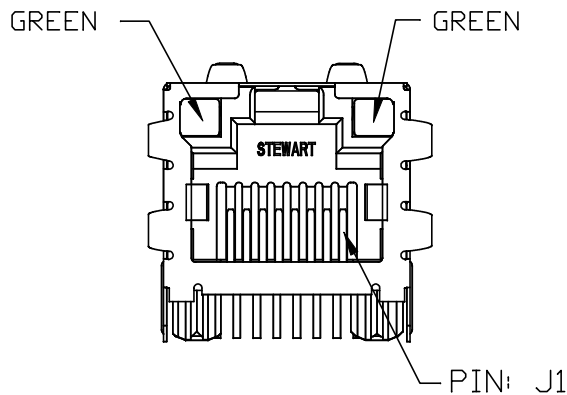
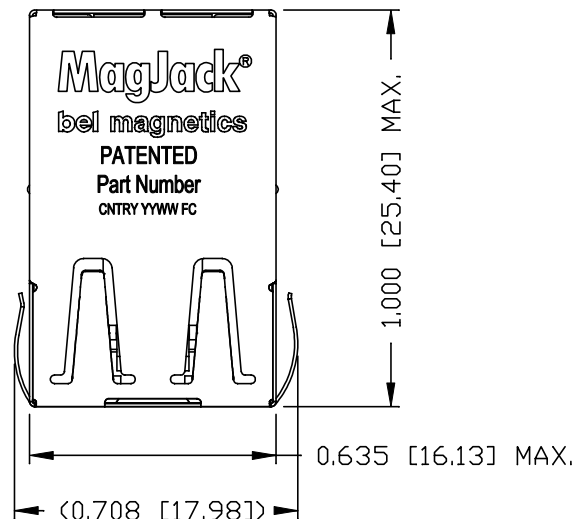

ORIGINATED BY
ANTON LIAO
DATE 2018-01-31
DRAWN BY
LIU DONGJUN
DATE 2018-01-31

TITLE
10/100BT MagJack®
TAB UP, SHIELDED

PART NO. / DRAWING NO.
SI-50170-F
FILE NAME
SI-50170-F_B.DWG

STANDARD DIM. TOL. IN INCH		[] METRIC DIM. AS REF.	
.X		UNIT : INCH [mm]	
.XX		SCALE : N/A	
.XXX	± 0.005		SIZE : A4

REV. : B PAGE : 3



THE INFORMATION CONTAINED HEREIN IS CONSIDERED "PROPRIETARY" TO BEL FUSE INC. AND SHALL NOT BE COPIED, REPRODUCED OR DISCLOSED WITHOUT THE WRITTEN APPROVAL OF BEL FUSE INC.

RoHS



LED SPECIFICATION			
STANDARD LED	WAVELENGTH	FORWARD V (MAX)	*(TYP)
GREEN	565 nm	2.5 V	2.2 V

*WITH A FORWARD CURRENT OF 20 mA (TYP)

LED POLARITY

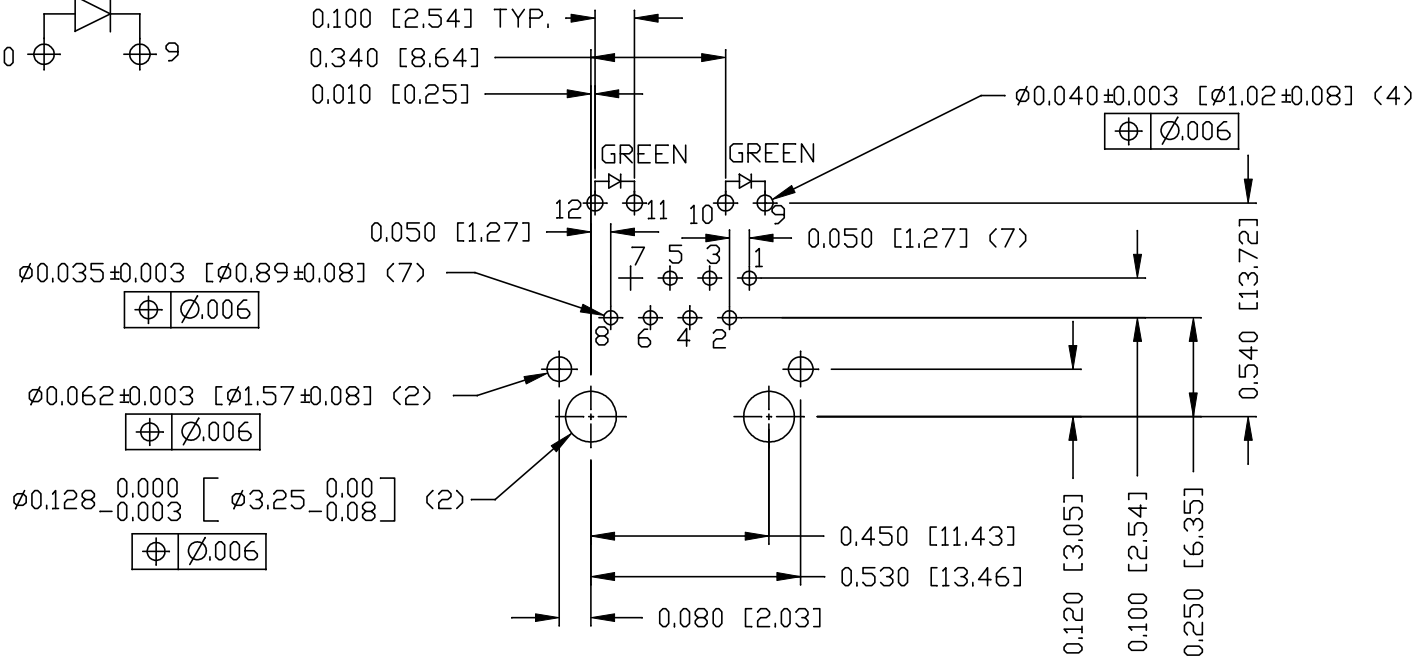
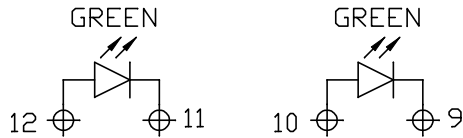

P.C.B. RECOMMENDED HOLE LAYOUT
SEEN FROM COMPONENT SIDE

ALL CENTERLINE DIMENSIONS ARE BASIC

REV. : B PAGE : 4

ORIGINATED BY
ANTON LIAO
DATE 2018-01-31
DRAWN BY
LIU DONGJUN
DATE 2018-01-31

TITLE
10/100BT MagJack®
TAB UP, SHIELDED

PART NO. / DRAWING NO.
SI-50170-F
FILE NAME
SI-50170-F_B.DWG

STANDARD DIM. TOL. IN INCH	[] METRIC DIM. AS REF.
.X	UNIT : INCH [mm]
.XX	SCALE : N/A
.XXX	SIZE : A4



THE INFORMATION CONTAINED HEREIN IS CONSIDERED "PROPRIETARY" TO BEL FUSE INC. AND SHALL NOT BE COPIED, REPRODUCED OR DISCLOSED WITHOUT THE WRITTEN APPROVAL OF BEL FUSE INC.

RoHS

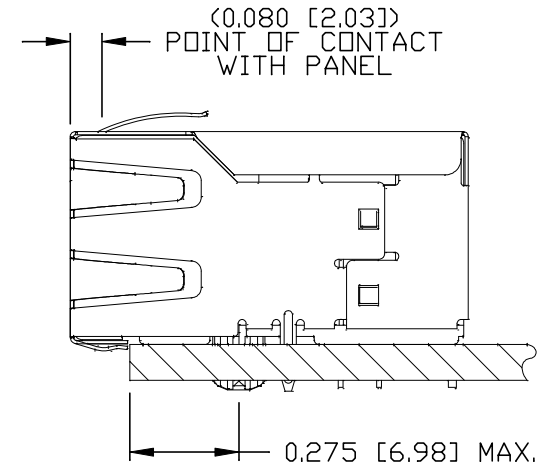
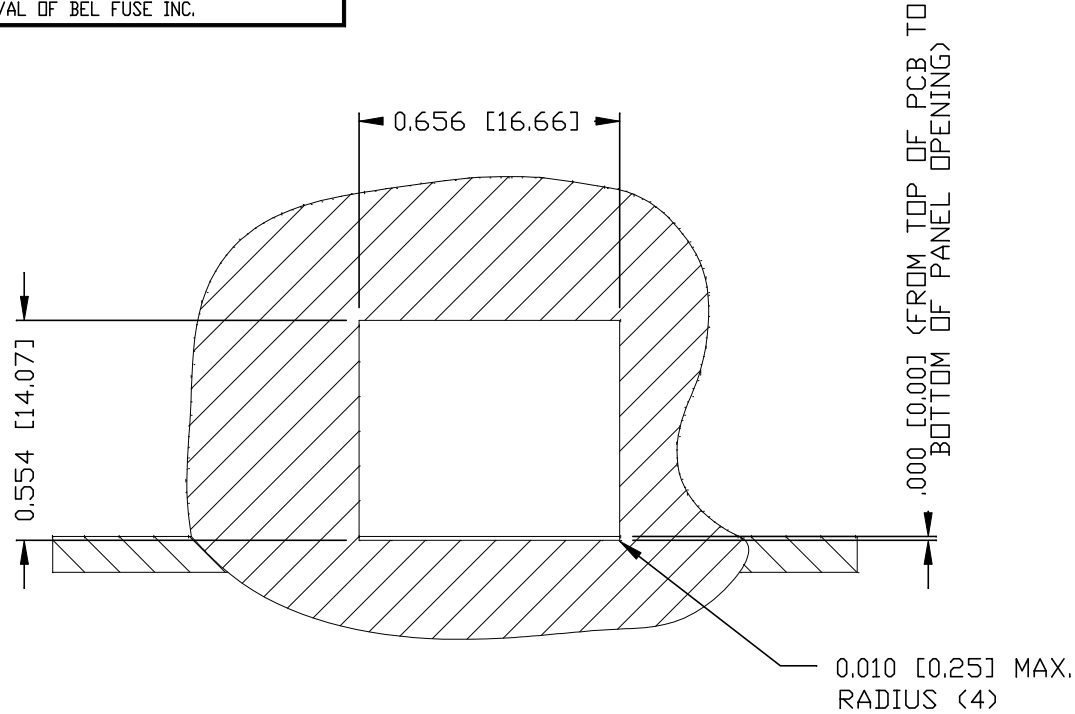

SUGGESTED PANEL OPENING

NOTES:

THE SUGGESTED PANEL OPENING IS INTENDED TO GIVE THE USER THE ABILITY TO HAVE REASONABLE JACK / PANEL CLEARANCES YET MAINTAIN RELIABLE GROUNDING CAPABILITY.

ORIGINATED BY ANTON LIAO DATE 2018-01-31		TITLE 10/100BT MagJack® TAB UP, SHIELDED	PART NO. / DRAWING NO. SI-50170-F		STANDARD DIM. [] METRIC DIM. TOL. IN INCH AS REF.		REV. : B	PAGE : 5
DRAWN BY LIU DONGJUN DATE 2018-01-31			FILE NAME SI-50170-F_B.DWG		.X	UNIT : INCH [mm]		
					.XX	SCALE : N/A		
				.XXX	±0.005	SIZE : A4		