

## Precision Quad SPDT Analog Switch

### DESCRIPTION

The DG333A, DG333AL consist of four independently controlled single-pole double-throw analog switches. These monolithic switch is designed to control analog signals with a high degree of accuracy. The DG333A, DG333AL minimize measurement errors by offering low on-resistance (25 Ω typ.), low leakage (20 pA typ.) and low charge injection performance. The DG333AL features micro-power operation (< 1 μW typ.). This is ideal for battery operated systems. Pin 15 is not connected on the DG333A.

An improved charge injection compensation design minimizes switching transients. These switches can handle up to ± 22 V signals and have an improved continuous current of 30 mA.

The DG333A, DG333AL is fabricated in Vishay Siliconix's proprietary HVSG-2 CMOS process, resulting in higher speed and lower power consumption. An epitaxial layer prevents latchup. Each switch conducts equally well in both directions when on. When off, they block voltages up to the power-supply levels.

### BENEFITS

- Rail-to-rail analog signal range
- Simple logic interface
- High precision and accuracy
- Minimal transients
- Low distortion
- Reduced power consumption
- Improved reliability
- Break-before-make switching action

### DUAL-IN-LINE, WIDE-BODY SOIC AND TSSOP

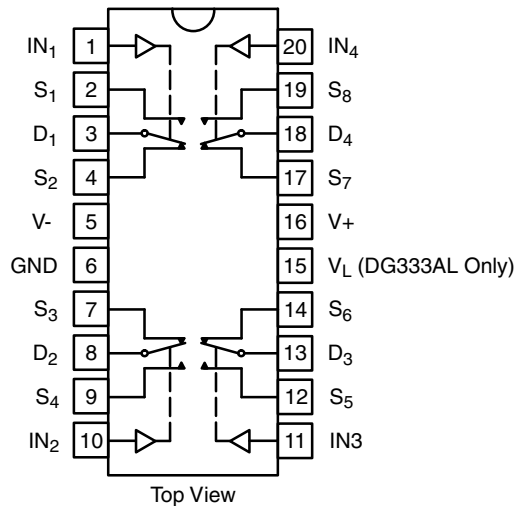

### FEATURES

- ± 22 V supply voltage range
- TTL and CMOS compatible logic
- Low on-resistance (25 Ω)
- On-resistance matched between channels (< 2 Ω)
- Flat on-resistance over analog signal range ( $\Delta < 3 \Omega$ )
- Low charge injection (1 pC)
- Low leakage (0.2 nA)
- Fast switching (175 ns)
- Single-supply operation (5 V to 40 V)
- ESD tolerance > 2 kV per 3015.x
- Low power (< 1 μA) - DG333A, DG333AL

### APPLICATIONS

- Audio switching
- Test equipment
- Portable instrumentation
- Communication systems
- PBX, PABX
- Computer peripherals
- Mass storage systems
- Switched-capacitor networks
- Battery-powered systems

### TRUTH TABLE

LOGIC	SW1, 4, 5, 8 NORMALLY OPEN	SW2, 3, 6, 7 NORMALLY CLOSED
0	Off	On
1	On	Off

### Note

- Logic "0" ≤ 0.8 V  
Logic "1" ≥ 2.4 V

ORDERING INFORMATION		
TEMP. RANGE	PACKAGE	PART NUMBER <sup>a</sup>
-40 °C to +85 °C	20-pin plastic DIP	DG333ADJ-E3
		DG333ALDJ-E3
	20-pin wide-body SOIC (shipped in tubes)	DG333ADW-E3
		DG333ALDW-E3
	20-pin wide-body SOIC (shipped in tape and reel)	DG333ADW-T1-E3
		DG333ALDW-T1-E3
20-Pin TSSOP (shipped in tape and reel)	DG333ADQ-T1-E3	
		DG333ALDQ-T1-E3

**Note**

a. For standard tin / lead external termination, remove the "-E3" from the ordering part number

ABSOLUTE MAXIMUM RATINGS			
PARAMETER		LIMIT	UNIT
Voltages referenced V <sub>+</sub> to V <sub>-</sub>		44	V
GND		30	
V <sub>+</sub> to GND		40	
Digital inputs <sup>a</sup> V <sub>S</sub> , V <sub>D</sub>		(V <sub>-</sub> ) - 2 to (V <sub>+</sub> ) + 2 or 30 mA, whichever occurs first	
Current, any terminal		30	mA
Peak current S or D (pulsed at 1 ms, 10 % duty cycle max.)		100	
Storage temperature		-65 to +125	°C
Power dissipation (package) <sup>b</sup>	20-pin plastic DIP <sup>c</sup>	890	mW
	20-pin wide SOIC <sup>d</sup>	800	

**Notes**

- Signals on S<sub>x</sub>, D<sub>x</sub>, or IN<sub>x</sub> exceeding V<sub>+</sub> or V<sub>-</sub> will be clamped by internal diodes. Limit forward diode current to maximum current ratings
- All leads welded or soldered to PC board
- Derate 12 mW/°C above 75 °C
- Derate 10 mW/°C above 75 °C

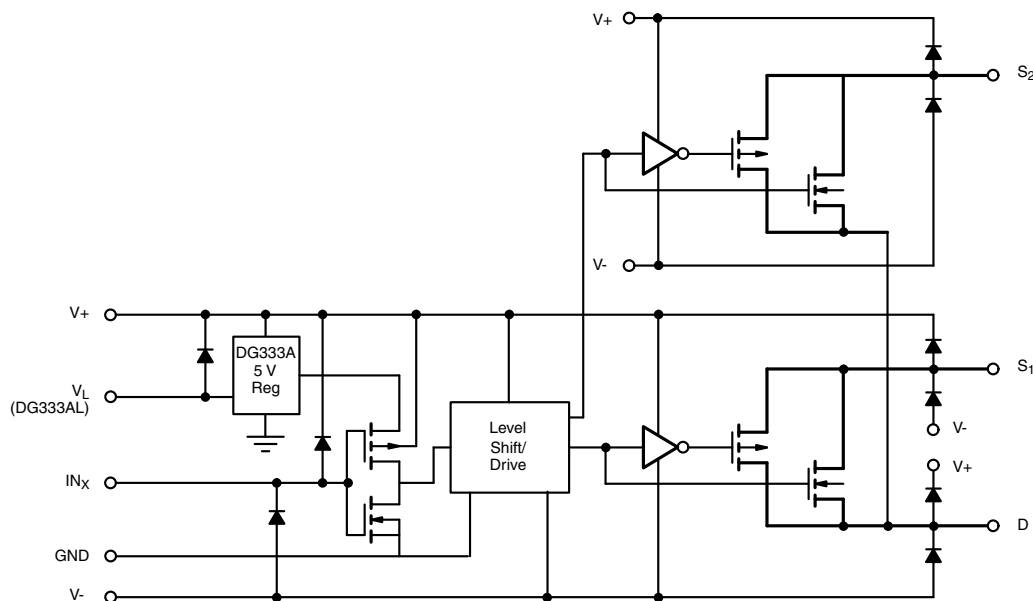
**SCHEMATIC DIAGRAM** (Typical channel)

**Fig. 1**



SPECIFICATIONS							
PARAMETER	SYMBOL	TEST CONDITIONS UNLESS OTHERWISE SPECIFIED $V_+ = 15\text{ V}$ , $V_- = -15\text{ V}$ $V_{IN} = 2.4\text{ V}$ or $0.8\text{ V}^e$	TEMP. <sup>a</sup>	LIMITS D SUFFIX -40 °C to +85 °C			UNIT
				MIN. <sup>b</sup>	TYP. <sup>c</sup>	MAX. <sup>b</sup>	
<b>Analog Switch</b>							
Analog signal range <sup>d</sup>	$V_{ANALOG}$		Full	V-	-	V+	V
Channel on-resistance	$R_{DS(on)}$	$I_S = -10\text{ mA}$ , $V_D = \pm 10\text{ V}$	Room	-	25	45	$\Omega$
On-resistance flatness			Full	-	-	90	
R <sub>DS(on)</sub> match between channels <sup>f</sup>	$\Delta R_{DS(on)}$	$I_S = -10\text{ mA}$ , $V_D = \pm 5\text{ V}$ $V_+ = 16.5\text{ V}$ , $V_- = -16.5\text{ V}$	Room	-	-	3	
			Full	-	-	5	
R <sub>DS(on)</sub> match between channels <sup>f</sup>	$\Delta R_{DS(on)}$	$I_S = -10\text{ mA}$ , $V_D = \pm 10\text{ V}$	Room	-	-	2	
			Full	-	-	4	
Source off leakage current	$I_{S(off)}$	$V_D = 15.5\text{ V}$ , $V_S = 15.5\text{ V}$ $V_+ = 16.5\text{ V}$ , $V_- = -16.5\text{ V}$	Room	-0.25	-	0.25	nA
			Hot	-20	-	20	
Channel on leakage current	$I_{D(on)}$	$V_D = \pm 15.5\text{ V}$ , $V_{S(open)} = \pm 15.5\text{ V}$ $V_+ = 16.5\text{ V}$ , $V_- = -16.5\text{ V}$	Room	-0.75	-	0.75	nA
			Hot	-60	-	60	
<b>Digital Control</b>							
Input voltage high	$V_{INH}$		Full	2.4	-	-	V
Input voltage low	$V_{INL}$		Full	-	-	0.8	
Input current	$I_{INL}$ or $I_{INH}$	$V_{INH}$ or $V_{INL}$	Full	-1	-	1	$\mu\text{A}$
<b>Dynamic Characteristics</b>							
Turn-on time	$t_{ON}$	See switching time test circuit see figure 2	Room	-	-	175	ns
Turn-off time	$t_{OFF}$		Room	-	-	145	
Break-before-make time delay	$t_D$	See figure 3	Room	5	-	-	
Charge injection <sup>d</sup>	Q	$C_L = 10\text{ nF}$ , $V_{gen} = 0\text{ V}$ , $R_{gen} = 0\ \Omega$	Room	-	-	10	pC
Off-isolation	OIRR	$R_L = 75\ \Omega$ , $C_L = 5\text{ pF}$ , $V_D = 2.3\text{ V}_{RMS}$ , $f = 1\text{ MHz}$	Room	-	72	-	dB
Channel-to-channel crosstalk	$X_{TALK}$		Room	-	80	-	
Off capacitance	$C_{OFF}$	$f = 1\text{ MHz}$ , $V_S = 0\text{ V}$	Room	-	8	-	pF
Channel on capacitance	$C_{ON}$		Room	-	12	-	
<b>Power Supplies</b>							
Positive supply current	$I_+$	DG333A: $V_{IN} = 0\text{ V}$ or $5\text{ V}$	Room	-	-	200	$\mu\text{A}$
Negative supply current	$I_-$		Room	-1	-	-	
Positive supply current	$I_+$	DG333AL: $V_{IN} = 0\text{ V}$ or $5\text{ V}$ , $V_L = 5\text{ V}$	Room	-	-	1	
Logic supply current	$I_L$		Room	-	-	1	
Negative supply current	$I_-$		Room	-1	-	-	
Supply voltage range	V+/V-		Full	$\pm 4$	-	$\pm 22$	



SPECIFICATIONS (Unipolar Supplies)							
PARAMETER	SYMBOL	TEST CONDITIONS UNLESS OTHERWISE SPECIFIED V+ = 12 V, V- = 0 V T <sub>A</sub> = 25°C	TEMP. <sup>a</sup>	LIMITS D SUFFIX -40 °C to +85°C			UNIT
				MIN. <sup>b</sup>	TYP. <sup>c</sup>	MAX. <sup>b</sup>	
<b>Analog Switch</b>							
Analog signal range <sup>d</sup>	V <sub>ANALOG</sub>		Full	V-	-	V+	V
Channel on-resistance	R <sub>DS(on)</sub>	I <sub>S</sub> = -10 mA, V <sub>D</sub> = 10, 1 V	Room	-	35	75	Ω
Source off leakage current	I <sub>S(off)</sub>	V <sub>D</sub> = 11 V, V <sub>S(open)</sub> = 1 V	Room	-	-	0.25	nA
Channel on leakage current	I <sub>D(on)</sub>	V <sub>D</sub> = 11 V, V <sub>S(open)</sub> = 0 V V <sub>D</sub> = 1 V, V <sub>S(open)</sub> = V+	Room	-	-	0.75	
<b>Dynamic Characteristics</b>							
Turn-on time	t <sub>on</sub>	See switching time test circuit see figure 2	Room	-	90	-	ns
Turn-off time	t <sub>off</sub>		Room	-	45	-	
Break-before-make time delay	t <sub>D</sub>	See figure 3	Room	5	10	-	
<b>Power Supplies</b>							
Positive supply current	I <sub>+</sub>	DG333A: V <sub>IN</sub> = 0 V or 5 V	Room	-	-	200	μA
			Room	-	-	1	
Positive supply current	I <sub>+</sub>	DG333AL: V <sub>IN</sub> = 0 V or 5 V, V <sub>L</sub> = 5 V	Room	-	-	1	
Logic supply current	I <sub>L</sub>		Room	-	-	1	
Positive supply range	V+		Room	5	-	40	V

**Notes**

- a. Room = 25 °C, Full = as determined by the operating temperature suffix
- b. The algebraic convention whereby the most negative value is a minimum and the most positive a maximum, is used in this datasheet
- c. Typical values are for DESIGN AID ONLY, not guaranteed nor subject to production testing
- d. Guaranteed by design, not subject to production test
- e. V<sub>IN</sub> = input voltage to perform proper function
- f. On-resistance match and flatness are guaranteed only for bipolar supply operation

Stresses beyond those listed under "Absolute Maximum Ratings" may cause permanent damage to the device. These are stress ratings only, and functional operation of the device at these or any other conditions beyond those indicated in the operational sections of the specifications is not implied. Exposure to absolute maximum rating conditions for extended periods may affect device reliability.

**TYPICAL CHARACTERISTICS** (T<sub>A</sub> = 25 °C, unless otherwise noted)

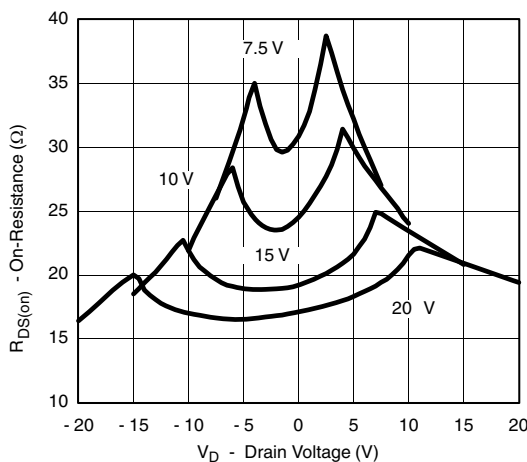

R<sub>DS(on)</sub> vs. V<sub>D</sub> (Dual Supply)

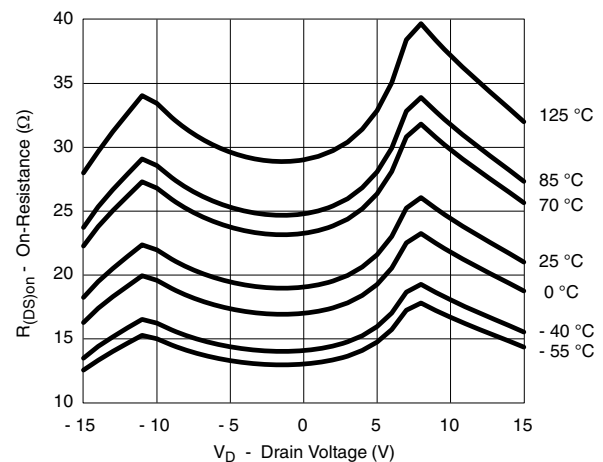

R<sub>DS(on)</sub> vs. V<sub>D</sub> and Temperature (Dual Supply)



TYPICAL CHARACTERISTICS (T<sub>A</sub> = 25 °C, unless otherwise noted)

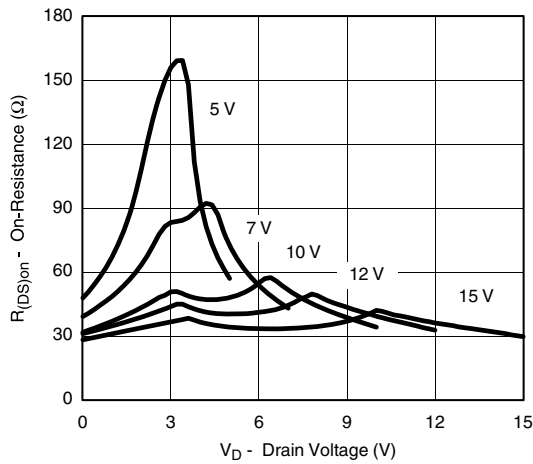

**R<sub>DS(on)</sub> vs. V<sub>D</sub> (Single Supply)**

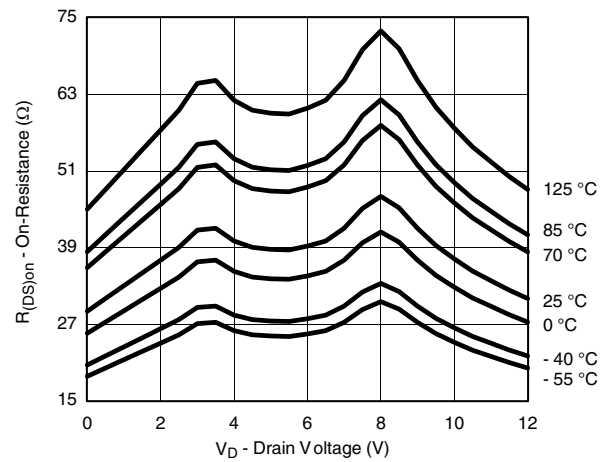

**R<sub>DS(on)</sub> vs. V<sub>D</sub> and Temperature (Single Supply)**

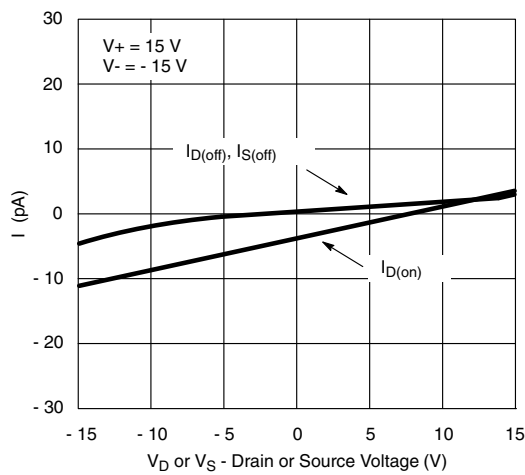

**Leakage Current vs. Analog Voltage**

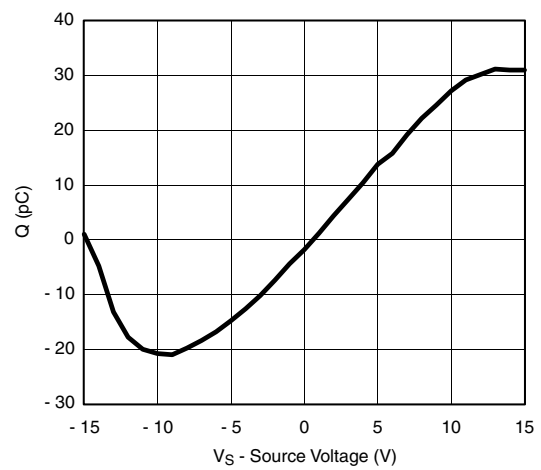

**Drain Charge Injection**

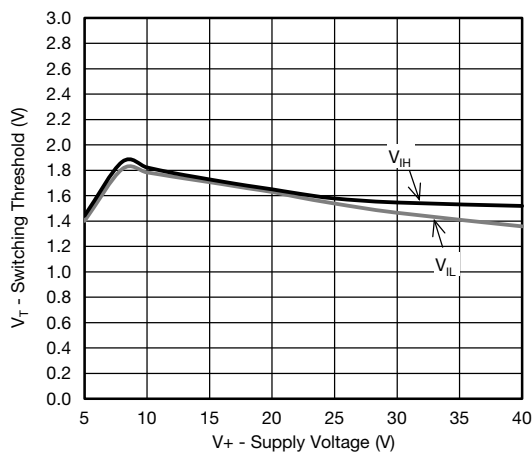

**Input Switching Threshold vs. Supply Voltage**

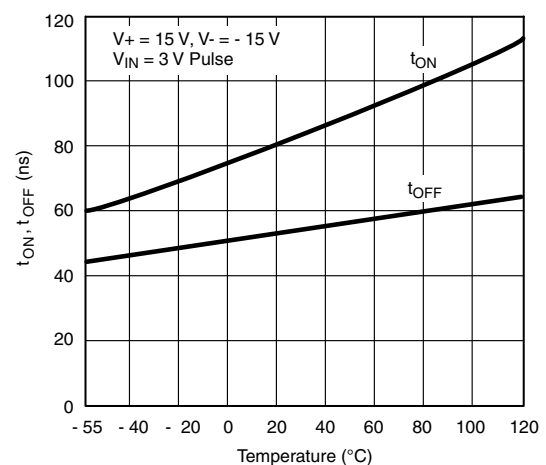

**Switching Time vs. Temperature**



TYPICAL CHARACTERISTICS (T<sub>A</sub> = 25 °C, unless otherwise noted)

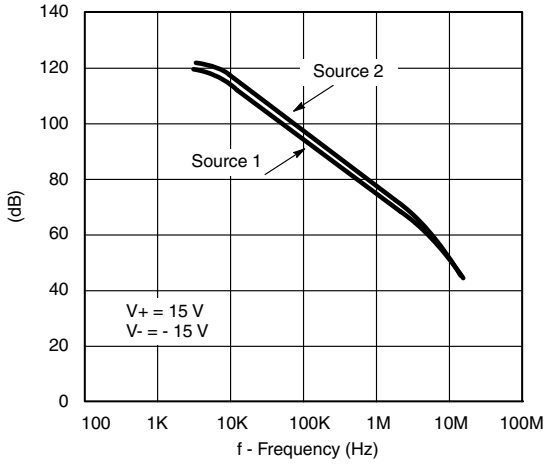

Crosstalk and Off Isolation vs. Frequency

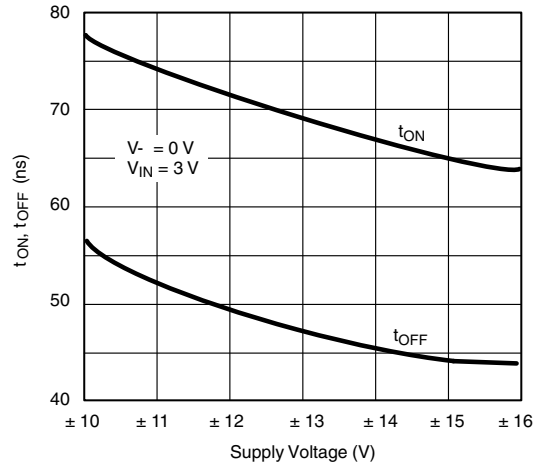

Switching Time vs. Supply Voltages

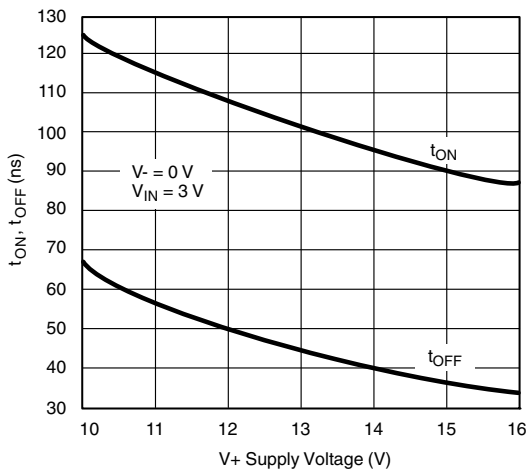

Switching Time vs. V+

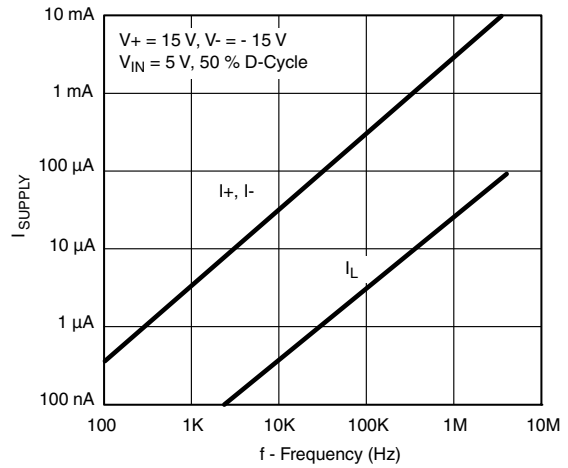

Power Supply Currents vs. Switching Frequency

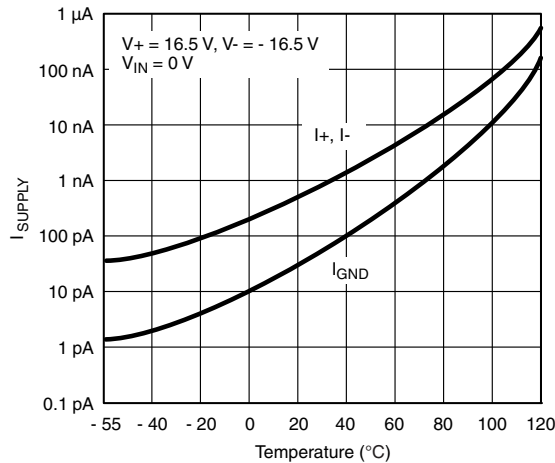

Supply Current vs. Temperature

TEST CIRCUITS

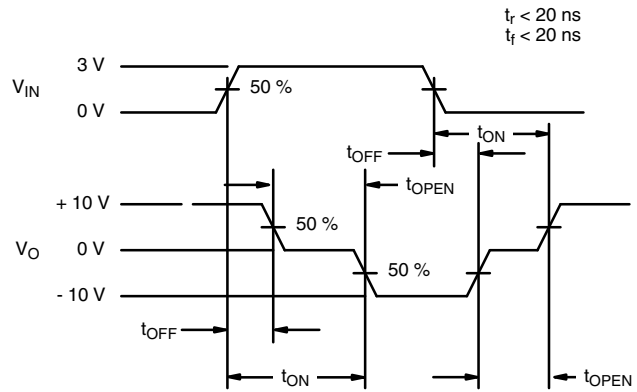
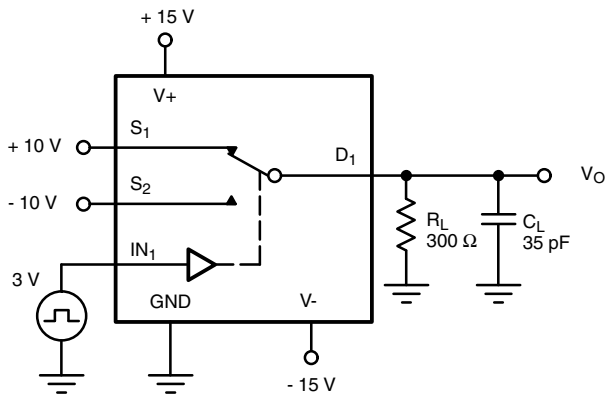

Repeat Test for IN<sub>2</sub>, IN<sub>3</sub> and IN<sub>4</sub>

Fig. 2 - Switching Time

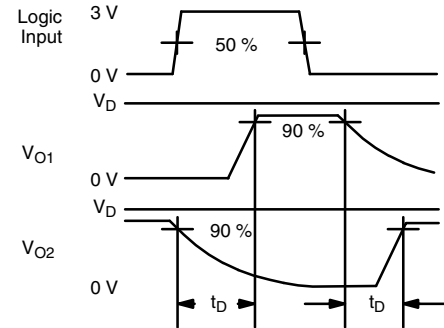
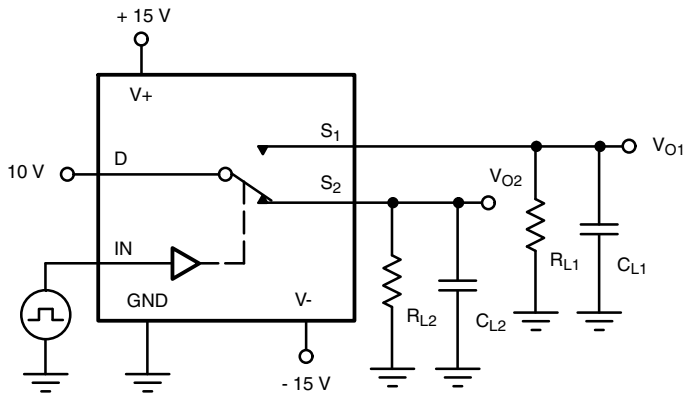

$R_L = 300 \Omega$ ,  $C_L = 35 \text{ pF}$   
 $C_L$  (includes fixture and stray capacitance)

Fig. 3 - Break-Before-Make

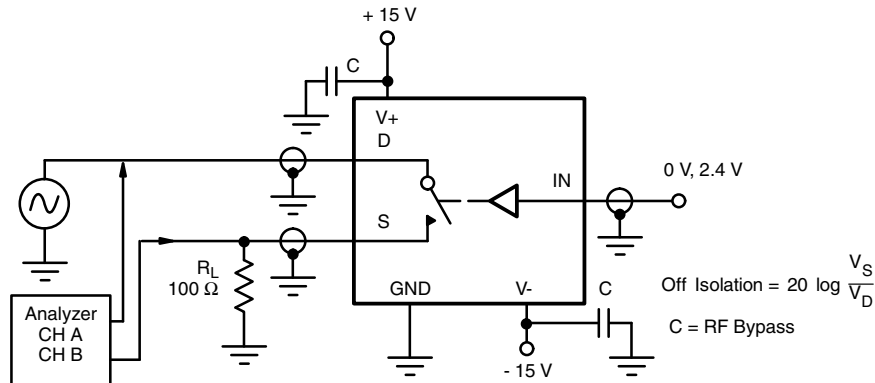

Off Isolation =  $20 \log \frac{V_S}{V_D}$   
 $C = \text{RF Bypass}$

Fig. 4 - Off Isolation

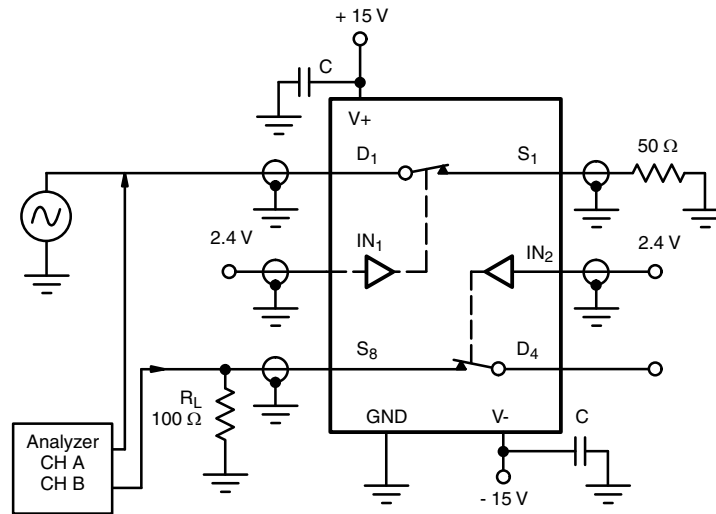
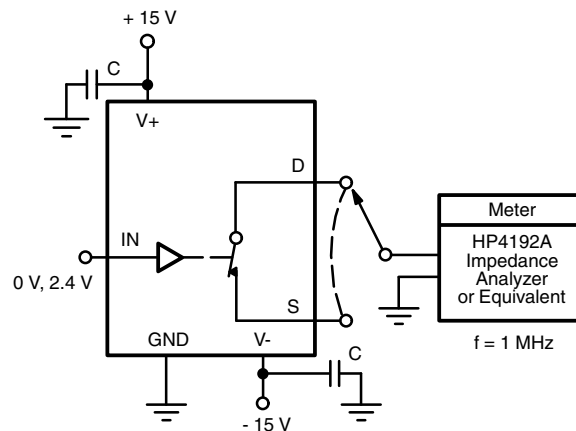
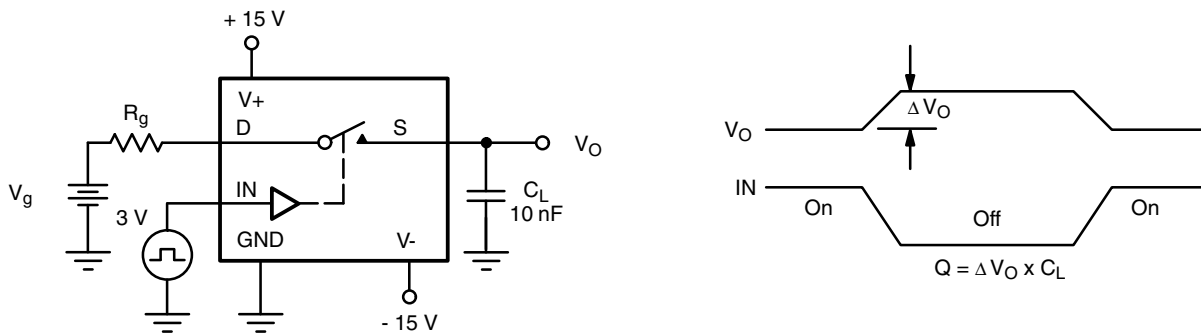
**TEST CIRCUITS**

**Fig. 5 - Crosstalk**

**Fig. 6 - Capacitances**

**Fig. 7 - Charge Injection**

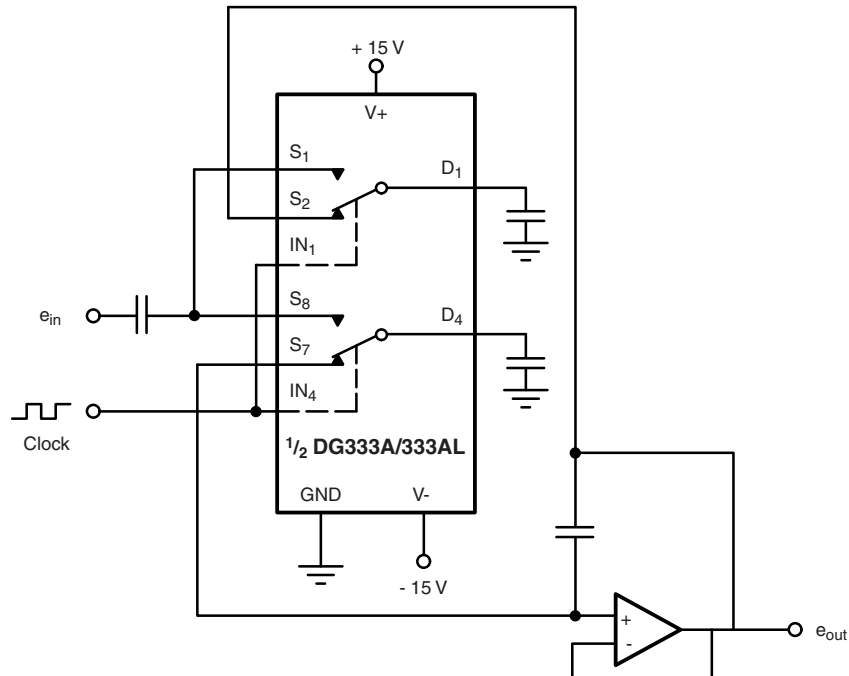
**APPLICATIONS**
**Band-Pass Switched Capacitor Filter**

Single-pole double-throw switches are a common element for switched capacitor networks and filters. The fast switching times and low leakage of the DG333A, DG333AL allow for higher clock rates and consequently higher filter operating frequencies. Figure 8 shows two capacitors being switched.

The DG333A, DG333AL is capable of switching four capacitors.



**Fig. 8 - Band-Pass Switched Capacitor Filter**



PRODUCT SUMMARY				
Part number	DG333A	DG333A	DG333AL	DG333AL
Status code	2	2	2	2
Configuration	SPDT x 4	SPDT x 4	SPDT x 4	SPDT x 4
Single supply min. (V)	5	5	5	5
Single supply max. (V)	36	36	36	36
Dual supply min. (V)	5	5	5	5
Dual supply max. (V)	22	22	22	22
On-resistance ( $\Omega$ )	25	25	25	25
Charge injection (pC)	10	10	10	10
Source on capacitance (pF)	12	12	12	12
Source off capacitance (pF)	8	8	8	8
Leakage switch on typ. (nA)	-	-	-	-
Leakage switch off max. (nA)	0.25	0.25	0.25	0.25
-3 dB bandwidth (MHz)	-	-	-	-
Package	SO-20 (wide)	TSSOP-20	SO-20 (wide)	TSSOP-20
Functional circuit / applications	Multi purpose, instrumentation, medical and healthcare	Multi purpose, instrumentation, medical and healthcare	Multi purpose, instrumentation, medical and healthcare	Multi purpose, instrumentation, medical and healthcare
Interface	Parallel	Parallel	Parallel	Parallel
Single supply operation	Yes	Yes	Yes	Yes
Dual supply operation	Yes	Yes	Yes	Yes
Turn on time max. (ns)	175	175	175	175
Crosstalk and off isolation	-72	-72	-72	-72

Vishay Siliconix maintains worldwide manufacturing capability. Products may be manufactured at one of several qualified locations. Reliability data for Silicon Technology and Package Reliability represent a composite of all qualified locations. For related documents such as package/tape drawings, part marking, and reliability data, see [www.vishay.com/ppg?70803](http://www.vishay.com/ppg?70803).



**PDIP: 20-LEAD**

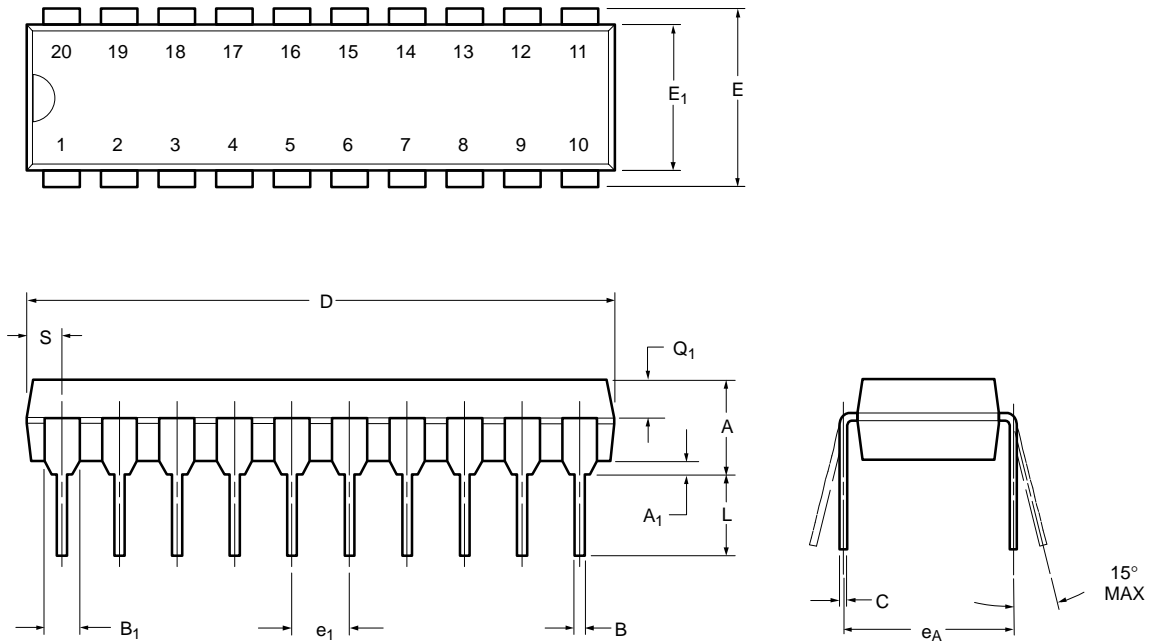

Dim	MILLIMETERS		INCHES	
	Min	Max	Min	Max
<b>A</b>	3.81	5.08	0.150	0.200
<b>A<sub>1</sub></b>	0.38	1.27	0.015	0.050
<b>B</b>	0.38	0.51	0.015	0.020
<b>B<sub>1</sub></b>	0.89	1.65	0.035	0.065
<b>C</b>	0.20	0.30	0.008	0.012
<b>D</b>	24.89	26.92	0.980	1.060
<b>E</b>	7.62	8.26	0.300	0.325
<b>E<sub>1</sub></b>	5.59	7.11	0.220	0.280
<b>e<sub>1</sub></b>	2.29	2.79	0.090	0.110
<b>e<sub>A</sub></b>	7.37	7.87	0.290	0.310
<b>L</b>	3.175	3.81	0.123	0.150
<b>Q<sub>1</sub></b>	1.27	2.03	0.050	0.080
<b>S</b>	1.02	2.03	0.040	0.080

ECN: S-03946—Rev. B, 09-Jul-01  
DWG: 5484



**SOIC (WIDE-BODY): 20-LEAD**

ECN: S-03946—Rev. C, 09-Jul-01  
DWG: 5848

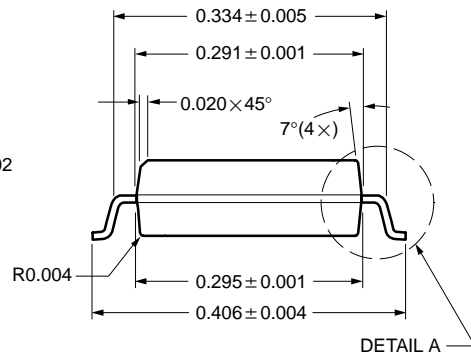
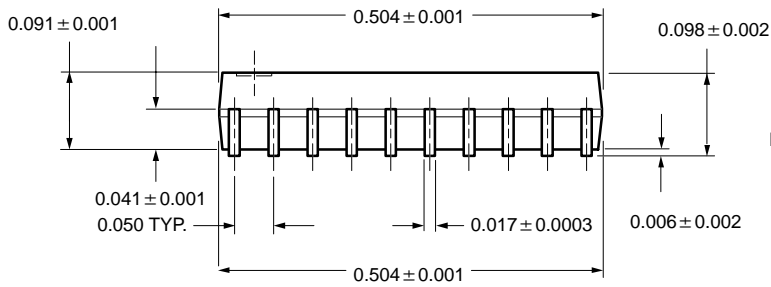
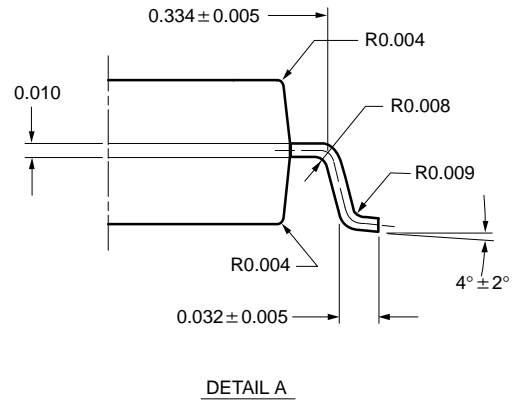
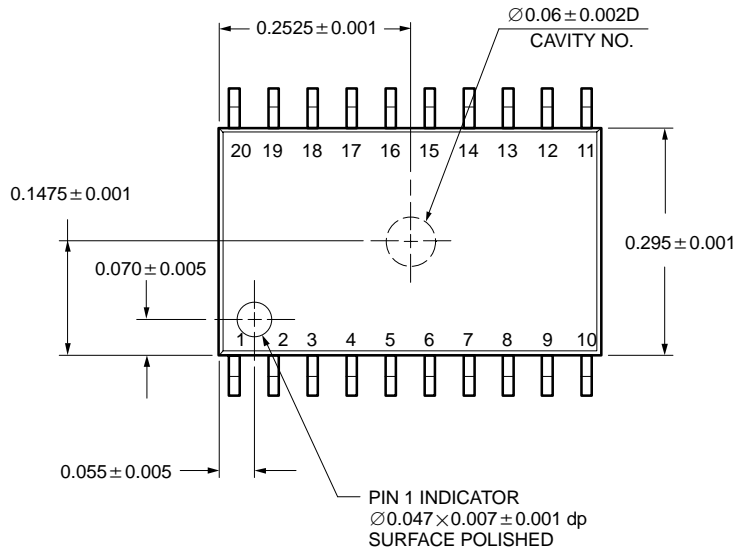

All Dimensions In Inches.

### TSSOP: 20-LEAD

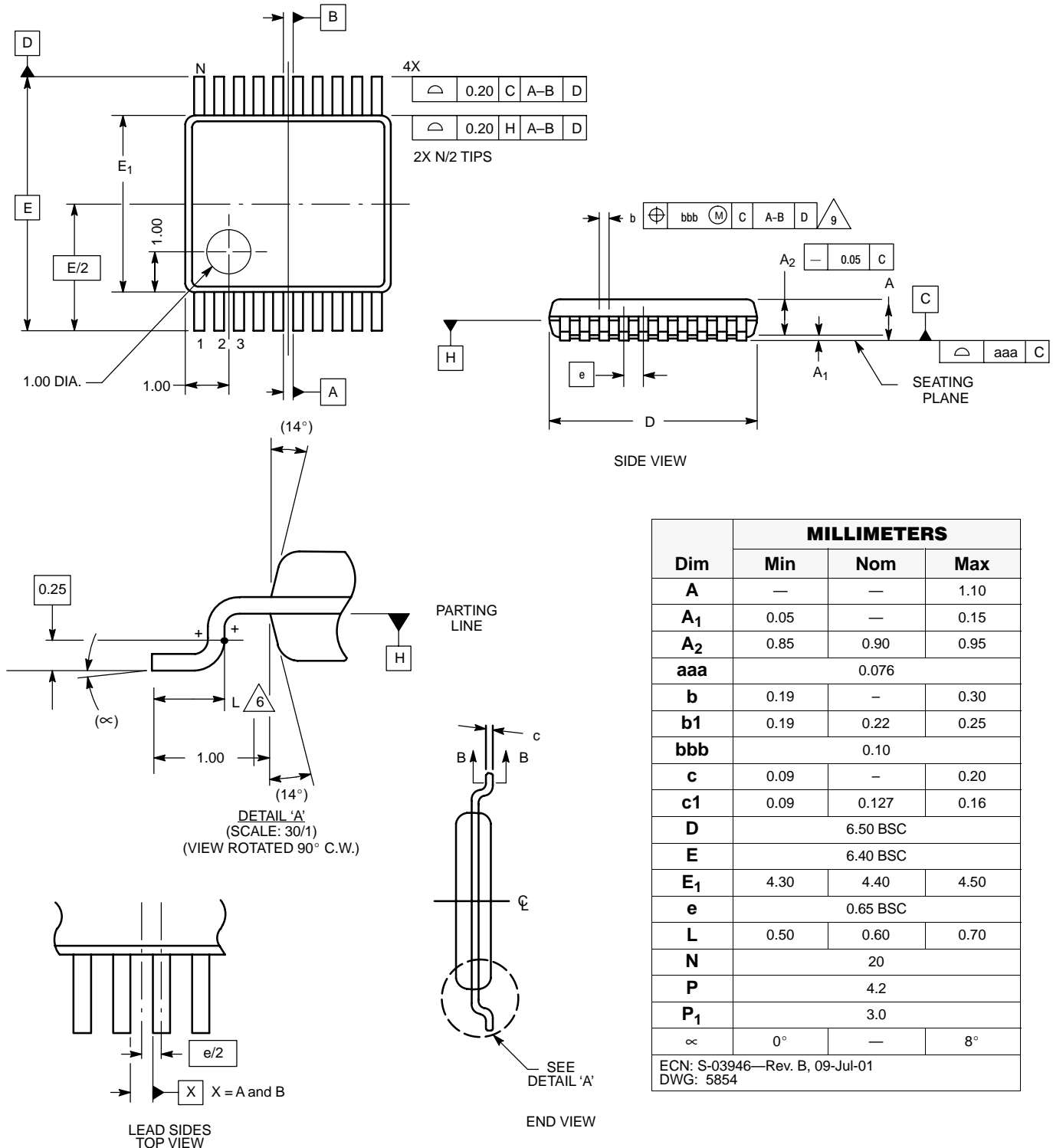

Dim	MILLIMETERS		
	Min	Nom	Max
A	—	—	1.10
A <sub>1</sub>	0.05	—	0.15
A <sub>2</sub>	0.85	0.90	0.95
aaa	0.076		
b	0.19	—	0.30
b <sub>1</sub>	0.19	0.22	0.25
bbb	0.10		
c	0.09	—	0.20
c <sub>1</sub>	0.09	0.127	0.16
D	6.50 BSC		
E	6.40 BSC		
E <sub>1</sub>	4.30	4.40	4.50
e	0.65 BSC		
L	0.50	0.60	0.70
N	20		
P	4.2		
P <sub>1</sub>	3.0		
$\infty$	0°	—	8°
ECN: S-03946—Rev. B, 09-Jul-01 DWG: 5854			



## Disclaimer

ALL PRODUCT, PRODUCT SPECIFICATIONS AND DATA ARE SUBJECT TO CHANGE WITHOUT NOTICE TO IMPROVE RELIABILITY, FUNCTION OR DESIGN OR OTHERWISE.

Vishay Intertechnology, Inc., its affiliates, agents, and employees, and all persons acting on its or their behalf (collectively, "Vishay"), disclaim any and all liability for any errors, inaccuracies or incompleteness contained in any datasheet or in any other disclosure relating to any product.

Vishay makes no warranty, representation or guarantee regarding the suitability of the products for any particular purpose or the continuing production of any product. To the maximum extent permitted by applicable law, Vishay disclaims (i) any and all liability arising out of the application or use of any product, (ii) any and all liability, including without limitation special, consequential or incidental damages, and (iii) any and all implied warranties, including warranties of fitness for particular purpose, non-infringement and merchantability.

Statements regarding the suitability of products for certain types of applications are based on Vishay's knowledge of typical requirements that are often placed on Vishay products in generic applications. Such statements are not binding statements about the suitability of products for a particular application. It is the customer's responsibility to validate that a particular product with the properties described in the product specification is suitable for use in a particular application. Parameters provided in datasheets and / or specifications may vary in different applications and performance may vary over time. All operating parameters, including typical parameters, must be validated for each customer application by the customer's technical experts. Product specifications do not expand or otherwise modify Vishay's terms and conditions of purchase, including but not limited to the warranty expressed therein.

Hyperlinks included in this datasheet may direct users to third-party websites. These links are provided as a convenience and for informational purposes only. Inclusion of these hyperlinks does not constitute an endorsement or an approval by Vishay of any of the products, services or opinions of the corporation, organization or individual associated with the third-party website. Vishay disclaims any and all liability and bears no responsibility for the accuracy, legality or content of the third-party website or for that of subsequent links.

Vishay products are not designed for use in life-saving or life-sustaining applications or any application in which the failure of the Vishay product could result in personal injury or death unless specifically qualified in writing by Vishay. Customers using or selling Vishay products not expressly indicated for use in such applications do so at their own risk. Please contact authorized Vishay personnel to obtain written terms and conditions regarding products designed for such applications.

No license, express or implied, by estoppel or otherwise, to any intellectual property rights is granted by this document or by any conduct of Vishay. Product names and markings noted herein may be trademarks of their respective owners.