

MTS-360

Miniature Hall-Effect Through-Shaft Rotary Position Sensor

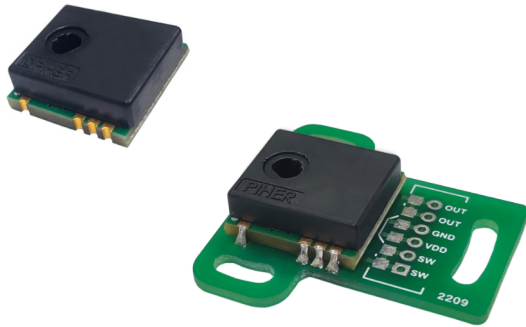

KEY FEATURES



True, contactless operation

Without any gears or mechanical interfaces the sensor is easily assembled and calibrated and subject to limited wear and tear over lifetime.

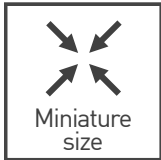

Fits in the smallest of spaces

With a footprint of less than 18 x 18mm, height of 5.9mm and less than 3g this rotary sensor can be used in even the most space-constraint application.



Through-hole design

Allows shaft insertion from top or bottom, simple assembly and makes it even more suitable in applications where space is limited.

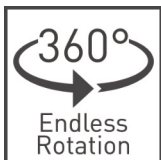

360 degree absolute position feedback

Endless mechanical rotational angle without dead band, keeps the position on power loss with programmable electrical angles from 15 to 360 degrees.



Durable and robust design

The non-contacting design allows for an extra-long product lifetime of up to 50 million cycles.



Adaptable to your requirements

Programmable transfer function and switch outputs as well as different output protocols and redundancy levels available.

DESCRIPTION

The MTS-360 provides a true breakthrough in contactless sensor technology by combining a through-shaft design with 360° absolute position feedback in an ultra miniature size. The result is the smallest fully featured rotary sensor on the market with reliability up to 50 million cycles.

With its tiny size, engineers can now integrate a fully featured rotary sensor directly on their PCB without the packaging issues that typically accompany encoders or other absolute position devices. The exceptionally low profile fits easily in places that were previously too small for pre-packaged rotary sensors.

The MTS-360 PCB package enables time and cost-savings by easily mounting a fully featured rotary sensor including connector without the need to design a printed circuit board for the sensor.

APPLICATIONS

Industrial

- ▶Optical image stabilization
- ▶Precision biomedical devices
- ▶Instrumentation
- ▶Autonomous warehouse robotics
- ▶Robotics and automation feedback

Home and Building Automation

- ▶HVAC systems

Transportation

- ▶Valve monitoring
- ▶Conveyor operation

HVOR

- ▶Autonomous steering
- ▶Joystick controls
- ▶Hand throttle position

MTS-360

Miniature Hall-Effect Through-Shaft Rotary Position Sensor

MECHANICAL SPECIFICATIONS

Rotational life	Up to 50.000.000 cycles
Mechanical range	360° [endless rotation]

ELECTRICAL SPECIFICATIONS

Linearity ^{1,2}	±1% absolute (±0.5% upon request)
Electrical angular range ¹	Programmable from 15° to 360°
Output protocols	Analog (Ratiometric), PWM Serial Protocol (SPI)
Output	Simple Redundant Full-redundant (on request)
Switch output	Yes, programmable
Switch accuracy ¹	±3°
Resolution	Analog, PWM SPI Up to 12 bit Up to 14 bit
Supply voltage ¹	5V ±10%
Supply current	Single version Redundant version Typ 8.5 mA Typ 17 mA
Voltage protection	+20V / -10V
Self-diagnostic features	yes

¹ Other specifications available

² Ferromagnetic materials close to the sensor (i.e. mounting surface) may affect the sensor's linearity.

ENVIRONMENTAL SPECIFICATIONS

Model	MTS-360	MTS-360PCB
Operating and storage temperature ¹	-40° to +125°C	with connector: -40° to +105°C without connector: -40° to +125°C
Shock	50g	
Vibration	5-2000 Hz; 20g; Amax 0,75 mm	
Sealing ¹	IP50	

¹ Other specifications available



Sensitive to Electro Static Discharge (ESD).
Observe control procedures whenever
handling semiconductor products.

RECOMMENDED REFLOW PROFILE

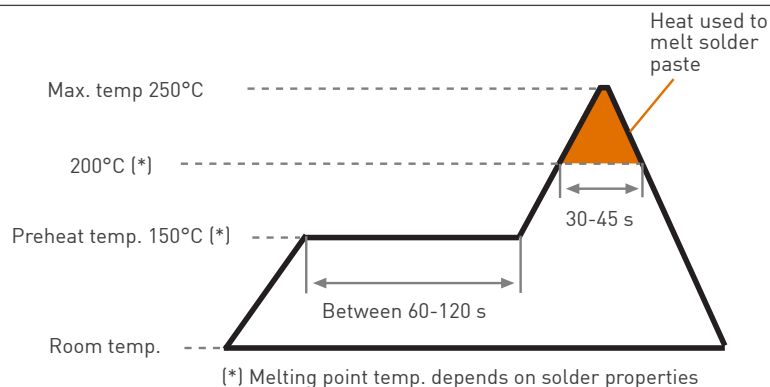

The recommended reflow profile is provided as a guideline. Optimal profile may differ due to oven type, assembly layout or other design or process variables. Customers should verify actual device performance in their specific application and reflow process. Please contact Piher if you require additional support.

MTS-360

Miniature Hall-Effect Through-Shaft Rotary Position Sensor

DIMENSIONS MTS-360

Outer Dimensions

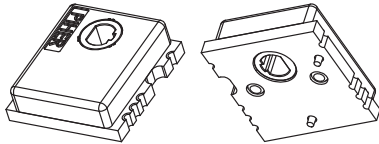

Download the STEP file here:
www.piher.net

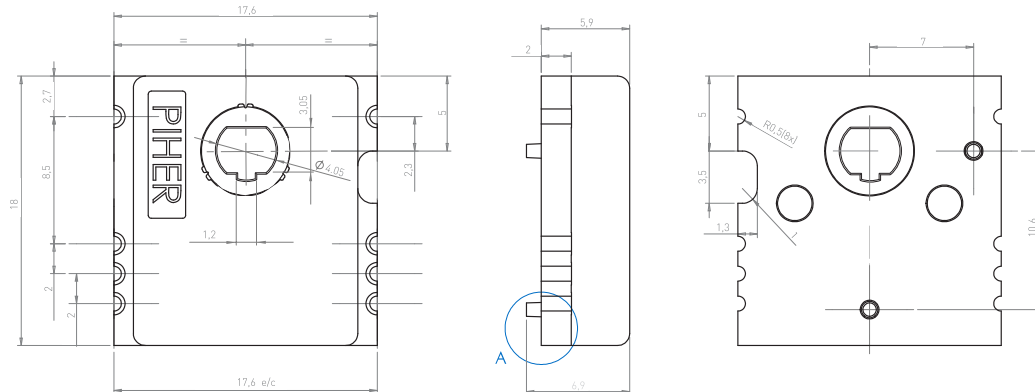

Rotor is shown at zero position. Sensor is delivered at random position

Recommended shaft dimensions

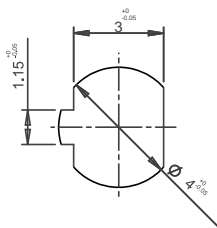

Shaft should be ferromagnetic material. If you want to use a non-ferromagnetic shaft please contact Piher.

Recommended footprint

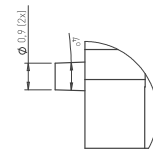
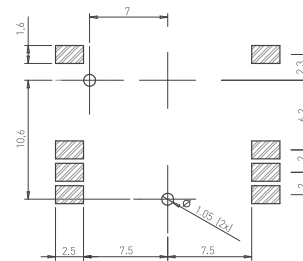

Detail A
 Scale 8:1

CONNECTION SCHEME

PIN	Simple Output	Redundant Output	SPI Output
1	Supply voltage	Switch output 2*	Power Supply
2		Signal output 2**	Power Supply
3	Switch output*	Ground	//SS
4		Ground	SCLK
5	Signal output**	Power supply	MOSI
6		Power supply	MOSI
7	Ground	Signal output 1**	Ground
8		Switch output 1*	Ground

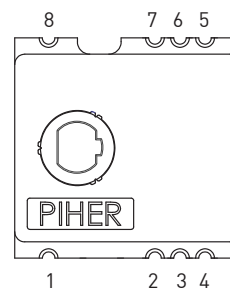

* If the feature is not used in the application, please connect to ground.

** Piher can supply the recommended wiring diagram.

More instructions of use on www.piher.net

MTS-360PCB

Miniature Hall-Effect Through-Shaft Rotary Position Sensor

DIMENSIONS MTS-360PCB

3-pin version

With connector

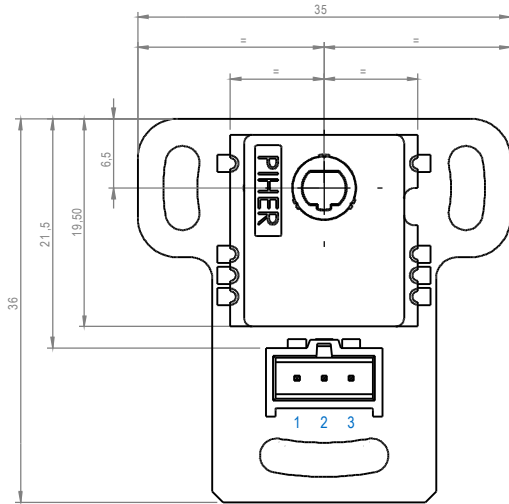

Without connector

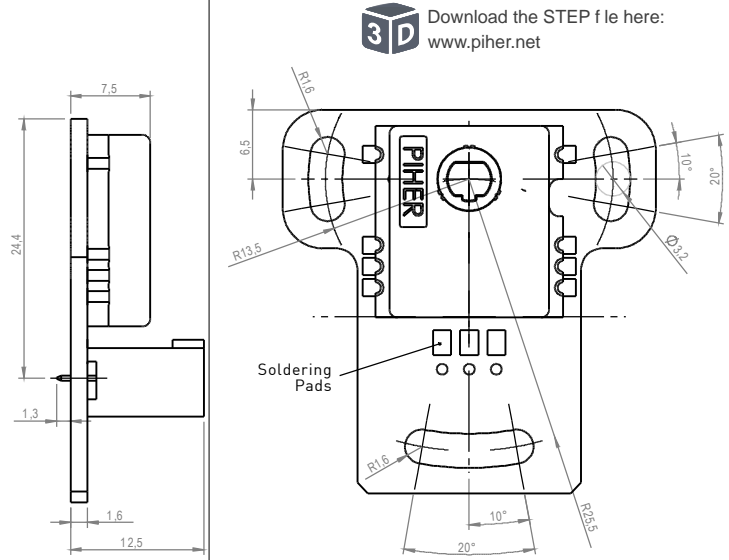

6-pin version

With connector

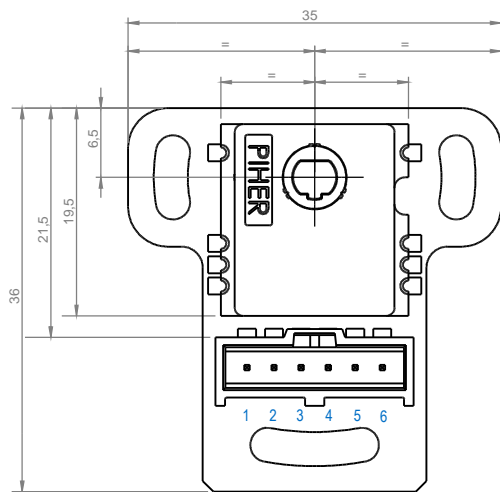

Without connector

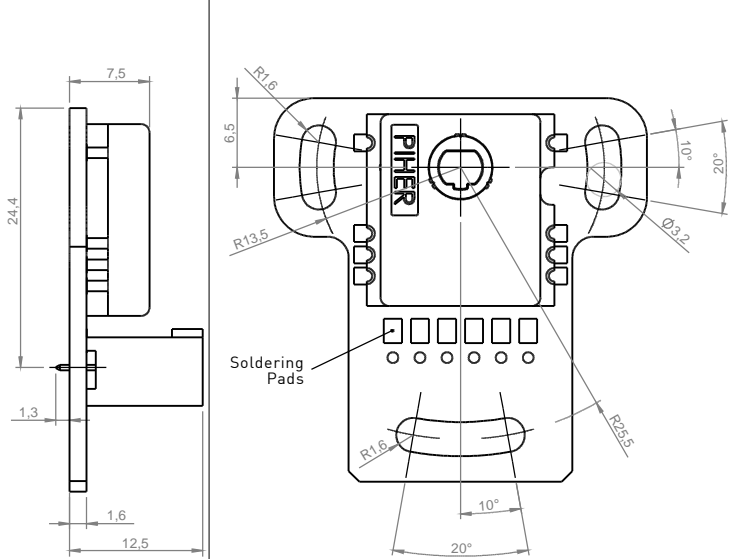

CONNECTIONS

PIN	3-pin	6-pin (simple)	6-pin (redundant)	6-pin (SPI)	Connectors	Terminals
1	Supply voltage	Switch	Ground	SCLK	Header connector: 3-pin: Molex 90136-1203 6-pin: Molex 90136-1206	Recommended crimp terminals: Molex 90119-2120 Molex 90119-2121 Molex 90119-2122
2	Signal output	Switch	Signal output 2	//SS		
3	Ground	Supply voltage	Switch 2	Supply voltage		
4	n/a	Ground	Switch 1	Ground	Recommended mate connector: 3-pin: Molex 90156-0143 6-pin: Molex 90156-0146	
5	n/a	Signal Output	Signal output 1	MOSI		
6	n/a	Signal Output	Supply voltage	MOSI		

MTS-360

Miniature Hall-Effect Through-Shaft Rotary Position Sensor

HOW TO ORDER (Example: MTS360G2-1A-C0000-ERA360-05K)

Simple Output - Analog and PWM

MTS360G2 - 1 - - - - C - ERA - 05 K - - - -

Series	Type 1 = simple	Output¹ A = analogic P = PWM	Switch² [empty] = none W = switch	Switch position² [empty] 000 016 ... 360	Output function³ C0000 C0001	Electric rotational angle⁴ ERA040 ERA041 ... ERA360	Voltage supply 05 = 5V ±10%	Temperature range K = -40°C to +125°C	PWM Frequency Hz⁵ [empty] = 200Hz F100 = 100Hz F101 = 101Hz ... F999 = 999Hz	Packaging [empty] = bulk R = reel
---------------	---------------------------	--	---	---	--	---	---------------------------------------	---	---	--

Redundant Output - Analog and PWM

MTS360G2 - 2 - - - - C - ERA - 05 K - - - -

Series	Type 2 = redundant	Switch1² [empty] = none W = switch	Switch2² [empty] = none W = switch	Output function³ C0002 C0003	Electric rotational angle⁴ ERA040 ERA041 ... ERA360	Voltage supply 05 = 5V ±10%	PWM Frequency Hz. (1)⁵ [empty] F100 F101 ... F999	PWM Frequency Hz. (2)⁵ [empty] F100 F101 ... F999	Packaging [empty] = bulk R = reel
	Output¹ AA = analogic PP = PWM	Switch1 position² [empty] 000 016 ... 360	Switch2 position² [empty] 000 016 ... 360			Temperature range K = -40°C to +125°C			

Simple Output - SPI

MTS360G2 - 1 S - C - ERA - 05 K - - - -

Series	Type 1 = simple	Output S = SPI	Output function³ C0000 C0001	Electric rotational angle⁴ ERA040 ERA041 ... ERA360	Voltage supply 05 = 5V ±10%	Temperature range K = -40°C to +125°C	Packaging [empty] = bulk R = reel
---------------	---------------------------	--------------------------	--	---	---------------------------------------	---	--

1 The analog output is ratiometric, proportional to input supply voltage.
 2 Leave empty if not applicable. Switch function diagram: see next page.
 3 Other output functions available, please check availability. Enter CXXXX as long as the new output function is not defined.
 4 Models with ERA < 40° available on request
 5 Leave empty if not applicable. Default frequency is 200 Hz

check inventory

EXAMPLE OUTPUT FUNCTIONS

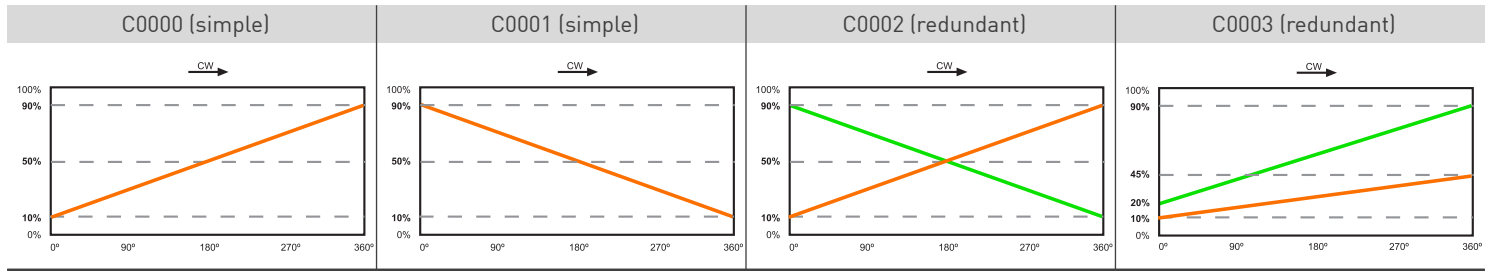

MTS-360PCB

Miniature Hall-Effect Through-Shaft Rotary Position Sensor

HOW TO ORDER (Example: MTS360G2PCB3-1A-C0000-ERA360-05K- - - - -)

Simple Output - Analogic and PWM - 3 pin version

MTS360G2PCB3	-	1	-	-	-	C	-	ERA	-	05	-	K	-	-	-
Series	Type	Output¹	Output function³	Electric rotational angle⁴	Voltage supply	Temperature range⁵	PWM Frequency Hz⁶	Connector							
	1 = simple	A = analogic P = PWM	C0000 C0001	ERA040 ERA041 ... ERA360	05 = 5V ±10%	K = -40°C to +125°C	[empty] = 200Hz F100 = 100Hz F101 = 101Hz ... F999 = 999Hz	C = with N = without							

Simple Output with Switch - Analogic and PWM - 6 pin version

MTS360G2PCB6	-	1	-	-	-	C	-	ERA	-	05	-	K	-	-	-
Series	Type	Output¹	Switch²	Switch position²	Output function³	Electric rotational angle⁴	Voltage supply	Temperature range⁵	PWM Frequency Hz⁶	Connector					
	1 = simple	A = analogic P = PWM	[empty] = none W = switch	[empty] 000 016 ... 359	C0000 C0001	ERA040 ERA041 ... ERA360	05 = 5V ±10%	K = -40°C to +125°C	[empty] = 200Hz F100 = 100Hz F101 = 101Hz ... F999 = 999Hz	C = with N = without					

Simple Output - SPI - 6 pin version

MTS360G2PCB6	-	1	-	S	-	C	-	ERA	-	05	-	K	-	-	-
Series	Type	Output	Output function³	Electric rotational angle⁴	Voltage supply	Temperature range⁵	Connector								
	1 = simple	S = SPI	C0000 C0001	ERA040 ERA041 ... ERA360	05 = 5V ±10%	K = -40°C to +125°C	C = with N = without								

Redundant Output - 6 pin version

MTS360G2PCB6	-	2	-	-	-	-	-	C	-	ERA	-	05	-	K	-	-	-
Series	Type	Switch1²	Switch2²	Output function³	Electric rotational angle⁴	Voltage supply	PWM Frequency Hz. (1)⁶	PWM Frequency Hz. (2)⁶	Connector								
	2 = redundant	[empty] = none W = switch	[empty] = none W = switch	C0002 C0003	ERA040 ERA041 ... ERA360	05 = 5V ±10%	[empty] F100 F101 ... F999	[empty] F100 F101 ... F999	C = with N = without								
		Output¹	Switch1 position²	Switch2 position²				Temperature range⁵									
		AA = analogic PP = PWM	[empty] 000 016 ... 359	[empty] 000 016 ... 359				K = -40°C to +125°C									

1 The analog output is ratiometric, proportional to input supply voltage.
 2 Leave empty if not applicable. Switch function diagram: see next page.
 3 Other output functions available, please check availability. Enter CXXXX as long as the new output function is not defined.
 4 Models with ERA < 40° available on request
 5 Temperature range is limited to +105°C for connector versions.
 6 Leave empty if not applicable. Default frequency is 200 Hz

MTS-360

Miniature Hall-Effect Through-Shaft Rotary Position Sensor

OUTPUT VOLTAGE DEPENDING ON SHAFT POSITION

MTS360G2-1A-W090-C0000-ERA360-05K

MTS360G2-1A-W180-C0072-ERA180-05K

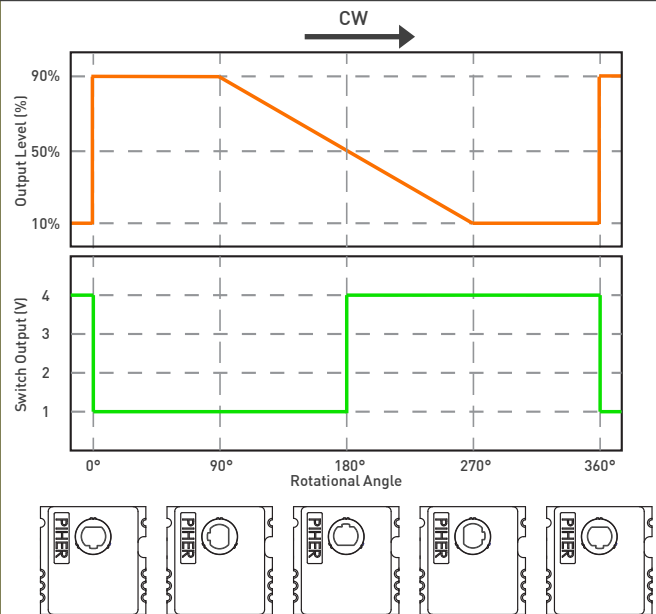
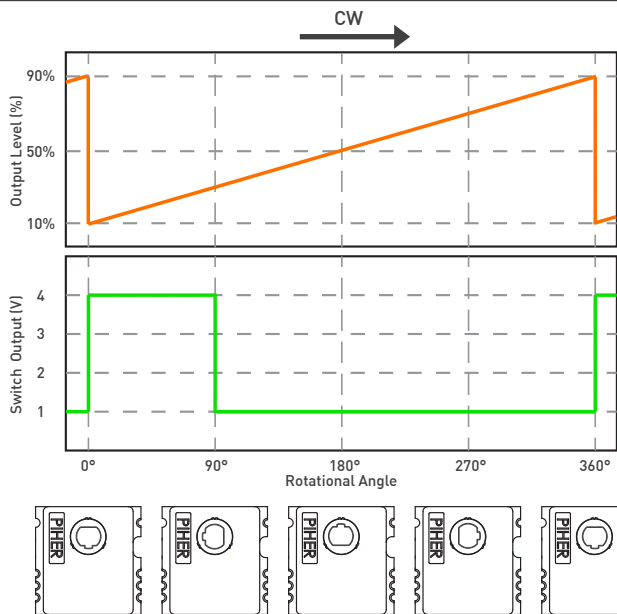

PACKAGING

Reel - Embossed Tape (max. 400 pcs / reel)

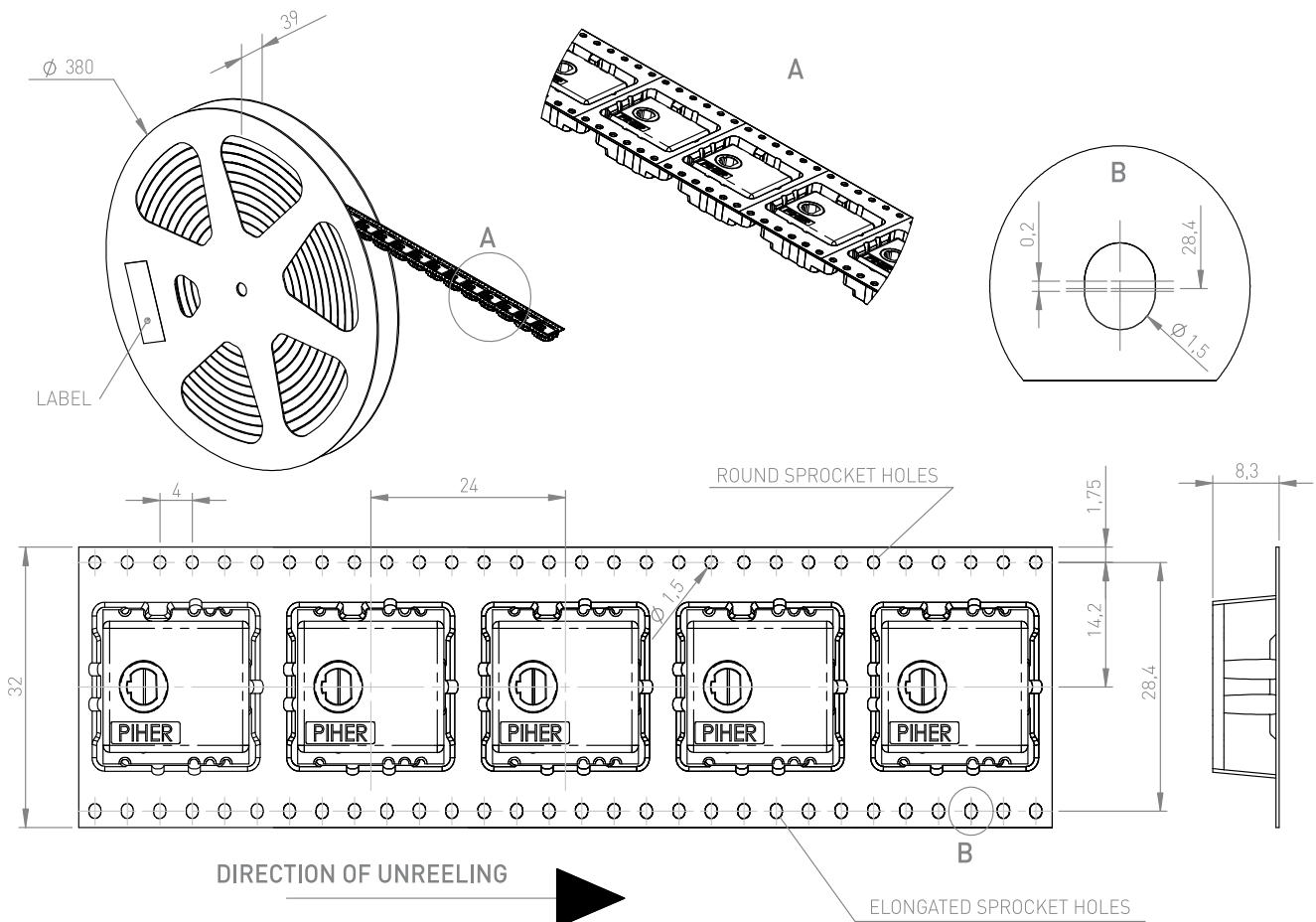

Embossed tape - reel packaging not available for MTS3605G2PCB models

MTS-360

Miniature Hall-Effect Through-Shaft Position Sensor

PACKAGING

Bulk



Box dimensions (mm): 250x160x95

OPTIONAL FEATURES AVAILABLE ON REQUEST

- ▶Special output slopes and protocols
- ▶Full redundant version with switches
- ▶Fast versions
- ▶Energy harvesting versions
- ▶IP sealing
- ▶Connectors
- ▶Shaft interfaces

OUR ADVANTAGE

- ▶Leading-edge innovative position sensing solutions
 - ▷Contactless (Hall-effect and Inductive Technology)
 - ▷Contacting (Potentiometers, Printed Electronics)
- ▶Engineering design-in support
- ▶All our products can be customized to fit target application and customer requirement
- ▶Capability to move seamlessly from development to true high-volume production
- ▶A global footprint with global engineering and commercial support
- ▶One-stop shop not limited to position sensors (temperature, pressure, gas,...) through group collaboration
- ▶Flexibility and entrepreneurship of a medium-sized company with the backing of Amphenol Corporation



Please always use the latest updated datasheets and 3D models published on our website.

Disclaimer:

The product information in this catalog is for reference purposes. Please consult for the most up to date and accurate design information. Piher Sensors & Controls S.A., its affiliates, agents, and employees, and all persons acting on its or their behalf (collectively, "Piher"), disclaim any and all liability for any errors, inaccuracies or incompleteness contained herein or in any other disclosure relating to any product described herein. Piher disclaims any and all liability arising out of the use or application of any product described herein or of any information provided herein to the maximum extent permitted by law. The product specifications do not expand or otherwise modify Piher's terms and conditions of sale, including but not limited to the warranty expressed therein, which apply to these products. No license, express or implied, by estoppel or otherwise, to any intellectual property rights is granted by this document or by any conduct of Piher. The products shown herein are not designed for use in medical, life-saving, or life-sustaining applications unless otherwise expressly indicated. Customers using or selling Piher products not expressly indicated for use in such applications do so entirely at their own risk and agree to fully indemnify Piher for any damages arising or resulting from such use or sale. Please contact authorized Piher personnel to obtain written terms and conditions regarding products designed for such applications. Product names and markings noted herein may be trademarks of their respective owners. Information contained in and/or attached to this catalogue may be subject to export control regulations of the European Community, USA, or other countries. Each recipient of this document is responsible to ensure that usage and/or transfer of any information contained in this document complies with all relevant export control regulations. If you are in any doubt about the export control restrictions that apply to this information, please contact the sender immediately. For any Piher Exports, Note: All products / technologies are EAR99 Classified commodities. Exports from the United States are in accordance with the Export Administration Regulations. Diversion contrary to US law is prohibited.

CONTACT

Piher Sensing Systems
Polígono Industrial Municipal
Vial T2, N°22
31500 Tudela
Spain
sales@piher.net

+34 948 820 450

Rev.180923 © 2023 Piher Sensors & Controls S.A.