

High-Voltage Latch for Automotive and Industrial Applications

FEATURES AND BENEFITS

- 2.7 to 26 V operation
- AEC-Q100 qualified
- Omnipolar and unipolar switch threshold options
- High and low sensitivity magnetic switch-point options
- Choice of output polarity
- Chopper stabilization
 - Low switch-point drift over temperature
 - Insensitive to physical stress
- Open-drain output
- Solid-state reliability
- Industry-standard packages and pinouts
- Reverse-voltage and short-circuit protection
- Low jitter

PACKAGES

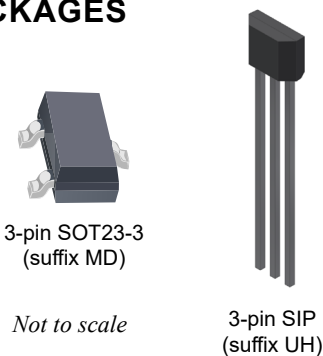

DESCRIPTION

The APS12203 high-voltage Hall-effect latch integrated circuits (ICs) are AEC-Q100 qualified for high-voltage automotive applications. These sensors are temperature-stable and suited for operation over extended junction temperature ranges up to 165°C. This family of Hall-effect latches provides contactless control of an open-drain output that actuates in response to a magnetic field applied to the branded package face. The device responds to a north or south polarity depending on device configuration. Additionally, the APS12203 includes a number of features to maximize system robustness, such as reverse-battery protection, output current limiting, and overvoltage protection.

These devices apply the chopper-stabilization technique, which reduces the residual offset typically caused by device overmolding, temperature dependencies, and thermal stress. This feature allows superior high-temperature performance.

The APS12203 is offered in Allegro package type MD-3, a standard 3-pin small-outline transistor (SOT23-3) surface-mount device (SMD) package, and UH-3, three-pin ultramini SIP for through-hole mounting. Both packages are lead (Pb) free.

APPLICATIONS

- Automotive: power closures, power steering, in-cabin motors, wiper position, gear-shift selectors, etc.
- Industrial: motor encoders, commutation/index sensing, brushless DC (BLDC) motors, fan motors,, etc.

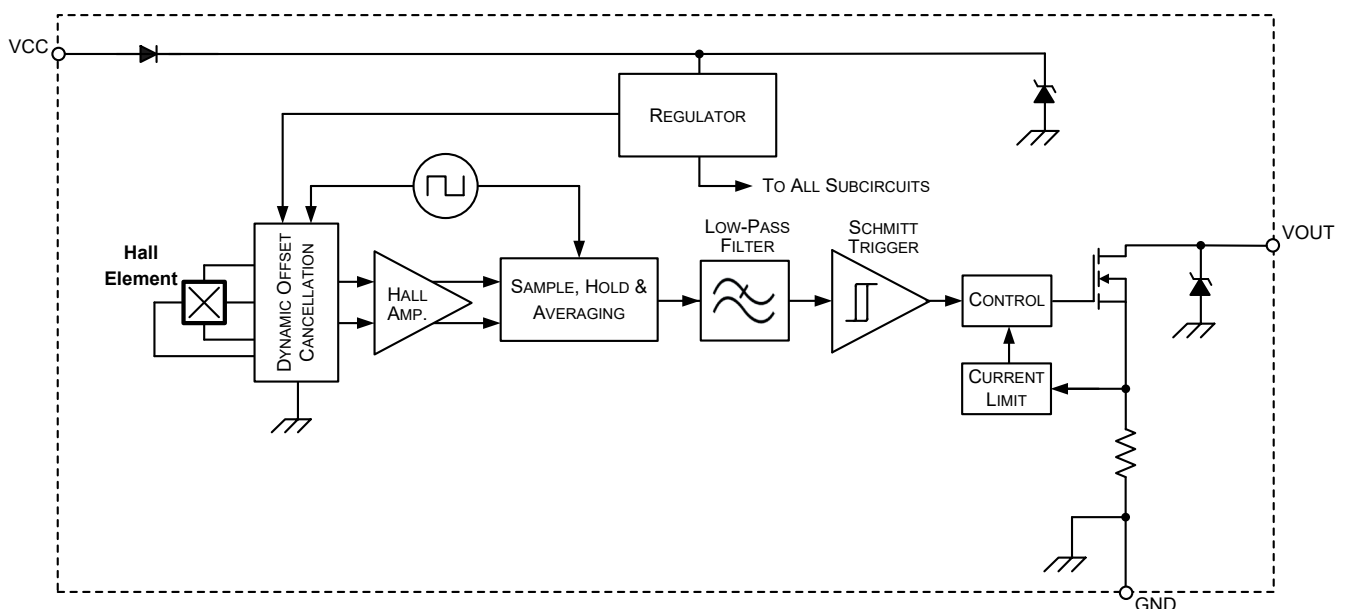

Figure 1: Functional Block Diagram

SPECIFICATIONS

SELECTION GUIDE

Part Number [1]	Typ. Switch Point Magnitude		Operating Temperature (°C)	Product Grade	Mounting	Packing [2]
	BOP (G)	BRP (G)				
APS12203LMDALX-0SL0	10	-10	-40 to 150	Automotive	3-pin SOT23-3 surface mount	Tape and reel, 10,000 pieces per 13-inch reel
APS12203LMDALX-2SL0	20	-20				
APS12203LMDALX-3SL0	30	-30				
APS12203LMDALX-4SL0	50	-50				
APS12203LMDALX-5SL0	95	-95				
APS12203LMDALX-6SL0	150	-150				
APS12203KMDALX-0SL0	10	-10	-40 to 125	Industrial	3-pin SOT23-3 surface mount	Tape and reel, 10,000 pieces per 13-inch reel
APS12203KMDALX-2SL0	20	-20				
APS12203KMDALX-3SL0	30	-30				
APS12203KMDALX-4SL0	50	-50				
APS12203KMDALX-5SL0	95	-95				
APS12203KMDALX-6SL0	150	-150				
APS12203LUHATN-0SL0	10	-10	-40 to 150	Automotive	3-pin SIP through hole	Tape and reel, 4,000 pieces per 13-inch reel
APS12203LUHATN-2SL0	20	-20				
APS12203LUHATN-3SL0	30	-30				
APS12203LUHATN-4SL0	50	-50				
APS12203LUHATN-5SL0	95	-95				
APS12203LUHATN-6SL0	150	-150				
APS12203KUHATN-0SL0	10	-10	-40 to 125	Industrial	3-pin SIP through hole	Tape and reel, 4,000 pieces per 13-inch reel
APS12203KUHATN-2SL0	20	-20				
APS12203KUHATN-3SL0	30	-30				
APS12203KUHATN-4SL0	50	-50				
APS12203KUHATN-5SL0	95	-95				
APS12203KUHATN-6SL0	150	-150				



[1] For options not listed in the selection guide, contact Allegro MicroSystems.

[2] For additional packing options, contact Allegro MicroSystems.

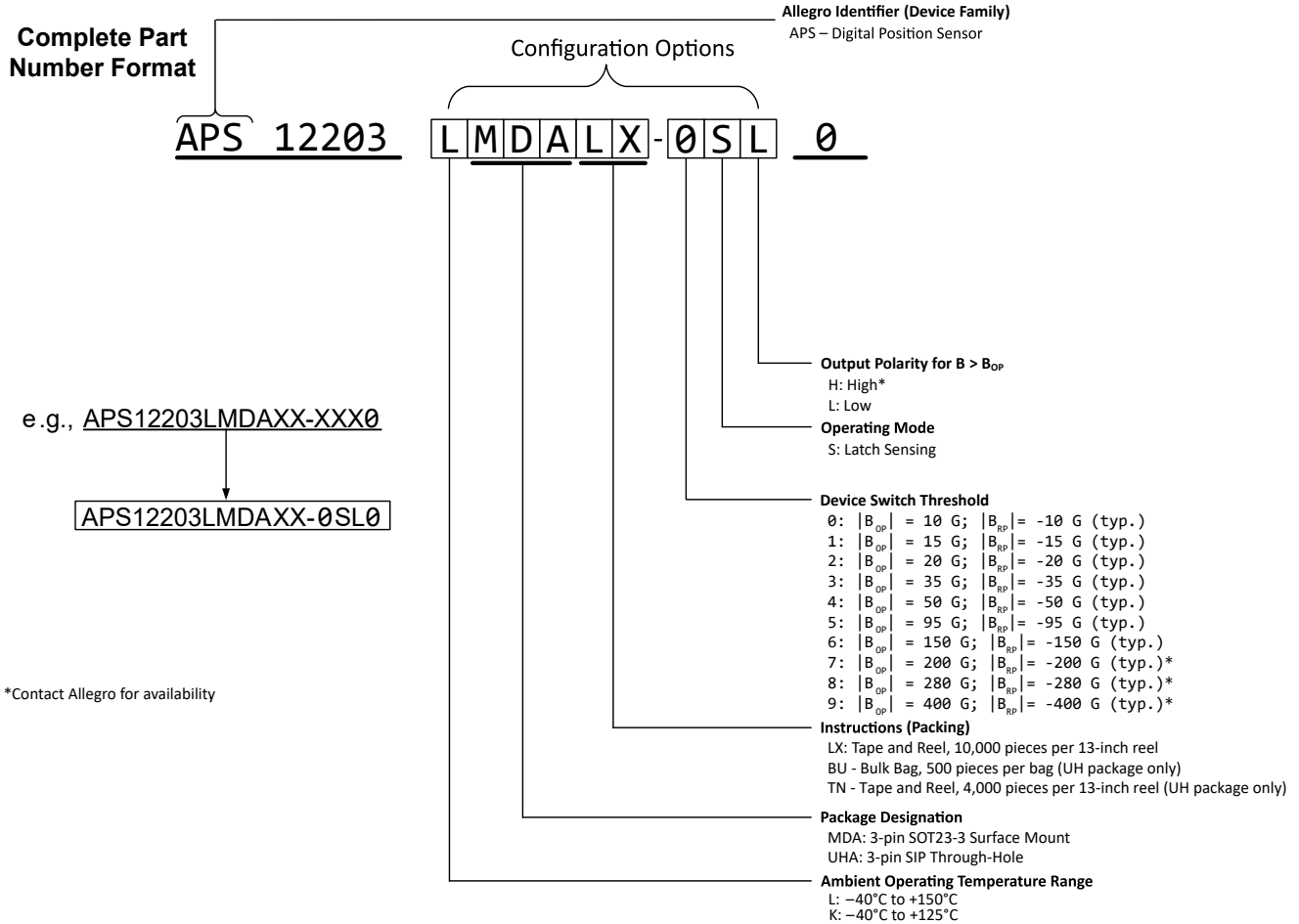

ABSOLUTE MAXIMUM RATINGS

Characteristic	Symbol	Notes	Rating	Units
Supply Voltage	V_{CC}		28	V
Reverse Supply Voltage	V_{RCC}		-18	V
Output Off Voltage	V_{OUT}		30	V
Output Current	I_{OUT}	Sink	30	mA
Operating Ambient Temperature	T_A	Range L	-40 to 150	°C
Maximum Junction Temperature	$T_{J(max)}$		165	°C
Storage Temperature	T_{stg}		-65 to 170	°C

THERMAL CHARACTERISTICS: May require derating at maximum conditions; see the Characteristic Performance section.

Characteristic	Symbol	Test Conditions	Value	Units
Package Thermal Resistance	$R_{\theta JA}$	Package MD, 2-layer PCB (1S0P)	309.2	°C/W
		Package MD, 4-layer PCB (2S2P)	197.9	°C/W
		Package UH, 1-layer PCB	270.6	°C/W

⁽¹⁾ Additional thermal information is available on the Allegro website.

ESD CHARACTERISTICS: Device power consumption is extremely low. Under typical operating conditions, on-chip power dissipation is not an issue.

Characteristic	Symbol	Test Conditions	Value	Units
HBM			7	kV
CDM			1	kV

PINOUT DIAGRAMS AND TERMINAL LIST

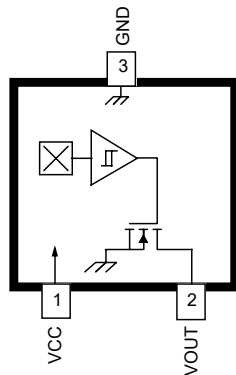

Figure 2: Package MD, 3-Pin SMD (SOT23-3)
(View From Branded Face)

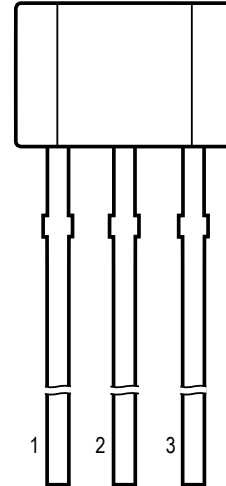

Figure 3: Package UH, 3-Pin Through-Hole
(View From Branded Face)

Terminal List Table

Number	Name	Function
1	VCC	Connection from power supply to chip
2	VOUT	Output from circuit
3	GND	Terminal for ground connection

TYPICAL APPLICATION CIRCUIT

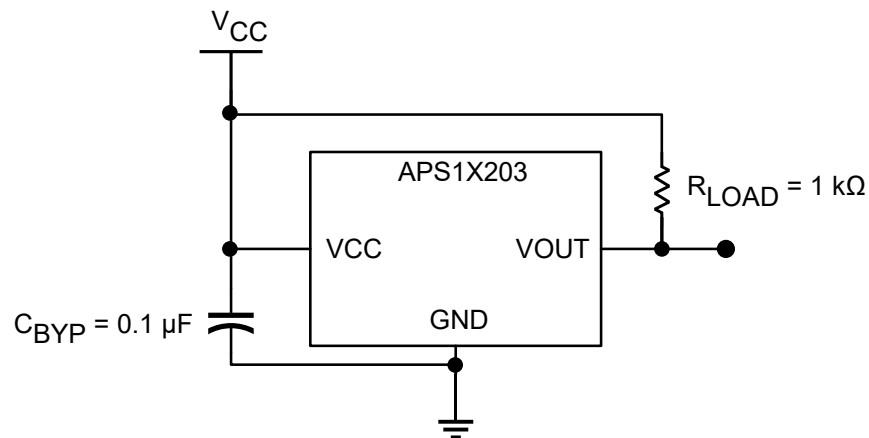

Figure 4: Typical Application Circuit

ELECTRICAL CHARACTERISTICS: Valid over full operating voltage and ambient temperature ranges for $T_J < T_{J(max)}$ and $C_{BYP} = 0.1 \mu F$, unless otherwise specified

Characteristics	Symbol	Test Conditions	Min.	Typ. [1]	Max.	Unit
SUPPLY AND STARTUP						
Supply Voltage	V_{CC}	Operating, $T_J < 165^\circ C$	2.7	–	26	V
Supply Current	I_{CC}		–	1.5	3	mA
Power-On Time [2]	t_{PO}	$V_{CC} > 2.7 V$ $B < B_{RP(min)} - 0.25 \times B_{RP(max)}$, $B > B_{OP(max)} + 0.25 \times B_{OP(max)}$	–	–	25	μs
Power-On State [2]	POS	$t < t_{PO}$, $V_{CC} \geq V_{CC(min)}$	Low			–
Reverse Battery Current	I_{RCC}	$V_{RCC} = -18 V$	–	–	–5	mA
CHOPPER STABILIZATION AND OUTPUT CHARACTERISTICS						
Chopping Frequency [2]	f_c		–	500	–	kHz
Propagation Delay [2]		$V_{CC} = 5 V$ Square-wave field with $B > B_{OP} + 30 G$	–	5	10	μs
Jitter [2]		60 poles ring magnet at 922 rpm $B = \pm 230 G$; 1σ value	–	320	–	ns
Output Rise Time [2]		$R_L = 820 \Omega$, $C_L = 20 pF$	–	–	2	μs
Output Fall Time [2]		$R_L = 820 \Omega$, $C_L = 20 pF$	–	–	2	μs
Output Saturation Voltage	$V_{OUT(SAT)}$	$I_{OUT} = 10 mA$ (sink)	–	–	500	mV
Output Short-Circuit Current Limit	I_{OM}		30	–	60	mA
Output Leakage Current	I_{OUTOFF}	$V_{OUT} = 26 V$, output state = high	–	–	10	μA

[1] Typical data is at $T_A = 25^\circ C$ and $V_{CC} = 12 V$ unless otherwise noted.

[2] Not tested in final production. Guaranteed by device characterization and design.

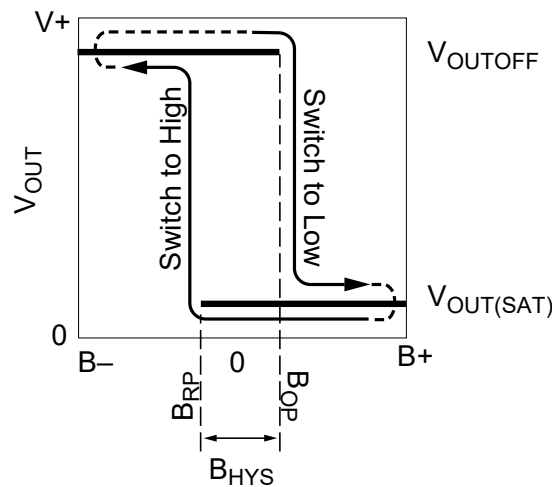

B_- indicates increasing north polarity magnetic field strength, and B_+ indicates increasing south polarity magnetic field strength.

Figure 5: Hall Latch Output State vs. Magnetic Field

MAGNETIC LATCH CHARACTERISTICS: Valid over full operating voltage and ambient temperature ranges for $T_J < T_{J(max)}$ and $C_{BYP} = 0.1 \mu F$, unless otherwise specified

Characteristics	Symbol	Test Conditions	Min.	Typ.	Max.	Unit
Operate Point	B_{OP}	-0xxx option	1	10	20	G
		-1xxx option	5	15	25	G
		-2xxx option	5	20	35	G
		-3xxx option	10	30	50	G
		-4xxx option	15	50	90	G
		-5xxx option	50	95	135	G
		-6xxx option	110	150	190	G
Release Point	B_{RP}	-0xxx option	-20	-10	-1	G
		-1xxx option	-25	-15	-5	G
		-2xxx option	-35	-20	-5	G
		-3xxx option	-50	-30	-10	G
		-4xxx option	-90	-50	-15	G
		-5xxx option	-135	-95	-50	G
		-6xxx option	-190	-150	-110	G
Hysteresis	B_{HYS}	-0xxx option	2	20	40	G
		-1xxx option	10	30	50	G
		-2xxx option	10	40	70	G
		-3xxx option	20	60	100	G
		-4xxx option	30	100	180	G
		-5xxx option	100	190	270	G
		-6xxx option	220	300	380	G

CHARACTERISTIC PERFORMANCE

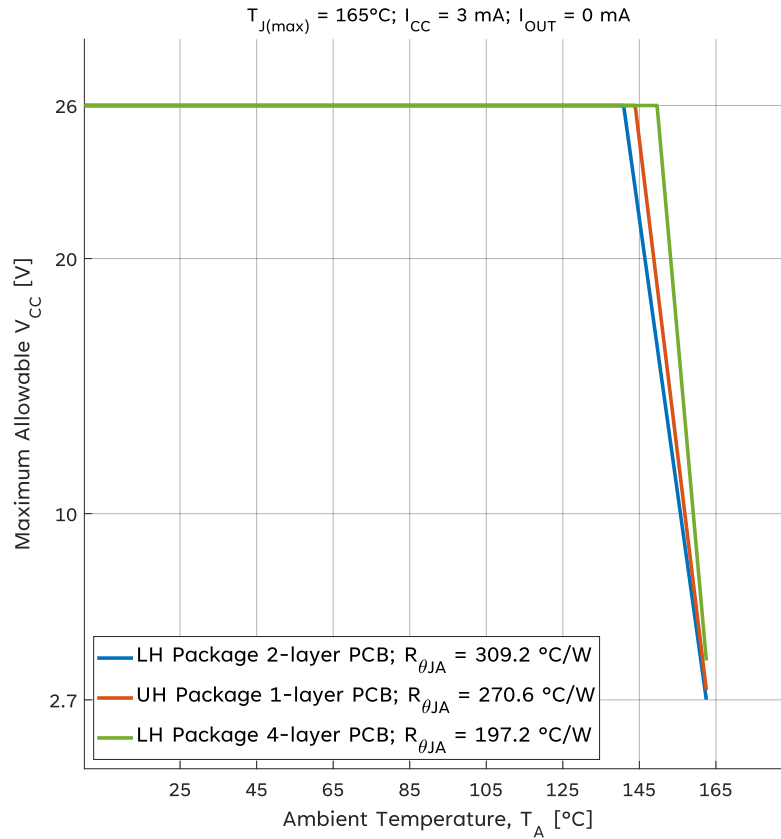

Figure 6: Power Derating

FUNCTIONAL DESCRIPTION

Operation

The APS12203 is an integrated Hall-effect sensor IC with a latch output. The output is an open-drain configuration that actuates in response to a magnetic field applied to the branded package face (see Figure 7). The devices are offered in a package with a 3-pin surface-mount configuration. For a complete list of available options, see the Selection Guide.

The output of these devices switches low when a magnetic field perpendicular to the Hall element exceeds the operate-point threshold, B_{OP} . After turn on, the output voltage is $V_{OUT(SAT)}$. When the magnetic field is reduced to less than the release point, B_{RP} , the device output turns off and is pulled high by the pull-up resistor.

The difference in the magnetic operate and release points is the hysteresis, B_{HYS} , of the device. This built-in hysteresis allows clean switching of the output, even in the presence of external mechanical vibration and electrical noise.

Device power-on occurs once t_{ON} has elapsed. During the time prior to t_{ON} and after $V_{CC} \geq V_{CC(min)}$, the output state is $V_{OUT(SAT)}$ (Low). After t_{ON} has elapsed, the output corresponds with the applied magnetic field for $B > B_{OP}$ or $B < B_{RP}$.

If a device power-on occurs in the hysteresis range (less than B_{OP} and greater than B_{RP}), the output state is $V_{OUT(OFF)}$. In this case, the correct state is attained after the first excursion beyond B_{OP} or B_{RP} .

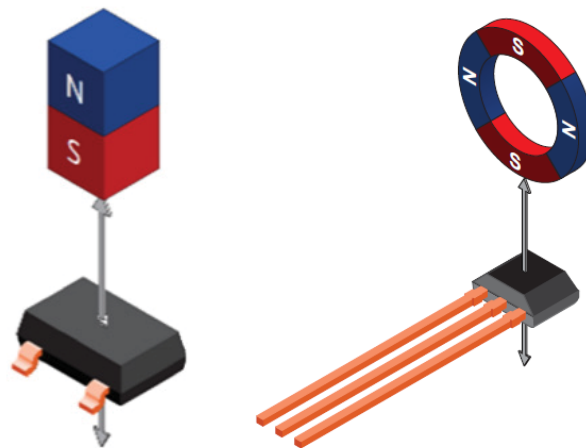

Figure 7: Magnetic-Sensing Orientations

CHOPPER STABILIZATION

A limiting factor for switch-point accuracy when using Hall-effect technology is the small-signal voltage developed across the Hall plate. This voltage is proportionally small relative to the offset that can be produced at the output of the Hall sensor. This makes it difficult to process the signal and maintain an accurate, reliable output over the specified temperature and voltage range. Chopper stabilization is a proven approach used to minimize the Hall offset.

The Allegro technique, dynamic quadrature offset cancellation, removes key sources of the output drift induced by temperature and package stress. This offset-reduction technique is based on a signal modulation-demodulation process implemented as shown in Figure 8.

The undesired offset signal is separated from the magnetically induced signal in the frequency domain through modulation. The subsequent demodulation acts as a modulation process for the

offset, causing the magnetically induced signal to recover its original spectrum at baseband while the DC offset becomes a high frequency signal. Then, using a low-pass filter, the signal passes while the modulated DC offset is suppressed. The innovative Allegro chopper-stabilization technique uses a high-frequency clock.

High-frequency operation allows a greater sampling rate that produces higher accuracy, reduced jitter, and faster signal processing. Additionally, filtering is more effective and results in a lower-noise analog signal at the sensor output. Devices that use this approach, such as the APS12203, have an extremely stable quiescent Hall output voltage, are immune to thermal stress, and have precise recoverability after temperature cycling. This technique is made possible through the use of a BiCMOS process that allows the use of low-offset and low-noise amplifiers in combination with high-density logic and sample-and-hold circuits.

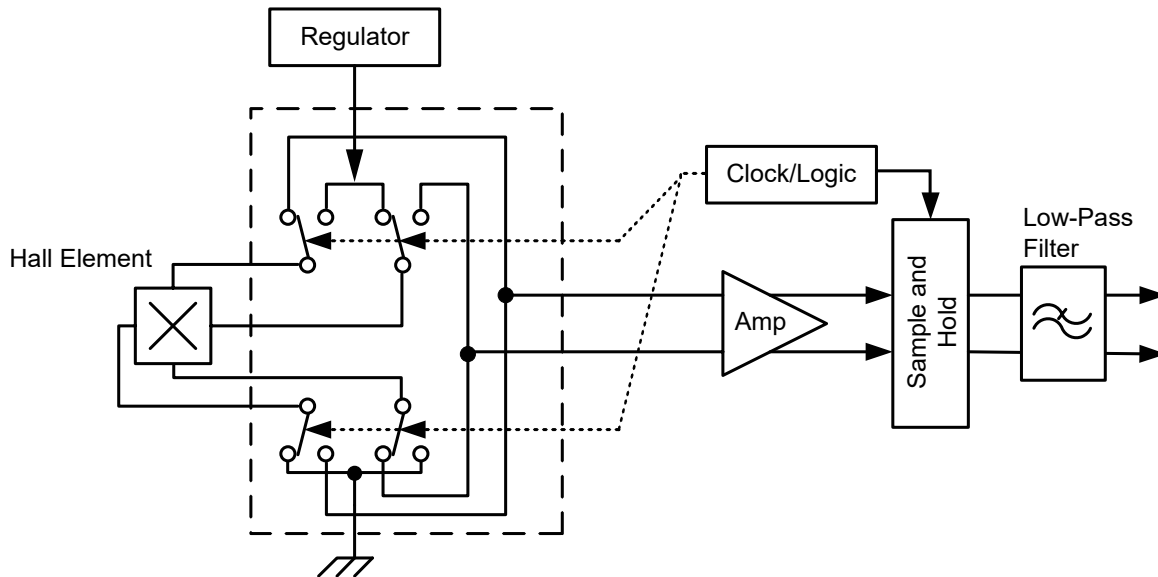

Figure 8: Model of Chopper Stabilization Circuit (Dynamic Offset Cancellation)

PACKAGE OUTLINE DRAWINGS

For Reference Only – Not for Tooling Use

(Reference Allegro DWG-0000930)

NOT TO SCALE

Dimensions in millimeters

Dimensions exclusive of mold flash, gate burrs, and dambar protrusions
Exact case and lead configuration at supplier discretion within limits shown

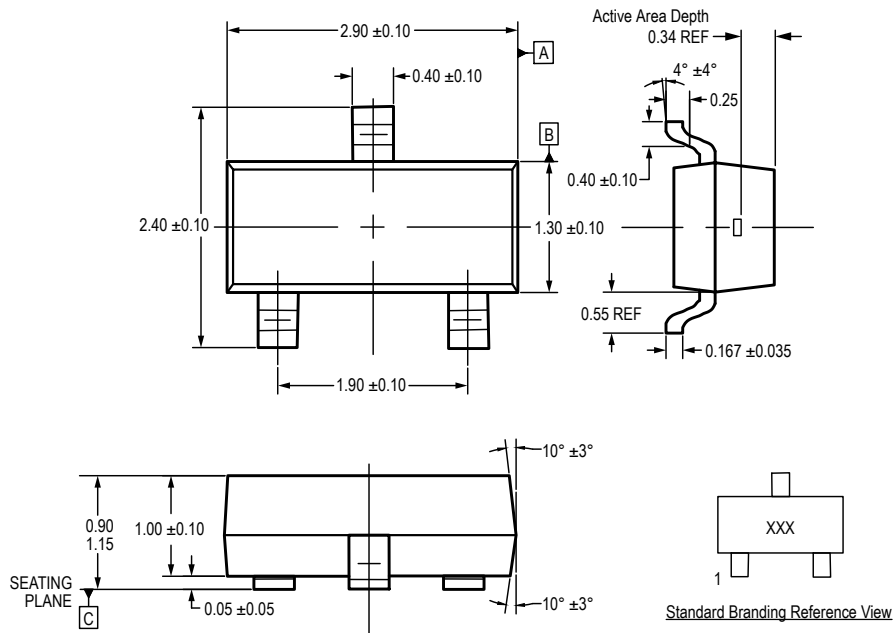

Figure 9: Package MD, 3-Pin SMD (SOT23-3)

For Reference Only – Not For Tooling Use

(Reference Allegro DWG-0000999)

NOT TO SCALE

Dimensions in millimeters

Exact case and lead configuration at supplier discretion within limits shown

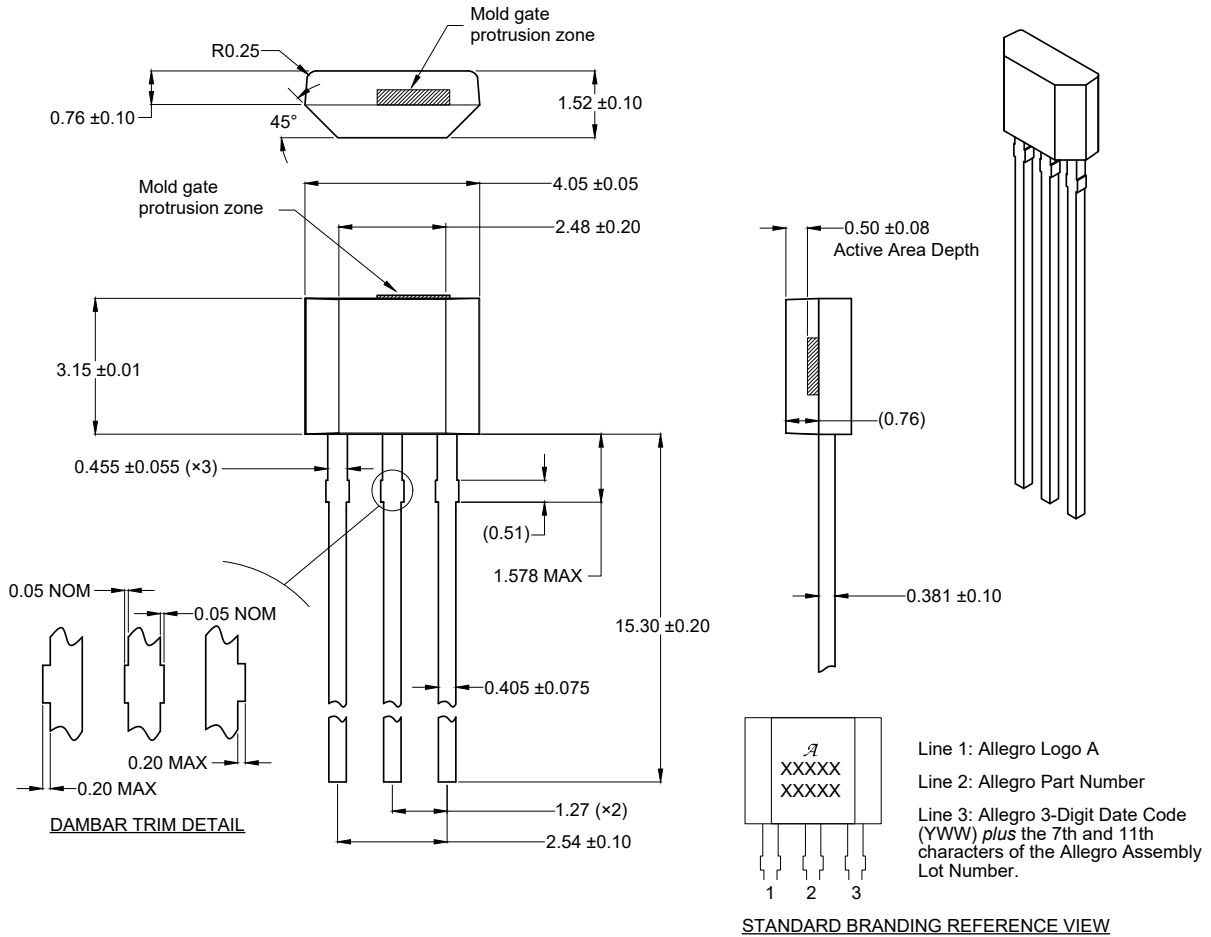

Figure 10: Package UH, 3-Pin Through-Hole

REVISION HISTORY

Number	Date	Description
–	May 27, 2025	Initial release
1	June 25, 2025	Updated selection guide table (page 2)
2	July 11, 2025	Modified jitter characteristic (page 5)
3	August 12, 2025	Modified selection guide table (page 2)
4	January 5, 2026	Corrected typo in date of Rev. 3 Revision History (pages 1 and 11); technical content not changed
5	February 20, 2026	Added UH-3 package variant and modified selection guide table (page 2)

Copyright 2026, Allegro MicroSystems.

Allegro MicroSystems reserves the right to make, from time to time, such departures from the detail specifications as may be required to permit improvements in the performance, reliability, or manufacturability of its products. Before placing an order, the user is cautioned to verify that the information being relied upon is current.

Allegro's products are not to be used in any devices or systems, including but not limited to life support devices or systems, in which a failure of Allegro's product can reasonably be expected to cause bodily harm.

The information included herein is believed to be accurate and reliable. However, Allegro MicroSystems assumes no responsibility for its use; nor for any infringement of patents or other rights of third parties which may result from its use.

Copies of this document are considered uncontrolled documents.

For the latest version of this document, visit our website:

www.allegromicro.com