

SCHRACK MINIATURE POWER PCB RELAY PB

GENERAL PURPOSE LOW POWER PCB RELAYS

FEATURES

- 1pole 10 A, 1 form C (CO) or 1 form A (NO)
- Environmentally-friendly cadmium-free contacts
- Class F coil system standard
- Compact and simple design gives high process security
- Plastic materials according to IEC 60335-1 (domestic appliances)

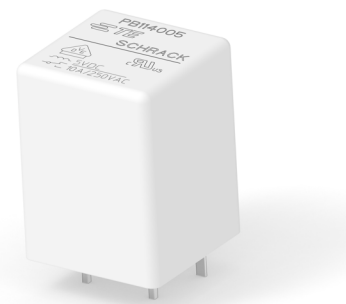

APPLICATIONS

- Heating control
- Interface technology
- Domestic appliances
- Timers
- Temperature control

APPROVALS

- VDE Cert. No. 40008364
- UL E214025



Technical data of approved types on request.

Miniature Power PCB Relay PB

Low Power PCB Relays

CONTACT DATA

Contact arrangement	1 form C (CO) or 1 form A (NO)
Rated voltage	250 VAC
Max. switching voltage	400 VAC
Rated current	10 A
Limiting making current, max 4 s, duty factor 10%	15 A
Breaking capacity max.	2500 VA
Contact material	AgNi 90/10, AgSnO ₂
Frequency of operation, with/without load	360/36000h-1
Operate/release time max.	10/20 ms
Bounce time max., form A/form B	10/15 ms

CONTACT RATINGS

Type	Contact	Load	Cycles
IEC 61810			
PB114; PB113	A/B (NO/NC)	10 A/3 A, 250 VAC, $\cos\phi=1$, 85 °C	30x10 ³
PB114; PB514	A of C	10 A, 250 VAC, $\cos\phi=1$, 85 °C	30x10 ³
PB134; PB133	A (NO)	10 A, 250 VAC, $\cos\phi=1$, 85 °C	20x10 ³
PB134	A (NO)	6.5 A, 440 VAC, $\cos\phi=1$, 85 °C	50x10 ³
PB634	A (NO)	10 A, 250 VAC, $\cos\phi=1$, 85 °C	100x10 ³
UL61810-1 (former UL 508)			
PB1x4	A (NO)	10 A, 250 VAC, $\cos\phi=1$, 85 °C	20x10 ³
PB113	A (NO)	10 A, 250 VAC GP, 85 °C	6x10 ³
PB5x4	A (NO)	10 A, 250 VAC GP, 85 °C	20x10 ³
PB634	A (NO)	10 A, 250 VAC GP, 85 °C	100x10 ³
Mechanical endurance, DC coil	5x10 ⁶ operations		

MAX. DC LOAD BREAKING CAPACITY

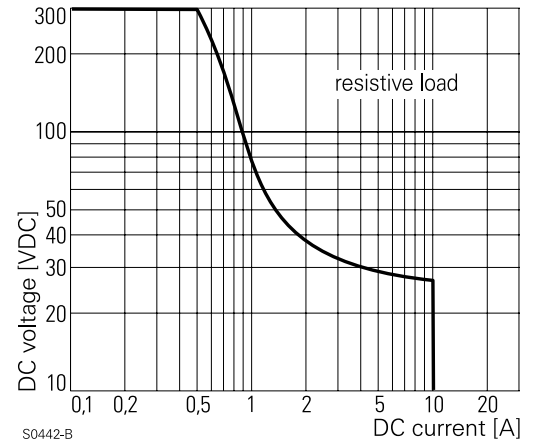

ELECTRICAL ENDURANCE

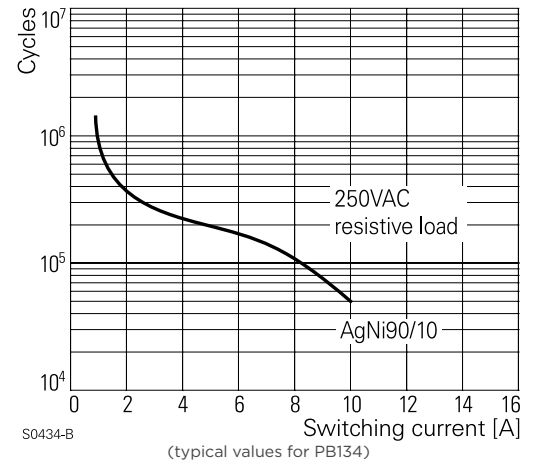

Miniature Power PCB Relay PB

Low Power PCB Relays

COIL DATA

	PB1	PB5	PB6
Coil voltage range	5 to 48 VDC	5 to 24 VDC	5 to 36 VDC
Operative range, IEC 61810	2	2	2

COIL VERSIONS, DC-COIL

Coil code	Rated voltage VDC	Operate voltage VDC	Release voltage VDC	Coil resistance $\Omega \pm 10\%$	Rated coil power mW
Coil versions, DC-coil, 360 mW					
005	5	3.75	0.5	70	357
006	6	4.50	0.6	100	360
009	9	6.75	0.9	225	360
012	12	9.00	1.2	400	360
018	18	13.50	1.8	900	360
022	22	16.50	2.2	1344	360
024	24	18.00	2.4	1600	360
048	48	36.00	4.8	6400	360
Coil versions, DC-coil, 500 mW					
005	5	3.75	0.5	48	521
006	6	4.5	0.6	69	522
012	12	9	1.2	274	526
024	24	18	2.4	1097	525
036	36	27	3.6	2592	500

All figures are given for coil without pre-energization, at ambient temperature +23 °C.

COIL OPERATING RANGE DC

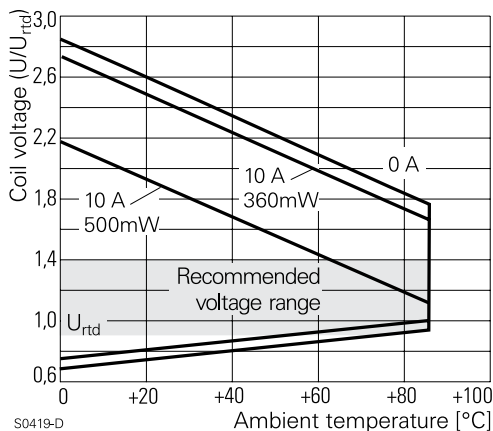

Other coil voltages on request.

INSULATION DATA

Initial dielectric strength	
Between open contacts	1000 Vrms
Between contact and coil	2500 Vrms
Clearance/creepage	
Between contact and coil	
Form C (CO) version	$\geq 3/4$ mm
Form A (NO) version	$\geq 4/5$ mm
Material group of insulation parts	IIIa
Tracking index of relay base	PTI250

OTHER DATA

Material compliance	EU RoHS/ELV, China RoHS, REACH, Halogen content refer to the Product Compliance Support Center at www.te.com/customer-support/rohssupportcenter
Resistance to heat and fire version PB1, PB5	according EN60335, par.30
Ambient temperature, DC coil	-40 to +85 °C
Category of environmental protection	
IEC 61810	RTII - flux proof
Vibration resistance (functional), form A/form B, 30 to 400 Hz	
PB1, PB6	> 10/4 g
PB5	> 10/6 g
Shock resistance (destructive)	> 100 g
Terminal type	PCB-THT
Weight	5.4 g
Resistance to soldering heat THT	
IEC 60068-2-20	270 °C/ 10 s
Packaging/unit	tube/35 pcs., box/1050 pcs.

Miniature Power PCB Relay PB

Low Power PCB Relays

DIMENSIONS (Unit: mm)

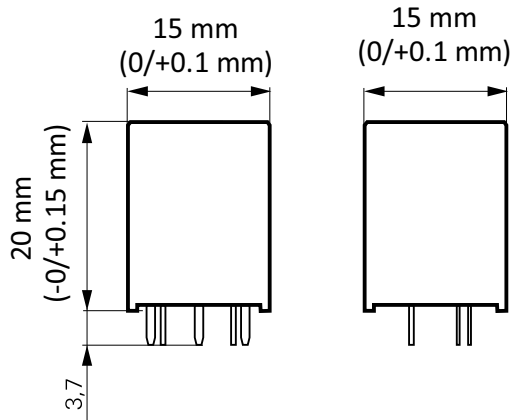

PCB LAYOUT¹⁾/ TERMINAL ASSIGNMENT

Bottom view on solder pins

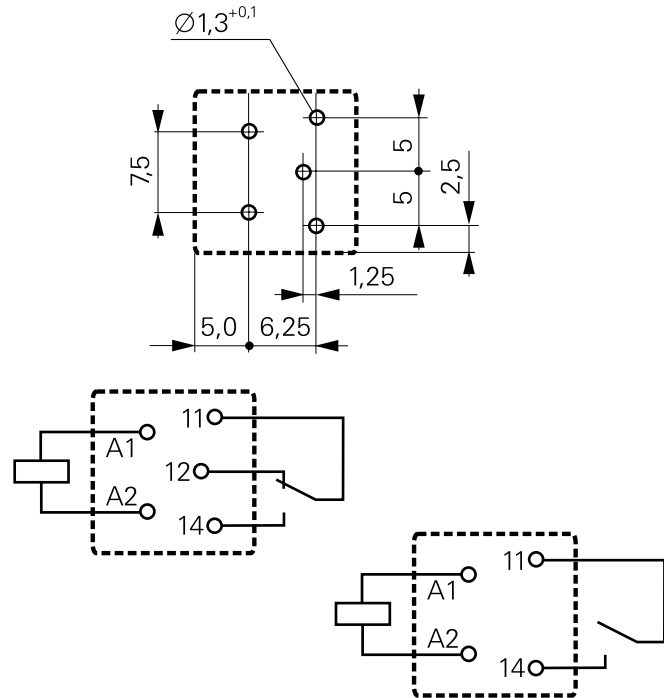

1) Layout note:

No openings (e.g. holes, slots, cutouts, unused pins, open through connections, etc.) allowed under the relay base. The relay base must be fully covered by the PCB, recommended minimum distance between the relay and the edge of the printed circuit board is 5 mm. For more information, please contact our application support.

ORDERING INFORMATION

Part Number
PB 1 1 4 012

Type

PB	Miniature Power PCB Relay PB
-----------	------------------------------

Version

1	Standard version
5	500 mW version
6	High performance version (form A version only)

Contact arrangement

1	1 form C contact (1 CO)
3	1 form A contact (1 NO)

Coil

Coil code: please refer to coil versions table

Contact material

3	AgSnO ₂
4	AgNi 90/10

Other types on request.

PRODUCT INFORMATION

Product code	Version	Contact configuration	Contact material	Coil	Part Number
PB114005	Standard class F	1 form C 1 CO contact	AgNi 90/10	5 VDC	6-1415029-1
PB114006				6 VDC	7-1415029-1
PB114012				12 VDC	8-1415029-1
PB114024				24 VDC	9-1415029-1
PB134005		1 form A 1 NO contact		5 VDC	1415030-1
PB134006				6 VDC	1-1415030-1
PB134012				12 VDC	2-1415030-1
PB134024				24 VDC	3-1415030-1
PB514012	500 mW version	1 form C 1 CO contact		12 VDC	2-1415538-5
PB634012	High performance version	1 form A 1 NO contact		12 VDC	4-1415541-1

te.com

©2026 TE Connectivity plc. family of companies. All Rights Reserved.

TE Connectivity, SCHRACK, TE connectivity (logo) and Every Connection Counts are trademarks owned or licensed by the TE Connectivity plc. family of companies. All other logos, products and/or company names referred to herein might be trademarks of their respective owners.

While TE has made every reasonable effort to ensure the accuracy of the information in this document, TE does not guarantee that it is error-free, nor does TE make any other representation, warranty or guarantee that the information is accurate, correct, reliable or current. TE reserves the right to make any changes to the information contained herein without prior notice. TE Connectivity assumes only those obligations set forth in the terms and conditions for this product and shall in no event be liable for any incidental, indirect, or consequential damages arising out of the sale, resale, use, or misapplication of the product. TE expressly disclaims any implied warranties with respect to the information contained herein, including, but not limited to, implied warranties of merchantability or fitness for a particular purpose. Dimensions, specifications and/or information contained herein are for reference purposes only and are subject to change without notice. Consult TE for the latest dimensions, specifications and/or information. Users of TE Connectivity products must make their own assessment as to whether the respective product is suitable for the respective desired application.

03/26 ED