

*for 12, 14 and 19 pol = 6,7

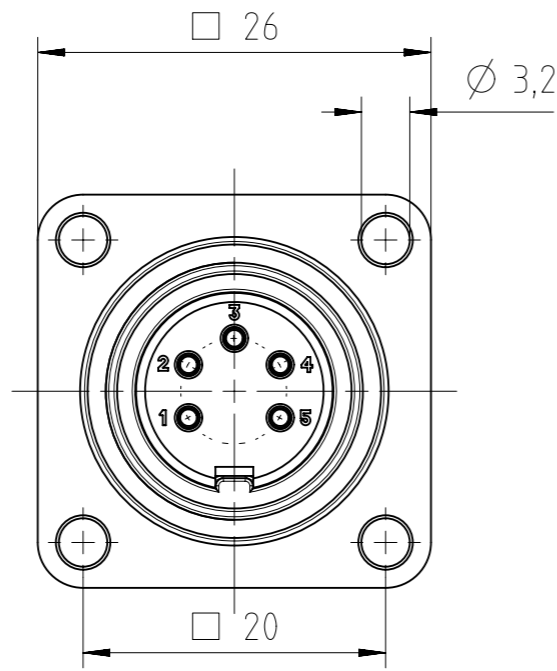

Panel Cutout M1:1

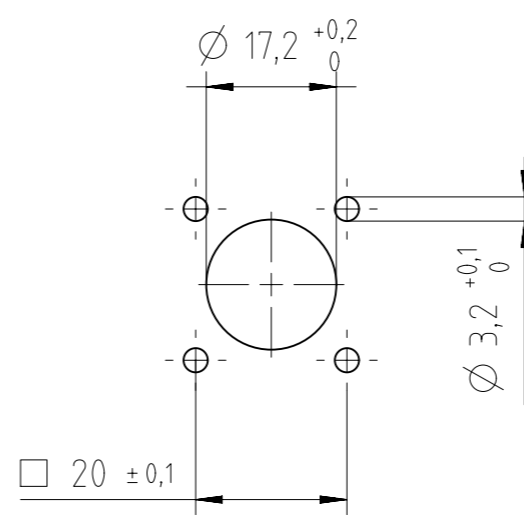

Sealing area must be flat and polished.
provide suitable sealing for the screws

Number of contacts	Standard	3	4	5	5	6	7	7	8	12	14	14	19	
Contact arrangement	IEC 61076-2-106	03-a	04-a	05-a	05-b	06-a	07-a	07-b	08-a	12-a	14-a	14-b	19-a	
Contact arrangement	IEC 60130-9 ⁹⁾	yes		no		yes		no		no				
Rated voltage ²⁾	IEC 60664-1	300 V (100 V)		300 V (63 V)		100 V (32 V)		300 V (63 V)		100 V (32 V)		150 V (32 V) 60 V (32 V)		
Rated voltage	UL 1977	250V								60V				
Rated impulse withstand voltage ²⁾	IEC 60664-1	1500 V (1500 V)		1200 V (800 V)		1500 V (1500 V)		1200 V (800 V)						
Pollution degree ²⁾	IEC 60664-1	1 (3 ³⁾)												
Installation category	IEC 60664-1	I												
Insulation group	IEC 60664-1	II, 400 ≤ CTI < 600												
Current rating	IEC 60512-5-2 UL 1977	10A/+40°C			7A/+40°C					3A/+40°C				
Insulation resistance	IEC 60512-3-1	>10 ¹⁰ Ohm ⁴⁾												
Contact resistance	IEC 60512-2-1	<5mOhm												
Climatic category	IEC 60668-1	40 / 100 / 56												
Temperatur range	IEC 60668-1	-40°C...+100°C / -40°F...+212°F												
Salt spray resistance	DIN IEC 60068-2-11, test Ka	720h												
IP degree	IEC 60529	IP 69K / IP 67 / IP 65 (in mated condition)												
Insertion and withdrawal force	IEC 60512-13-2	25N	30N	35N	35N	50N	55N	55N	60N	50N	50N	50N	60N	
mechanical operation	IEC 60512-9-1	Silver ≥500 mating cycles / Gold ≥1000 mating cycles												
housing material		brass and / or zinc die cast, nickel plated												
dielectric material		thermoplastic												
sealing material		Chloroprene												
contacts		silver or gold plated												
termination technique		solder												
wire gauge		≤0,5mm ² / 20 AWG								≤0,35mm ² / 22 AWG				
flamability		UL 94 V0												
locking system	IEC 60130-9 DIN EN 61076-2-106	metal screw coupling; tightening torque 0,7 - 1,5 Nm												

	19 (19-a)	Ag	C091 31S019 100 2 U
		Au	C091 31S019 200 2 U
	14 (14-b)	Ag	C091 31S114 100 2 U
		Au	C091 31S114 200 2 U
	14 (14-a)	Ag	C091 31S014 100 2 U
		Au	C091 31S014 200 2 U
	12 (12-a)	Ag	C091 31S012 100 2 U
		Au	C091 31S012 200 2 U
	8 (08-a)	Ag	C091 31S008 100 2 U
		Au	C091 31S008 200 2 U
	7 (07-b)	Ag	C091 31S107 100 2 U
		Au	C091 31S107 200 2 U
	7 (07-a)	Ag	C091 31S007 100 2 U
		Au	C091 31S007 200 2 U
	6 (6-a)	Ag	C091 31S006 100 2 U
		Au	C091 31S006 200 2 U
	5 (05-b)	Ag	C091 31S105 100 2 U
		Au	C091 31S105 200 2 U
	5 (05-a)	Ag	C091 31S005 100 2 U
		Au	C091 31S005 200 2 U
	4 (04-a)	Ag	C091 31S004 100 2 U
		Au	C091 31S004 200 2 U
	3 (03-a)	Ag	C091 31S003 100 2 U
		Au	C091 31S003 200 2 U
	2 (Pin 1+3)	Ag	C091 31S002 200 2 U
		Au	C091 31S002 200 2 U
	06	Contact arrangement View on mating side	
		Number of contacts (Contact arrangement acc. DIN EN 61076-2-106)	Part number

Gewicht (errechnet) / Calc WT: 18,74 g		Zul. Abw./Tolerances:		Maßstab / Scale: 2:1		A3	
Prüfmaß / Testdimension		ISO 2768-c		DIN / ISO 13715		CUSTOMER DRAWING	
Teileindex / Partindexnumber:		Gez. 07.07.2016		Drawn RSCHADEL		Male receptacle	
Bagatelle change:		Status Released		Gepr. 07.09.2023		flange mounting	
		Checked MCARLE		Gepr. 07.07.2016		M C091 31SXXX X00 2 U	
06 202300020 07.09.2023 MKELB		Amphenol Tuchel Industrial GmbH		Blatt / Sheet 1		1 Bl.	
05 202000083 26.10.2020 MCARL				Ers. f. l. Replacement for: M-C091 31SXXX X00 2 U Rev02		NXM-V05	
04 201800085 04.07.2018 MBERT							
03 201600320 07.07.2016 RSCHA							
Index Änderung / Description Datum / Date Name							

⁹⁾ Edition 2000-05
²⁾ values in brackets are according to DIN EN 61076-2-106
³⁾ designed acc. pollution degree 2, can be used under pollution degree 3 when the rules of IEC 60644-1 are fulfilled
⁴⁾ under operating conditions >10⁸ Ohm
 Do not connect or disconnect under load Metal housing parts shall be securely incorporated to protected ground
 Remark for gold plated contacts:
 In order to avoid brittle inter-metallic connections, gold plated terminals have to be tin-plated in the solder area.
 All technical data have been measured in a laboratory environment and can be different during practical usage of the product. Any product information is for descriptive usage only and not legally binding, particularly the information does not constitute or provide any legal guaranties ("Beschaffungsgarantie" or "Haltbarkeitsgarantie").

Coping of this document and giving it to others and the use or communication of the contents thereof, are forbidden without express authority. Offenders are liable to the payment of damages. All rights are reserved in the event of the grant of a patent or the registration of the utility model or design.
 Weitergabe sowie Vervielfältigung dieser Unterlage, Verwertung und Mitteilung ihres Inhalts nicht gestattet, soweit nicht ausdrücklich zugestanden. Zuwiderhandlungen verpflichten zu Schadensersatz. Alle Rechte für den Fall der Patenterteilung oder Gebrauchsmuster-Eintragung vorbehalten.