

# Data Sheet | Item Number: 2092-1123

1-conductor female connector; push-button; Push-in CAGE CLAMP®; 2.5 mm²; Pin spacing 5 mm; 3-pole; 2,50 mm²; light gray

<https://www.wago.com/2092-1123>



Color: ■ light gray

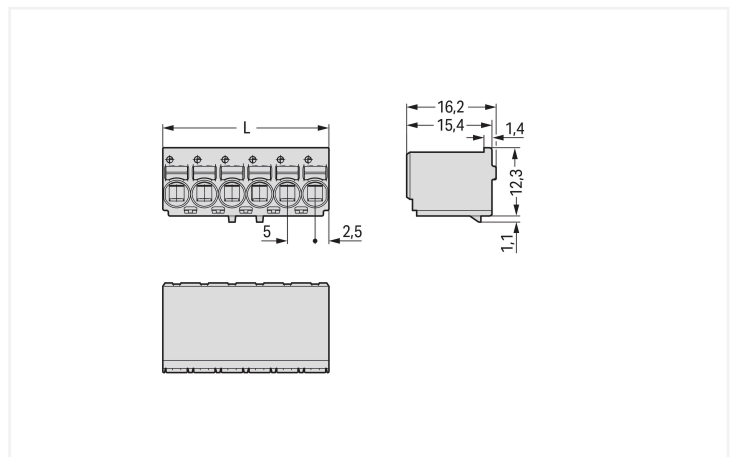
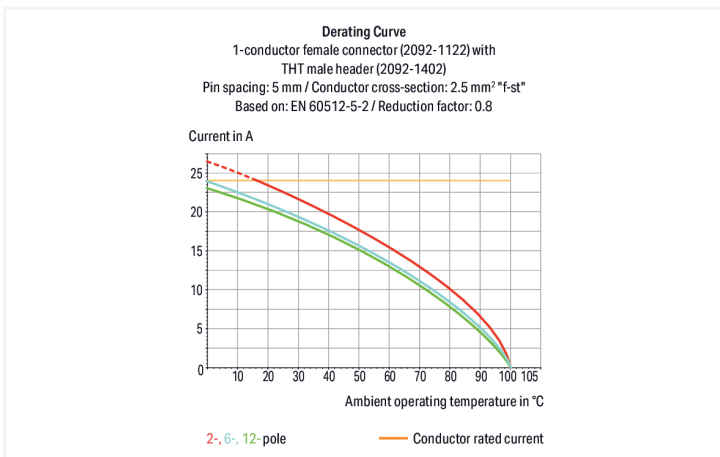

Female connector, 2092 Series, light gray

Convenient electrical installations are guaranteed with this female connector (item number 2092-1123). Strip lengths must be between 9 and 10 mm when connecting conductors to this female connector. Featuring one conductor terminal along with Push-in CAGE CLAMP®, this connector is highly versatile. Push-in CAGE CLAMP® technology provides a universal connection solution for all conductor types. It allows both solid and fine-stranded

conductors with ferrules to be inserted directly into the clamping point without the need for tools. The dimensions are (15 x 16.2 x 13.4) mm (width x height x depth). This female connector is suitable for conductor cross sections ranging from 0.2 mm<sup>2</sup> to 2.5 mm<sup>2</sup>.

The contact surface is coated with tin.

## Notes

### Safety Information

The **picoMAX® Pluggable Connection System** includes connectors without breaking capacity in accordance with DIN EN 61984. When used as intended, these connectors must not be connected/disconnected when live or under load. When used as intended, these connectors must not be connected/disconnected when live or under load. The circuit design should ensure header pins, which can be touched, are not live when un-mated.

### Safety information 2

The use of ferrules is recommended for applications with higher requirements.

To prevent excessive force on the clamping point, effective cable strain relief must be used.

### Variants:

Direct marking  
Other versions (or variants) can be requested from WAGO Sales or configured at <https://configurator.wago.com/>.

## Electrical data

Ratings per	IEC/EN 60664-1		
	III	III	II
Overvoltage category	III	III	II
Pollution degree	3	2	2
Nominal voltage	250 V	320 V	630 V
Rated impulse withstand voltage	4 kV	4 kV	4 kV
Rated current	16 A	16 A	16 A

Approvals per	UL 1059		
	B	C	D
Use group	B	C	D
Rated voltage	300 V	-	300 V
Rated current	15 A	-	10 A

## Connection Data

Clamping units	3
Total number of potentials	3
Number of connection types	1
Number of levels	1

### Connection 1

Connection technology	Push-in CAGE CLAMP®
Actuation type	Push-button
Actuation direction 1	Operation parallel to conductor entry
Solid conductor	0.2 ... 2.5 mm <sup>2</sup> / 24 ... 12 AWG
Fine-stranded conductor	0.2 ... 2.5 mm <sup>2</sup> / 24 ... 12 AWG
Fine-stranded conductor; with insulated ferrule	0.25 ... 1.5 mm <sup>2</sup>
Fine-stranded conductor; with uninsulated ferrule	0.25 ... 2.5 mm <sup>2</sup>
Strip length	9 ... 10 mm / 0.35 ... 0.39 inches
Pole number	3

## Physical data

Pin spacing	5 mm / 0.197 inches
Width	15 mm / 0.591 inches
Height	16.2 mm / 0.638 inches
Depth	13.4 mm / 0.528 inches

### Mechanical data

Variable coding	Yes
Anti-rotation protection	Yes

### Plug-in connection

Contact type (pluggable connector)	Female connector/socket
Connector (connection type)	for conductor
Mismating protection	No
Plugging without loss of pin spacing	Yes

### Material data

Note (material data)	<a href="#">Information on material specifications can be found here</a>
Color	light gray
Material group	I
Insulation material (main housing)	Polyphthalamide (PPA GF)
Flammability class per UL94	V0
Clamping spring material	Chrome-nickel spring steel (CrNi)
Contact material	Electrolytic copper (E <sub>Cu</sub> )
Contact Plating	Tin
Fire load	0.031 MJ
Weight	2.7 g

### Environmental requirements

Limit temperature range	-60 ... +100 °C
Processing temperature	-35 ... +60 °C

### Commercial data

Product Group	26 (picoMAX Connectors)
PU (SPU)	200 pcs
Packaging type	Box
Country of origin	DE
GTIN	4050821163480
Customs tariff number	85366990990

### Product Classification

UNSPSC	39121409
eCl@ss 10.0	27-14-11-06
eCl@ss 9.0	27-14-11-06
ETIM 9.0	EC001284
ETIM 10.0	EC001284
ECCN	NO US CLASSIFICATION

**Environmental Product Compliance**

RoHS Compliance Status	Compliant, No Exemption
------------------------	-------------------------

**Approvals / Certificates**

**General approvals**



Approval	Standard	Certificate Name
CB DEKRA Certification B.V.	IEC 61984	NL-89885
CSA CSA Group	C22.2	2362521
CSA DEKRA Certification B.V.	C22.2 No. 158	2362521
cURus Underwriters Laboratories Inc.	UL 1059	E45172
KEMA/KEUR DEKRA Certification B.V.	EN 61984	71-129874
UL Underwriters Laboratories Inc.	UL 1977	E45171

**Downloads**

**Environmental Product Compliance**

Compliance Search	
Environmental Product Compliance 2092-1123	↓

**Documentation**

Additional Information			
Technical Section	03.04.2019	pdf 2027.26 KB	↓

**CAD/CAE-Data**

CAD data	
2D/3D Models 2092-1123	↓

CAE data	
ZUKEN Portal 2092-1123	↓

## 1 Compatible Products

### 1.1 System counterpart

#### 1.1.1 Male connector/plug



**Item No.: 2092-1523/020-000**  
1-conductor male connector; Push-in CAGE CLAMP®; 2.5 mm<sup>2</sup>; Pin spacing 5 mm; 3-pole; DIN-35 rail/panel mounting; Snap-in mounting feet; Integrated release lever; 2,50 mm<sup>2</sup>; light gray



**Item No.: 2092-1503/002-000**  
1-conductor male connector; Push-in CAGE CLAMP®; 2.5 mm<sup>2</sup>; Pin spacing 5 mm; 3-pole; Gripping plate; 2,50 mm<sup>2</sup>; light gray



**Item No.: 2092-1523/002-000**  
1-conductor male connector; Push-in CAGE CLAMP®; 2.5 mm<sup>2</sup>; Pin spacing 5 mm; 3-pole; Integrated release lever; 2,50 mm<sup>2</sup>; light gray



**Item No.: 2092-1633/024-000**  
Panel feedthrough male connector; clamping collar; 2.5 mm<sup>2</sup>; 3-pole; Pin spacing 5 mm; light gray



**Item No.: 2092-1423/205-000**  
THR male header; 1.4 mm Ø solder pin; angled; clamping collar; Pin spacing 5 mm; 3-pole; light gray



**Item No.: 2092-1423/200-000/997-406**  
THR male header; 1.4 mm Ø solder pin; angled; in tape-and-reel packaging; Pin spacing 5 mm; 3-pole; light gray



**Item No.: 2092-1423/200-000**  
THR male header; 1.4 mm Ø solder pin; angled; Pin spacing 5 mm; 3-pole; light gray



**Item No.: 2092-1403/205-000**  
THR male header; 1.4 mm Ø solder pin; straight; clamping collar; Pin spacing 5 mm; 3-pole; light gray



**Item No.: 2092-1403/200-000**  
THR male header; 1.4 mm Ø solder pin; straight; Pin spacing 5 mm; 3-pole; light gray



**Item No.: 2092-1723/200-000**  
THR pin strip; 1.4 mm Ø solder pin; angled; Pin spacing 5 mm; 3-pole; black



**Item No.: 2092-1703/200-000**  
THR pin strip; 1.4 mm Ø solder pin; straight; Pin spacing 5 mm; 3-pole; black



**Item No.: 2092-1423/005-000**  
THT male header; 1.4 mm Ø solder pin; angled; clamping collar; Pin spacing 5 mm; 3-pole; light gray



**Item No.: 2092-1423**  
THT male header; 1.4 mm Ø solder pin; angled; Pin spacing 5 mm; 3-pole; light gray



**Item No.: 2092-1403/005-000**  
THT male header; 1.4 mm Ø solder pin; straight; clamping collar; Pin spacing 5 mm; 3-pole; light gray



**Item No.: 2092-1403**  
THT male header; 1.4 mm Ø solder pin; straight; Pin spacing 5 mm; 3-pole; light gray



**Item No.: 2092-1723**  
THT pin strip; 1.4 mm Ø solder pin; angled; Pin spacing 5 mm; 3-pole; black



**Item No.: 2092-1703**  
THT pin strip; 1.4 mm Ø solder pin; straight; Pin spacing 5 mm; 3-pole; black

## 1.2 Optional Accessories

### 1.2.1 Ferrule

#### 1.2.1.1 Ferrule



**Item No.: 216-301**  
Ferrule; Sleeve for 0.25 mm<sup>2</sup> / AWG 24; insulated; electro-tin plated; yellow



**Item No.: 216-131**  
Ferrule; Sleeve for 0.25 mm<sup>2</sup> / AWG 24; uninsulated; electro-tin plated; silver-colored



**Item No.: 216-302**  
Ferrule; Sleeve for 0.34 mm<sup>2</sup> / 22 AWG; insulated; electro-tin plated; light turquoise



**Item No.: 216-132**  
Ferrule; Sleeve for 0.34 mm<sup>2</sup> / 22 AWG; uninsulated; electro-tin plated



**Item No.: 216-101**  
Ferrule; Sleeve for 0.5 mm<sup>2</sup> / AWG 22; uninsulated; electro-tin plated; silver-colored



**Item No.: 216-202**  
Ferrule; Sleeve for 0.75 mm<sup>2</sup> / 18 AWG; insulated; electro-tin plated; gray



**Item No.: 216-102**  
Ferrule; Sleeve for 0.75 mm<sup>2</sup> / AWG 20; uninsulated; electro-tin plated; silver-colored



**Item No.: 216-122**  
Ferrule; Sleeve for 0.75 mm<sup>2</sup> / AWG 20; uninsulated; electro-tin plated; silver-colored



**Item No.: 216-203**  
Ferrule; Sleeve for 1 mm<sup>2</sup> / AWG 18; insulated; electro-tin plated; red



**Item No.: 216-103**  
Ferrule; Sleeve for 1 mm<sup>2</sup> / AWG 18; uninsulated; electro-tin plated



**Item No.: 216-143**  
Ferrule; Sleeve for 1 mm<sup>2</sup> / AWG 18; uninsulated; electro-tin plated; electrolytic copper; gastight crimped; acc. to DIN 46228, Part 1/08.92



**Item No.: 216-204**  
Ferrule; Sleeve for 1.5 mm<sup>2</sup> / AWG 16; insulated; electro-tin plated; black

### 1.2.1.1 Ferrule



**Item No.: 216-144**

Ferrule; Sleeve for 1.5 mm<sup>2</sup> / AWG 16; un-insulated; electro-tin plated; electrolytic copper; gastight crimped; acc. to DIN 46228, Part 1/08.92; silver-colored

**Item No.: 216-104**

Ferrule; Sleeve for 1.5 mm<sup>2</sup> / AWG 16; un-insulated; electro-tin plated; silver-colored

**Item No.: 216-106**

Ferrule; Sleeve for 2.5 mm<sup>2</sup> / AWG 14; un-insulated; electro-tin plated; silver-colored

### 1.2.2 Strain relief

#### 1.2.2.1 Gripping plate



**Item No.: 2092-1601/002-000**

Gripping plate with sliding connector release; for female and male connectors; 2 parts; Pin spacing 5 mm; 3- to 4-pole; light gray

**Item No.: 2092-1601**

Gripping plate; for female and male connectors; 1 part; Pin spacing 5 mm; 3- to 4-pole; light gray

### 1.2.3 Test and measurement

#### 1.2.3.1 Testing accessories



**Item No.: 735-500**

WAGO Test pin; 1 mm Ø; 30 V AC / 60 V DC; CAT0; 1 A; 6 mm un-insulated; Test lead for soldering up to 0,5mm<sup>2</sup>

### 1.2.4 Tool

#### 1.2.4.1 Operating tool



**Item No.: 210-719**

Operating tool; Blade: 2.5 x 0.4 mm; with a partially insulated shaft

**Item No.: 2092-1630**

Unlocking tool; orange

### Installation Notes

#### Locking system

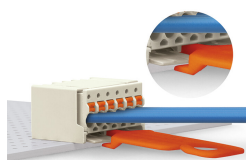

Disconnecting a female connector via unlocking tool. Plug unlocking tool into the male header's locking latch.

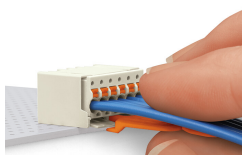

Insert unlocking tool until it hits the backstop. Wedge opens locking latches.

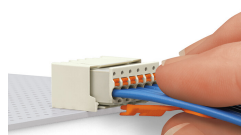

Pull on both unlocking tool and conductors to remove female connector from male header.

## Conductor termination

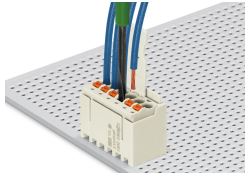

Inserting fine-stranded conductor into mated female connector via push-button.



Inserting a fine-stranded conductor into an unmated female connector via push-button.

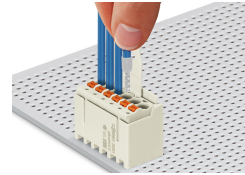

Inserting solid and ferruled conductors via push-in termination.

## Marking



Pole marking via factory direct marking.

## Coding



Coding a female connector (via coding key carrier and two keys for female connector, see symbol).

## Testing



Testing via 1 mm Ø test pin – touch contact.