

Notes 1 : Lead co-planality include reinforced metal fittings shall be 0.1mm MAX.
 2 If there are pattern and a via hole on part, there is a possibility that it will make contact with the leads.

Part No.	Number of Contacts	Code No.	A	B	C	D
DF13E-10DP-1.25V(52)	10	CL536-0566-0-52	12.10	5.00	7.50	8.70
DF13E-20DP-1.25V(52)	20	CL536-0567-0-52	18.35	11.25	13.75	14.95
DF13E-30DP-1.25V(52)	30	CL536-0568-0-52	24.60	17.50	20.00	21.20
DF13E-40DP-1.25V(52)	40	CL536-0569-0-52	30.85	23.75	26.25	27.45

NO.	MATERIAL	FINISH . REMARKS	NO.	MATERIAL	FINISH . REMARKS
2	Brass	Contact area:Gold plated 0.2µm min Lead plated:Tin plated 1µm min Under plating:Nickel 1µm min	6	Polyamide	Beige,UL94V-0
1	Polyamide	Beige,UL94V-0	5	Polyester	Clear(Cover tape)
			4	PS	Clear(Embossed carrier tape)
			3	Phosphor bronze	Tin plated 1µm min

UNITS	SCALE	COUNT	DESCRIPTION OF REVISIONS	DESIGNED	CHECKED	DATE
mm	5 : 1	△				

HRS HIROSE ELECTRIC CO., LTD.	APPROVED : HS. OKAWA	20200330	DRAWING NO.	EDC-367983-52-00
	CHECKED : TS. KUMAZAWA	20200330	PART NO.	DF13E-*DP-1.25V(52)
	DESIGNED : HK. HAYASHI	20200330	CODE NO.	CL536-
	DRAWN : DS. HIROWATARI	20200326		

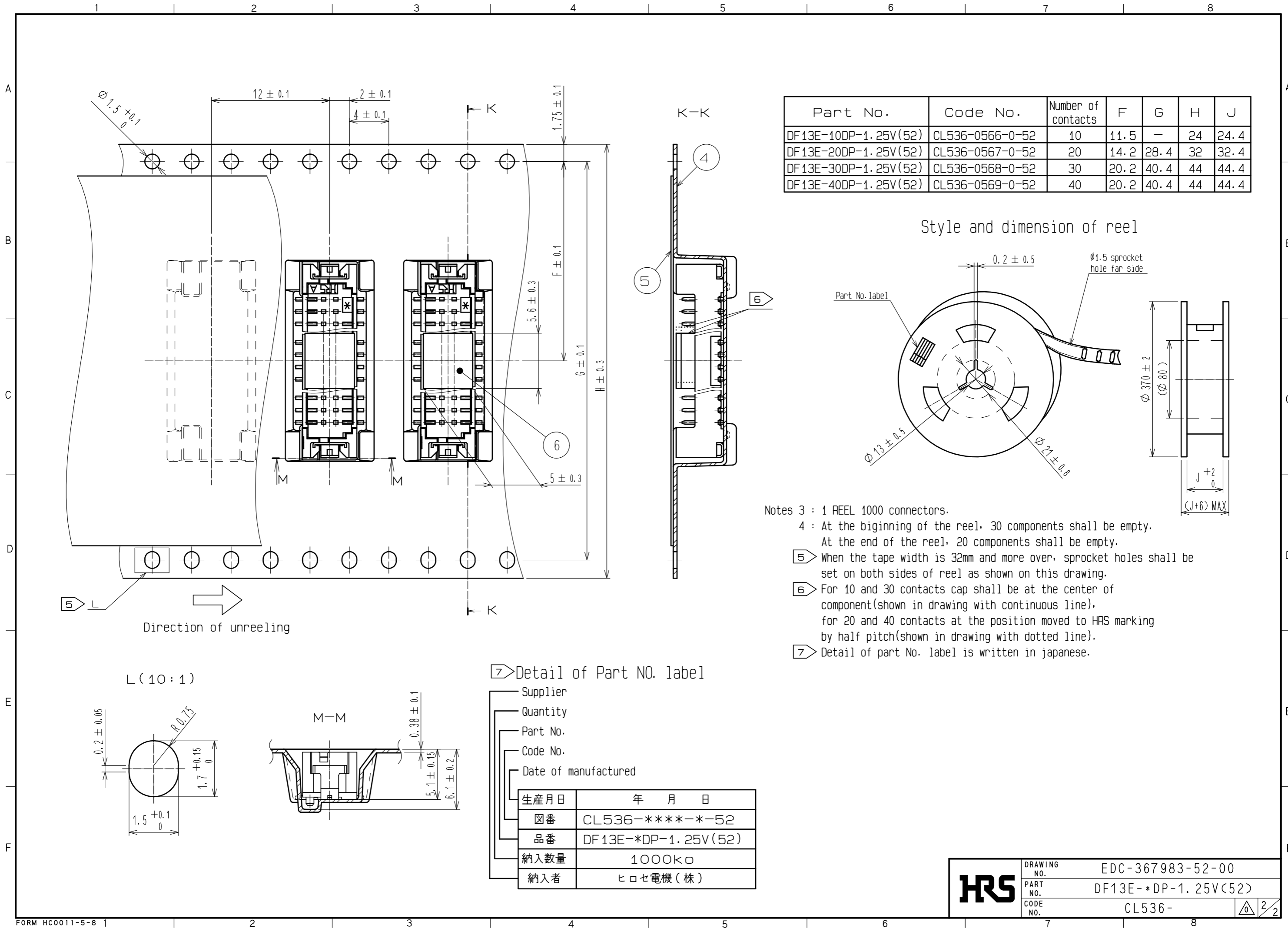

Part No.	Code No.	Number of contacts	F	G	H	J
DF13E-10DP-1.25V(52)	CL536-0566-0-52	10	11.5	-	24	24.4
DF13E-20DP-1.25V(52)	CL536-0567-0-52	20	14.2	28.4	32	32.4
DF13E-30DP-1.25V(52)	CL536-0568-0-52	30	20.2	40.4	44	44.4
DF13E-40DP-1.25V(52)	CL536-0569-0-52	40	20.2	40.4	44	44.4

Style and dimension of reel

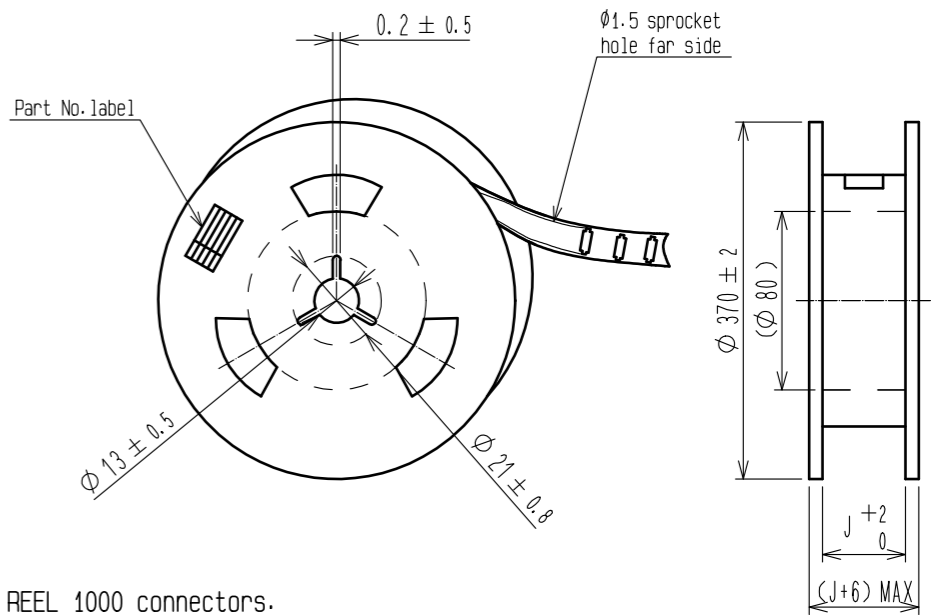

- Notes 3 : 1 REEL 1000 connectors.
 4 : At the beginning of the reel, 30 components shall be empty.
 At the end of the reel, 20 components shall be empty.
 5 When the tape width is 32mm and more over, sprocket holes shall be set on both sides of reel as shown on this drawing.
 6 For 10 and 30 contacts cap shall be at the center of component (shown in drawing with continuous line), for 20 and 40 contacts at the position moved to HRS marking by half pitch (shown in drawing with dotted line).
 7 Detail of part No. label is written in Japanese.

7 Detail of Part NO. label

Supplier	
Quantity	
Part No.	
Code No.	
Date of manufactured	
生産月日	年 月 日
図番	CL536-****-*-52
品番	DF13E-*DP-1.25V(52)
納入数量	1000k \square
納入者	ヒロセ電機(株)

HRS	DRAWING NO.	EDC-367983-52-00
	PART NO.	DF13E-*DP-1.25V(52)
	CODE NO.	CL536-
		2/2