

**Top View of Assembly**

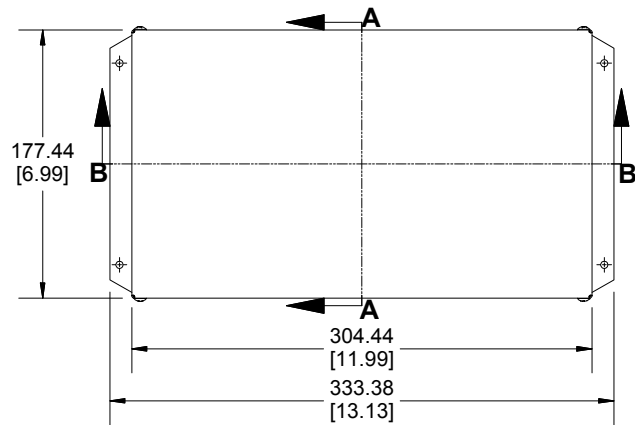

**SECTION A-A  
End View of Assembly**

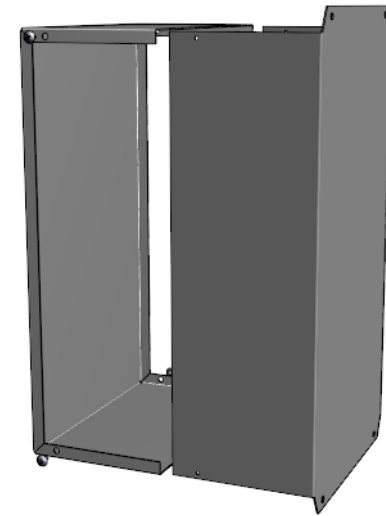
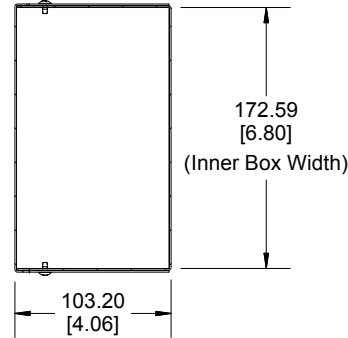

**SECTION B-B  
Side View of Assembly**

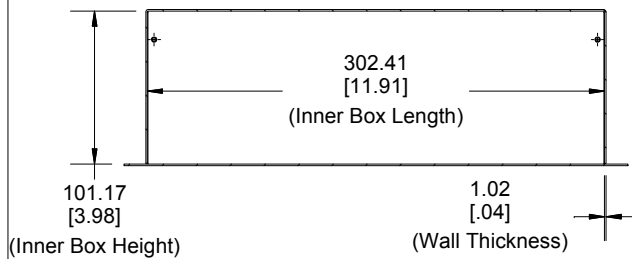

**Side View of Flanged Bottom**

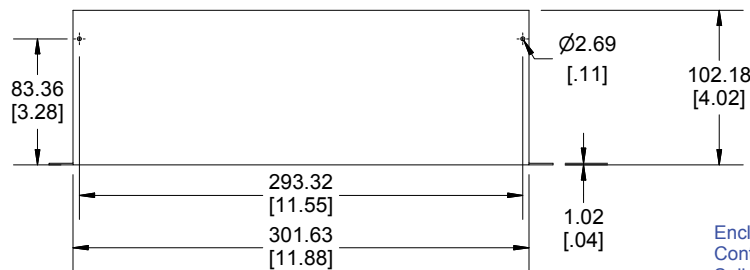

Enclosures can be Factory Modified ( Milling, Drilling, Printing etc.)  
Contact Factory [mjm@hammondmfg.com](mailto:mjm@hammondmfg.com) for quotes  
Solid models of this enclosure available in STEP or IGES.

**Side View of Cover**

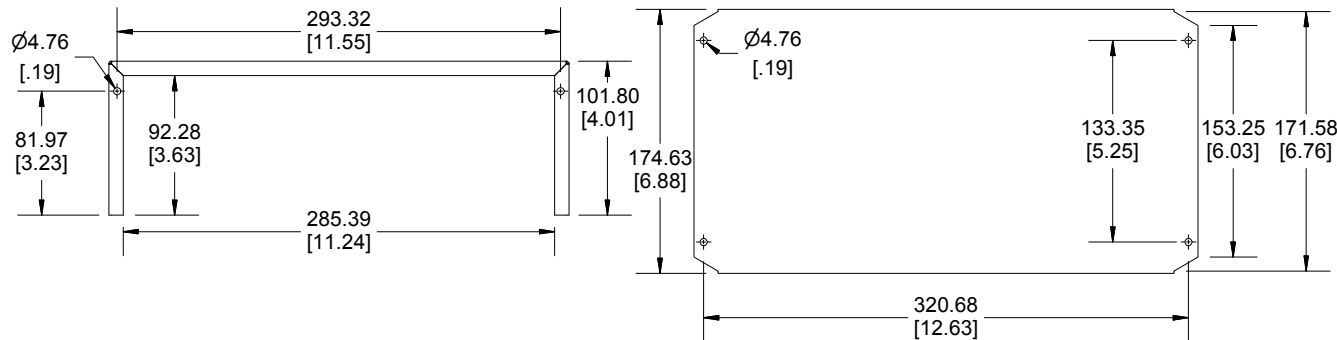

**NOTE**  
Purchased assembly includes flanged bottom, cover and 4 cover screws.  
Bottom and cover are made from 0.04" Aluminum Panels.

PART NUMBERS	
1411FBX Enclosure	
Natural Finish Enclosure	1411FBXU
Black Enclosure	1411FBXBK
ACCESSORIES	
Plated Cover Screws (Pkg 6)	1421J6
[6-32 x 1/4" Self-Tapping Screws]	
Black Cover Screws (Pkg 6)	1421J6BK
[6-32 x 1/4" Self-Tapping Screws]	

**HAMMOND  
MANUFACTURING™**

**1411FBX**

[www.hammondmfg.com](http://www.hammondmfg.com)

Dimensions:  
mm  
[inches]