

Frequency Generator for CPU, FBD, PCIe Gen 1/2 & SATA

ICS9FG108

Description

ICS9FG108 is a Frequency Timing Generator that provides 8 differential output pairs that are compliant to the Intel CK410 specification. It also provides support for PCI-Express, next generation I/O, and SATA. The part synthesizes several output frequencies from either a 14.31818 Mhz crystal or a 25 MHz crystal. The device can also be driven by a reference input clock instead of a crystal. It provides outputs with cycle-to-cycle jitter of less than 50 ps and output-to-output skew of less than 65 ps. ICS9FG108 also provides a copy of the reference clock. Frequency selection can be accomplished via strap pins or SMBus control.

Key Specifications

- Output cycle-to-cycle jitter < 50 ps
- Output to output skew < 65 ps
- +/-300 ppm frequency accuracy on output clocks
- +/-150 ppm frequency accuracy @100 MHz outputs
- 48-pin SSOP/TSSOP package
- Available in RoHS compliant packaging

Features/Benefits

- Generates common frequencies from 14.318 MHz or 25 MHz
- Crystal or reference input
- 8 - 0.7V current-mode differential output pairs
- Supports Serial-ATA at 100 MHz
- Two spread spectrum modes: 0 to -0.5 downspread and +/-0.25% centerspread
- Unused inputs may be disabled in either driven or Hi-Z state for power management.
- Programmable OE Polarity
- M/N Programming

Funtional Block Diagram

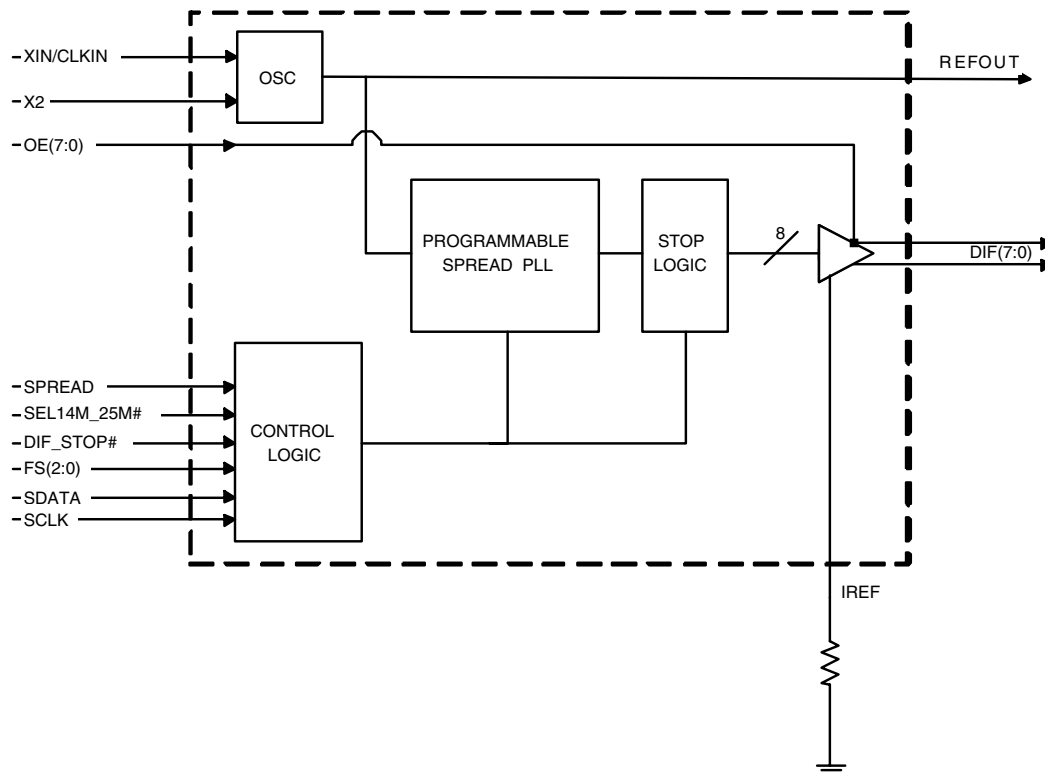

Pin Configuration

XIN/CLKIN	1	ICS9FG108	48	VDDA
X2	2		47	GNDA
VDD	3		46	IREF
GND	4		45	FS0**
REFOUT	5		44	FS1**
FS2**	6		43	OE_0**
OE_7**	7		42	DIF_0
DIF_7	8		41	DIF_0#
DIF_7#	9		40	VDD
VDD	10		39	DIF_1
DIF_6	11		38	DIF_1#
DIF_6#	12		37	OE_1*
OE_6*	13		36	VDD
VDD	14		35	GND
GND	15		34	OE_2*
OE_5*	16		33	DIF_2
DIF_5	17		32	DIF_2#
DIF_5#	18		31	VDD
VDD	19		30	DIF_3
DIF_4	20		29	DIF_3#
DIF_4#	21		28	OE_3**
OE_4**	22		27	SEL14M_25M#*
SDATA	23		26	SPREAD**
SCLK	24		25	DIF_STOP#

* indicates internal 120K pull up
** indicates internal 120K pull down

48-pin SSOP & TSSOP

Power Groups

Pin Number		Description
VDD	GND	
3	4	REFOUT, Digital Inputs, SMBus
10,14,19,31,36,40	15,35	DIF Outputs
N/A	47	IREF
48	47	Analog VDD & GND for PLL Core

Functionality Table

Frequency Select Table

SEL14M_25M# (FS3)	FS2	FS1	FS0	OUTPUT(MHz)
0	0	0	0	100.00
0	0	0	1	125.00
0	0	1	0	133.33
0	0	1	1	166.67
0	1	0	0	200.00
0	1	0	1	266.66
0	1	1	0	333.33
0	1	1	1	400.00
1	0	0	0	100.00
1	0	0	1	125.00
1	0	1	0	133.33
1	0	1	1	166.67
1	1	0	0	200.00
1	1	0	1	266.66
1	1	1	0	333.33
1	1	1	1	400.00

Pin Description

PIN #	PIN NAME	PIN TYPE	DESCRIPTION
1	XIN/CLKIN	IN	Crystal input or Reference Clock input
2	X2	OUT	Crystal output, Nominally 14.318MHz
3	VDD	PWR	Power supply, nominal 3.3V
4	GND	PWR	Ground pin.
5	REFOUT	OUT	Reference Clock output
6	**FS2	IN	Frequency select pin.
7	**OE_7	IN	Active high input for enabling output 7. 0 = tri-state outputs, 1= enable outputs
8	DIF_7	OUT	0.7V differential true clock output
9	DIF_7#	OUT	0.7V differential Complementary clock output
10	VDD	PWR	Power supply, nominal 3.3V
11	DIF_6	OUT	0.7V differential true clock output
12	DIF_6#	OUT	0.7V differential Complementary clock output
13	*OE_6	IN	Active high input for enabling output 6. 0 = tri-state outputs, 1= enable outputs
14	VDD	PWR	Power supply, nominal 3.3V
15	GND	PWR	Ground pin.
16	*OE_5	IN	Active high input for enabling output 5. 0 = tri-state outputs, 1= enable outputs
17	DIF_5	OUT	0.7V differential true clock output
18	DIF_5#	OUT	0.7V differential Complementary clock output
19	VDD	PWR	Power supply, nominal 3.3V
20	DIF_4	OUT	0.7V differential true clock output
21	DIF_4#	OUT	0.7V differential Complementary clock output
22	**OE_4	IN	Active high input for enabling output 4. 0 = tri-state outputs, 1= enable outputs
23	SDATA	I/O	Data pin for SMBus circuitry, 3.3V tolerant.
24	SCLK	IN	Clock pin of SMBus circuitry, 5V tolerant.

Note:

* indicates internal 120K pull up

** indicates internal 120K pull down

Pin Description (continued)

PIN #	PIN NAME	PIN TYPE	DESCRIPTION
25	DIF_STOP#	IN	Active low input to stop differential output clocks.
26	**SPREAD	IN	Asynchronous, active high input to enable spread spectrum functionality.
27	*SEL14M_25M#	IN	Select 14.31818 MHz or 25 Mhz input frequency. 1 = 14.31818 MHz, 0 = 25 MHz
28	**OE_3	IN	Active high input for enabling output 3. 0 = tri-state outputs, 1= enable outputs
29	DIF_3#	OUT	0.7V differential Complementary clock output
30	DIF_3	OUT	0.7V differential true clock output
31	VDD	PWR	Power supply, nominal 3.3V
32	DIF_2#	OUT	0.7V differential Complementary clock output
33	DIF_2	OUT	0.7V differential true clock output
34	*OE_2	IN	Active high input for enabling output 2. 0 = tri-state outputs, 1= enable outputs
35	GND	PWR	Ground pin.
36	VDD	PWR	Power supply, nominal 3.3V
37	*OE_1	IN	Active high input for enabling output 1. 0 = tri-state outputs, 1= enable outputs
38	DIF_1#	OUT	0.7V differential Complementary clock output
39	DIF_1	OUT	0.7V differential true clock output
40	VDD	PWR	Power supply, nominal 3.3V
41	DIF_0#	OUT	0.7V differential Complementary clock output
42	DIF_0	OUT	0.7V differential true clock output
43	**OE_0	IN	Active high input for enabling output 0. 0 = tri-state outputs, 1= enable outputs
44	**FS1	I/O	Frequency select pin.
45	**FS0	IN	Frequency select pin.
46	IREF	OUT	This pin establishes the reference current for the differential current-mode output pairs. This pin requires a fixed precision resistor tied to ground in order to establish the appropriate current. 475 ohms is the standard value.
47	GNDA	PWR	Ground pin for the PLL core.
48	VDDA	PWR	3.3V power for the PLL core.

Note:

* indicates internal 120K pull up

** indicates internal 120K pull down

Absolute Max (Commercial)

Symbol	Parameter	Min	Max	Units
VDD_A	3.3V Core Supply Voltage		V _{DD} + 0.5V	V
VDD_In	3.3V Logic Input Supply Voltage	GND - 0.5	V _{DD} + 0.5V	V
Ts	Storage Temperature	-65	150	°C
Tambient	Ambient Operating Temp	0	70	°C
Tcase	Case Temperature		115	°C
ESD prot	Input ESD protection human body model	2000		V

Electrical Characteristics - Input/Supply/Common Output Parameters (Commercial)

T_A = 0 - 70°C; Supply Voltage V_{DD} = 3.3 V +/-5%

PARAMETER	SYMBOL	CONDITIONS	MIN	TYP	MAX	UNITS	NOTES
Input High Voltage	V _{IH}	3.3 V +/-5%	2		V _{DD} + 0.3	V	
Input Low Voltage	V _{IL}	3.3 V +/-5%	V _{SS} - 0.3		0.8	V	
Input High Current	I _{IH}	V _{IN} = V _{DD}	-5		5	uA	
Input Low Current	I _{IL1}	V _{IN} = 0 V; Inputs with no pull-up resistors	-5			uA	
	I _{IL2}	V _{IN} = 0 V; Inputs with pull-up resistors	-200			uA	
Operating Supply Current	I _{DD3.3OP}	Full Active, C _L = Full load; f = 400 MHz		215	250	mA	1
		Full Active, C _L = Full load; f = 100 MHz		180	200	mA	1
	I _{DD3.3STOP}	All outputs stopped driven		180	200	mA	1
All outputs stopped Hi-Z			51	60	mA	1	
Input Frequency ³	F _i	V _{DD} = 3.3 V	14		25	MHz	3
Pin Inductance ¹	L _{pin}				7	nH	1
Input/Output Capacitance ¹	C _{IN}	Logic Inputs	1.5		5	pF	1
	C _{OUT}	Output pin capacitance			6	pF	1
Clk Stabilization ^{1,2}	T _{STAB}	From V _{DD} Power-Up and after input clock stabilization to 1st clock			1.8	ms	1,2
Modulation Frequency	f _{MOD}	Triangular Modulation	30		33	kHz	1
DIF output enable	t _{DIFOE}	DIF output enable after DIF_Stop# de-assertion			15	ns	1
Input Rise and Fall times	t _R /t _F	20% to 80% of VDD			5	ns	1

¹Guaranteed by design and characterization, not 100% tested in production.

²See timing diagrams for timing requirements.

³ Input frequency should be measured at the REFOUT pin and tuned to ideal 14.31818MHz or 25 MHz to meet

Electrical Characteristics - DIF 0.7V Current Mode Differential Pair (Commercial)

$T_A = 0 - 70^\circ\text{C}$; $V_{DD} = 3.3\text{ V} \pm 5\%$; $C_L = 2\text{pF}$, $R_S = 33.2\Omega$, $R_P = 49.9\Omega$, $I_{REF} = 475\Omega$

PARAMETER	SYMBOL	CONDITIONS	MIN	TYP	MAX	UNITS	NOTES
Current Source Output Impedance	Z_o^1	$V_O = V_x$	3000			Ω	1
Voltage High	VHigh	Statistical measurement on single ended signal using oscilloscope math function.	660		850	mV	1
Voltage Low	VLow		-150		150		1
Max Voltage	Vovs	Measurement on single ended signal using absolute value.			1150	mV	1
Min Voltage	Vuds		-300				1
Crossing Voltage (abs)	Vcross(abs)		250		550	mV	1
Crossing Voltage (var)	d-Vcross	Crossing variation over all edges			140	mV	1
Long Accuracy	ppm	see Tperiod min-max values	-300		300	ppm	1,2,5
Average period	Tperiod	400MHz nominal	2.4993		2.5008	ns	2
		400MHz spread	2.4993		2.5133	ns	2,3
		333.33MHz nominal	2.9991		3.0009	ns	2
		333.33MHz spread	2.9991		3.016	ns	2,3
		266.66MHz nominal	3.7489		3.7511	ns	2
		266.66MHz spread	3.7489		3.77	ns	2,3
		200MHz nominal	4.9985		5.0015	ns	2
		200MHz spread	4.9985		5.0266	ns	2,3
		166.66MHz nominal	5.9982		6.0018	ns	2
		166.66MHz spread	5.9982		6.0320	ns	2,3
		133.33MHz nominal	7.4978		7.5023	ns	2
		133.33MHz spread	7.4978		5.4000	ns	2,3
		100.00MHz nominal	9.9970		10.0030	ns	2
		100.00MHz spread	9.9970		10.0533	ns	2,3
Absolute min period	T _{absmin}	400MHz nominal/spread	2.4143			ns	1,2
		333.33MHz nominal/spread	2.9141			ns	1,2
		266.66MHz nominal/spread	3.6639			ns	1,2
		200MHz nominal/spread	4.8735			ns	1,2
		166.66MHz nominal/spread	5.8732			ns	1,2
		133.33MHz nominal/spread	7.3728			ns	1,2
		100.00MHz nominal/spread	9.8720			ns	1,2
Rise Time	t_r	$V_{OL} = 0.175\text{V}$, $V_{OH} = 0.525\text{V}$	175		700	ps	1
Fall Time	t_f	$V_{OH} = 0.525\text{V}$, $V_{OL} = 0.175\text{V}$	175		700	ps	1
Rise Time Variation	d- t_r				125	ps	1
Fall Time Variation	d- t_f				125	ps	1
Duty Cycle	d_{t3}	Measured Differentially	45		55	%	1
Skew, output to output	t_{sk3}	$V_T = 50\%$			65	ps	1
Jitter, PCI-e SRC phase	$t_{j\text{PCI-ephase}14}$	22MHz/1.5MHz/1.5MHz/10ns, 14.31818 MHz REF Clock			42	ps	4
Jitter, PCI-e SRC phase	$t_{j\text{PCI-ephase}25}$	22MHz/1.5MHz/1.5MHz/10ns, 25 MHz REF Clock			39	ps	4
Jitter, Cycle to cycle	$t_{j\text{cyc-cyc}}$	Measurement from differential waveform		40	50	ps	1

¹Guaranteed by design and characterization, not 100% tested in production.

²All Long Term Accuracy and Clock Period specifications are guaranteed assuming that REFOUT is at 14.31818MHz or 25 MHz

³ Figures are for down spread.

⁴ This figure is the peak-to-peak phase jitter as defined by PCI-SIG for a PCI Express reference clock. Please visit <http://www.pcisig.com> for additional details

⁵ +/- 150 ppm for 100 MHz outputs

Electrical Characteristics - REF-14.318/25 MHz (Commercial)

T_A = 0 - 70°C; V_{DD} = 3.3 V +/-5%; C_L = 10-20 pF (unless otherwise specified)

PARAMETER	SYMBOL	CONDITIONS	MIN	TYP	MAX	UNITS	Notes
Long Accuracy	ppm	see T _{period} min-max values	-300	0	300	ppm	1
Clock period	T _{period}	14.318MHz output nominal	69.8270	69.8413	69.8550	ns	1,2
Clock period	T _{period}	25.000MHz output nominal	39.9880	40.0000	40.0120	ns	1,2
Output High Voltage	V _{OH}	I _{OH} = -1 mA	2.4			V	1
Output Low Voltage	V _{OL}	I _{OL} = 1 mA			0.4	V	1
Output High Current	I _{OH}	V _{OH} @MIN = 1.0 V, V _{OH} @MAX = 3.135 V	-29		-23	mA	1
Output Low Current	I _{OL}	V _{OL} @MIN = 1.95 V, V _{OL} @MAX = 0.4 V	29		27	mA	1
Rise Time	t _{r1}	V _{OL} = 0.4 V, V _{OH} = 2.4 V	1	1.6	2	ns	1
Fall Time	t _{f1}	V _{OH} = 2.4 V, V _{OL} = 0.4 V	1	1.6	2	ns	1
Duty Cycle	d _{t1}	V _T = 1.5 V	45		55	%	1
Jitter	t _{jyc-cyc}	V _T = 1.5 V		150	350	ps	1

¹Guaranteed by design and characterization, not 100% tested in production.

²All Long Term Accuracy and Clock Period specifications are guaranteed assuming that REFOUT is at 14.31818 or 25.00 MHz

Electrical Characteristics - Phase Jitter (Commercial)

T_A = 0 - 70°C; V_{DD} = 3.3 V +/-5%; C_L = 10-20 pF (unless otherwise specified)

PARAMETER	SYMBOL	CONDITIONS	MIN	TYP.	MAX	UNITS	NOTES
Jitter, Phase	t _{jphPCle1}	PCIe Gen 1 REFCLK phase jitter (including PLL BW 8 - 16 MHz, ζ = 0.54, T _d =10 ns, F _{trk} =1.5 MHz)		36/41	86	ps	1,2,3,4
	t _{jphPCle2Lo}	PCIe Gen 2 REFCLK phase jitter (including PLL BW 8 - 16 MHz, ζ = 0.54, T _d =12 ns) Lo-band content (10kHz to 1.5MHz)		0.7/0.8	3	ps rms	1,2,4,5
	t _{jphPCle2Hi}	PCIe Gen 2 REFCLK phase jitter (including PLL BW 8 - 16 MHz, ζ = 0.54, T _d =12 ns) Hi-band content (1.5MHz to Nyquist)		1.8/1.9	3.1	ps rms	1,2,4,5
	t _{jphFBD1_3.2G}	FBD REFCLK phase jitter (including PLL BW 11 - 33 MHz, ζ = 0.54, T _d =12 ns F _{trl} =0.2MHz)		1.7/1.8	3	ps (RMS)	1,2,4,5
	t _{jphFBD1_4.8G}	FBD REFCLK phase jitter (including PLL BW 11 - 33 MHz, ζ = 0.54, T _d =12 ns F _{trl} =0.2MHz)		1.3/1.4	2.5	ps (RMS)	1,2,4,5

Notes on Phase Jitter:

¹ See <http://www.pcisig.com> for complete specs. Guaranteed by design and characterization, not tested in production.

² Device driven 14.318MHz and 25MHz crystal

³ Sample size of at least 100K cycles. This figures extrapolates to 108ps pk-pk @ 1M cycles for a BER of 1⁻¹²

⁴ First number is with Spread Spectrum off, second number is with Spread Spectrum off.

⁵ Only Applies to Rev D and higher devices.

Absolute Max (Industrial)

Symbol	Parameter	Min	Max	Units
VDD_A	3.3V Core Supply Voltage		V _{DD} + 0.5V	V
VDD_In	3.3V Logic Input Supply Voltage	GND - 0.5	V _{DD} + 0.5V	V
Ts	Storage Temperature	-65	150	°C
Tambient	Ambient Operating Temp	-40	85	°C
Tcase	Case Temperature		115	°C
ESD prot	Input ESD protection human body model	2000		V

Electrical Characteristics - Input/Supply/Common Output Parameters (Industrial)

T_A = -40 - 85°C; Supply Voltage V_{DD} = 3.3 V +/-5%

PARAMETER	SYMBOL	CONDITIONS	MIN	TYP	MAX	UNITS	NOTES
Input High Voltage	V _{IH}	3.3 V +/-5%	2		V _{DD} + 0.3	V	
Input Low Voltage	V _{IL}	3.3 V +/-5%	V _{SS} - 0.3		0.8	V	
Input High Current	I _{IH}	V _{IN} = V _{DD}	-5		5	uA	
Input Low Current	I _{IL1}	V _{IN} = 0 V; Inputs with no pull-up resistors	-5			uA	
	I _{IL2}	V _{IN} = 0 V; Inputs with pull-up resistors	-200			uA	
Operating Supply Current	I _{DD3.3OP}	Full Active, C _L = Full load; f = 400 MHz		230	250	mA	1
		Full Active, C _L = Full load; f = 100 MHz		190	200	mA	1
	I _{DD3.3STOP}	All outputs stopped driven		185	200	mA	1
		All outputs stopped Hi-Z		55	60	mA	1
Input Frequency ³	F _i	V _{DD} = 3.3 V	14		25	MHz	3
Pin Inductance ¹	L _{pin}				7	nH	1
Input/Output Capacitance ¹	C _{IN}	Logic Inputs	1.5		5	pF	1
	C _{OUT}	Output pin capacitance			6	pF	1
Clk Stabilization ^{1,2}	T _{STAB}	From V _{DD} Power-Up and after input clock stabilization to 1st clock			1.8	ms	1,2
Modulation Frequency	f _{MOD}	Triangular Modulation	30		33	kHz	1
DIF output enable	t _{DIFOE}	DIF output enable after DIF_Stop# de-assertion			15	ns	1
Input Rise and Fall times	t _r /t _f	20% to 80% of VDD			5	ns	1

¹Guaranteed by design and characterization, not 100% tested in production.

²See timing diagrams for timing requirements.

³ Input frequency should be measured at the REFOUT pin and tuned to ideal 14.31818MHz or 25 MHz to meet ppm frequency accuracy on PLL outputs.

Electrical Characteristics - DIF 0.7V Current Mode Differential Pair

T_A = -40 - 85°C; V_{DD} = 3.3 V +/-5%; C_L =2pF, R_S=33.2Ω, R_P=49.9Ω, I_{REF} = 475Ω

PARAMETER	SYMBOL	CONDITIONS	MIN	TYP	MAX	UNITS	NOTES
Current Source Output Impedance	Zo ¹	V _O = V _x	3000			Ω	1
Voltage High	VHigh	Statistical measurement on single ended signal using oscilloscope math function.	660		850	mV	1
Voltage Low	VLow		-150		150		1
Max Voltage	Vovs	Measurement on single ended signal using absolute value.			1150	mV	1
Min Voltage	Vuds		-300				1
Crossing Voltage (abs)	Vcross(abs)		250		550	mV	1
Crossing Voltage (var)	d-Vcross	Crossing variation over all edges			140	mV	1
Long Accuracy	ppm	see Tperiod min-max values	-300		300	ppm	1,2,5
Average period	Tperiod	400MHz nominal	2.4993		2.5008	ns	2
		400MHz spread	2.4993		2.5133	ns	2,3
		333.33MHz nominal	2.9991		3.0009	ns	2
		333.33MHz spread	2.9991		3.016	ns	2,3
		266.66MHz nominal	3.7489		3.7511	ns	2
		266.66MHz spread	3.7489		3.77	ns	2,3
		200MHz nominal	4.9985		5.0015	ns	2
		200MHz spread	4.9985		5.0266	ns	2,3
		166.66MHz nominal	5.9982		6.0018	ns	2
		166.66MHz spread	5.9982		6.0320	ns	2,3
		133.33MHz nominal	7.4978		7.5023	ns	2
		133.33MHz spread	7.4978		5.4000	ns	2,3
Absolute min period	T _{absmin}	400MHz nominal/spread	2.4143			ns	1,2
		333.33MHz nominal/spread	2.9141			ns	1,2
		266.66MHz nominal/spread	3.6639			ns	1,2
		200MHz nominal/spread	4.8735			ns	1,2
		166.66MHz nominal/spread	5.8732			ns	1,2
		133.33MHz nominal/spread	7.3728			ns	1,2
		100.00MHz nominal/spread	9.8720			ns	1,2
Rise Time	t _r	V _{OL} = 0.175V, V _{OH} = 0.525V	175		700	ps	1
Fall Time	t _f	V _{OH} = 0.525V V _{OL} = 0.175V	175		700	ps	1
Rise Time Variation	d-t _r				125	ps	1
Fall Time Variation	d-t _f				125	ps	1
Duty Cycle	d _{t3}	Measured Differentially	45		55	%	1
Skew, output to output	t _{sk3}	V _T = 50%			65	ps	1
Jitter, PCI-e SRC phase	t _{jPCI-ephase14}	22MHz/1.5MHz/1.5MHz/10ns, 14.31818 MHz REF Clock			42	ps	4
Jitter, PCI-e SRC phase	t _{jPCI-ephase25}	22MHz/1.5MHz/1.5MHz/10ns, 25 MHz REF Clock			39	ps	4
Jitter, Cycle to cycle	t _{jCyc-cyc}	Measurement from differential waveform		40	50	ps	1

¹Guaranteed by design and characterization, not 100% tested in production.

² All Long Term Accuracy and Clock Period specifications are guaranteed assuming that REFOUT is at 14.31818MHz or 25 MHz

³ Figures are for down spread.

⁴ This figure is the peak-to-peak phase jitter as defined by PCI-SIG for a PCI Express reference clock. Please visit <http://www.pcisig.com> for additional details

⁵ +/- 150 ppm for 100 MHz outputs

Electrical Characteristics - REF-14.318/25 MHz (Industrial)

T_A = -40 - 85°C; V_{DD} = 3.3 V +/-5%; C_L = 10-20 pF (unless otherwise specified)

PARAMETER	SYMBOL	CONDITIONS	MIN	TYP	MAX	UNITS	Notes
Long Accuracy	ppm	see Tperiod min-max values	-300	0	300	ppm	1
Clock period	T _{period}	14.318MHz output nominal	69.8270	69.8413	69.8550	ns	1,2
Clock period	T _{period}	25.000MHz output nominal	39.9880	40.0000	40.0120	ns	1,2
Output High Voltage	V _{OH}	I _{OH} = -1 mA	2.4			V	1
Output Low Voltage	V _{OL}	I _{OL} = 1 mA			0.4	V	1
Output High Current	I _{OH}	V _{OH} @MIN = 1.0 V, V _{OH} @MAX = 3.135 V	-29		-23	mA	1
Output Low Current	I _{OL}	V _{OL} @MIN = 1.95 V, V _{OL} @MAX = 0.4 V	29		27	mA	1
Rise Time	t _{r1}	V _{OL} = 0.4 V, V _{OH} = 2.4 V	1	1.6	2	ns	1
Fall Time	t _{f1}	V _{OH} = 2.4 V, V _{OL} = 0.4 V	1	1.6	2	ns	1
Duty Cycle	d _{t1}	V _T = 1.5 V	45		55	%	1
Jitter	t _{jyc-cyc}	V _T = 1.5 V		150	350	ps	1

¹Guaranteed by design and characterization, not 100% tested in production.

² All Long Term Accuracy and Clock Period specifications are guaranteed assuming that REFOUT is at 14.31818 or 25.00 MHz

Electrical Characteristics - Phase Jitter (Industrial)

T_A = -40 - 85°C; V_{DD} = 3.3 V +/-5%; C_L = 10-20 pF (unless otherwise specified)

PARAMETER	SYMBOL	CONDITIONS	MIN	TYP.	MAX	UNITS	NOTES
Jitter, Phase	t _{jphPCle1}	PCIe Gen 1 REFCLK phase jitter (including PLL BW 8 - 16 MHz, ζ = 0.54, Td=10 ns, Ftrk=1.5 MHz)		25/31	86	ps	1,2,3,4
	t _{jphPCle2Lo}	PCIe Gen 2 REFCLK phase jitter (including PLL BW 8 - 16 MHz, ζ = 0.54, Td=12 ns) Lo-band content (10kHz to 1.5MHz)		0.7/0.8	3	ps rms	1,2,4,5
	t _{jphPCle2Hi}	PCIe Gen 2 REFCLK phase jitter (including PLL BW 8 - 16 MHz, ζ = 0.54, Td=12 ns) Hi-band content (1.5MHz to Nyquist)		1.7/2.0	3.1	ps rms	1,2,4,5
	t _{jphFBD1_3.2G}	FBD REFCLK phase jitter (including PLL BW 11 - 33 MHz, ζ = 0.54, Td=12 ns Ftrl=0.2MHz)		1.7/1.9	3	ps (RMS)	1,2,4,5
	t _{jphFBD1_4.8G}	FBD REFCLK phase jitter (including PLL BW 11 - 33 MHz, ζ = 0.54, Td=12 ns Ftrl=0.2MHz)		1.3/1.6	2.5	ps (RMS)	1,2,4,5

Notes on Phase Jitter:

¹ See <http://www.pcisig.com> for complete specs. Guaranteed by design and characterization, not tested in production.

² Device driven 14.318MHz and 25MHz crystal

³ Sample size of at least 100K cycles. This figures extrapolates to 108ps pk-pk @ 1M cycles for a BER of 1⁻¹²

⁴ First number is with Spread Spectrum off, second number is with Spread Spectrum off.

⁵ Only Applies to Rev D and higher devices.

General SMBus serial interface information for the ICS9FG108

How to Write:

- Controller (host) sends a start bit.
- Controller (host) sends the write address $DC_{(h)}$
- ICS clock will **acknowledge**
- Controller (host) sends the beginning byte location = N
- ICS clock will **acknowledge**
- Controller (host) sends the data byte count = X
- ICS clock will **acknowledge**
- Controller (host) starts sending **Byte N through Byte N + X - 1**
- ICS clock will **acknowledge** each byte **one at a time**
- Controller (host) sends a Stop bit

How to Read:

- Controller (host) will send start bit.
- Controller (host) sends the write address $DC_{(h)}$
- ICS clock will **acknowledge**
- Controller (host) sends the beginning byte location = N
- ICS clock will **acknowledge**
- Controller (host) will send a separate start bit.
- Controller (host) sends the read address $DD_{(h)}$
- ICS clock will **acknowledge**
- ICS clock will send the data byte count = X
- ICS clock sends **Byte N + X - 1**
- ICS clock sends **Byte 0 through byte X (if $X_{(h)}$ was written to byte 8).**
- Controller (host) will need to acknowledge each byte
- Controller (host) will send a not acknowledge bit
- Controller (host) will send a stop bit

Index Block Write Operation		
Controller (Host)		ICS (Slave/Receiver)
T	starT bit	
Slave Address $DC_{(h)}$		
WR	WRite	
		ACK
Beginning Byte = N		
		ACK
Data Byte Count = X		
		ACK
Beginning Byte N	X Byte	ACK
◊		◊
◊		◊
◊		◊
Byte N + X - 1		◊
		ACK
P	stoP bit	

Index Block Read Operation		
Controller (Host)		ICS (Slave/Receiver)
T	starT bit	
Slave Address $DC_{(h)}$		
WR	WRite	
		ACK
Beginning Byte = N		
		ACK
RT	Repeat starT	
Slave Address $DD_{(h)}$		
RD	ReaD	
		ACK
		Data Byte Count = X
ACK		
ACK		Beginning Byte N
◊		◊
◊		◊
◊		◊
		Byte N + X - 1
N	Not acknowledge	
P	stoP bit	

SMBus Table: Device Control Register, READ/WRITE ADDRESS (DC/DD)

Byte 0	Pin #	Name	Control Function	Type	0	1	Default
Bit 7	27		FS3 ¹	RW	See Frequency Selection Table, Page 1		Pin 27
Bit 6	5		FS2 ¹	RW			Pin 5
Bit 5	44		FS1 ¹	RW			Pin 44
Bit 4	7		FS0 ¹	RW			Pin 7
Bit 3	26		Spread Enable ¹	RW	Off	On	Pin 26
Bit 2	-	Enable Software Control of Frequency, Spread Enable (Spread Type always		RW	Hardware Select	Software Select	0
Bit 1	-	DIF_STOP# drive mode		RW	Driven	Hi-Z	0
Bit 0	-	Spread Type		RW	Down	Center	0

Notes:

1. These bits reflect the state of the corresponding pins at power up, but may be written to if Byte 0, bit 2 is set to '1'. FS3 is the SEL14M_25M# pin.

SMBus Table: Output Enable Register

Byte 1	Pin #	Name	Control Function	Type	0	1	Default
Bit 7	-	DIF_7 EN	Output Enable	RW	Disable	Enable	1
Bit 6	-	DIF_6 EN	Output Enable	RW	Disable	Enable	1
Bit 5	-	DIF_5 EN	Output Enable	RW	Disable	Enable	1
Bit 4	-	DIF_4 EN	Output Enable	RW	Disable	Enable	1
Bit 3	-	DIF_3 EN	Output Enable	RW	Disable	Enable	1
Bit 2	-	DIF_2 EN	Output Enable	RW	Disable	Enable	1
Bit 1	-	DIF_1 EN	Output Enable	RW	Disable	Enable	1
Bit 0	-	DIF_0 EN	Output Enable	RW	Disable	Enable	1

Note: Byte 1 sets outputs active or inactive, not the conditions set by the OE inputs.

SMBus Table: Output Stop Mode Register

Byte 2	Pin #	Name	Control Function	Type	0	1	Default
Bit 7	-	DIF_7 STOP EN	Free Run/ Stop Enable	RW	Free-run	Stop-able	0
Bit 6	-	DIF_6 STOP EN	Free Run/ Stop Enable	RW	Free-run	Stop-able	0
Bit 5	-	DIF_5 STOP EN	Free Run/ Stop Enable	RW	Free-run	Stop-able	0
Bit 4	-	DIF_4 STOP EN	Free Run/ Stop Enable	RW	Free-run	Stop-able	0
Bit 3	-	DIF_3 STOP EN	Free Run/ Stop Enable	RW	Free-run	Stop-able	0
Bit 2	-	DIF_2 STOP EN	Free Run/ Stop Enable	RW	Free-run	Stop-able	0
Bit 1	-	DIF_1 STOP EN	Free Run/ Stop Enable	RW	Free-run	Stop-able	0
Bit 0	-	DIF_0 STOP EN	Free Run/ Stop Enable	RW	Free-run	Stop-able	0

SMBus Table: Frequency Select Readback Register

Byte 3	Pin #	Name	Control Function	Type	0	1	Default
Bit 7	27	SEL14M_25M# ¹ (FS3)	State of pin 27	R	See Frequency Selection Table, Page 1		Pin 27
Bit 6	6	FS2 ¹	State of pin 6	R			Pin 6
Bit 5	44	FS1 ¹	State of pin 44	R			Pin 44
Bit 4	45	FS0 ¹	State of pin 45	R			Pin 45
Bit 3	26	SPREAD ¹	State of pin 26	R	Off	On	Pin 26
Bit 2			Reserved	R	Reserved		X
Bit 1			Reserved	R	Reserved		X
Bit 0			Reserved	R	Reserved		X

Notes:

1. These bits reflect the state of the corresponding pins, regardless of whether software programming is enabled or not.

SMBus Table: Vendor & Revision ID Register

Byte 4	Pin #	Name	Control Function	Type	0	1	Default
Bit 7	-	RID3	REVISION ID	R	-	-	X
Bit 6	-	RID2		R	-	-	X
Bit 5	-	RID1		R	-	-	X
Bit 4	-	RID0		R	-	-	X
Bit 3	-	VID3	VENDOR ID	R	-	-	0
Bit 2	-	VID2		R	-	-	0
Bit 1	-	VID1		R	-	-	0
Bit 0	-	VID0		R	-	-	1

SMBus Table: DEVICE ID

Byte 5	Pin #	Name	Control Function	Type	0	1	Default
Bit 7	-	DEVID7	Device ID = 08 hex	R	Reserved		0
Bit 6	-	DEVID6		R	Reserved		0
Bit 5	-	DEVID5		R	Reserved		0
Bit 4	-	DEVID4		R	Reserved		0
Bit 3	-	DEVID3		R	Reserved		1
Bit 2	-	DEVID2		R	Reserved		0
Bit 1	-	DEVID1		R	Reserved		0
Bit 0	-	DEVID0		R	Reserved		0

SMBus Table: Byte Count Register

Byte 6	Pin #	Name	Control Function	Type	0	1	Default
Bit 7	-	BC7	Writing to this register will configure how many bytes will be read back, default is 07 = 7 bytes.	RW	-	-	0
Bit 6	-	BC6		RW	-	-	0
Bit 5	-	BC5		RW	-	-	0
Bit 4	-	BC4		RW	-	-	0
Bit 3	-	BC3		RW	-	-	0
Bit 2	-	BC2		RW	-	-	1
Bit 1	-	BC1		RW	-	-	1
Bit 0	-	BC0		RW	-	-	1

SMBus Table: Reserved Register

Byte 7	Pin #	Name	Control Function	Type	0	1	Default
Bit 7			Reserved				X
Bit 6			Reserved				X
Bit 5			Reserved				X
Bit 4			Reserved				X
Bit 3			Reserved				X
Bit 2			Reserved				X
Bit 1			Reserved				X
Bit 0			Reserved				X

SMBus Table: Reserved Register

Byte 8	Pin #	Name	Control Function	Type	0	1	Default
Bit 7			Reserved				X
Bit 6			Reserved				X
Bit 5			Reserved				X
Bit 4			Reserved				X
Bit 3			Reserved				X
Bit 2			Reserved				X
Bit 1			Reserved				X
Bit 0			Reserved				X

SMBus Table: M/N Programming Enable

Byte 9	Pin #	Name	Control Function	Type	0	1	Default
Bit 7	-	M/N_EN	PLL M/N Programming Enable	RW	Disable	Enable	0
Bit 6	-	OE_Polarity	Select Polarity of OE inputs	RW	OE#	OE	1
Bit 5	5	REFOUT_En	Enables/Disables REF	RW	Disable	Enable	1
Bit 4			Reserved				0
Bit 3			Reserved				0
Bit 2			Reserved				0
Bit 1			Reserved				0
Bit 0			Reserved				0

SMBus Table: PLL Frequency Control Register

Byte 10	Pin #	Name	Control Function	Type	0	1	Default
Bit 7	-	PLL N Div8	N Divider Prog bit 8	RW	The decimal representation of M and N Divider in Byte 11 and 12 will configure the PLL VCO frequency. Default at power up = latch-in or Byte 0 Rom table. VCO Frequency = $f_{XTAL} \times \frac{[NDiv(9:0)+8]}{[MDiv(5:0)+2]}$		X
Bit 6	-	PLL N Div9	N Divider Prog bit 9	RW			X
Bit 5	-	PLL M Div5	M Divider Programming bit (5:0)	RW			X
Bit 4	-	PLL M Div4		RW			X
Bit 3	-	PLL M Div3		RW			X
Bit 2	-	PLL M Div2		RW			X
Bit 1	-	PLL M Div1		RW			X
Bit 0	-	PLL M Div0		RW			X

SMBus Table: PLL Frequency Control Register

Byte 11	Pin #	Name	Control Function	Type	0	1	Default
Bit 7	-	PLL N Div7	N Divider Programming Byte11 bit(7:0) and Byte10 bit(7:6)	RW	The decimal representation of M and N Divider in Byte 11 and 12 will configure the PLL VCO frequency. Default at power up = latch-in or Byte 0 Rom table. VCO Frequency = fXTAL x [NDiv(9:0)+8] /[MDiv(5:0)+2]		X
Bit 6	-	PLL N Div6		RW		X	
Bit 5	-	PLL N Div5		RW		X	
Bit 4	-	PLL N Div4		RW		X	
Bit 3	-	PLL N Div3		RW		X	
Bit 2	-	PLL N Div2		RW		X	
Bit 1	-	PLL N Div1		RW		X	
Bit 0	-	PLL N Div0		RW		X	

SMBus Table: PLL Spread Spectrum Control Register

Byte 12	Pin #	Name	Control Function	Type	0	1	Default
Bit 7	-	PLL SSP7	Spread Spectrum Programming bit(7:0)	RW	These Spread Spectrum bits in Byte 13 and 14 will program the spread percentage of PLL		X
Bit 6	-	PLL SSP6		RW		X	
Bit 5	-	PLL SSP5		RW		X	
Bit 4	-	PLL SSP4		RW		X	
Bit 3	-	PLL SSP3		RW		X	
Bit 2	-	PLL SSP2		RW		X	
Bit 1	-	PLL SSP1		RW		X	
Bit 0	-	PLL SSP0		RW		X	

SMBus Table: PLL Spread Spectrum Control Register

Byte 13	Pin #	Name	Control Function	Type	0	1	Default
Bit 7	-		Reserved				0
Bit 6	-	PLL SSP14	Spread Spectrum Programming bit(14:8)	RW	These Spread Spectrum bits in Byte 13 and 14 will program the spread percentage of PLL		X
Bit 5	-	PLL SSP13		RW		X	
Bit 4	-	PLL SSP12		RW		X	
Bit 3	-	PLL SSP11		RW		X	
Bit 2	-	PLL SSP10		RW		X	
Bit 1	-	PLL SSP9		RW		X	
Bit 0	-	PLL SSP8		RW		X	

SMBus Table: Reserved Test Register

Byte 14	Pin #	Name	Control Function	Type	0	1	Default
Bit 7	-	Reserved Test Register. Do not write to this register, erratic device operation may occur.					1
Bit 6	-						0
Bit 5	-						0
Bit 4	-						0
Bit 3	-						0
Bit 2	-						0
Bit 1	-						0
Bit 0	-						0

DIF_STOP# - Assertion (transition from '1' to '0')

Asserting DIF_STOP# pin stops all DIF outputs that are set to be stoppable after their next transition. When the SMBus DIF_STOP tri-state bit corresponding to the DIF output of interest is programmed to a '0', DIF output will stop DIF_True = HIGH and DIF_Complement = LOW. When the SMBus DIF_STOP tri-state bit corresponding to the DIF output of interest is programmed to a '1', DIF outputs will be tri-stated.

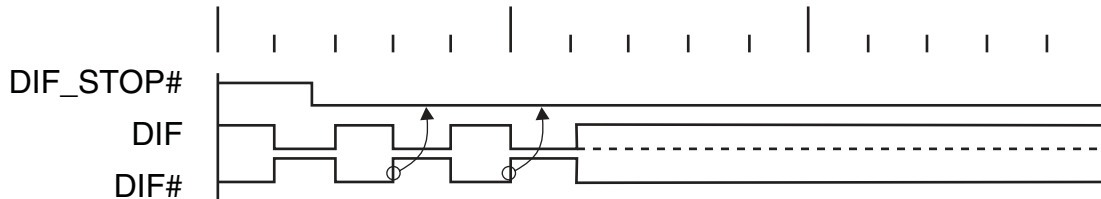

DIF_STOP# - De-assertion (transition from '0' to '1')

With the de-assertion of DIF_STOP# all stopped DIF outputs will resume without a glitch. The maximum latency from the de-assertion to active outputs is 2 - 6 DIF clock periods. If the control register tristate bit corresponding to the output of interest is programmed to '1', then the stopped DIF outputs will be driven High within 15nS of DIF_Stop# de-assertion to a voltage greater than 200mV.

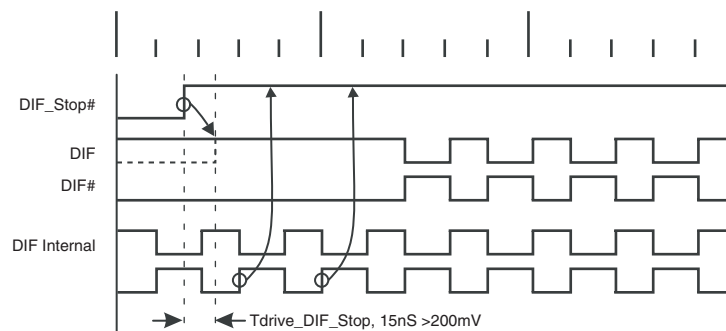

DIF Reference Clock			
Common Recommendations for Differential Routing	Dimension or Value	Unit	Figure
L1 length, Route as non-coupled 50 ohm trace.	0.5 max	inch	1
L2 length, Route as non-coupled 50 ohm trace.	0.2 max	inch	1
L3 length, Route as non-coupled 50 ohm trace.	0.2 max	inch	1
Rs	33	ohm	1
Rt	49.9	ohm	1

Down Device Differential Routing	Dimension or Value	Unit	Figure
L4 length, Route as coupled microstrip 100 ohm differential trace.	2 min to 16 max	inch	1
L4 length, Route as coupled stripline 100 ohm differential trace.	1.8 min to 14.4 max	inch	1

Differential Routing to PCI Express Connector	Dimension or Value	Unit	Figure
L4 length, Route as coupled microstrip 100 ohm differential trace.	0.25 to 14 max	inch	2
L4 length, Route as coupled stripline 100 ohm differential trace.	0.225 min to 12.6 max	inch	2

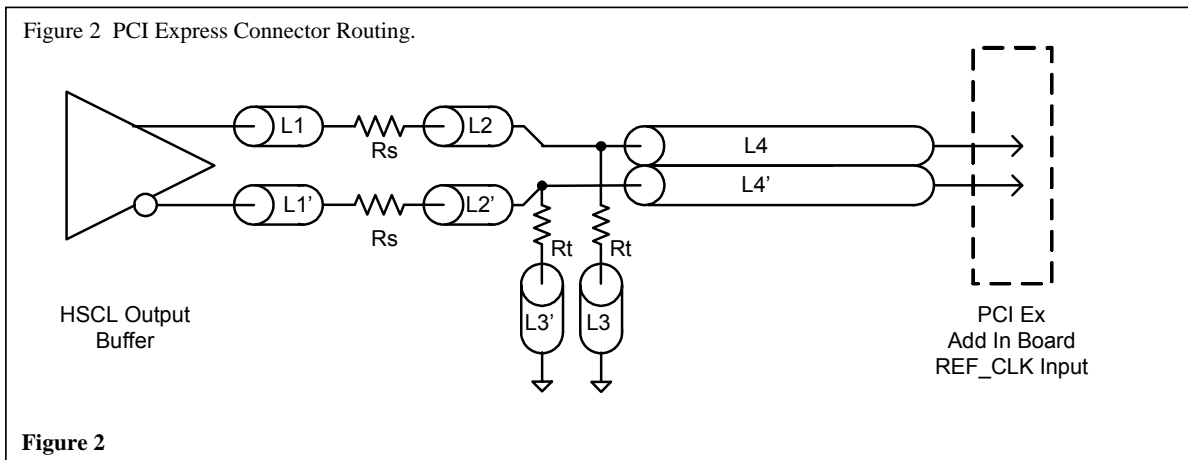
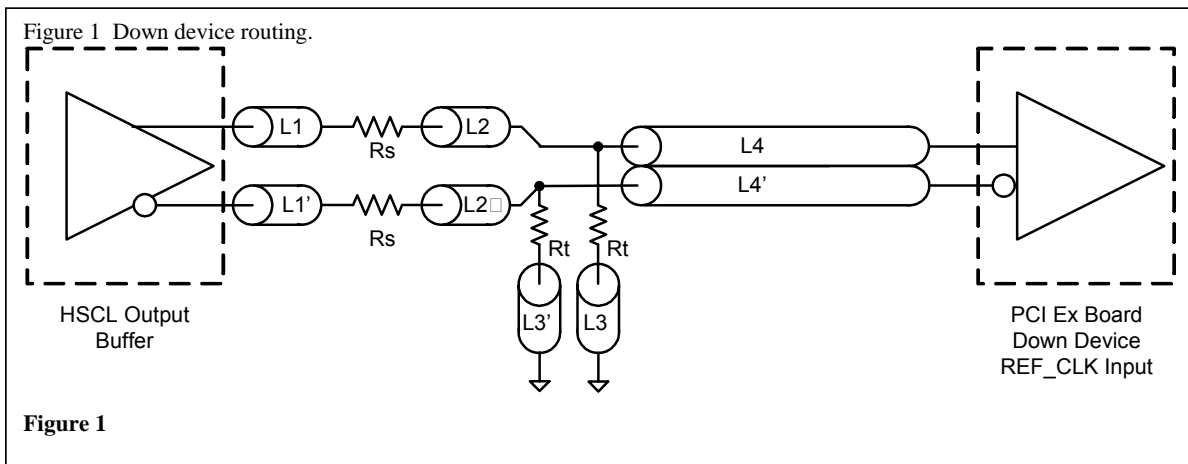

Alternative termination for LVDS and other common differential signals. Figure 3.

Vdiff	Vp-p	Vcm	R1	R2	R3	R4	Note
0.45 v	0.22v	1.08	33	150	100	100	
0.58	0.28	0.6	33	78.7	137	100	
0.80	0.40	0.6	33	78.7	none	100	ICS874003i-02 input compatible
0.60	0.3	1.2	33	174	140	100	Standard LVDS

R1a = R1b = R1

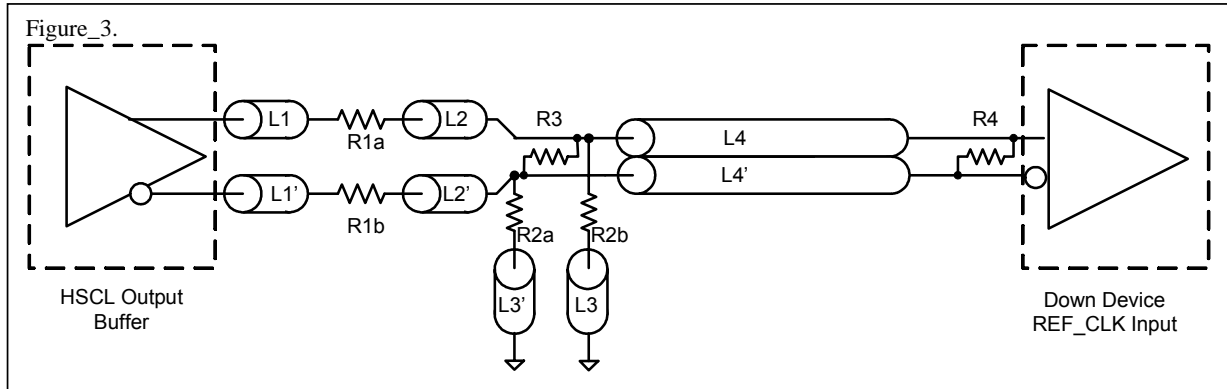

R2a = R2b = R2

Cable connected AC coupled application, figure 4

Component	Value	Note
R5a,R5b	8.2K 5%	
R6a,R6b	1K 5%	
Cc	0.1 uF	
Vcm	0.350 volts	

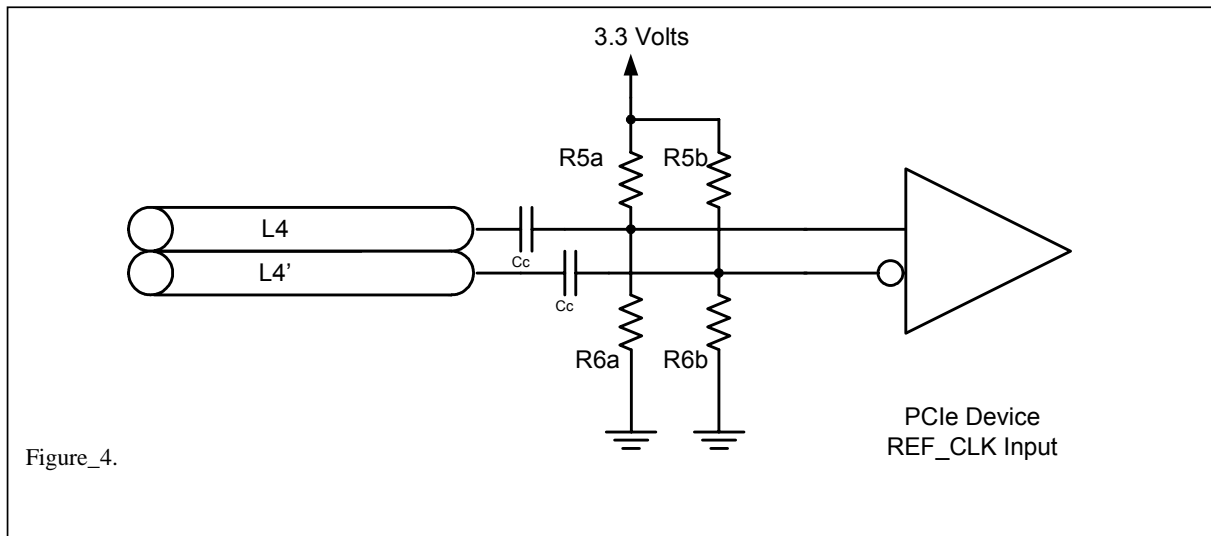

48-pin SSOP Package Drawing and Dimensions

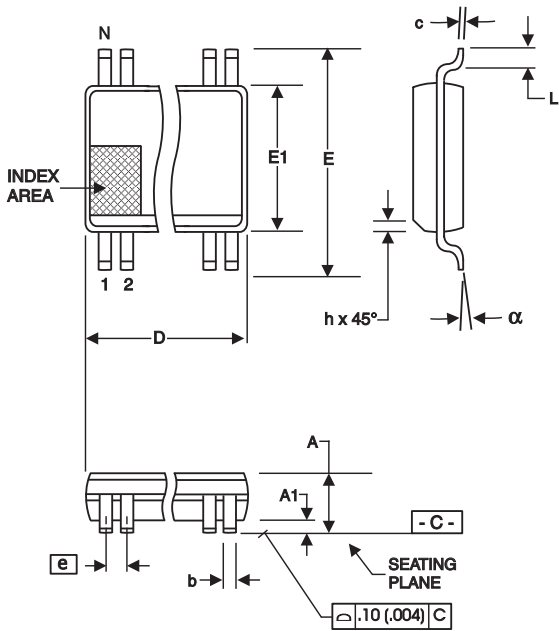

48-Lead 300 mil SSOP

SYMBOL	In Millimeters COMMON DIMENSIONS		In Inches COMMON DIMENSIONS	
	MIN	MAX	MIN	MAX
A	2.41	2.80	.095	.110
A1	0.20	0.40	.008	.016
b	0.20	0.34	.008	.0135
c	0.13	0.25	.005	.010
D	SEE VARIATIONS		SEE VARIATIONS	
E	10.03	10.68	.395	.420
E1	7.40	7.60	.291	.299
e	0.635 BASIC		0.025 BASIC	
h	0.38	0.64	.015	.025
L	0.50	1.02	.020	.040
N	SEE VARIATIONS		SEE VARIATIONS	
α	0°	8°	0°	8°

VARIATIONS

N	D mm.		D (inch)	
	MIN	MAX	MIN	MAX
48	15.75	16.00	.620	.630

Reference Doc.: JEDEC Publication 95, MO-118

10-0034

48-pin TSSOP Package Drawing and Dimensions

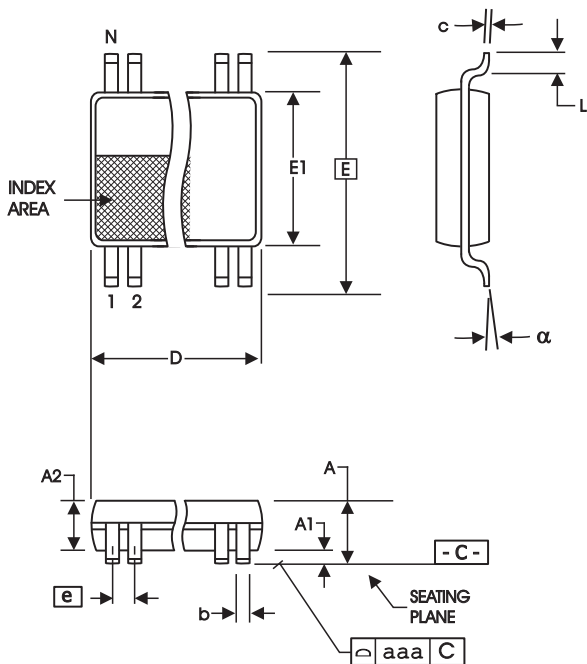

48-Lead, 6.10 mm. Body, 0.50 mm. Pitch TSSOP
(240 mil) (20 mil)

SYMBOL	In Millimeters COMMON DIMENSIONS		In Inches COMMON DIMENSIONS	
	MIN	MAX	MIN	MAX
A	--	1.20	--	.047
A1	0.05	0.15	.002	.006
A2	0.80	1.05	.032	.041
b	0.17	0.27	.007	.011
c	0.09	0.20	.0035	.008
D	SEE VARIATIONS		SEE VARIATIONS	
E	8.10 BASIC		0.319 BASIC	
E1	6.00	6.20	.236	.244
e	0.50 BASIC		0.020 BASIC	
L	0.45	0.75	.018	.030
N	SEE VARIATIONS		SEE VARIATIONS	
α	0°	8°	0°	8°
aaa	--	0.10	--	.004

VARIATIONS

N	D mm.		D (inch)	
	MIN	MAX	MIN	MAX
48	12.40	12.60	.488	.496

Reference Doc.: JEDEC Publication 95, MO-153

10-0039

Ordering Information

Part / Order Number	Compliance			Marking	Shipping Packaging	Package	Temperature
	FBD	PCIe Gen1	PCIe Gen2				
9FG108CGLF ¹		X		9FG108CGLF	Tubes	48-pin TSSOP	0 to +70° C
9FG108CGLFT ¹		X		9FG108CGLF	Tape and Reel	48-pin TSSOP	0 to +70° C
9FG108CFLF ¹		X		9FG108CFLF	Tray	48-pin SSOP	0 to +70° C
9FG108CFLFT ¹		X		9FG108CFLF	Tape and Reel	48-pin SSOP	0 to +70° C
9FG108DGLF	X	X	X	9FG108DGLF	Tubes	48-pin TSSOP	0 to +70° C
9FG108DGLFT	X	X	X	9FG108DGLF	Tape and Reel	48-pin TSSOP	0 to +70° C
9FG108DGILF	X	X	X	9FG108DGILF	Tubes	48-pin TSSOP	-40 to +85° C
9FG108DGILFT	X	X	X	9FG108DGILF	Tape and Reel	48-pin TSSOP	-40 to +85° C
9FG108DFLF	X	X	X	9FG108DFLF	Tray	48-pin SSOP	0 to +70° C
9FG108DFLFT	X	X	X	9FG108DFLF	Tape and Reel	48-pin SSOP	0 to +70° C
9FG108DFILF	X	X	X	9FG108DFILF	Tray	48-pin SSOP	-40 to +85° C
9FG108DFILFT	X	X	X	9FG108DFILF	Tape and Reel	48-pin SSOP	-40 to +85° C

¹Not recommended for new designs. Support for current designs only.

Revision History

Rev.	Issue Date	Description	Page #
C	6/1/2005	1. Updated SMBus Byte 0 Bit 6 and 4. 2. Updated LF Ordering Information to RoHS Compliant.	9, 15-16
D	1/13/2006	1. Corrected Pin-Type for Pin 5. 2. Corrected Revision History Rev. Sequence.	2, 17
E	4/13/2006	1. Added +/- 150 ppm accuracy spec for 100 MHz outputs.	1, 6
F	4/2/2007	Added Phase Jitter Table	14
G	4/6/2007	Updated Pin 26 Description.	4
H	2/22/2008	Fixed Pin 44 Typo	4
I	12/9/2008	Removed ICS prefix from ordering information	17-18
J	2/20/2009	Fixed Pin 26 Typo	4
		Moved electrical tables before SMBus registers and renumbered	5-16
		Added I-Temp Electrical Table	8-10
		Revised Phase Jitter tables	7
		Revised Package Outline and Ordering Information	20, 21

Innovate with IDT and accelerate your future networks. Contact:

www.IDT.com

For Sales

800-345-7015
408-284-8200
Fax: 408-284-2775

For Tech Support

408-284-6578
pcclockhelp@idt.com

Corporate Headquarters

Integrated Device Technology, Inc.
6024 Silver Creek Valley Road
San Jose, CA 95138
United States
800 345 7015
+408 284 8200 (outside U.S.)

Asia Pacific and Japan

Integrated Device Technology
Singapore (1997) Pte. Ltd.
Reg. No. 199707558G
435 Orchard Road
#20-03 Wisma Atria
Singapore 238877
+65 6 887 5505

Europe

IDT Europe, Limited
Prime House
Barnett Wood Lane
Leatherhead, Surrey
United Kingdom KT22 7DE
+44 1372 363 339

