

DASH NUMBER	CABLES ACCOMMODATED	A MAX	ASSEMBLE PER
-201	M17/176-00002	1.80	TAI-166
-202	TWC-78-1		
-203	TWC-124-1A		
-204	10602, RAYCHEM		
-205	TWAC-78-1F2		
-206	7826D0130, RAYCHEM		
-207	83310 BELDEN		
-208	202-3927, MICRODOT		
-209	202-3942, MICRODOT		
-210	8451 BELDEN		
-211	202-3934 MICRODOT	1.55	TAI-138
-212	2524E0114, RAYCHEM		
-213	TWC-78-2		
-214	TWC-124-2		
-215	BL-982 TIMES		
-216	BL-1242 TIMES		
-217	GC875TM24H, GRUMMAN	1.80	TAI-166
-218	EPD221888, RAYCHEM		
-219	2526D1114, RAYCHEM		
-220	GC875RRI, GRUMMAN		
-221	10614, RAYCHEM		
-222	10613, RAYCHEM		
-223	HMS2-1149, HUGHES		
-224	TWCP-124-3		
-225	PS665PL, PRIME STOCK	1.55	TAI-138

DATA CONTAINED IN THIS DOCUMENT IS PROPRIETARY TO TROMPETER ELECTRONICS INC. AND SHALL NOT BE DISCLOSED, COPIED OR USED FOR PROCUREMENT OR MANUFACTURE WITHOUT EXPRESS WRITTEN PERMISSION.

**REVISIONS**

REV	DESCRIPTIONS	DATE	APPROVED
R	REVISED PER ECO 16929	6/4/09	UMEX

DASH NUMBER	CABLES ACCOMMODATED	A MAX	ASSEMBLE PER
-301	GC875GCI, GRUMMAN	1.80	TAI-168
-302	GC875GB1, GRUMMAN 5022E5111, RAYCHEM		
-303	7528A5314, RAYCHEM		
-304			
-305	M17/177-00001 295-3804 MICRODOT	1.80	TAI-218
-306	TRC-50-2 M17/134-00002		
-307	TRC-75-1		
-308	TRC-75-2		
-309	TRC-50-1		

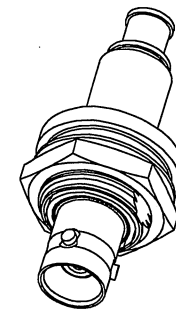

SCALE 1/1

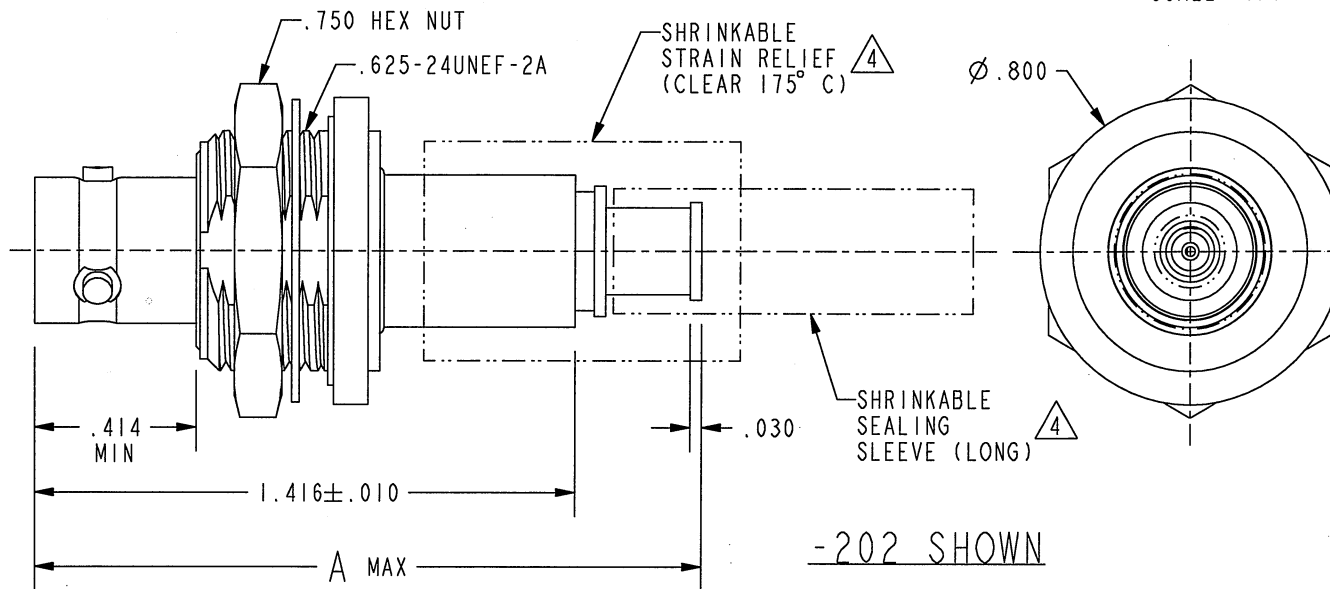

5. EXAMPLE OF COMPLETE MODEL NUMBER:

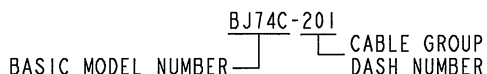

4 I SHRINKABLE STRAIN RELIEF AND/OR SHRINKABLE SEALING SLEEVE SUPPLIED LOOSE AS FOLLOWS:

- a. CABLE GROUPS -201 THROUGH -210, -217 THROUGH -303, -305, -307 AND -309

1 SHRINKABLE STRAIN RELIEF (1.00 LONG)  
1 SHRINKABLE SEALING SLEEVE (1.25 LONG)

- b. CABLE GROUPS -211 THROUGH -216, -224, -225, -306 AND -308

1 SHRINKABLE STRAIN RELIEF (1.75 LONG)

3. MAXIMUM PANEL THICKNESS: .140

2. CONCENTRIC TWINAX/TRIAX TRB, INSULATED FULL CRIMP BULKHEAD MOUNT CABLE RECEPTACLE

1. FINISH: NICKEL

NOTES: UNLESS OTHERWISE SPECIFIED.

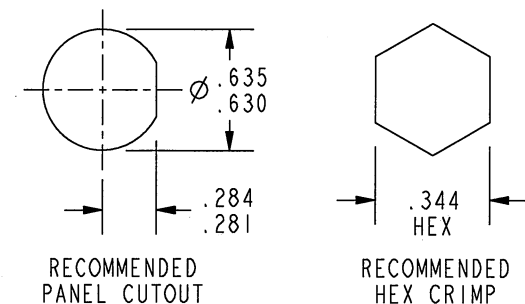

INTERPRET DRAWING PER MIL-STD-100. DIMENSIONS ARE IN INCHES AND INCLUDE FINISH THICKNESS UNLESS OTHERWISE SPECIFIED.		TOL: UNLESS SPECIFIED. .XX ± .02 .XXX ± .010 ANGLE ± 1°				
DRN L.M. 5-26-09 CHR M.J. 5-29-09 QUALITY MANUF APPROVED [Signature] 5/29/09 PROJE FILE NO. 3-0201	MATERIAL:  FINISH:	TITLE: BJ74C				SIZE: A CAGE CODE: 14949
DO NOT SCALE DWG						