

System Reset IC

Monolithic IC PST85XX Series

Outline

This is a reset IC with In various CPU systems or other logic systems, when the time of a power supply injection and a power supply are severed for a moment, this IC detects supply voltage and applies reset to a system.

PST85 has separated the detecting voltage monitor terminal (VS) and the VDD terminal. Even if monitor voltage VS falls, when an operating limit is reached for another power supply, an output does not become unfixed, and the power supply of IC can maintain low level. It is especially suitable for the power supply surveillance of the low power supply (1V system).

Features

- | | |
|--------------------------------|--|
| 1. High Accuracy | Typ±0.8% (VTH=0.8~1.9V)
Typ±0.5% (VTH=2.0~6.0V) |
| 2. Super low supply current | Typ 0.35μA |
| 3. Operating-voltage range | 0.70V~10V |
| 4. Operating-temperature range | -40~+105°C |
| 5. Detecting voltage rank | 1.2V~6.0V (0.1Vstep) |
| 6. Output type | CMOS output (PST851)
Open drain output (PST852) |

Packages

- SSON-4
- SC-82ABB
- SOT-25A

Applications

1. Reset circuits for CPUs and MPUs
2. Reset circuits for logic circuits
3. Battery voltage check circuits
4. Change circuit of a backup circuit
5. Level detector

Block Diagram

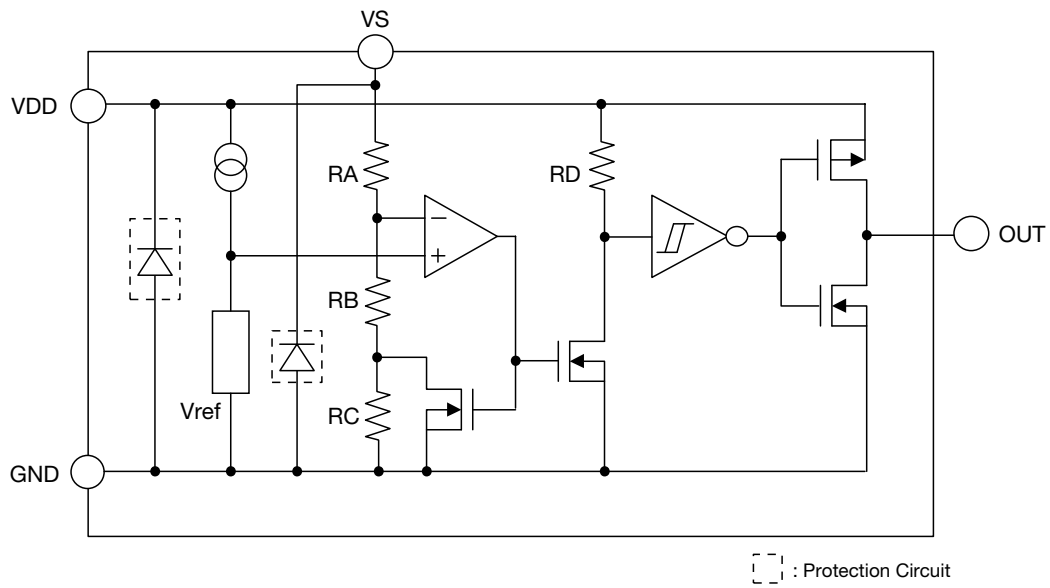

Pin Assignment

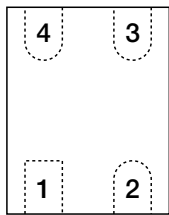

SSON-4
(TOP VIEW)

1	GND
2	OUT
3	VS
4	VDD

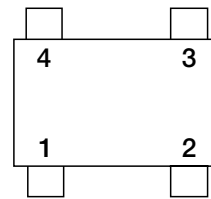

SC-82ABB
(TOP VIEW)

1	GND
2	VDD
3	VS
4	OUT

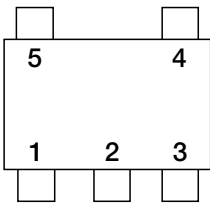

SOT-25A
(TOP VIEW)

1	OUT
2	VDD
3	GND
4	NC
5	VS

• Any products mentioned in this catalog are subject to any modification in their appearance and others for improvements without prior notification.
 • The details listed here are not a guarantee of the individual products at the time of ordering. When using the products, you will be asked to check their specifications.

Pin Description

SSON-4

Pin No.	Pin name	Functions
1	GND	GND Pin
2	OUT	Reset Signal Output Pin
3	VS	Sence Pin
4	V _{DD}	V _{DD} Pin

SC-82ABB

Pin No.	Pin name	Functions
1	GND	GND Pin
2	V _{DD}	V _{DD} Pin
3	VS	Sence Pin
4	OUT	Reset Signal Output Pin

SOT-25A

Pin No.	Pin name	Functions
1	OUT	Reset Signal Output Pin
2	V _{DD}	V _{DD} Pin
3	GND	GND Pin
4	NC	No Connection
5	VS	Sence Pin

Absolute Maximum Ratings

Item	Symbol	Ratings	Units
Supply voltage	V _{DD} max.	-0.3~+12.0	V
Output voltage	OUT	PST851	-0.3~(V _{DD} +0.3)
		PST852	-0.3~+12.0
Output voltage	VS	-0.3~+12.0	V
Input current (V _{DD})	I _{DD}	20	mA
Output current (RESET, $\overline{\text{RESET}}$)	I _{OUT}	20	mA
Power dissipation	P _D	SSON-4	330 (Note1)
		SC-82ABB	150
		SOT-25A	150
Operating temperature	T _{OPR}	-40~+105	°C
Storage temperature	T _{STG}	-65~+150	°C

Note1 : With PC board of glass epoxy. (The tab pin is not connected with PC board.)
 PC board size of 110×40×0.8mm

Recommended Operating Conditions

Item	Symbol	Ratings	Units
Operating temperature	T _{OPR}	-40~+105	°C
Supply voltage	V _{DD}	+0.70~+10.0	V

Model Name

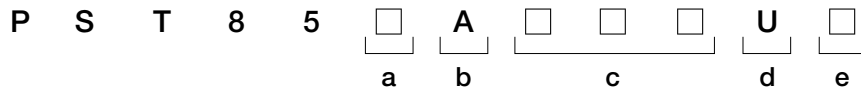

a		b		c		d		e	
Output Type		Delay Pin		VDET Rank		Package		Packing Specifications	
1	Push Pull	A	No	080	$V_{TH}=0.80V$	R	SSON-4B	R	R HOUSING Halogen-contained Product
2	Open Drain			2	2	U	SC-82ABB	L	L HOUSING Halogen-contained Product
				600	$V_{TH}=6.00V$	N	SOT-25A	M	R HOUSING Halogen-free Product
								H	L HOUSING Halogen-free Product

note1 : This device is tested at $T_a=25^{\circ}C$, over temperature limits guaranteed by design only.

- Any products mentioned in this catalog are subject to any modification in their appearance and others for improvements without prior notification.
- The details listed here are not a guarantee of the individual products at the time of ordering. When using the products, you will be asked to check their specifications.

Electrical Characteristics

(Except where noted otherwise Ta=25°C)

Item	Symbol	Measurement conditions	Rank	Min.	Typ.	Max.	Units	Circuit
Reset threshold	V _{TH}	VDD=V _{TH} +1V Ta=+25°C Ta=-40~+85°C	0.8V	0.7936	0.8000	0.8064	V	2
				0.7800		0.8200		
			0.9V	0.8928	0.9000	0.9072		
				0.8775		0.9225		
			1.0V	0.9920	1.0000	1.0080		
				0.9750		1.0250		
			1.1V	1.0912	1.1000	1.1088		
				1.0725		1.1275		
			1.2V	1.1904	1.2000	1.2096		
				1.1700		1.2300		
			1.3V	1.2896	1.3000	1.3104		
				1.2675		1.3325		
			1.4V	1.3888	1.4000	1.4112		
				1.3650		1.4350		
			1.5V	1.4880	1.5000	1.5120		
				1.4625		1.5375		
			1.6V	1.5872	1.6000	1.6128		
				1.5600		1.6400		
			1.7V	1.6864	1.7000	1.7136		
				1.6575		1.7425		
			1.8V	1.7856	1.8000	1.8144		
				1.7550		1.8450		
			1.9V	1.8848	1.9000	1.9152		
				1.8525		1.9475		
			2.0V	1.9900	2.0000	2.0100		
				1.9500		2.0500		
			2.1V	2.0895	2.1000	2.1105		
				2.0475		2.1525		
			2.2V	2.1890	2.2000	2.2110		
				2.1450		2.2550		
			2.3V	2.2885	2.3000	2.3115		
				2.2425		2.3575		
			2.4V	2.3880	2.4000	2.4120		
				2.3400		2.4600		
			2.5V	2.4875	2.5000	2.5125		
				2.4375		2.5625		
2.6V	2.5870	2.6000	2.6130					
	2.5350		2.6650					
2.7V	2.6865	2.7000	2.7135					
	2.6325		2.7675					
2.8V	2.7860	2.8000	2.8140					
	2.7300		2.8700					
2.9V	2.8855	2.9000	2.9145					
	2.8275		2.9725					
3.0V	2.9850	3.0000	3.0150					
	2.9250		3.0750					

• Any products mentioned in this catalog are subject to any modification in their appearance and others for improvements without prior notification.
 • The details listed here are not a guarantee of the individual products at the time of ordering. When using the products, you will be asked to check their specifications.

Item	Symbol	Measurement conditions	Rank	Min.	Typ.	Max.	Units	Circuit
Reset threshold	V _{TH}	VDD=V _{TH} +1V Ta=+25°C Ta=-40~+85°C	3.1V	3.0845	3.1000	3.1155	V	2
				3.0225		3.1775		
			3.2V	3.1840	3.2000	3.2160		
				3.1200		3.2800		
			3.3V	3.2835	3.3000	3.3165		
				3.2175		3.3825		
			3.4V	3.3830	3.4000	3.4170		
				3.3150		3.4850		
			3.5V	3.4825	3.5000	3.5175		
				3.4125		3.5875		
			3.6V	3.5820	3.6000	3.6180		
				3.5100		3.6900		
			3.7V	3.6815	3.7000	3.7185		
				3.6075		3.7925		
			3.8V	3.7810	3.8000	3.8190		
				3.7050		3.8950		
			3.9V	3.8805	3.9000	3.9195		
				3.8025		3.9975		
			4.0V	3.9800	4.0000	4.0200		
				3.9000		4.1000		
			4.1V	4.0795	4.1000	4.1205		
				3.9975		4.2025		
			4.2V	4.1790	4.2000	4.2210		
				4.0950		4.3050		
			4.3V	4.2785	4.3000	4.3215		
				4.1925		4.4075		
			4.4V	4.3780	4.4000	4.4220		
				4.2900		4.5100		
			4.5V	4.4775	4.5000	4.5225		
				4.3875		4.6125		
			4.6V	4.5770	4.6000	4.6230		
				4.4850		4.7150		
			4.7V	4.6765	4.7000	4.7235		
				4.5825		4.8175		
			4.8V	4.7760	4.8000	4.8240		
				4.6800		4.9200		
4.9V	4.8755	4.9000	4.9245					
	4.7775		5.0225					
5.0V	4.9750	5.0000	5.0250					
	4.8750		5.1250					
5.1V	5.0745	5.1000	5.1255					
	4.9725		5.2275					
5.2V	5.1740	5.2000	5.2260					
	5.0700		5.3300					
5.3V	5.2735	5.3000	5.3265					
	5.1675		5.4325					
5.4V	5.3730	5.4000	5.4270					
	5.2650		5.5350					
5.5V	5.4725	5.5000	5.5275					
	5.3625		5.6375					
5.6V	5.5720	5.6000	5.6280					
	5.4600		5.7400					

• Any products mentioned in this catalog are subject to any modification in their appearance and others for improvements without prior notification.
 • The details listed here are not a guarantee of the individual products at the time of ordering. When using the products, you will be asked to check their specifications.

Item	Symbol	Measurement conditions	Rank	Min.	Typ.	Max.	Units	Circuit			
Reset threshold	V_{TH}	$V_{DD}=V_{TH}+1V$ $T_a=+25^{\circ}C$ $T_a=-40\sim+85^{\circ}C$	5.7V	5.6715	5.7000	5.7285	V	2			
				5.5575		5.8425					
			5.8V	5.7710	5.8000	5.8290					
				5.6550		5.9450					
			5.9V	5.8705	5.9000	5.9295					
				5.7525		6.0475					
			6.0V	5.9700	6.0000	6.0300					
				5.8500		6.1500					
			Reset threshold hysteresis	ΔV_{TH}	$V_{DD}=V_{TH}+1V$ $V_S=0V \rightarrow V_{TH}+1V \rightarrow 0V$	0.8V			0.024	0.040	0.064
						0.9V			0.027	0.045	0.072
						1.0V			0.030	0.050	0.080
						1.1V			0.033	0.055	0.088
1.2V	0.036	0.060				0.096					
1.3V	0.039	0.065				0.104					
1.4V	0.042	0.070				0.112					
1.5V	0.045	0.075				0.120					
1.6V	0.048	0.080				0.128					
1.7V	0.051	0.085				0.136					
1.8V	0.054	0.090				0.144					
1.9V	0.057	0.095				0.152					
2.0V	0.060	0.100				0.160					
2.1V	0.063	0.105				0.168					
2.2V	0.066	0.110				0.176					
2.3V	0.069	0.115				0.184					
2.4V	0.072	0.120				0.192					
2.5V	0.075	0.125				0.200					
2.6V	0.078	0.130				0.208					
2.7V	0.081	0.135				0.216					
2.8V	0.084	0.140				0.224					
2.9V	0.087	0.145				0.232					
3.0V	0.090	0.150				0.240					
3.1V	0.093	0.155				0.248					
3.2V	0.096	0.160				0.256					
3.3V	0.099	0.165				0.264					
3.4V	0.102	0.170				0.272					
3.5V	0.105	0.175				0.280					
3.6V	0.108	0.180				0.288					
3.7V	0.111	0.185				0.296					
3.8V	0.114	0.190				0.304					
3.9V	0.117	0.195				0.312					
4.0V	0.120	0.200				0.320					
4.1V	0.123	0.205				0.328					
4.2V	0.126	0.210				0.336					
4.3V	0.129	0.215				0.344					
4.4V	0.132	0.220	0.352								
4.5V	0.135	0.225	0.360								
4.6V	0.138	0.230	0.368								
4.7V	0.141	0.235	0.376								
4.8V	0.144	0.240	0.384								
4.9V	0.147	0.245	0.392								
5.0V	0.150	0.250	0.400								

• Any products mentioned in this catalog are subject to any modification in their appearance and others for improvements without prior notification.
 • The details listed here are not a guarantee of the individual products at the time of ordering. When using the products, you will be asked to check their specifications.

Item	Symbol	Measurement conditions	Rank	Min.	Typ.	Max.	Units	Circuit
Reset threshold hysteresis	ΔV_{TH}	VDD=V _{TH} +1V VS=0V→V _{TH} +1V→0V	5.1V	0.153	0.255	0.408	V	2
			5.2V	0.156	0.260	0.416		
			5.3V	0.159	0.265	0.424		
			5.4V	0.162	0.270	0.432		
			5.5V	0.165	0.275	0.440		
			5.6V	0.168	0.280	0.448		
			5.7V	0.171	0.285	0.456		
			5.8V	0.174	0.290	0.464		
			5.9V	0.177	0.295	0.472		
6.0V	0.180	0.300	0.480					
Supply current	I _{DD}	VDD=V _{TH} +1V VS=V _{TH} +1V	0.8V ~ 6.0V		0.35	1.0	μA	1
Reset threshold temp. coefficient	$\Delta V_{TH}/^{\circ}C$ (Note3)	Ta=-40~+85°C	0.8V ~ 6.0V		±100		ppm/°C	2
"L" Transfer delay time	t _{PHL} (Note3)	VDD=V _{TH} +0.4V VS=V _{TH} +0.4V→V _{TH} -0.4V (Note3)	0.8V ~ 6.0V	2	15	100	μs	5
"H" Transfer delay time	t _{PLH} (Note3)	VDD=V _{TH} +0.4V VS=V _{TH} -0.4V→V _{TH} +0.4V (Note3)	0.8V ~ 6.0V	2	15	100	μs	5
VS Input current	I _{VS}	VDD=V _{TH} +1V VS=V _{TH} +1V	0.8V ~ 6.0V		100		nA	4
"L" Output current	I _{OL1}	VDD=VS=0.7V, VDS=0.05V	0.8V ~ 6.0V	0.01	0.10		mA	3
	I _{OL2}	VDD=VS=1.2V, VDS=0.5V V _{TH} ≥1.3V	1.3V ~ 6.0V	0.23	2.00			
	I _{OL3}	VDD=VS=2.4V, VDS=0.5V V _{TH} ≥2.5V	2.5V ~ 6.0V	1.60	8.00			
	I _{OL4}	VDD=VS=3.6V, VDS=0.5V V _{TH} ≥3.7V	3.7V ~ 6.0V	3.20	12.0			
"H" Output current	I _{OH1}	VDD=VS=4.8V, VDS=0.5V V _{TH} ≤4.7V	0.8V ~ 4.7V	0.36	0.62		mA	3
	I _{OH2}	VDD=VS=6.5V, VDS=0.5V	0.8V ~ 6.0V	0.46	0.75			

Note2 : This device is tested at Ta=25°C, over temperature limits guaranteed by design only.

Note3 : The parameter is guaranteed by design.

Test Circuit

(1)

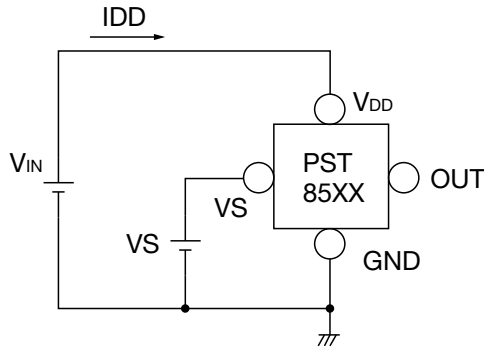

(2-1) PST851

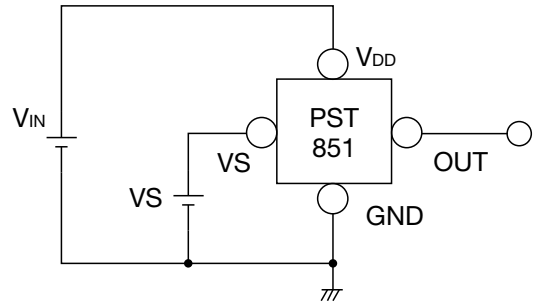

(2-2) PST852

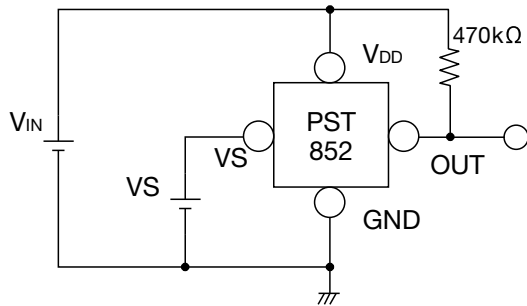

(3)

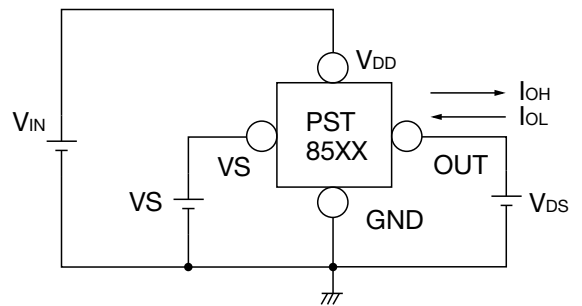

(4)

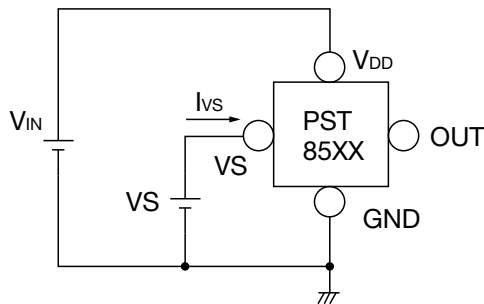

(5-1) PST851

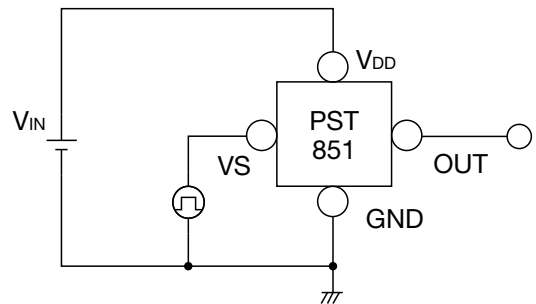

(5-2) PST852

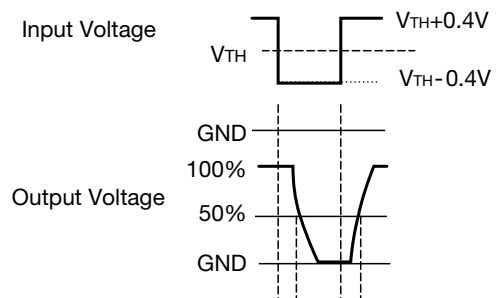
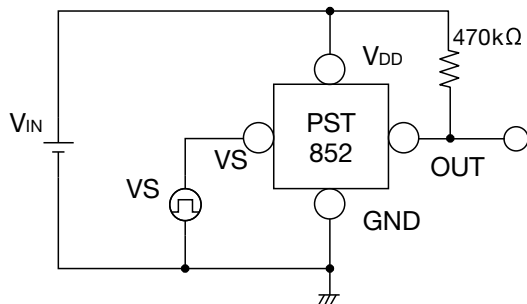

• Any products mentioned in this catalog are subject to any modification in their appearance and others for improvements without prior notification.
 • The details listed here are not a guarantee of the individual products at the time of ordering. When using the products, you will be asked to check their specifications.

Timing Chart

- The operation of the PST85XX OUT terminal when $V_{DD} < 0.7V$ or less is indefinite, however in the timing chart, OUT terminal NMOS is listed as OFF and PMOS as ON for PST851. The OUT terminal NMOS is listed as OFF for PST852.

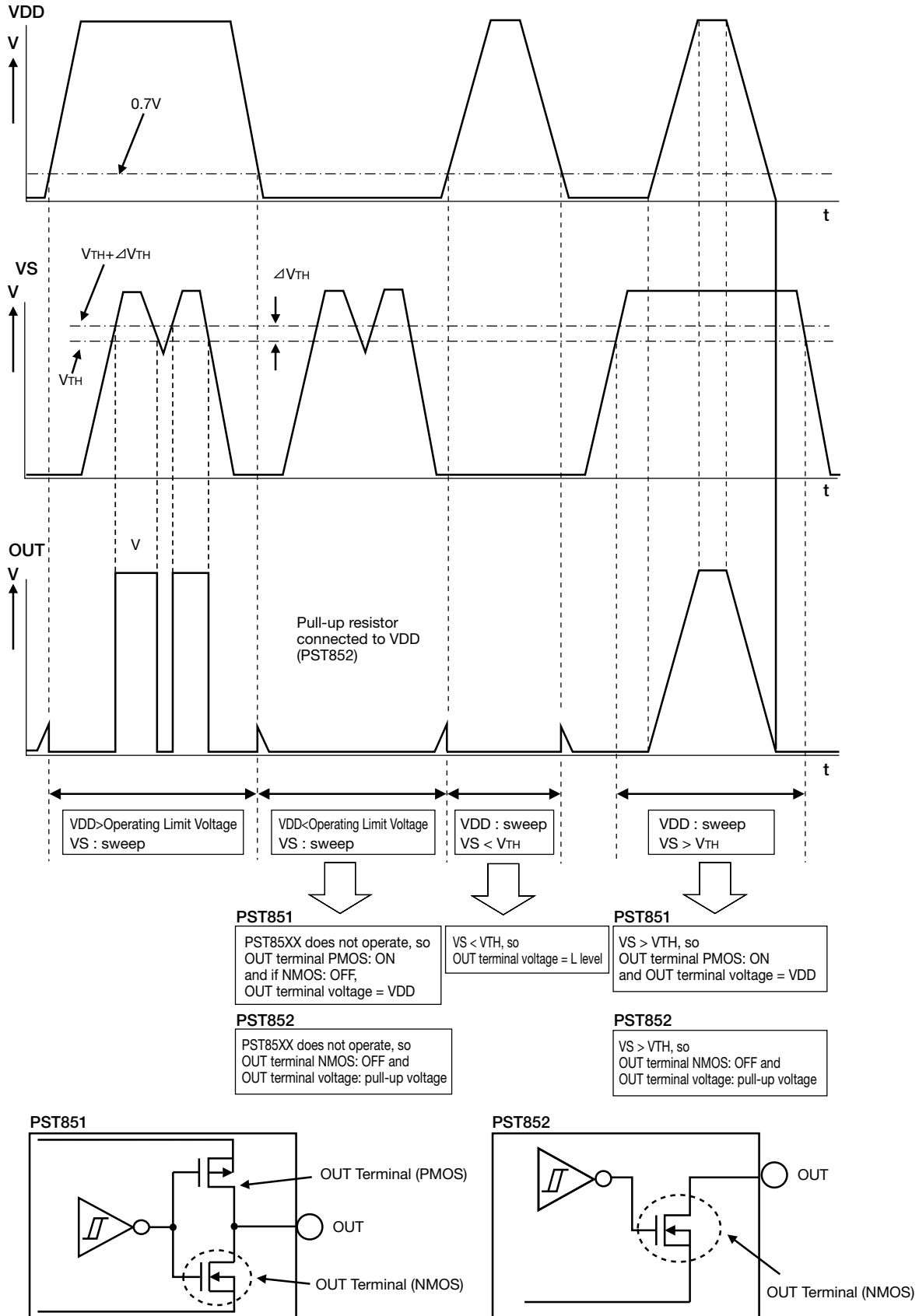

• Any products mentioned in this catalog are subject to any modification in their appearance and others for improvements without prior notification.
 • The details listed here are not a guarantee of the individual products at the time of ordering. When using the products, you will be asked to check their specifications.

Application Circuits

PST851

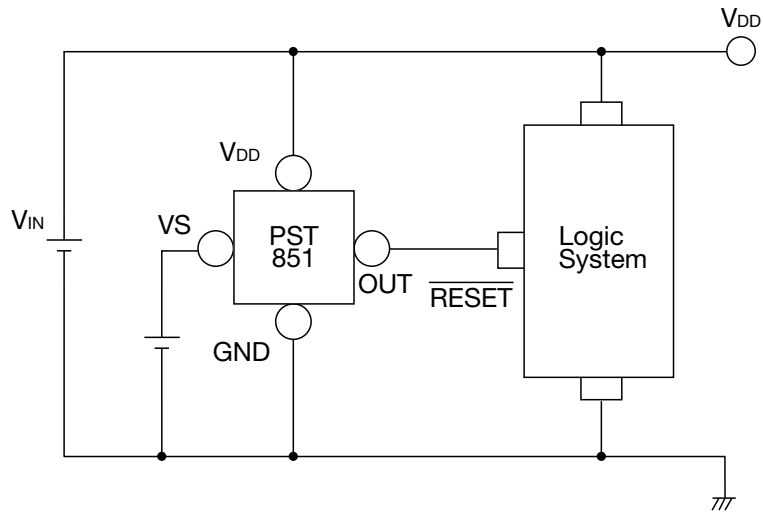

PST852

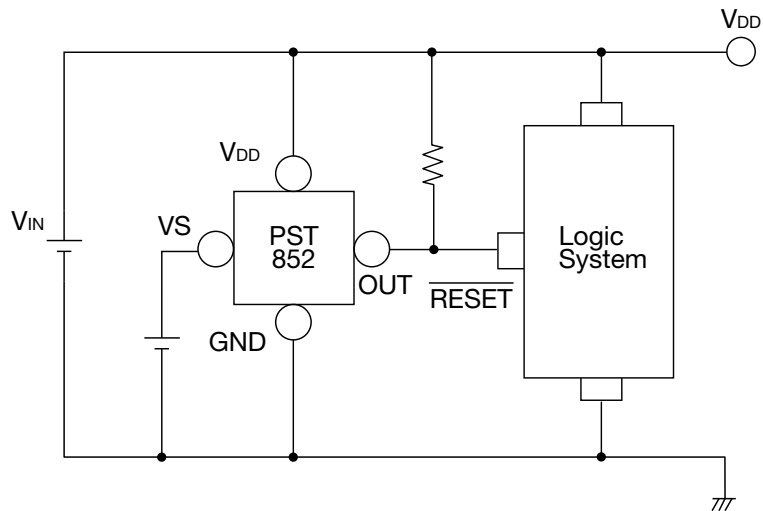

- We shall not be liable for any trouble or damage caused by using this circuit.
- In the event a problem which may affect industrial property or any other rights of us or a third party is encountered during the use of information described in these circuit, Mitsumi Electric Co., Ltd. shall not be liable for any such problem, nor grant a license therefore.

Characteristics (Typical Performance Characteristics 0.85V)

Detecting Voltage

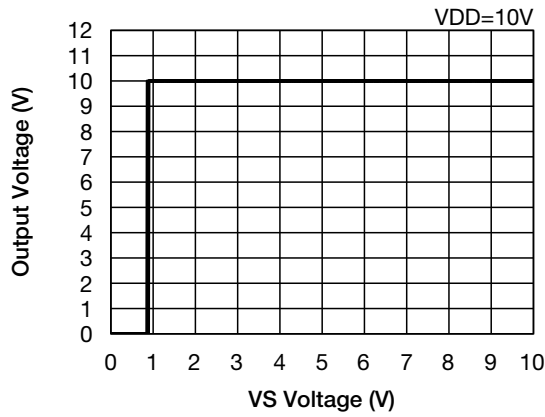

Supply Current

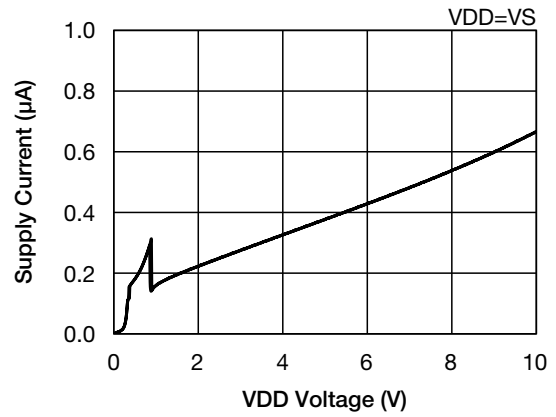

N-ch Output Current

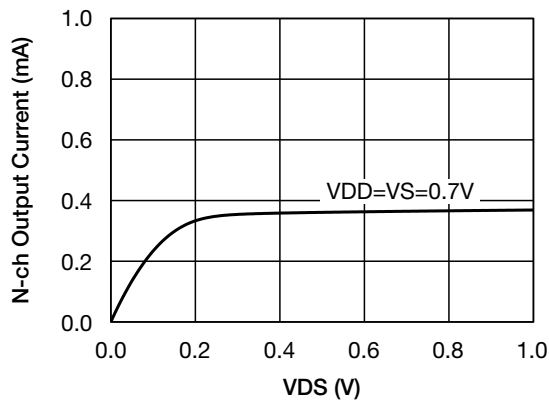

Detecting Voltage

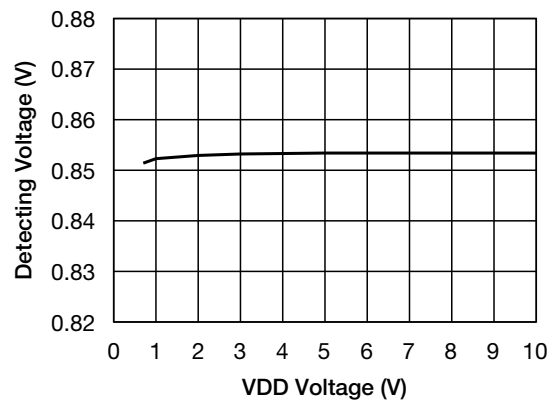

VS Input Current - VS Voltage

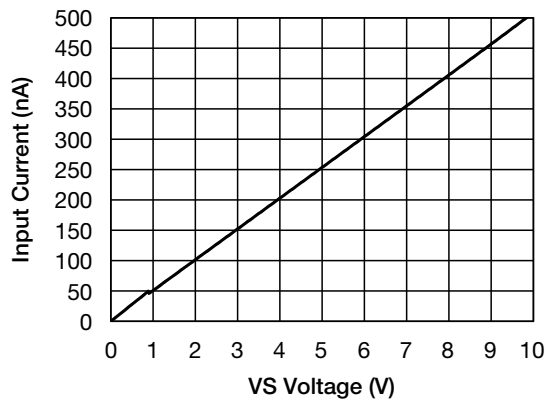

Note : * These are typical characteristics.

• Any products mentioned in this catalog are subject to any modification in their appearance and others for improvements without prior notification.
 • The details listed here are not a guarantee of the individual products at the time of ordering. When using the products, you will be asked to check their specifications.

■ Detecting Voltage - Temperature

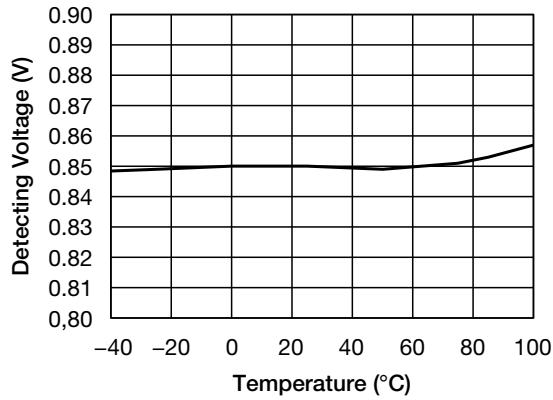

■ Hysteresis Voltage - Temperature

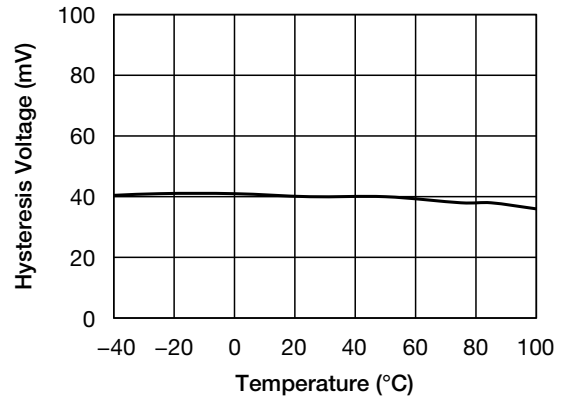

■ "L"Output Current 1 - Temperature

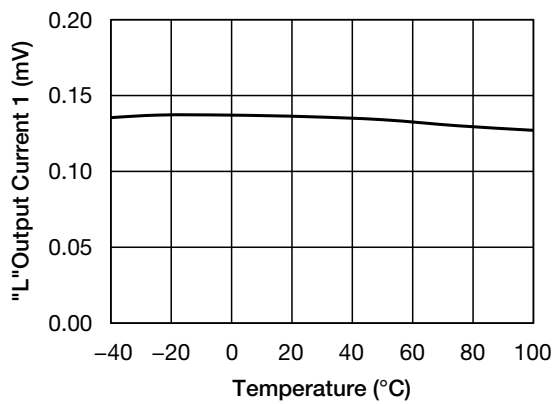

Note : * These are typical characteristics.

• Any products mentioned in this catalog are subject to any modification in their appearance and others for improvements without prior notification.
 • The details listed here are not a guarantee of the individual products at the time of ordering. When using the products, you will be asked to check their specifications.