

版数 REV.	年月日 DATE	DCN NO.	変更内容 DESCRIPTION	製図 DR.	担当 CHK.	査閲 APPD.	承認 APPD.
3	30.Mar.2000	45857	REDRAWN		Y.SAITOU		Y.HAYASHI
4	6.Dec.2005	058546	REVISED FORM SCREW		Y.TAKA@	R. Jaga	J. Kubota

TABLE-1

PANEL THICKNESS	SCREW PART NUMBER
MORE 0.2 LESS THAN 0.7	250-50265
MORE 0.7 LESS THAN 1.2	250-50266
MORE 1.7 LESS THAN 2.2	250-50268

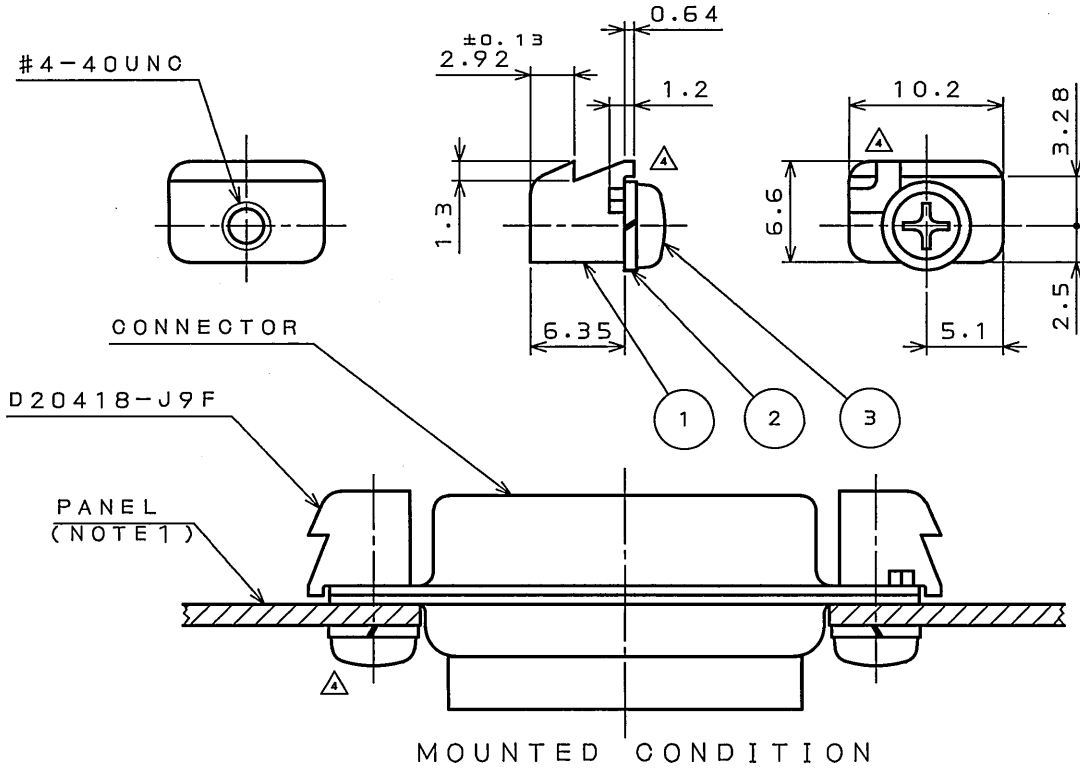

NOTE 1. APPLICABLE PANEL THICKNESS IS MORE 1.2  
LESS THAN 1.7.  
IF IT IS NOT USED, BE ORDERED ONLY SCREW  
OF ITEM NUMBER 3, SELECT FOR TABLE 1.  
2. ITEM NUMBER 2 AND 3 WHICH ARE NOT  
ASSEMBLED ARE ATTACHED.

注 1. 適合パネル厚は 1.2t 以上 1.7t 未満です。これ以外のパネルを御使用  
の際は符号③のねじのみ(表-1)から選択して御要求下さい。  
2. 符号②,③は組み立てず添付する。

3	CROSS PAN HEAD SCREW	1	STEEL	NICKEL PLATING	#4-40UNC (1=5.5)
2	SPRING LOCK WASHER	1	STEEL	NICKEL PLATING	
1	SCREW LOCK	1	ZINC ALLOY	NICKEL PLATING	#4-40UNC
符号 NO.	名称 DESCRIPTION	個数 QTY.	材料 MATERIAL	仕上 FINISH	備考 REMARKS

D0F-0-211F(05.08)

仕様書(SPECIFICATION)		第1版(ORIGINAL DATE)		名称(TITLE)	
		16.Apr.1986		D20418-J9F	
公差差(GENERAL TOLERANCE)		製図 DR.		日本航空電子工業株式会社 JAPAN AVIATION ELECTRONICS INDUSTRY, LTD.	
寸法(DIMENSION)		担当 CHK. TAKEUCHI			
角度(ANGLES)		査閲 APPD. NISHINO			
		承認 APPD. KANEDA			
±0.8	° ±			図面番号(DRAWING NO.)	
.X ±0.4	°X ±				
.XX ±0.1				SJ020883	
.XXX ±				シリーズ(SERIES) 尺度(SCALE)	
				Dsub 2:1	
				版数 (REV.)	
				4	