

Aluminium Housed Wirewound Resistors

WH Series

Features:

- High power dissipation up to 300W
- All welded construction
- Suitable for severe environments
- Designed for excellent thermal conductivity to heatsink
- Spade terminal option

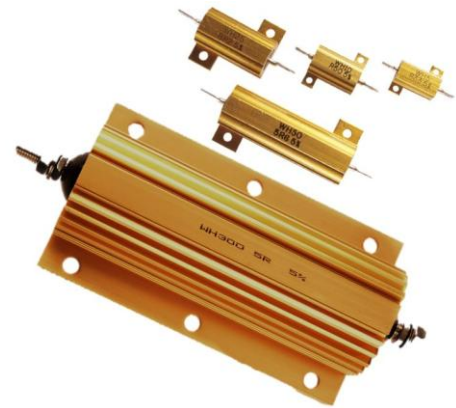

All Pb-free parts comply with EU Directive 2011/65/EU amended by (EU) 2015/863

Electrical Data

WH5 – 50 Actual Data		WH5	WH10	WH25	WH50
Power rating @25°C ¹	W	10	15	25 ²	50 ²
Resistance range	ohms	R01 to 10K	R01 to 20K	R01 to 44K	R015 to 120K
TCR (-55 to 200°C)	ppm/°C	<10R: ±75 ≥10R to <100R: ±50 ≥100R: ±25			
Resistance tolerance ³	%	<R05: 10 ≥R05 to <R50: 5, 10 ≥R50 to <1R0: 2, 5, 10 ≥1R0: 1, 2, 5, 10			
Isolation voltage	V _{dc/acpk}	1500		3000	
Limiting element voltage	V _{dc/acrms}	150	250	500	1250
Standard values		E24 preferred. Other values may be requested.			
Thermal impedance ¹	°C/W	16	10	6	3.5
Ambient temperature range	°C	-55 to 200			

Note 1: Mounted on an aluminium heatsink as described in Reference Heatsink Dimensions table, or thermal equivalent.

Note 2: WH25T and WH50T additionally have a maximum current rating of 15A.

Note 3: Tighter tolerances to 0.05% may be made available for mid-range ohmic values on request.

The requirements of the following standard are met or exceeded by the corresponding WH series products above.

IECQ-CECC 40203-006 requirements		AA	BA	CA	DA
Required power rating @25°C ¹	W	10	15	25	40
Qualified resistance range	ohms	R05 to 3K4	R05 to 15K	R05 to 33K	R05 to 82K
Required TCR (-55 to 200°C)	ppm/°C	≥5R to ≤10R: ±100 >10R: ±50			
Required resistance tolerance	%	≥R05 to <R50: 5 ≥R50 to <1R0: 2, 5 ≥1R0: 1, 2, 5			
Required isolation voltage	V _{dc/acpk}	1000		2000	

Note 1: Mounted on an aluminium heatsink as described in Reference Heatsink Dimensions table, or thermal equivalent.

WH100 – 300		WH100	WH200	WH300
Power rating @25°C ¹	W	100	200	300
Resistance range	ohms	R01 to 70K	R01 to 50K	R01 to 68K
TCR (-55 to 200°C)	ppm/°C	≤1K0: ±100 >1K0: ±25		
Resistance tolerance	%	≤R047: 10 ≥R05: 5, 10 standard. 1% & 2% may be requested.		
Isolation voltage	V _{dc/acpk}	6360	7070	
Limiting element voltage	V _{dc/acrms}	1900		2500
Standard values		E24 preferred. Other values may be requested.		
Thermal impedance ¹	°C/W	1	0.7	0.6
Ambient temperature range	°C	-55 to 200		

Note 1: Mounted on an aluminium heatsink as described in Reference Heatsink Dimensions table, or thermal equivalent.

General Note

TT Electronics reserves the right to make changes in product specification without notice or liability. All information is subject to TT Electronics' own data and is considered accurate at time of going to print.

Physical Data

Dimensions in mm and weight in g												
Type	A _{max}	B ±0.3	C ±0.3	E _{min}	F _{max}	G _{max}	H ±0.2	L _{max}	M ±0.5	N _{max}	Dt _{min}	Wt. _{nom}
WH5	30	12.4	11.3	1.9	17	9	2.4	17	4.3	1.8	2.5	3.6
WH10	36.5	15.9	14.3		21	11		21	5.2	2.2	2.9	5.6
WH25	51 ¹	19.8	18.3	2.8	28	15	3.3	29	7.2	2.6	4.3	13
WH50	72.5 ²	21.4	39.7		30	16		51	7.9		5.1	29

Type	A _{max}	B _{max}	C _{max}	D _{max}	E _{max}	F ±0.3	G ±0.3	H _{max}	J _{max}	K _{max}	L	M _{max}	Dt _{min}	Wt. _{nom}
WH100	47.5	88	24.1	27.3	65.2	35	37	11.8	15.4	3.7	4.4 ±0.25	-	7	115
WH200	72.5	145.7	41.8	45.5	89.7	70	57.2	20.5	10.4	5.5	5.1 ±0.45	103.4	15	475
WH300		184.4			127.7	104	59		12.4		6.6 ±0.45	141.4		700

Note 1: A_{max} for WH25T is 71.3mm.

Note 2: A_{max} for WH50T is 95.5mm.

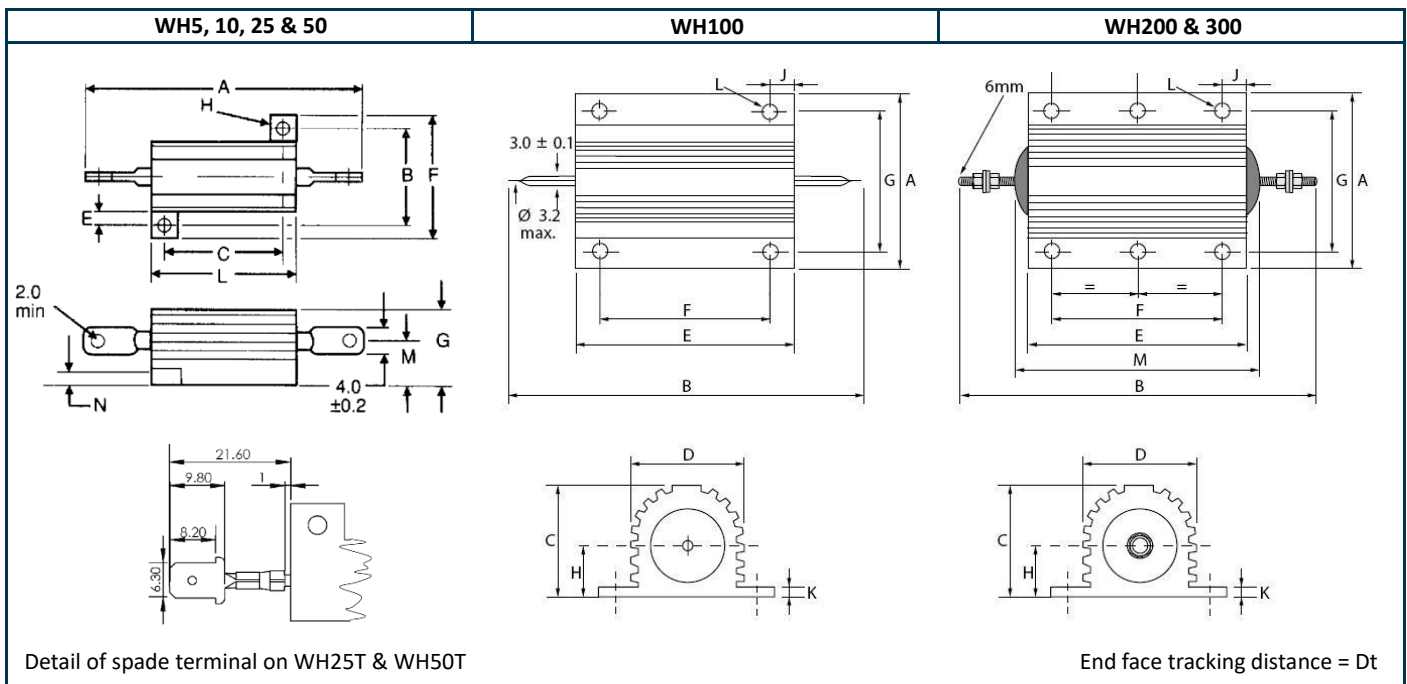

Construction

Cap and lead assemblies are fitted to a high purity ceramic substrate. The resistive element is wound onto the substrate and welded to the caps. The wound rod is then molded and fitted into aluminium housing to give optimum stability and reliability.

Marking

The resistors are legend marked with type reference, resistance value and tolerance which will withstand all accepted industrial cleaning fluids. Values are marked in accordance with IEC 60062. WH100 and larger sizes are also marked with date code (YY.WW) and country of origin.

Terminations

- WH5 - 100** Terminations are solder dipped copper-clad steel. They meet the strength requirements of IEC 60115-1 clause 9.5 and the solderability requirements of IEC 60115-1 clause 11.1.
- WH25T & 50T** Terminations are 6.35mm (¼") spade terminals.
- WH200 & 300** M6 threaded steel terminals with a set of 4 nuts and washers. The termination robustness is 50N maximum and the tightening torque is 5Nm maximum.

General Note

TT Electronics reserves the right to make changes in product specification without notice or liability. All information is subject to TT Electronics' own data and is considered accurate at time of going to print.

Performance Data

		WH5, 10, 25 & 50			WH100, 200 & 300
		IECQ-CECC 40203-006 Requirements	Actual Performance		Maximum ¹
			Maximum ¹	Typical	
Load, full rated power: 1000hrs @25°C	±ΔR%	Not specified	1	0.4	2
Load, IECQ-CECC rating: 1000hrs @25°C	±ΔR%	1	1	0.4	N/A
Dry heat: 1000hrs @200°C	±ΔR%	1	1	0.4	2
Short-term overload	±ΔR%	1	1	0.2	
Climatic sequence	±ΔR%	1	1	0.4	
Climatic category		55/200/56			
Long-term damp heat	±ΔR%	1	0.5	0.2	
Temperature rapid change	±ΔR%	0.25	0.25	0.1	0.25
Resistance to solder heat	±ΔR%	0.25	0.25	0.05	WH100: 0.5
Vibration & bump	±ΔR%	0.25	0.25	0.025	
Noise (in a decade of frequency)	μV/V	Not specified	No measurable excess noise		
Insulation resistance	ohms	≥1G0	≥10G		
Pulse and overload performance		Not specified	See Pulse and Overload Performance graphs		

Note 1: Add 0.05Ω ohmic addition for values <10R.

Pulse & Overload Performance

Overload Performance

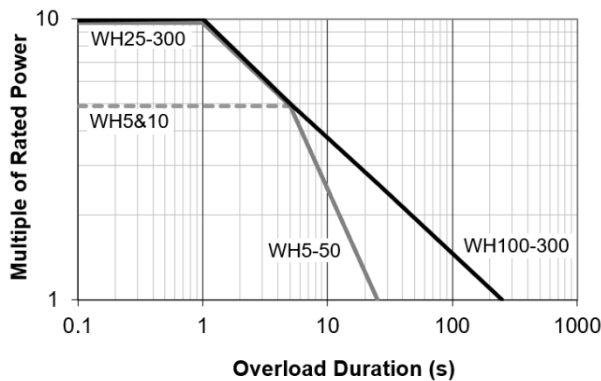

Note: For durations <0.1s use the Pulse Energy Capacity graph.

Pulse Energy Capacity

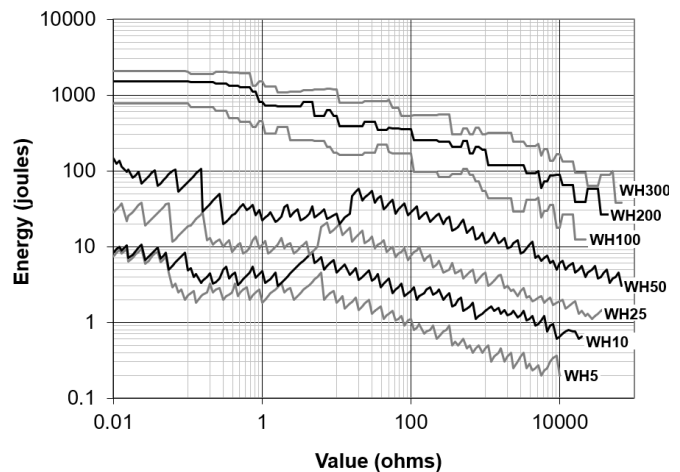

Application Notes

After soldering, care should be taken to ensure that there are no flux residues on the end faces of the molding compound, otherwise insulation resistance will be reduced. The minimum surface tracking distances from termination to casing are shown in the Physical Data tables as dimension Dt.

It is recommended that the resistor base should be coated thinly with heatsink compound before mounting so as to obtain the stated operating characteristics. The heatsink compound increases thermal conductivity to the heatsink.

The standard aluminium heatsinks are defined in the Reference Heatsink Dimensions table. If smaller heatsinks are used, then derating should be applied as indicated in the Derating for Reduced Heatsink Dimensions graph. If no heatsink is employed, use the ratings for 1cm².

General Note

TT Electronics reserves the right to make changes in product specification without notice or liability. All information is subject to TT Electronics' own data and is considered accurate at time of going to print.

© TT Electronics plc

WH Series

Reference Heatsink Dimensions

Type	IECQ-CECC Style	Al Plate Thickness (mm)	Al Plate Area (cm ²)
WH5	AA	1	410
WH10	BA		
WH25	CA		
WH50 @40W	DA	1.5	930
WH50 @50W	N/A		
WH100	N/A	3	1000
WH200			3800
WH300			5800

Derating for Reduced Heatsink Dimensions

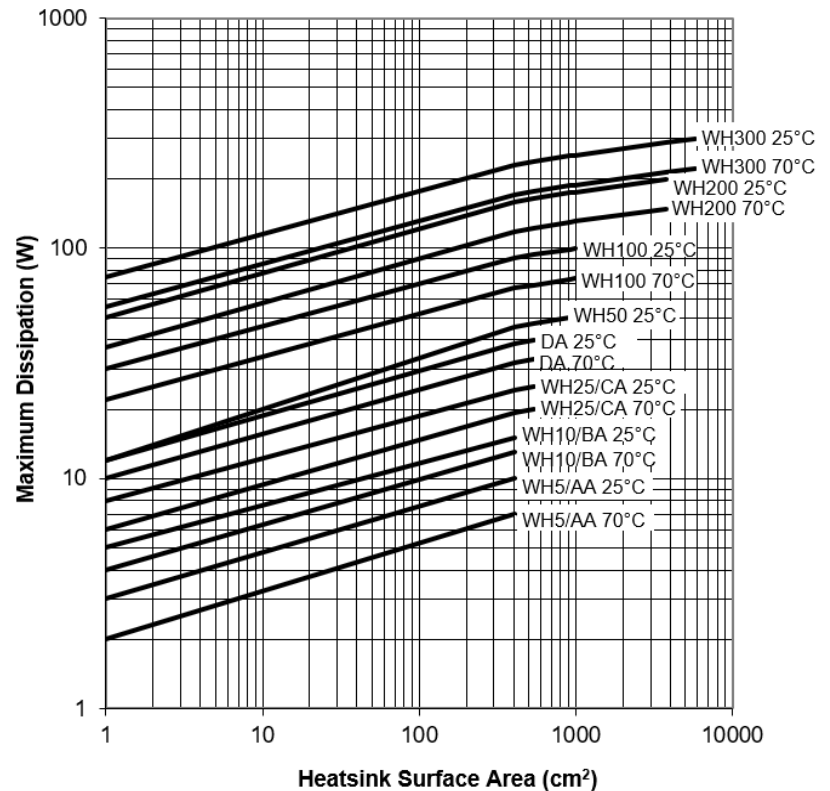

Derating for Ambient Temperature

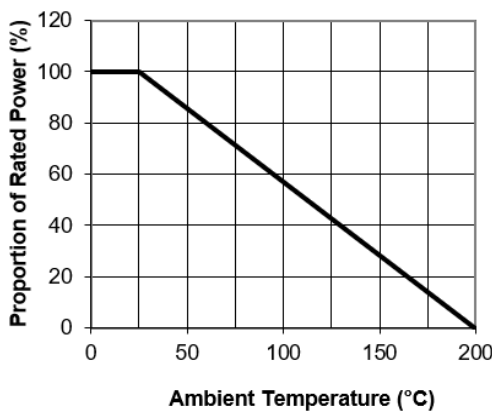

Packaging

WH resistors are bulk packed in plastic bags in boxes at the quantities shown below.

Ordering Procedure

Example: WH25-100RJ (WH25 at 100 ohms ±5%, Pb-free)

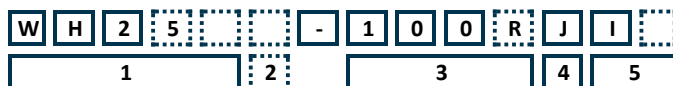

1	2	3	4	5		
Type	Termination	Value	Tolerance	Packing & Termination Finish		
WH5	Blank = standard	E24	F = ±1%	I	All types	
WH10	T = 6.35mm spade terminals (WH25 & WH50 only)	3/4 characters R = ohms K = kilohms	G = ±2%	PB	WH5, 10, 25 & 50	
WH25			J = ±5%	Standard Packing		
WH50			K = ±10%	WH5, WH10	Bulk	250/box
WH100			WH25, WH50	200/box		
WH200	WH100	45/box				
WH300	WH200, WH300	10/box				

Note: For IECQ-CECC released product (WH5, 10, 25 & 50 only) follow the MPN with text indicating the relevant release and style. Note that this additional text does not form part of our MPN.

Example: **WH25-3K3JI** IECQ-CECC40203-006 CA

General Note

TT Electronics reserves the right to make changes in product specification without notice or liability. All information is subject to TT Electronics' own data and is considered accurate at time of going to print.