

PERFORMANCE SPECIFICATION SHEET

CIRCUIT BREAKERS, MAGNETIC, UNSEALED,
TRIP-FREE, SINGLE POLE
(0.2 TO 100 AMPERES)

This specification is approved for use by all Departments and Agencies of the Department of Defense.

The requirements for acquiring the product described herein shall consist of this specification sheet and [MIL-PRF-55629](#).

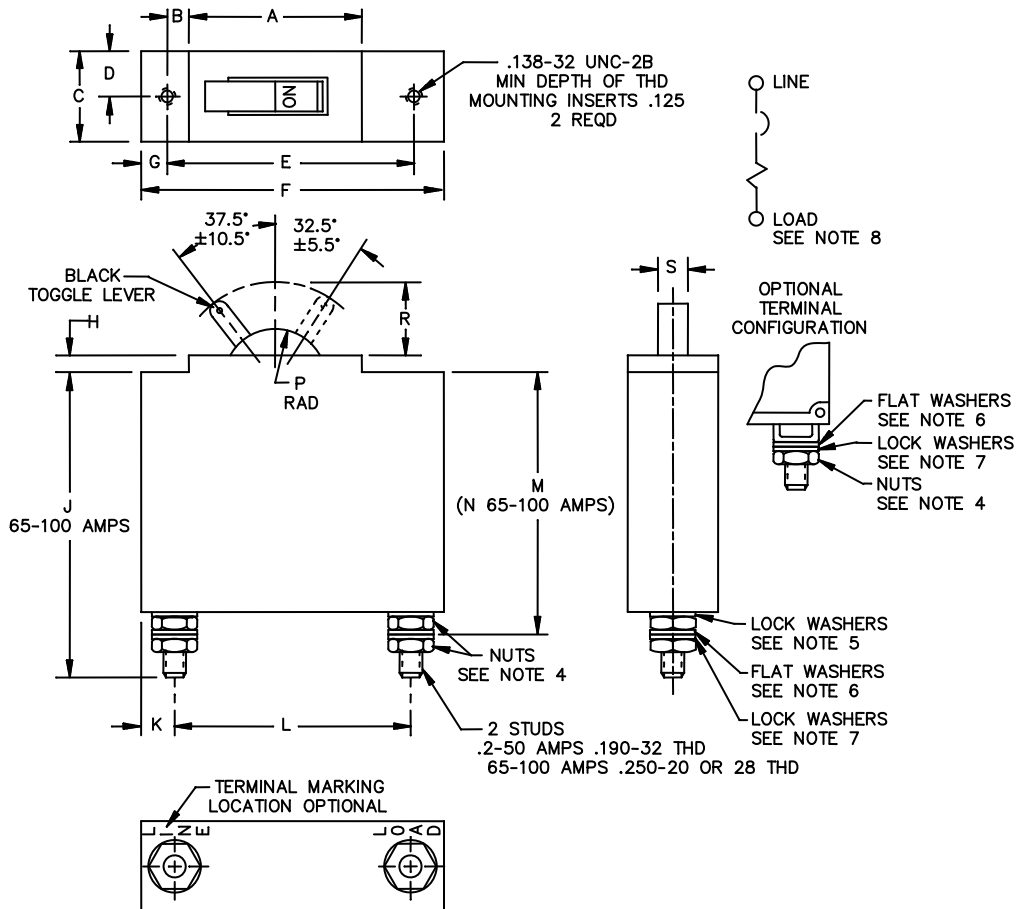

FIGURE 1. Dimensions and configurations (configuration 1).

MIL-PRF-55629/1G

Ltr	Inches		mm	
	Min	Max	Min	Max
A	1.420	1.470	36.07	37.34
B	.149	.211	3.78	5.36
C	.730	.780	18.54	19.81
D	.359	.391	9.12	9.93
E	2.046	2.078	51.97	52.78
F	---	2.530	---	64.26
G	.187	.249	4.75	6.32
H	.109	.171	2.77	4.34
J	---	2.553	---	64.85
J (65-100 amps)	---	3.125	---	79.38
K	.249	.311	6.32	7.90
L	1.660	1.960	42.16	49.78
M	1.940	2.100	49.28	53.34
N (65-100 amps)	2.060	2.340	52.33	59.44
P	---	.427 R	---	10.85 R
R	.519	.699	13.18	17.75
S	.230	.270	5.84	6.86

NOTES:

1. Dimensions are in inches.
2. Metric equivalents are given for general information only.
3. Unless otherwise specified, tolerance is ± 0.031 (0.79 mm).
4. Nut-hex: (.2 - 50 amperes) .190 - 32 UNF-2B .313/.303 across flats, .109 \pm .010 thick. (65 - 100 amperes) .250 - 28 UNF-2B .438 \pm .016 across flats or .250 - 20 UNC-2B .375 \pm .016 across flats. Material: Brass ([ASTM-B121/B121M](#) or equivalent); tin plated ([ASTM-B545](#) or equivalent); or stainless steel, for each terminal.
5. Captive washer nut assembly of brass nut, bronze washer, tin plated; or lockwasher, internal or external tooth, [NASM35333-107](#) or [MS35335-88](#) (.2 - 50 amperes), [NASM35333-108](#) or [MS35335-89](#) (65 -100 amperes) or equivalent. (Use of washers optional on 65 - 100 amperes units.)
6. Washer, flat: (.2 - 50 amperes) .378/.368 O.D., .204/.190 I.D., .032 \pm .005 thick. (65 - 100 amperes) 500 \pm .016 O.D., .281 \pm .016 I.D., .035 \pm .005 thick. Material: Brass ([ASTM-B121/B121M](#) or equivalent), tin plated ([ASTM-B545](#) or equivalent), or phosphor bronze, composition ([ASTM-B139/B139M](#) or equivalent).
7. Lockwasher, Split: (.2 - 50 amperes) [NASM35338-138](#) or equivalent. (65 - 100 amperes) [NASM35338-139](#) or equivalent.
8. Physical item marking of load terminal optional.

FIGURE 1. Dimensions and configurations (configuration 1) – Continued.

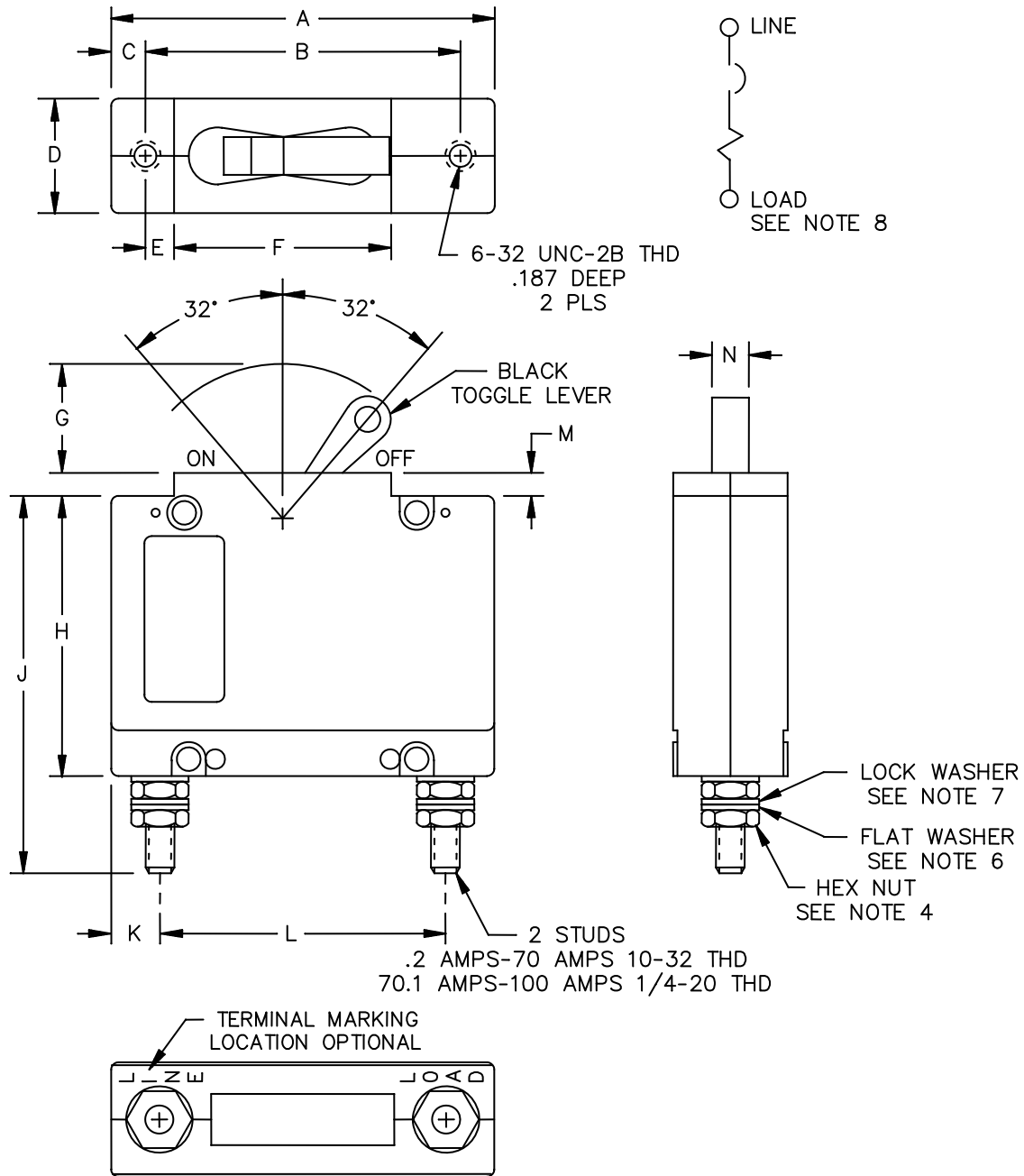

FIGURE 2. Dimensions and configurations (configuration 2).

MIL-PRF-55629/1G

Ltr	Inches		mm	
	Min	Max	Min	Max
A	2.475	2.505	62.86	63.63
B	2.045	2.075	51.94	52.71
C	.205	.235	5.21	5.97
D	---	.750	---	19.05
E	.167	.197	4.24	5.00
F	1.423	1.453	36.14	36.91
G	.535	.565	13.59	14.35
H	1.921	2.081	48.79	52.86
J	---	2.514	---	63.85
K	.266	.296	6.76	7.52
L	1.925	1.955	48.90	49.66
M	.125	.155	3.18	3.94
N	.245	.275	6.22	6.98

NOTES:

1. Dimensions are in inches.
2. Metric equivalents are given for general information only.
3. Unless otherwise specified, tolerance is $\pm .015$ (0.38 mm).
4. Nut-hex: (.2 - 65 amperes) .190 - 32 UNF-2B .313/.303 across flats, .109 \pm .010 thick. (75 - 100 amperes) .250 - 28 UNF-2B .438 \pm .016 across flats or .250 - 20 UNC-2B .375 \pm .016 across flats. Material: Brass ([ASTM-B121/B121M](#) or equivalent); tin plated ([ASTM-B545](#) or equivalent); or Stainless steel, for each terminal.
5. Captive washer nut assembly of brass nut, bronze washer, tin plated; or lockwasher, internal or external tooth, [NASM35333-107](#) or [MS35335-88](#) (.2 - 65 amperes), [NASM35333-108](#) or [MS35335-89](#) (75 -100 amperes) or equivalent. (Use of washers optional on 65 - 100 amperes units.)
6. Washer, flat: (.2 - 50 amperes) .378/.368 O.D., .204/.190 I.D., .032 \pm .005 thick. (65 - 100 amperes) .500 \pm .016 O.D., .281 \pm .016 I.D., .035 \pm .005 thick. Material: Brass ([ASTM-B121/B121M](#) or equivalent), tin plated ([ASTM-B545](#) or equivalent), or phosphor bronze, composition ([ASTM-B139/B139M](#) or equivalent).
7. Lockwasher, Split: (.2 - 65 amperes) [NASM35338-138](#) or equivalent. (75 - 100 amperes) [NASM35338-139](#) or equivalent.
8. Physical item marking of load terminal optional.
9. For configuration 2, an "L" has been added to the end of the dash number.

FIGURE 2. Dimensions and configurations (configuration 2) - Continued.

REQUIREMENTS

Dimensions and configuration: See figures 1 and 2.

Current ratings: See tables I and II.

Voltage ratings: See table III through table VIII. 240 V ac breakers are designed also for use at 120 V ac.

High inrush: Applicable to time delays K, L, M, N, P, R, S, and T. Non-time delays H, I, and J are not high inrush delays.

Tripping-time delays: See table III through table VIII.

Terminal and mounting hardware: See figures 1 and 2.

Terminals: See figures 1 and 2.

Actuator strength: 25 pounds.

Actuator operating force: 4 pounds, maximum.

Endurance (65 through 100 amperes): 6,000 mechanically performed make and break operations.

Terminal strength:

Applied load: 30 pounds.

Applied torque: 22 inch-pounds.

Vibration: Energized current shall be 90 percent for characteristics H, I, and J.

Shock: Energized current shall be 90 percent for characteristics H, I, and J.

Moisture resistance (65 through 100 amperes): Change in resistance shall not exceed 50 percent.

Temperature rise (65 through 100 amperes): 65°C.

Interrupting capacities:

2,000 amperes at 50 V dc (32 V dc for 65 through 100 amperes).

2,000 amperes at 120 V ac, 60 Hz.

1,500 amperes at 120 V ac, 400 Hz.

1,000 amperes at 240 V ac, 60 and 400 Hz.

Part or Identifying Number (PIN): M55629/1- (dash number from table I).

MIL-PRF-55629/1G

TABLE I. Circuit breaker dash numbers and applicable characteristics (configuration 1).

Dash no.	Current rating (amperes)	Voltage frequency and tripping time delay code letter (see tables III, IV, V and VIII)	Resistance or impedance ohms (max.)	Dash no.	Current rating (amperes)	Voltage frequency and tripping time delay code letter (see tables III, IV, V and VIII)	Resistance or impedance ohms (max.)
001	0.2	A	32	271	0.5	P	12
002	0.2	B	32	272	0.5	R	12
003	0.2	C	34	273	0.5	S	12
004	0.2	D	34	436	0.5	T	6
005	0.2	E	72	152	0.75	A	3
006	0.2	F	72	153	0.75	B	3
007	0.2	G	72	155	0.75	C	3
136	0.2	H	32	156	0.75	D	3
137	0.2	I	34	158	0.75	E	7
138	0.2	J	72	159	0.75	F	7
253	0.2	K	32	160	0.75	G	7
254	0.2	L	32	154	0.75	H	3
255	0.2	M	34	157	0.75	I	3
256	0.2	N	34	161	0.75	J	7
257	0.2	P	72	274	0.75	K	3
258	0.2	R	72	275	0.75	L	3
259	0.2	S	72	276	0.75	M	3
434	0.2	T	34	277	0.75	N	3
139	0.25	A	21	278	0.75	P	7
140	0.25	B	21	279	0.75	R	7
142	0.25	C	23	280	0.75	S	7
143	0.25	D	23	437	0.75	T	3
145	0.25	E	43	015	1.0	A	2
146	0.25	F	43	016	1.0	B	2
147	0.25	G	43	017	1.0	C	2
141	0.25	H	21	018	1.0	D	2
144	0.25	I	23	019	1.0	E	4
148	0.25	J	43	020	1.0	F	4
260	0.25	K	21	021	1.0	G	4
261	0.25	L	21	162	1.0	H	2
262	0.25	M	23	163	1.0	I	2
263	0.25	N	23	164	1.0	J	4
264	0.25	P	43	281	1.0	K	2
265	0.25	R	43	282	1.0	L	2
266	0.25	S	43	283	1.0	M	2
435	0.25	T	23	284	1.0	N	2
008	0.5	A	6	285	1.0	P	4
009	0.5	B	6	286	1.0	R	4
010	0.5	C	6	287	1.0	S	4
011	0.5	D	6	438	1.0	T	2
012	0.5	E	12	165	1.5	A	.9
013	0.5	F	12	166	1.5	B	.9
014	0.5	G	12	168	1.5	C	.9
149	0.5	H	6	169	1.5	D	.9
150	0.5	I	6	171	1.5	E	2
151	0.5	J	12	172	1.5	F	2
267	0.5	K	6	173	1.5	G	2
268	0.5	L	6	167	1.5	H	.9
269	0.5	M	6	170	1.5	I	.9
270	0.5	N	6	174	1.5	J	2

MIL-PRF-55629/1G

TABLE I. Circuit breaker dash numbers and applicable characteristics (configuration 1) - Continued.

Dash no.	Current rating (amperes)	Voltage frequency and tripping time delay code letter (see tables III, IV, V and VIII)	Resistance or impedance ohms (max.-)	Dash no.	Current rating (amperes)	Voltage frequency and tripping time delay code letter (see tables III, IV, V and VIII)	Resistance or impedance ohms (max.)
288	1.5	K	.9	035	3.0	G	.5
289	1.5	L	.9	188	3.0	H	.3
290	1.5	M	.9	189	3.0	I	.3
291	1.5	N	.9	190	3.0	J	.5
292	1.5	P	2	309	3.0	K	.3
293	1.5	R	2	310	3.0	L	.3
294	1.5	S	2	311	3.0	M	.3
439	1.5	T	.9	312	3.0	N	.3
022	2.0	A	.5	313	3.0	P	.5
023	2.0	B	.5	314	3.0	R	.5
024	2.0	C	.5	315	3.0	S	.5
025	2.0	D	.5	442	3.0	T	.3
026	2.0	E	.8	191	3.5	A	.15
027	2.0	F	.8	192	3.5	B	.15
028	2.0	G	.8	194	3.5	C	.15
175	2.0	H	.5	195	3.5	D	.15
176	2.0	I	.5	197	3.5	E	.35
177	2.0	J	.8	198	3.5	F	.35
295	2.0	K	.5	199	3.5	G	.35
296	2.0	L	.5	193	3.5	H	.15
297	2.0	M	.5	196	3.5	I	.15
298	2.0	N	.5	200	3.5	J	.35
299	2.0	P	.8	316	3.5	K	.15
300	2.0	R	.8	317	3.5	L	.15
301	2.0	S	.8	318	3.5	M	.15
440	2.0	T	.5	319	3.5	N	.15
178	2.5	A	.35	320	3.5	P	.35
179	2.5	B	.35	321	3.5	R	.35
181	2.5	C	.35	322	3.5	S	.35
182	2.5	D	.35	443	3.5	T	.15
184	2.5	E	.6	036	4.0	A	.1
185	2.5	F	.6	037	4.0	B	.1
186	2.5	G	.6	038	4.0	C	.1
180	2.5	H	.35	039	4.0	D	.1
183	2.5	I	.35	040	4.0	E	.3
187	2.5	J	.6	041	4.0	F	.3
302	2.5	K	.35	042	4.0	G	.3
303	2.5	L	.35	201	4.0	H	.1
304	2.5	M	.35	202	4.0	I	.1
305	2.5	N	.35	203	4.0	J	.3
306	2.5	P	.6	323	4.0	K	.1
307	2.5	R	.6	324	4.0	L	.1
308	2.5	S	.6	325	4.0	M	.1
441	2.5	T	.35	326	4.0	N	.1
029	3.0	A	.3	327	4.0	P	.3
030	3.0	B	.3	328	4.0	R	.3
031	3.0	C	.3	329	4.0	S	.3
032	3.0	D	.3	444	4.0	T	.1
033	3.0	E	.5	043	5.0	A	.08
034	3.0	F	.5	044	5.0	B	.08

MIL-PRF-55629/1G

TABLE I. Circuit breaker dash numbers and applicable characteristics (configuration 1) - Continued.

Dash no.	Current rating (amperes)	Voltage frequency and tripping time delay code letter (see tables III, IV, V and VIII)	Resistance or impedance ohms (max.)	Dash no.	Current rating (amperes)	Voltage frequency and tripping time delay code letter (see tables III, IV, V and VIII)	Resistance or impedance ohms (max.)
045	5.0	C	.08	350	7.0	S	.07
046	5.0	D	.08	447	7.0	T	.04
047	5.0	E	.15	064	8.0	A	.03
048	5.0	F	.15	065	8.0	B	.03
049	5.0	G	.15	066	8.0	C	.03
204	5.0	H	.08	067	8.0	D	.03
205	5.0	I	.08	068	8.0	E	.06
206	5.0	J	.15	069	8.0	F	.06
330	5.0	K	.08	070	8.0	G	.06
331	5.0	L	.08	213	8.0	H	.03
332	5.0	M	.08	214	8.0	I	.03
333	5.0	N	.08	215	8.0	J	.06
334	5.0	P	.15	351	8.0	K	.03
335	5.0	R	.15	352	8.0	L	.03
336	5.0	S	.15	353	8.0	M	.03
445	5.0	T	.08	354	8.0	N	.03
050	6.0	A	.06	355	8.0	P	.06
051	6.0	B	.06	356	8.0	R	.06
052	6.0	C	.06	357	8.0	S	.06
053	6.0	D	.06	448	8.0	T	.03
054	6.0	E	.08	071	9.0	A	.018
055	6.0	F	.08	072	9.0	B	.018
056	6.0	G	.08	073	9.0	C	.02
207	6.0	H	.06	074	9.0	D	.02
208	6.0	I	.06	075	9.0	E	.05
209	6.0	J	.08	076	9.0	F	.05
337	6.0	K	.06	077	9.0	G	.05
338	6.0	L	.06	216	9.0	H	.02
339	6.0	M	.06	217	9.0	I	.02
340	6.0	N	.06	218	9.0	J	.05
341	6.0	P	.08	358	9.0	K	.018
342	6.0	R	.08	359	9.0	L	.018
343	6.0	S	.08	360	9.0	M	.02
446	6.0	T	.06	361	9.0	N	.02
057	7.0	A	.04	362	9.0	P	.05
058	7.0	B	.04	363	9.0	R	.05
059	7.0	C	.04	364	9.0	S	.05
060	7.0	D	.04	449	9.0	T	.02
061	7.0	E	.07	078	10.0	A	.02
062	7.0	F	.07	079	10.0	B	.02
063	7.0	G	.07	080	10.0	C	.02
210	7.0	H	.04	081	10.0	D	.02
211	7.0	I	.04	082	10.0	E	.04
212	7.0	J	.07	083	10.0	F	.04
344	7.0	K	.04	084	10.0	G	.04
345	7.0	L	.04	219	10.0	H	.02
346	7.0	M	.04	220	10.0	I	.02
347	7.0	N	.04	221	10.0	J	.04
348	7.0	P	.07	365	10.0	K	.02
349	7.0	R	.07	366	10.0	L	.02

MIL-PRF-55629/1G

TABLE I. Circuit breaker dash numbers and applicable characteristics (configuration 1) - Continued.

Dash no.	Current rating (amperes)	Voltage frequency and tripping time delay code letter (see tables III, IV, V and VIII)	Resistance or impedance ohms (max.)	Dash no.	Current rating (amperes)	Voltage frequency and tripping time delay code letter (see tables III, IV, V and VIII)	Resistance or impedance ohms (max.)
367	10.0	M	.02	387	20.0	L	.007
368	10.0	N	.02	388	20.0	M	.007
369	10.0	P	.04	389	20.0	N	.007
370	10.0	R	.04	390	20.0	P	.01
371	10.0	S	.04	391	20.0	R	.01
450	10.0	T	.02	392	20.0	S	.01
085	12.5	A	.013	453	20.0	T	.007
086	12.5	B	.013	106	25.0	A	.006
087	12.5	C	.015	107	25.0	B	.006
088	12.5	D	.015	108	25.0	C	.006
089	12.5	E	.03	109	25.0	D	.006
090	12.5	F	.03	110	25.0	E	.007
091	12.5	G	.03	111	25.0	F	.007
222	12.5	H	.013	112	25.0	G	.007
223	12.5	I	.013	231	25.0	H	.006
224	12.5	J	.03	232	25.0	I	.006
372	12.5	K	.013	233	25.0	J	.007
373	12.5	L	.013	393	25.0	K	.006
374	12.5	M	.015	394	25.0	L	.006
375	12.5	N	.015	395	25.0	M	.006
376	12.5	P	.03	396	25.0	N	.006
377	12.5	R	.03	397	25.0	P	.007
378	12.5	S	.03	398	25.0	R	.007
451	12.5	T	.015	399	25.0	S	.007
092	15.0	A	.01	454	25.0	T	.006
093	15.0	B	.01	113	30.0	A	.005
094	15.0	C	.011	114	30.0	B	.005
095	15.0	D	.011	115	30.0	C	.005
096	15.0	E	.02	116	30.0	D	.005
097	15.0	F	.02	117	30.0	E	.006
098	15.0	G	.02	118	30.0	F	.006
225	15.0	H	.013	119	30.0	G	.006
226	15.0	I	.015	234	30.0	H	.005
227	15.0	J	.03	235	30.0	I	.005
379	15.0	K	.01	236	30.0	J	.006
380	15.0	L	.01	400	30.0	K	.005
381	15.0	M	.011	401	30.0	L	.005
382	15.0	N	.011	402	30.0	M	.005
383	15.0	P	.02	403	30.0	N	.005
384	15.0	R	.02	404	30.0	P	.006
385	15.0	S	.02	405	30.0	R	.006
452	15.0	T	.011	406	30.0	S	.006
099	20.0	A	.007	455	30.0	T	.005
100	20.0	B	.007	120	35.0	A	.004
101	20.0	C	.007	121	35.0	B	.004
102	20.0	D	.007	122	35.0	C	.004
103	20.0	E	.01	123	35.0	D	.004
104	20.0	F	.01	124	35.0	E	.005
105	20.0	G	.01	125	35.0	F	.005
228	20.0	H	.007	126	35.0	G	.005
229	20.0	I	.007	237	35.0	H	.004
230	20.0	J	.01	238	35.0	I	.004
386	20.0	K	.007	239	35.0	J	.005

MIL-PRF-55629/1G

TABLE I. Circuit breaker dash numbers and applicable characteristics (configuration 1) - Continued.

Dash no.	Current rating (amperes)	Voltage frequency and tripping time delay code letter (see tables III, IV, V and VIII)	Resistance or impedance ohms (max.)	Dash no.	Current rating (amperes)	Voltage frequency and tripping time delay code letter (see tables III, IV, V and VIII)	Resistance or impedance ohms (max.)
407	35.0	K	.004	127	50.0	A	.003
408	35.0	L	.004	128	50.0	B	.003
409	35.0	M	.004	129	50.0	C	.003
410	35.0	N	.004	130	50.0	D	.003
411	35.0	P	.005	131	50.0	E	.004
412	35.0	R	.005	132	50.0	F	.004
413	35.0	S	.005	133	50.0	G	.004
456	35.0	T	.004	250	50.0	H	.003
240	40.0	A	.0038	251	50.0	I	.003
241	40.0	B	.0038	252	50.0	J	.004
243	40.0	C	.0038	421	50.0	K	.003
244	40.0	D	.0038	422	50.0	L	.003
246	40.0	E	.0052	423	50.0	M	.003
247	40.0	F	.0052	424	50.0	N	.003
248	40.0	G	.0052	425	50.0	P	.004
242	40.0	H	.0038	426	50.0	R	.004
245	40.0	I	.0038	427	50.0	S	.004
249	40.0	J	.0052	458	50.0	T	.003
414	40.0	K	.0038	428	65	A	.003
415	40.0	L	.0038	429	65	B	.003
416	40.0	M	.0038	430	75	A	.0025
417	40.0	N	.0038	431	75	B	.0025
418	40.0	P	.0052	432	85	A	.0025
419	40.0	R	.0052	433	85	B	.0025
420	40.0	S	.0052	134	100	A	.002
457	40.0	T	.0038	135	100	B	.002

MIL-PRF-55629/1G

TABLE II. Circuit breaker dash numbers and applicable characteristics (configuration 2).

Dash no.	Current rating (amperes)	Voltage frequency and tripping time delay code letter (see tables VI, VII and VIII)	Resistance or impedance ohms (max.)	Dash no.	Current rating (amperes)	Voltage frequency and tripping time delay code letter (see tables VI, VII and VIII)	Resistance or impedance ohms (max.)
001L	0.2	A	52	271L	0.5	P	24
002L	0.2	B	52	272L	0.5	R	24
003L	0.2	C	32	273L	0.5	S	24
004L	0.2	D	34	436L	0.5	T	6
005L	0.2	E	88	152L	0.75	A	3
006L	0.2	F	88	153L	0.75	B	3
007L	0.2	G	88	155L	0.75	C	3
136L	0.2	H	52	156L	0.75	D	3
137L	0.2	I	34	158L	0.75	E	7
138L	0.2	J	88	159L	0.75	F	7
253L	0.2	K	52	160L	0.75	G	7
254L	0.2	L	52	154L	0.75	H	3
255L	0.2	M	32	157L	0.75	I	3
256L	0.2	N	34	161L	0.75	J	7
257L	0.2	P	88	274L	0.75	K	3
258L	0.2	R	88	275L	0.75	L	3
259L	0.2	S	88	276L	0.75	M	3
434L	0.2	T	34	277L	0.75	N	3
139L	0.25	A	26	278L	0.75	P	7
140L	0.25	B	26	279L	0.75	R	7
142L	0.25	C	23	280L	0.75	S	7
143L	0.25	D	23	437L	0.75	T	3
145L	0.25	E	43	015L	1.0	A	2
146L	0.25	F	43	016L	1.0	B	2
147L	0.25	G	43	017L	1.0	C	2
141L	0.25	H	26	018L	1.0	D	2
144L	0.25	I	23	019L	1.0	E	4
148L	0.25	J	43	020L	1.0	F	4
260L	0.25	K	26	021L	1.0	G	4
261L	0.25	L	26	162L	1.0	H	2
262L	0.25	M	23	163L	1.0	I	2
263L	0.25	N	23	164L	1.0	J	4
264L	0.25	P	43	281L	1.0	K	2
265L	0.25	R	43	282L	1.0	L	2
266L	0.25	S	43	283L	1.0	M	2
435L	0.25	T	23	284L	1.0	N	2
008L	0.5	A	7	285L	1.0	P	4
009L	0.5	B	7	286L	1.0	R	4
010L	0.5	C	6	287L	1.0	S	4
011L	0.5	D	6	438L	1.0	T	2
012L	0.5	E	24	165L	1.5	A	0.9
013L	0.5	F	24	166L	1.5	B	0.9
014L	0.5	G	24	168L	1.5	C	0.9
149L	0.5	H	7	169L	1.5	D	0.9
150L	0.5	I	6	171L	1.5	E	2.0
151L	0.5	J	24	172L	1.5	F	2.0
267L	0.5	K	7	173L	1.5	G	2.0
268L	0.5	L	7	167L	1.5	H	0.9
269L	0.5	M	6	170L	1.5	I	0.9
270L	0.5	N	8	174L	1.5	J	2.0

MIL-PRF-55629/1G

TABLE II. Circuit breaker dash numbers and applicable characteristics (configuration 2) - Continued.

Dash no.	Current rating (amperes)	Voltage frequency and tripping time delay code letter (see tables VI, VII and VIII)	Resistance or impedance ohms (max.)	Dash no.	Current rating (amperes)	Voltage frequency and tripping time delay code letter (see tables VI, VII and VIII)	Resistance or impedance ohms (max.)
288L	1.5	K	0.9	035L	3.0	G	0.5
289L	1.5	L	0.9	188L	3.0	H	0.3
290L	1.5	M	0.9	189L	3.0	I	0.3
291L	1.5	N	0.9	190L	3.0	J	0.5
292L	1.5	P	2.0	309L	3.0	K	0.3
293L	1.5	R	2.0	310L	3.0	L	0.3
294L	1.5	S	2.0	311L	3.0	M	0.3
439L	1.5	T	0.9	312L	3.0	N	0.3
022L	2.0	A	0.5	313L	3.0	P	0.5
023L	2.0	B	0.5	314L	3.0	R	0.5
024L	2.0	C	0.5	315L	3.0	S	0.5
025L	2.0	D	0.5	442L	3.0	T	0.3
026L	2.0	E	0.9	191L	3.5	A	0.15
027L	2.0	F	0.9	192L	3.5	B	0.15
028L	2.0	G	0.9	194L	3.5	C	0.15
175L	2.0	H	0.5	195L	3.5	D	0.15
176L	2.0	I	0.5	197L	3.5	E	0.35
177L	2.0	J	0.9	198L	3.5	F	0.35
295L	2.0	K	0.5	199L	3.5	G	0.35
296L	2.0	L	0.5	193L	3.5	H	0.15
297L	2.0	M	0.5	196L	3.5	I	0.15
298L	2.0	N	0.5	200L	3.5	J	0.35
299L	2.0	P	0.9	316L	3.5	K	0.15
300L	2.0	R	0.9	317L	3.5	L	0.15
301L	2.0	S	0.9	318L	3.5	M	0.15
440L	2.0	T	5.0	319L	3.5	N	0.15
178L	2.5	A	0.35	320L	3.5	P	0.35
179L	2.5	B	0.35	321L	3.5	R	0.35
181L	2.5	C	0.35	322L	3.5	S	0.35
182L	2.5	D	0.35	443L	3.5	T	0.15
184L	2.5	E	0.60	036L	4.0	A	0.1
185L	2.5	F	0.60	037L	4.0	B	0.1
186L	2.5	G	0.60	038L	4.0	C	0.1
180L	2.5	H	0.35	039L	4.0	D	0.1
183L	2.5	I	0.35	040L	4.0	E	0.3
187L	2.5	J	0.60	041L	4.0	F	0.3
302L	2.5	K	0.35	042L	4.0	G	0.3
303L	2.5	L	0.35	201L	4.0	H	0.1
304L	2.5	M	0.35	202L	4.0	I	0.1
305L	2.5	N	0.35	203L	4.0	J	0.3
306L	2.5	P	0.60	323L	4.0	K	0.1
307L	2.5	R	0.60	324L	4.0	L	0.1
308L	2.5	S	0.60	325L	4.0	M	0.1
441L	2.5	T	0.35	326L	4.0	N	0.1
029L	3.0	A	0.3	327L	4.0	P	0.3
030L	3.0	B	0.3	328L	4.0	R	0.3
031L	3.0	C	0.3	329L	4.0	S	0.3
032L	3.0	D	0.3	444L	4.0	T	0.1
033L	3.0	E	0.5	043L	5.0	A	0.08
034L	3.0	F	0.5	044L	5.0	B	0.08

MIL-PRF-55629/1G

TABLE II. Circuit breaker dash numbers and applicable characteristics (configuration 2) - Continued.

Dash no.	Current rating (amperes)	Voltage frequency and tripping time delay code letter (see tables VI, VII and VIII)	Resistance or impedance ohms (max.)	Dash no.	Current rating (amperes)	Voltage frequency and tripping time delay code letter (see tables VI, VII and VIII)	Resistance or impedance ohms (max.)
045L	5.0	C	0.080	350L	7.0	S	0.078
046L	5.0	D	0.080	447L	7.0	T	0.040
047L	5.0	E	0.150	064L	8.0	A	0.030
048L	5.0	F	0.150	065L	8.0	B	0.030
049L	5.0	G	0.150	066L	8.0	C	0.029
204L	5.0	H	0.080	067L	8.0	D	0.029
205L	5.0	I	0.080	068L	8.0	E	0.063
206L	5.0	J	0.150	069L	8.0	F	0.063
330L	5.0	K	0.080	070L	8.0	G	0.063
331L	5.0	L	0.080	213L	8.0	H	0.030
332L	5.0	M	0.080	214L	8.0	I	0.029
333L	5.0	N	0.080	215L	8.0	J	0.063
334L	5.0	P	0.150	351L	8.0	K	0.030
335L	5.0	R	0.150	352L	8.0	L	0.030
336L	5.0	S	0.150	353L	8.0	M	0.029
445L	5.0	T	0.080	354L	8.0	N	0.029
050L	6.0	A	0.060	355L	8.0	P	0.063
051L	6.0	B	0.060	356L	8.0	R	0.063
052L	6.0	C	0.060	357L	8.0	S	0.063
053L	6.0	D	0.060	448L	8.0	T	0.029
054L	6.0	E	0.104	071L	9.0	A	0.028
055L	6.0	F	0.104	072L	9.0	B	0.028
056L	6.0	G	0.104	073L	9.0	C	0.025
207L	6.0	H	0.060	074L	9.0	D	0.025
208L	6.0	I	0.060	075L	9.0	E	0.050
209L	6.0	J	0.104	076L	9.0	F	0.050
337L	6.0	K	0.060	077L	9.0	G	0.050
338L	6.0	L	0.060	216L	9.0	H	0.028
339L	6.0	M	0.060	217L	9.0	I	0.025
340L	6.0	N	0.060	218L	9.0	J	0.050
341L	6.0	P	0.104	358L	9.0	K	0.0288
342L	6.0	R	0.104	359L	9.0	L	0.0288
343L	6.0	S	0.104	360L	9.0	M	0.025
446L	6.0	T	0.060	361L	9.0	N	0.025
057L	7.0	A	0.041	362L	9.0	P	0.050
058L	7.0	B	0.041	363L	9.0	R	0.050
059L	7.0	C	0.040	364L	9.0	S	0.050
060L	7.0	D	0.040	449L	9.0	T	0.025
061L	7.0	E	0.078	078L	10.0	A	0.023
062L	7.0	F	0.078	079L	10.0	B	0.023
063L	7.0	G	0.078	080L	10.0	C	0.02
210L	7.0	H	0.041	081L	10.0	D	0.02
211L	7.0	I	0.040	082L	10.0	E	0.04
212L	7.0	J	0.078	083L	10.0	F	0.04
344L	7.0	K	0.041	084L	10.0	G	0.04
345L	7.0	L	0.041	219L	10.0	H	0.023
346L	7.0	M	0.040	220L	10.0	I	0.019
347L	7.0	N	0.040	221L	10.0	J	0.043
348L	7.0	P	0.078	365L	10.0	K	0.023
349L	7.0	R	0.078	366L	10.0	L	0.023

MIL-PRF-55629/1G

TABLE II. Circuit breaker dash numbers and applicable characteristics (configuration 2) - Continued.

Dash no.	Current rating (amperes)	Voltage frequency and tripping time delay code letter (see tables VI, VII and VIII)	Resistance or impedance ohms (max.)	Dash no.	Current rating (amperes)	Voltage frequency and tripping time delay code letter (see tables VI, VII and VIII)	Resistance or impedance ohms (max.)
367L	10.0	M	0.02	387L	20.0	L	0.008
368L	10.0	N	0.02	388L	20.0	M	0.008
369L	10.0	P	0.04	389L	20.0	N	0.008
370L	10.0	R	0.04	390L	20.0	P	0.013
371L	10.0	S	0.04	391L	20.0	R	0.013
450L	10.0	T	0.02	392L	20.0	S	0.013
085L	12.5	A	0.015	453L	20.0	T	0.008
086L	12.5	B	0.015	106L	25.0	A	0.006
087L	12.5	C	0.015	107L	25.0	B	0.006
088L	12.5	D	0.015	108L	25.0	C	0.006
089L	12.5	E	0.030	109L	25.0	D	0.006
090L	12.5	F	0.030	110L	25.0	E	0.011
091L	12.5	G	0.030	111L	25.0	F	0.011
222L	12.5	H	0.015	112L	25.0	G	0.011
223L	12.5	I	0.013	231L	25.0	H	0.006
224L	12.5	J	0.030	232L	25.0	I	0.006
372L	12.5	K	0.015	233L	25.0	J	0.011
373L	12.5	L	0.015	393L	25.0	K	0.006
374L	12.5	M	0.015	394L	25.0	L	0.006
375L	12.5	N	0.015	395L	25.0	M	0.006
376L	12.5	P	0.030	396L	25.0	N	0.006
377L	12.5	R	0.030	397L	25.0	P	0.011
378L	12.5	S	0.030	398L	25.0	R	0.011
451L	12.5	T	0.015	399L	25.0	S	0.011
092L	15.0	A	0.010	454L	25.0	T	0.006
093L	15.0	B	0.010	113L	30.0	A	0.005
094L	15.0	C	0.011	114L	30.0	B	0.005
095L	15.0	D	0.011	115L	30.0	C	0.006
096L	15.0	E	0.020	116L	30.0	D	0.006
097L	15.0	F	0.020	117L	30.0	E	0.009
098L	15.0	G	0.020	118L	30.0	F	0.009
225L	15.0	H	0.013	119L	30.0	G	0.009
226L	15.0	I	0.015	234L	30.0	H	0.005
227L	15.0	J	0.030	235L	30.0	I	0.006
379L	15.0	K	0.010	236L	30.0	J	0.009
380L	15.0	L	0.010	400L	30.0	K	0.005
381L	15.0	M	0.011	401L	30.0	L	0.005
382L	15.0	N	0.011	402L	30.0	M	0.006
383L	15.0	P	0.020	403L	30.0	N	0.006
384L	15.0	R	0.020	404L	30.0	P	0.009
385L	15.0	S	0.020	405L	30.0	R	0.009
452L	15.0	T	0.011	406L	30.0	S	0.009
099L	20.0	A	0.008	455L	30.0	T	0.006
100L	20.0	B	0.008	120L	35.0	A	0.004
101L	20.0	C	0.008	121L	35.0	B	0.004
102L	20.0	D	0.008	122L	35.0	C	0.005
103L	20.0	E	0.013	123L	35.0	D	0.005
104L	20.0	F	0.013	124L	35.0	E	0.006
105L	20.0	G	0.013	125L	35.0	F	0.006
228L	20.0	H	0.008	126L	35.0	G	0.006
229L	20.0	I	0.008	237L	35.0	H	0.004
230L	20.0	J	0.013	238L	35.0	I	0.005
386L	20.0	K	0.008	239L	35.0	J	0.006

MIL-PRF-55629/1G

TABLE II. Circuit breaker dash numbers and applicable characteristics (configuration 2) - Continued.

Dash no.	Current rating (amperes)	Voltage frequency and tripping time delay code letter (see tables VI, VII and VIII)	Resistance or impedance ohms (max.)	Dash no.	Current rating (amperes)	Voltage frequency and tripping time delay code letter (see tables VI, VII and VIII)	Resistance or impedance ohms (max.)
407L	35.0	K	0.004	127L	50.0	A	0.003
408L	35.0	L	0.004	128L	50.0	B	0.003
409L	35.0	M	0.005	129L	50.0	C	0.003
410L	35.0	N	0.005	130L	50.0	D	0.003
411L	35.0	P	0.006	131L	50.0	E	0.004
412L	35.0	R	0.006	132L	50.0	F	0.004
413L	35.0	S	0.006	133L	50.0	G	0.004
456L	35.0	T	0.005	250L	50.0	H	0.003
240L	40.0	A	0.0038	251L	50.0	I	0.003
241L	40.0	B	0.0038	252L	50.0	J	0.004
243L	40.0	C	0.0045	421L	50.0	K	0.003
244L	40.0	D	0.0045	422L	50.0	L	0.003
246L	40.0	E	0.0052	423L	50.0	M	0.003
247L	40.0	F	0.0052	424L	50.0	N	0.003
248L	40.0	G	0.0052	425L	50.0	P	0.004
242L	40.0	H	0.0038	426L	50.0	R	0.004
245L	40.0	I	0.0045	427L	50.0	S	0.004
249L	40.0	J	0.0052	458L	50.0	T	0.003
414L	40.0	K	0.0038	428L	65	K	0.002
415L	40.0	L	0.0038	429L	65	L	.003
416L	40.0	M	0.0045	430L	75	K	0.0025
417L	40.0	N	0.0045	431L	75	L	0.0025
418L	40.0	P	0.0052	432L	85	K	0.0025
419L	40.0	R	0.0052	433L	85	L	0.0025
420L	40.0	S	0.0052	134L	100	K	0.002
457L	40.0	T	0.0045	135L	100	L	0.002

TABLE III. Tripping-time delay (configuration 1). 1/ 2/

Time delay percent rated current	Tripping-time delay at 25°C ±2°C (tripping time in seconds)													
	50 V dc				240 V ac, 60 Hz				240 V ac, 400 Hz					
	A		B		C		D		E		F		G	
	Max	Min	Max	Min	Max	Min	Max	Min	Max	Min	Max	Min	Max	Min
100	no trip one hour		no trip one hour		no trip one hour		no trip one hour		no trip one hour		no trip one hour		no trip one hour	
125	70	7	7	.5	120	10	17	.7	N/A	N/A	N/A	N/A	N/A	N/A
150	N/A	N/A	N/A	N/A	N/A	N/A	N/A	N/A	60	5	5.8	.50	400	40
200	8	.6	1.4	.13	20	2.2	1.6	.13	20	2.1	1.9	.15	150	9.5
400	1.5	.15	.25	.031	2.3	.3	.25	.03	3.2	.4	.19	.02	19	1.9
600	.05	Inst	.12	Inst	.75	Inst	.13	Inst	.19	Inst	.08	Inst	1.6	Inst
800	.051	Inst	.051	Inst	.16	Inst	.07	Inst	.06	Inst	.05	Inst	.06	Inst
1,000	.026	Inst	.026	Inst	.04	Inst	.04	Inst	.045	Inst	.036	Inst	.043	Inst

See footnotes at end of table VIII.

TABLE IV. Tripping-time, high-inrush design (configuration 1). 1/3/

Time delay percent rated current	Tripping-time delay at 25°C ±2°C (tripping time in seconds)															
	50 V dc				240 V ac, 60 Hz						240 V ac, 400 Hz					
	K		L		M		N		T		P		R		S	
	Max	Min	Max	Min	Max	Min	Max	Min	Max	Min	Max	Min	Max	Min	Max	Min
100	no trip one hour		no trip one hour		no trip one hour		no trip one hour		no trip one hour		no trip one hour		no trip one hour		no trip one hour	
125	100	10	12	.5	120	10	18	1	700	50	N/A	N/A	N/A	N/A	N/A	N/A
150	N/A	N/A	N/A	N/A	N/A	N/A	N/A	N/A	350	32	60	6	5.8	.6	500	60
200	20	2.5	1.5	.13	20	3	1.6	.16	70	10	20	2.1	2	.2	160	20
400	2	.36	.29	.031	2.3	.3	.3	.04	15	1.5	4	.4	.35	.035	19	2
600	1	.13	.15	Inst	1	.13	.17	Inst	7	.7	.6	Inst	.125	Inst	3.5	.250
800	.6	Inst	.06	Inst	.6	Inst	.09	Inst	3	.1	.06	Inst	.05	Inst	.5	.025
1,000	.29	Inst	.05	Inst	.29	Inst	.043	Inst	2	.01	.045	Inst	.036	Inst	.043	Inst
1,800 4/	no trip		no trip		no trip		no trip		no trip		no trip		no trip		no trip	

See footnotes at end of table VIII.

17

MIL-PRF-55629/1G

TABLE V. Tripping-time, standard delay and high-inrush design (configuration 1). 1/ 2/ 3/

Time delay percent rated current	Tripping-time delay at high and low temperature °C (tripping time in seconds) 5/															
	50 V dc				240 V ac, 60 Hz						240 V ac, 400 Hz					
	A and K		B and L		C and M		D and N		T		E and P		F and R		G and S	
	-40° Max	+85° Min	-40° Max	+85° Min	-40° Max	+85° Min	-40° Max	+85° Min	-40° Max	+85° Min	-40° Max	+85° Min	-40° Max	+85° Min	-40° Max	+85° Min
100	no trip one hour		no trip one hour		no trip one hour		no trip one hour		no trip one hour		no trip one hour		no trip one hour		no trip one hour	
125	500	5	100	.1	500	1	100	.1	8000	25	N/A	N/A	N/A	N/A	1500	5
150	N/A	N/A	N/A	N/A	N/A	N/A	N/A	N/A	900	12	500	.5	100	.1	500	.5
200	100	.1	10	0.05	100	.05	10	.05	500	5	100	.1	10	.5	500	.5
400	20	Inst	3	Inst	20	Inst	3	Inst	100	.8	20	Inst	3	Inst	100	Inst
600	5	Inst	1	Inst	5	Inst	1	Inst	40	.1	6	Inst	1	Inst	5	Inst
800	2	Inst	.5	Inst	.5	Inst	.5	Inst	10	.05	.5	Inst	.5	Inst	.5	Inst
1,000	N/A	N/A	N/A	N/A	N/A	N/A	N/A	N/A	3	.01	N/A	N/A	N/A	N/A	N/A	N/A

See footnotes at end of table VIII.

18

MIL-PRF-55629/1G

TABLE VI. Tripping-time, standard delay and high-inrush design (configuration 2). 1/ 2/ 3/

Time delay percent rated current	Tripping-time delay at 25°C ±2°C (tripping time in seconds)															
	50 V dc				240 V ac, 60 Hz						240 V ac, 400 Hz					
	A and K		B and L		C and M		D and N		T		E and P		F and R		G and S	
	Max	Min	Max	Min	Max	Min	Max	Min	Max	Min	Max	Min	Max	Min	Max	Min
100	no trip one hour		no trip one hour		no trip one hour		no trip one hour		no trip one hour		no trip one hour		no trip one hour		no trip one hour	
125	60	7	6.5	0.5	120	10	12	0.7	700	50	N/A	N/A	N/A	N/A	N/A	N/A
150	N/A	N/A	N/A	N/A	N/A	N/A	N/A	N/A	400	30	70	5	8	0.5	400	40
200	10	.6	1.2	0.13	20	2.2	3	0.13	150	10	25	2.1	1.9	0.15	150	9.5
400	2	.15	0.5	0.031	3	0.3	1	0.03	20	1.5	5	0.4	0.4	0.02	19	1.9
600	1	Inst	0.25	Inst	2	Inst	0.3	Inst	10	0.4	2.4	Inst	0.25	Inst	7	Inst
800	0.5	Inst	0.1	Inst	0.8	Inst	0.15	Inst	8	Inst	1	Inst	0.1	Inst	0.4	Inst
1,000	0.1	Inst	Inst	Inst	0.25	Inst	0.1	Inst	6	Inst	0.1	Inst	0.05	Inst	0.043	Inst
1,800 4/	no trip		no trip		no trip		no trip		no trip		no trip		no trip		no trip	

See footnotes at end of table VIII.

19

MIL-PRF-55629/1G

TABLE VII. Tripping-time, high-low temperature standard delay and high-inrush delay (configuration 2). 1/ 2/ 3/

Time delay percent rated current	Tripping-time delay at high and low temperature °C (tripping time in seconds) 5/															
	50 V dc				240 V ac, 60 Hz						240 V ac, 400 Hz					
	A and K		B and L		C and M		D and N		T		E and P		F and R		G and S	
	-40° Max	+85° Min	-40° Max	+85° Min	-40° Max	+85° Min	-40° Max	+85° Min	-40° Max	+85° Min	-40° Max	+85° Min	-40° Max	+85° Min	-40° Max	+85° Min
100	no trip one hour		no trip one hour		no trip one hour		no trip one hour		no trip one hour		no trip one hour		no trip one hour		no trip one hour	
125	500	5	100	0.1	700	1	100	0.1	8000	25	N/A	N/A	N/A	N/A	N/A	N/A
150	N/A	N/A	N/A	N/A	N/A	N/A	N/A	N/A	1600	12	600	0.5	100	0.1	1500	5
200	100	.1	10	0.05	160	0.05	10	0.05	1200	5	130	0.1	10	0.05	500	0.5
400	20	Inst	3	Inst	26	Inst	3	Inst	130	0.8	32	Inst	3	Inst	100	Inst
600	5	Inst	1	Inst	13	Inst	1	Inst	60	0.055	26	Inst	1	Inst	24	Inst
800	2	Inst	0.5	Inst	2.8	Inst	0.5	Inst	28	Inst	8.4	Inst	0.5	Inst	3	Inst
1,000	N/A	N/A	N/A	N/A	N/A	N/A	N/A	N/A	10	Inst	N/A	N/A	N/A	N/A	N/A	N/A

See footnotes at end of table VIII.

20

MIL-PRF-55629/1G

TABLE VIII. Tripping-time, high-inrush nondelay (configuration 1 and 2). 1/ 2/

Time delay percent rated current	Tripping-time delay at $-40^{\circ}\text{C} \pm 2^{\circ}\text{C}$, $+25^{\circ}\text{C} \pm 2^{\circ}\text{C}$, and $+85^{\circ}\text{C} \pm 2^{\circ}\text{C}$ (tripping time in seconds)					
	50 V dc		240 V ac, 60Hz		240 V ac, 400 Hz	
	H (nondelay)		I (nondelay)		J (nondelay)	
	Max	Min	Max	Min	Max	Min
100	no trip one hour		no trip one hour		no trip one hour	
125	0.15	Inst	0.15	Inst	---	---
150	---	---	---	---	0.150	Inst
200	0.07	Inst	0.05	Inst	0.070	Inst
400	0.032	Inst	0.02	Inst	0.032	Inst
600	0.02	Inst	0.017	Inst	0.020	Inst
800	0.02	Inst	0.017	Inst	0.020	Inst

- 1/ Circuit breakers shall not trip at 100 percent rated current. Characteristics A, B, C, D, H, I, K, L, M, and N must trip at 125 percent rated current; E, F, G, J, P, R, and S at 150 percent. Any characteristic may trip between 100 percent and the must-trip value. Instantaneous (Inst) is defined as less than 15 milliseconds.
- 2/ Voltage, frequency, and tripping-time delay codes A, B, C, D, E, F, G, H, I, and J are standard delays without the high-inrush feature.
- 3/ Voltage, frequency, and time delay codes K, L, M, N, P, R, S, and T incorporate the high-inrush or transient suppression feature.
- 4/ High-inrush test shall be performed using one alternation which has a peak value of 1,800 percent of rated current. 400 Hz and dc delays are subjected to a 400 Hz waveform, 60 Hz delays shall be subjected to a 60 Hz waveform.
- 5/ High and low test temperature tolerances are $\pm 2^{\circ}\text{C}$.

MIL-PRF-55629/1G

TABLE IX. Supersession and substitution data.

Circuit breakers covered by this specification sheet are substitutable for the manufacturer's PINs as shown below. This information in no way implies that the manufacturer's PIN is substitutable for the military PIN.

Superseding military PIN	Superseded manufacturers PIN	
M55629/1-XXX	CAGE 81541	CAGE 74193
	Type APL-1 UPL-1 IEL-1	Type AM1
	The complete PIN consists of the type (above) plus identification codes for comparable internal connections, voltage, frequency, time delay and current rating.	

Reference documents. In addition to [MIL-PRF-55629](#), this document references the following:

[ASTM-B121/B121M](#) [ASTM-B139/B139M](#) [ASTM-B545](#) [NASM35333](#)
[MS35335](#) [NASM35338](#)

| The margins of this specification are marked with vertical lines to indicate where changes from the previous issue were made. This was done as a convenience only and the Government assumes no liability whatsoever for any inaccuracies in these notations. Bidders and contractors are cautioned to evaluate the requirements of this document based on the entire content irrespective of the marginal notations and relationship to the last previous issue.

Custodians:
 Army - CR
 Navy - EC
 Air Force - 85
 DLA - CC

Preparing activity:
 Army - CR

Agent:
 DLA - CC

| Review activities:
 Army - AV, CR4, MI
 Navy - AS, MC, OS
 Air Force - 19, 99

(Project 5925-2010-001)

NOTE: The activities listed above were interested in this document as of the date of this document. Since organizations and responsibilities can change, you should verify the currency of the information above using the ASSIST Online database at <https://assist.daps.dla.mil>.