

Automotive High-speed Differential Transmission

CONNECTOR

MX48 Series

MB-0249-2

September 2021

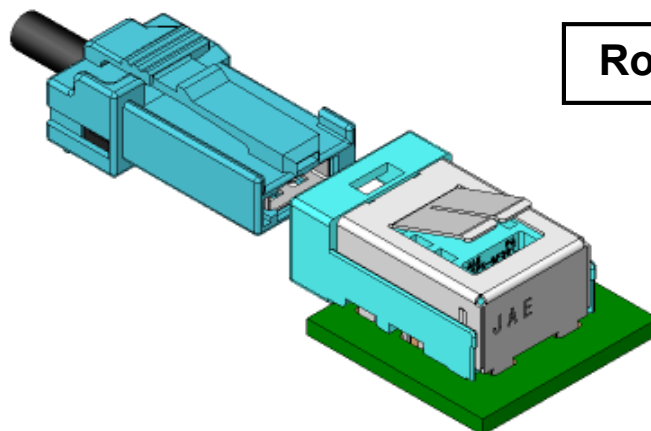

Along with the electro-mechanical advances taking place in cars, the number of parts used is increasing and there is a demand for more compact electrical units.

At the same time, the use of displays is growing due to DVD watching in the back seat, safety checks using a rear monitor, and LCD type instrument panels.

And as the displays become larger and high-definition the signal used is shifting from analog to digital high-speed differential transmission, which can transmit large amounts of data more efficiently.

To meet these demands, JAE has developed the MX48 Series connector for automotive high-speed differential transmission.

The MX48 Series is minimized in depth, height, and width compared to our previous product and achieves a 48% reduction in volume.

It is also compatible with GVIF and LVDS transmission, which are ideal for the transmission of video signals in cars.

* "GVIF" is a trademark of Sony Corporation.

Features

- Achieves a 48% reduction in volume compared to our previous product.
- 2.0mm side pitch, 2-position signal lines.
- Compatible with GVIF and LVDS transmission.
- Impedance matching design, compatible with high-speed transmission.
- Mechanical lock and twist-resistant structure for mated connector.
- Dual-shield structure with ground terminals for EMI control.
- Available as a completed harness to ensure transmission performance reliability.

General Specifications

- No. of Contacts: 2 positions
- Dielectric Withstanding Voltage: AC1000 Vr.m.s. (applied voltage) per minute (mated condition)
- Operating Temperature: -40 Deg. C to +85 Deg. C
- Insulation Resistance: 100M Ω min. (mated condition)
- Applicable Board Thickness: 1.6mm
- Applicable Wire: Shielded twisted pair wire (for harness)
- Connector Insertion Force: 70N max.

Materials and Finishes

■ Angle Pin Connector

Component	Material / Finish
Signal Terminal	Copper Alloy / Contact area: Au plating over Ni Board termination area: Sn plating
External Housing	SPS-GF30
Internal Housing	LCP-GF35
Ground Terminal Shield Shell	Copper Alloy / Sn Plating

■ Socket Connector

Component	Material / Finish
Signal Terminal	Copper Alloy / Contact area: Au plating over Ni Board termination area: Sn plating
External Housing Retainer	PBT
Internal Housing Holder	LCP-GF35
Ground Terminal	Copper Alloy / Sn Plating
Cover Shell Sleeve	Brass / Sn Plating

Angle Pin Connector (MX48002NQ1) Drawing No.: SJ110279

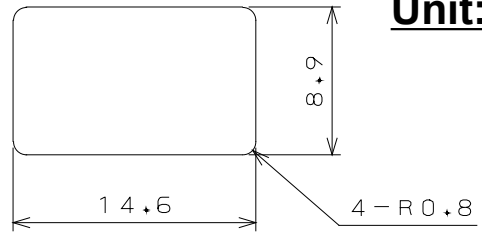
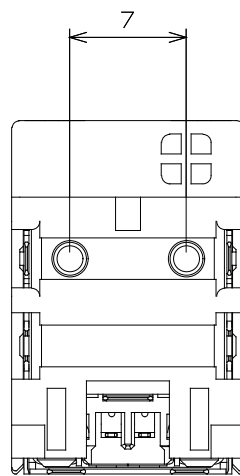
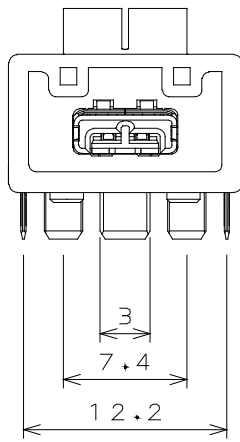
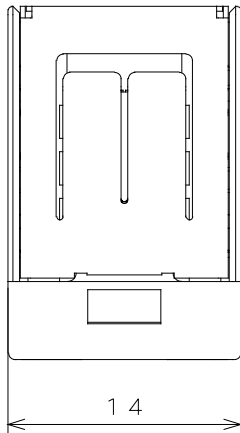

Unit: mm

PANEL CUT OUT DIMENSION (REF.)

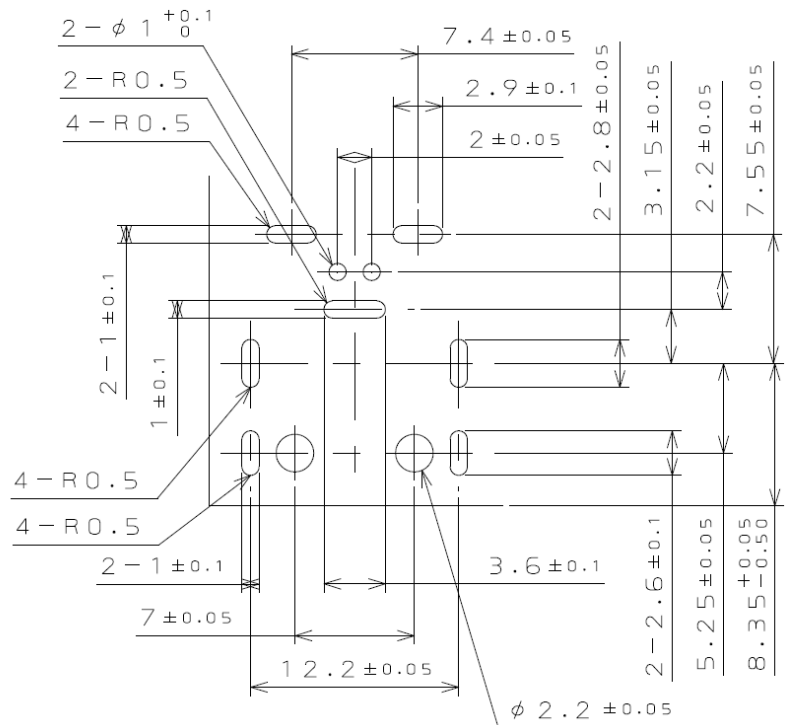
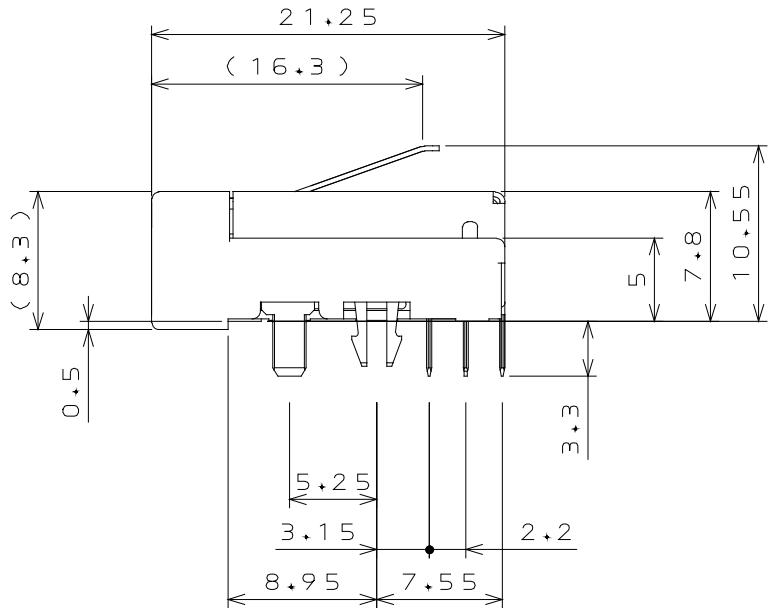

■ Socket Connector (for reference)

Unit: mm

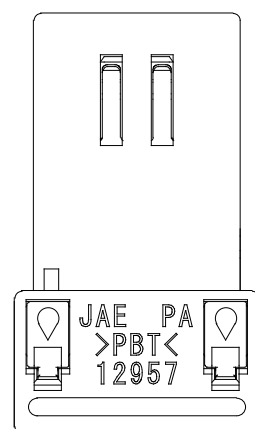
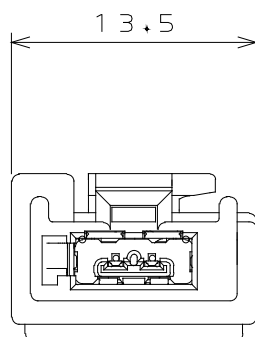
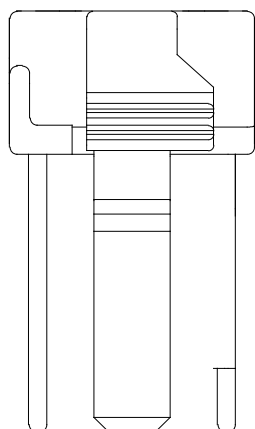

Note:

**Socket connector is a harness product.
It is not sold as an individual connector.**

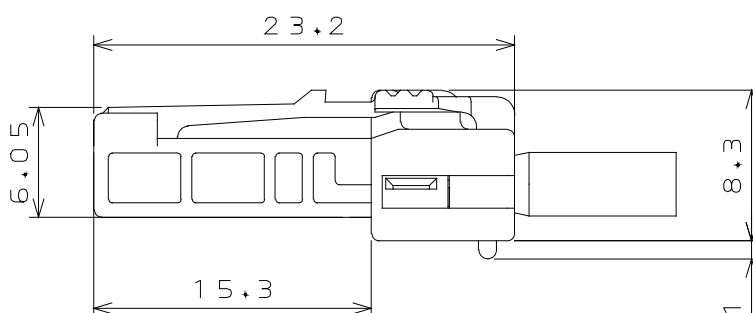

Other

Specifications

JACS-10666

Notice:

- The values specified in this brochure are only for reference. The products and their specifications are subject to change without notice. Contact our sales staff for further information before considering or ordering any of our products.
For purchase, a product specification must be agreed upon.
- Users are requested to provide protection circuits and redundancy circuits to ensure safety of the equipment, and sufficiently review the suitability of JAE's products to the equipment.
- The products presented in this brochure are designed for the uses recommended below.
We strongly suggest you contact our sales staff when considering use of any of the products in any other way than the recommended applications or for a specific use that requires an extremely high reliability.
 - Applications that require consultation:
 - Please contact us if you are considering use involving a quality assurance program that you specify or that is peculiar to the industry, such as:
Automotive electrical components, train control, telecommunications devices (mainline), traffic light control, electric power, combustion control, fire prevention or security systems, disaster prevention equipment, etc.
 - We may separately give you our support with a quality assurance program that you specify, when you think of a use such as :
Aviation or space equipment, submarine repeaters, nuclear power control systems, medical equipment for life support, etc.
 - Recommended applications include:
Computers, office appliances, telecommunications devices (terminals, mobile units), measuring equipment, audiovisual equipment, home electric appliances, factory automation equipment, etc.

Japan Aviation Electronics Industry, Limited

* The specifications in this brochure are subject to change without notice. Please contact JAE for information.