

REVISIONS

P	LTR	DESCRIPTION	DATE	DWN	APVD
A		REVISED PER E.O. P19446	15JAN2007	-	RDR
B		REVISED PER E.O. P20338	5NOV2009	-	RDR
C		REVISED PER PCN-24-222744	18SEP2024	GB	CB
CI		REVISED PER PCN-26-276648	13APR2026	CO	EC

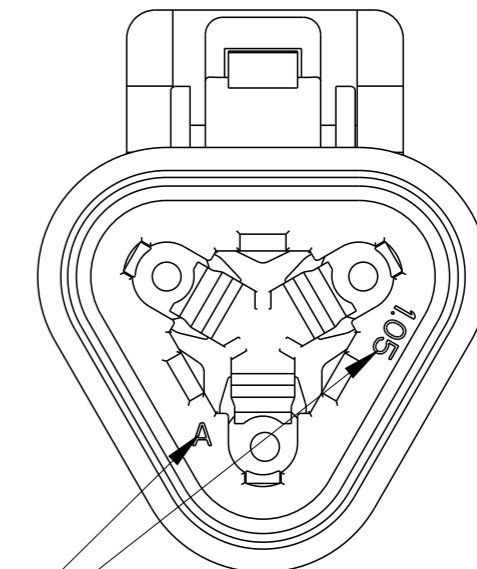

DATE CODE : MONTH REPRESENTED BY SEQUENTIAL ALPHA CHARACTERS.
 EX. A = JANUARY
 YEAR IS REPRESENTED BY LAST NUMERICAL DIGIT
 EX. 0 = 2020

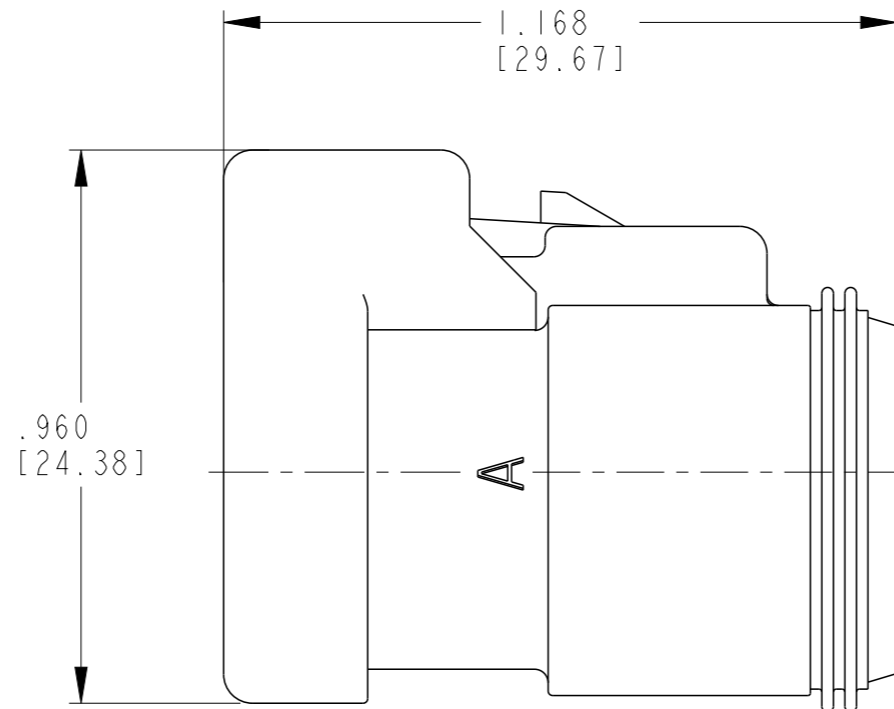
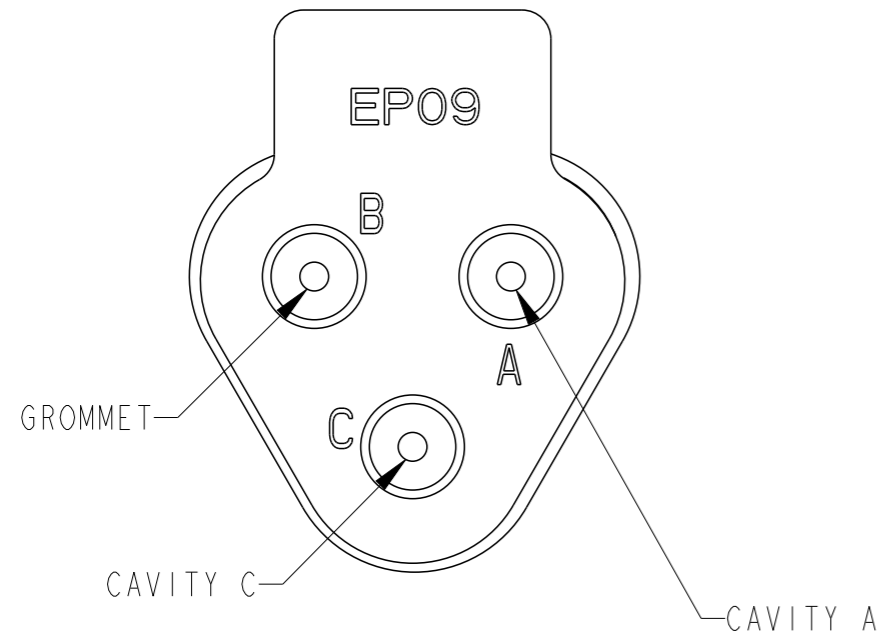
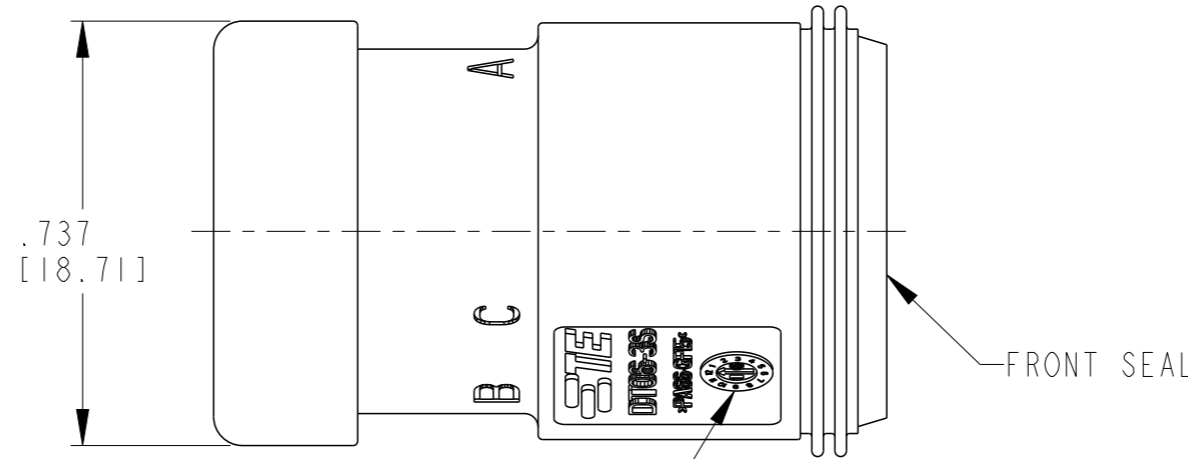
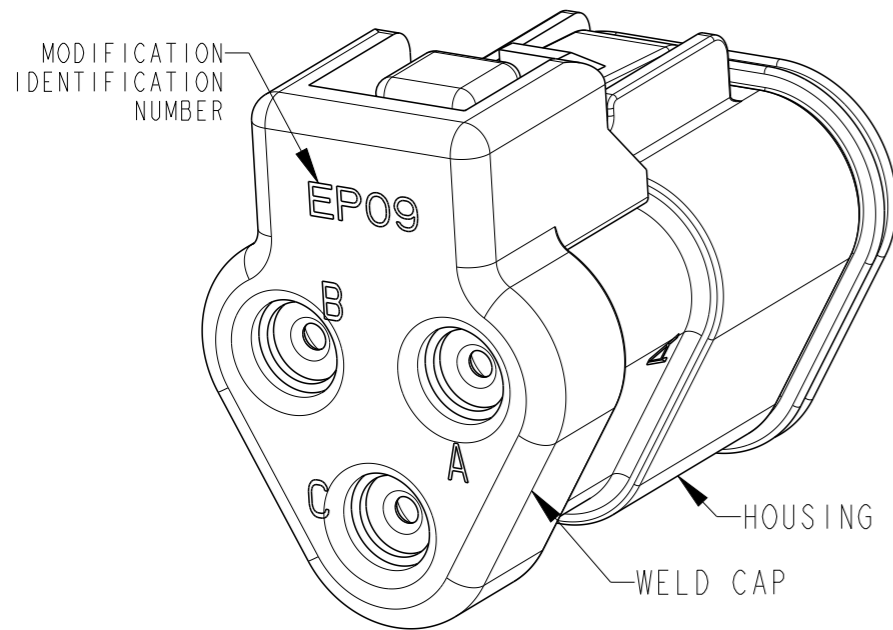

OPTIONAL DATECODE
 GEOMETRY AND LOCATION

3 MATERIAL: HOUSING: PA66 GF15 (BLACK)
 CAP: PA66 GF15 (BLACK)
 FRONT SEAL: VMQ (RED-ORANGE)
 GROMMET: VMQ (RED-ORANGE)

2. THIS PLUG MATES WITH DT04-3P-XXXX RECEPTACLE.
 (XXXX = ALL MODIFICATIONS)
 CONSULT FACTORY FOR MODIFICATION

FOR CONTACTS AND WIRE PERFORMANCE AND APPLICATION CHARACTERISTICS, SEE ENVELOPE DRAWINGS 0425-015-000 AND 0425-017-0000

NOTES:

TE INTERNAL PN		DEUTSCH PN	
DT06-3S-EP09		DT06-3S-EP09	
CONTACT SIZE	MIN. INSUL O.D.	MAX. INSUL O.D.	WIRE RANGE [mm ²] REF. ONLY
16	.088 [2.23]	.145 [3.68]	14-20 AWG [2.5-0.5]

THIS DRAWING IS A CONTROLLED DOCUMENT.		DWN S. THEIS 24NOV1998	TE TE Connectivity			
DIMENSIONS: in [mm]		CHK B. BYFORD 05NOV2009				
TOLERANCES UNLESS OTHERWISE SPECIFIED:		APVD S. BEARD 04NOV2009	NAME 3 WAY PLUG LATCH PROTECTOR CAP DT SERIES			
0 PLC ±		PRODUCT SPEC 108-151009				
1 PLC ±		APPLICATION SPEC 114-151009	SIZE A3	CAGE CODE 4AFU8	DRAWING NO C-DT06-3S-EP09	RESTRICTED TO
2 PLC ±		WEIGHT 7.10g				
3 PLC ±.025 [0.64]						
4 PLC ±						
ANGLES ±°						
MATERIAL 3		CUSTOMER DRAWING				
FINISH		SCALE 3:1		SHEET 1 OF 1		REV CI