

Color: ■ blue

Dimensions in mm

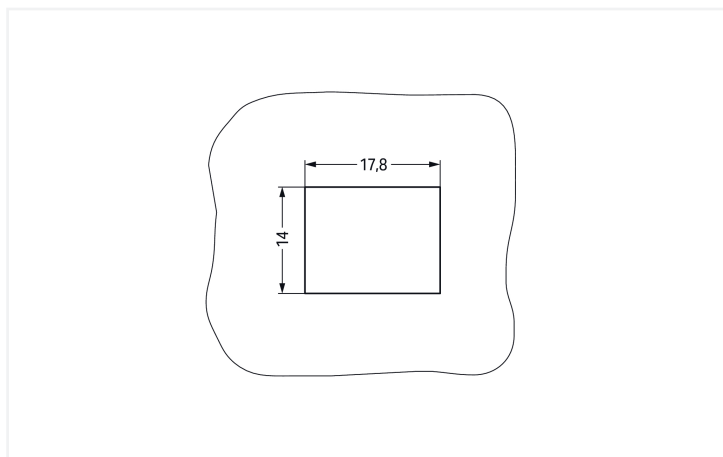

Dimensions in mm

Plate thickness: 0.5 ... 2 mm Cutout tolerance: + 0.1 mm Please note!

Male connector/plug *WINSTA*® MINI rated current 16 A

The *WINSTA*® MINI male connector/plug I coding supports rapid, correct installation. Whether on PCBs, in control cabinets or for connecting lights – pluggable installation connectors from WAGO allow you to establish connections according to many different requirements in seconds. For greater protection in electrical installations, the pluggable installation connector is equipped with mechanical protection against mismatching. Controlled lighting, as implemented in the DALI standard, for example, is the main use of *WINSTA*® MINI pluggable installation connectors with I coding. Especially where space is tight, our smallest pluggable connection system, *WINSTA*® MINI, consistently displays its advantages. It saves space, and, thanks to Push-in CAGE CLAMP® spring pressure connection technology, it additionally can be installed quickly, since the connection is low-maintenance and can be performed without screw connections.

Push-in CAGE CLAMP® spring pressure connection technology – pluggable installation instead of laborious screw connections!

The *WINSTA*® Pluggable Connection System allows pluggable electrical installation. This significantly reduces the need for servicing and lowers costs. Choose durability and quality – with locking lever from WAGO makes the electrical installation of electrical components visibly easier.

- protection against mismatching eliminates errors
- easy tool-free operation, a wide range of coding options
- for intelligent, easy lighting installation
- flexible installation to save space
- convenient installation and commissioning

Notes

General safety information

NOTICE: Observe installation and safety instructions!

- Nur von Elektrofachkraft oder einer für die Tätigkeit elektrisch unterwiesenen Person (EUP nach DIN VDE 0105-100) anzuwenden!
- Nicht unter Spannung/Last installieren!
- Nur für bestimmungsgemäßen Gebrauch einsetzen!
- Nationale Vorschriften/Normen/Richtlinien beachten!
- Technische Daten der Produkte beachten!
- Auf die richtige Polbelegung achten!
- Keine beschädigten/verschmutzten Komponenten verwenden!
- Leiterarten, -querschnitte, Abisolierlängen und Leitungsdurchmesser beachten!
- Leiter bis zum Anschlag einführen!
- Nur mit Verriegelungsklinke und Zugentlastung verwenden!
- Originalzubehör verwenden!

To be sold only with installation instructions!

Note

The snap-in connectors must be relieved of tensile and transverse forces. A surface finish can influence the edge radius of the cutouts. This may affect the snap-in socket fit, so ensure an adequate fit before use. In addition, the punched edge should be on the inside for punched cutouts. The wings of the snap-in connectors must not be mechanically stressed for a long period before use (e.g., due to a pre-locking position).

Electrical data

Ratings per	IEC/EN 60664-1		
	III	III	II
Overvoltage category	III	III	II
Pollution degree	3	2	2
Nominal voltage	250 V	-	-
Rated impulse withstand voltage	4 kV	-	-
Rated current	16 A	-	-

Approvals per

UL 1977

Rated voltage	600 V
Rated current	14 A

General information

Note on contact resistance	approx. 1 mΩ of contact resistance approx. 0.25 mΩ contact transition plug/ socket
----------------------------	--

Connection Data

Clamping units	2
Total number of potentials	2

Connection 1

Connection technology	Push-in CAGE CLAMP®
Actuation type	Operating tool Push-in
Nominal cross-section	1.5 mm ² / 16 AWG
Solid conductor	0.25 ... 1.5 mm ² / 22 ... 16 AWG
Solid conductor; push-in termination	0.75 ... 1.5 mm ² / 20 ... 16 AWG
Stranded conductor	0.25 ... 1 mm ² / 22 ... 18 AWG
Fine-stranded conductor	0.25 ... 1.5 mm ² / 22 ... 16 AWG
Fine-stranded conductor; with insulated ferrule	0.25 ... 0.75 mm ² / 22 ... 20 AWG
Fine-stranded conductor; with uninsulated ferrule	0.25 ... 0.75 mm ² / 22 ... 20 AWG
Fine-stranded conductor; with ferrule; push-in termination	0.75 mm ² / 20 AWG
Strip length	9 mm / 0.35 inches
Pole number	2
Conductor entry direction to mating direction	0°

Physical data

Pin spacing	4.4 mm / 0.173 inches
Width	19.8 mm / 0.78 inches
Height	16 mm / 0.63 inches
Depth	39.85 mm / 1.569 inches

Mechanical data

Use	DALI, Lighting Management
Coding	I
Variable coding	No
Marking	- +
Potential marking	- +
Mating force of a plug-in connection	approx. 20 ... 70 N (depending on pole number)
Retention force of a plug-in connection	Locked: > 80 N
Unmating force of a plug-in connection	Unlocked: approx. 20 ... 70 N (depending on pole number)
Number of mating cycles	200, without resistive load
Housing sheet thickness	0.5 ... 2 mm / 0.02 ... 0.079 inches
Mounting type	Snap-in flange
Protection type	IP20; IP40 when mated
Suitable for through-panel applications	Yes

Plug-in connection

Contact type (pluggable connector)	Male connector/plug
Connector (connection type)	for conductor
Mismating protection	Yes
Note on mismating protection	All <i>WINSTA</i> ® components are 100% protected against mismating when: a.) plugging different numbers of poles b.) plugging while rotated 180 c.) plugging while laterally staggered d.) plugging one pole
Locking lever	Yes
Locking of plug-in connection	Locking lever
Note on locking system	All connectors for mounted installations (snap-in versions for lighting fixtures or devices, all types of PCB and distribution connectors) are factory-equipped with locking levers to ensure plugs and sockets are securely locked. Additional locking levers are only required for flying leads (plug/socket).

Material data

Note (material data)	Information on material specifications can be found here
Color	blue
Cover color	gray
Material group	I
Insulation material (main housing)	Polyamide (PA66)
Flammability class per UL94	V0
Clamping spring material	Chrome-nickel spring steel (CrNi)
Contact material	Copper or copper alloy; surface-treated
Contact Plating	Tin
Fire load	0.126 MJ
Weight	5.2 g

Environmental requirements

Processing temperature	-5 ... +40 °C
Continuous operating temperature	-35 ... +85 °C
Note on continuous operating temperature	Insulating parts for temperatures ≤ 105 °C

Commercial data

Product Group	20 (Winsta)
PU (SPU)	50 (50) pcs
Packaging type	Box
Country of origin	PL
GTIN	4045454548162
Customs tariff number	85366990990

Product Classification

UNSPSC	39121409
eCl@ss 10.0	27-44-06-02
eCl@ss 9.0	27-44-06-02
ETIM 9.0	EC002566
ETIM 10.0	EC002566
ECCN	NO US CLASSIFICATION

Environmental Product Compliance

RoHS Compliance Status	Compliant, No Exemption
------------------------	-------------------------

Approvals / Certificates

General approvals



Approval	Standard	Certificate Name
CCA DEKRA Certification B.V.	EN 61535	71-123231
CCA DEKRA Certification B.V.	IEC 61535	NL-85020
cURus Underwriters Laboratories Inc.	UL 1977	E45171

Declarations of conformity and manufacturer's declarations

Approval	Standard	Certificate Name
EU-Declaration of Confor- mity WAGO GmbH & Co. KG	-	-
UK-Declaration of Confor- mity WAGO GmbH & Co. KG	-	-

Approvals for marine applications



Approval	Standard	Certificate Name
ABS American Bureau of Ship- ping	Steel Vessel Rules	24-0095973-PDA
DNV GL Det Norske Veritas, Ger- manischer Lloyd	-	TAE00001Z6
LR Lloyds Register	EN 61535	08/20047 (E2)
PRS Polski Rejestr Statków	-	TE/1096/880590/23

Downloads

Environmental Product Compliance

Compliance Search

Environmental Product Compliance 890-2112



Documentation

Bid Text

890-2112	19.02.2019	xml 2.91 KB	
890-2112	08.06.2015	doc 22.50 KB	

CAD/CAE-Data

CAD data

2D/3D Models
890-2112



CAE data

EPLAN Data Portal
890-2112



WSCAD Universe
890-2112



ZUKEN Portal
890-2112



1 Compatible Products

1.1 System counterpart

1.1.1 Cable assembly



Item No.: 891-8982/106-101

pre-assembled connecting cable; Eca; Socket/open-ended; 2-pole; Cod. I; H05VV-F 2 x 1.5 mm²; 1 m; 1,50 mm²; blue

Item No.: 891-8982/006-101

pre-assembled interconnecting cable; Eca; Socket/plug; 2-pole; Cod. I; H05VV-F 2 x 1.5 mm²; 1 m; 1,50 mm²; blue

1.1.2 Female connector/socket



Item No.: 890-1102

Socket; 2-pole; Cod. I; 1,50 mm²; blue

1.2 Optional Accessories

1.2.1 Cover

1.2.1.1 Cover



Item No.: 890-642

Lockout cap; 2-pole; for cutouts; Plastic; black

Item No.: 890-692

Lockout cap; 2-pole; for cutouts; Plastic; white

1.2.2 Tool

1.2.2.1 Operating tool



Item No.: 890-382

Operating tool; 2-way; green

Item No.: 210-719

Operating tool; Blade: 2.5 x 0.4 mm; with a partially insulated shaft

Installation Notes

Conductor termination

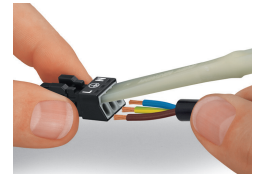
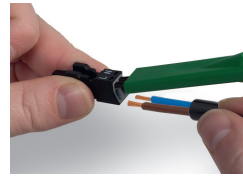
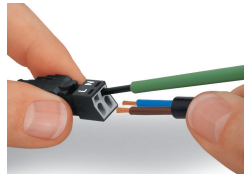
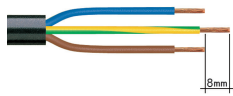

1. Strip length, outer insulation = 30 mm (2-pole), 37 mm (3-pole), 45 mm (4- and 5-pole)
2. Strip length = 9 mm
3. Extended ground conductor = 8 mm

To terminate fine-stranded conductors, open the clamping unit via screwdriver – 2.5 mm blade width – and insert a stripped conductor until it hits the backstop. Terminate solid conductors by simply pushing them in.

To terminate fine-stranded conductors, open clamping units via operating tool (890-382) and insert stripped conductors until they hit backstop. Terminate solid conductors by simply pushing them in.