

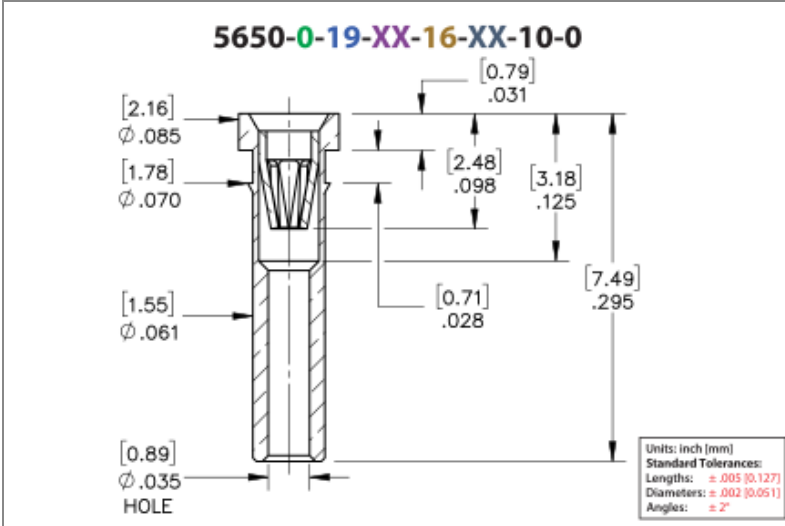

PRODUCT NUMBER: 5650-0-19-01-16-01-10-0

www.mill-max.com
DATA SHEET



5650-0-19-01-16-01-10-0 SPECIFICATIONS

General Info	
Description¹: Receptacle With No Tail	
Mounting Feature:	Press-Fit into a Non-Plated Through Hole (NPTH)
Mounting Hole:	.067" (1,702mm)
Pin Diameter Range:	.022"-.034" (0,559-0,864mm)
Packaging:	Packaged in Bulk
RoHS:	No
Product Lifecycle²:	Active
Country Of Origin:	USA

Materials	
Shell Material³:	Brass Alloy
Shell Plating⁴:	200 - 300 μ" Tin/Lead over Nickel
Contact Plating⁵:	200 - 300 μ" Tin/Lead over Nickel

Technical Specs	
Mechanical life (Durability)⁶:	1,000 Cycles Minimum
Operating Temperature Range⁷:	-55/+125° C
Maximum Current:	16A @ 30° C Temp. Rise
Maximum Derated Current:	12.8A
Contact Resistance:	10 mΩ Max
Shock⁸:	No Elect. Discontinuity > 1μs @ 50g
Vibration⁹:	No Elect. Discontinuity > 1μs @ 10-2000HZ, 20 G

NOTES:

- Standard Tolerances:
Lengths +/- .005" (0,13)
Diameters: +/- .002" (0,051)
Angles: +/- 2°
- Part is Active and in Production, No Scheduled Obsolescence
- Brass Alloy 360 per ASTM B 16, or 385 per ASTM B455
- TIN/LEAD (93/7) per ASTM B 545 (Appendix X6.3.2.5 to eliminate whisker growth) Bright finish; NICKEL per ASTM B 689, Type 2 (Bright)
- TIN/LEAD (93/7) per ASTM B 545 (Appendix X6.3.2.5 to eliminate whisker growth) Bright finish, NICKEL per ASTM B 689, Type 2 (Bright)
- Receptacles are capable of 1,000 Minimum insertion/extraction cycles for a broad range of applications. Mating pin size, shape and finish, along with application specific variables, will affect the life of a receptacle contact.
- Per IEC 60512-11-(4,-9,-10,-12)
- Per IEC 60512-6-3: Test 6c: Shock
- Per IEC 60512-6-4: Test 6d: Vibration (sinusoidal)

CONTACT:

#16 CONTACT

FOR .022"-.034" DIA. & .025" SQ. ($\delta = .006$)
6-FINGER (BeCu), GROUP D

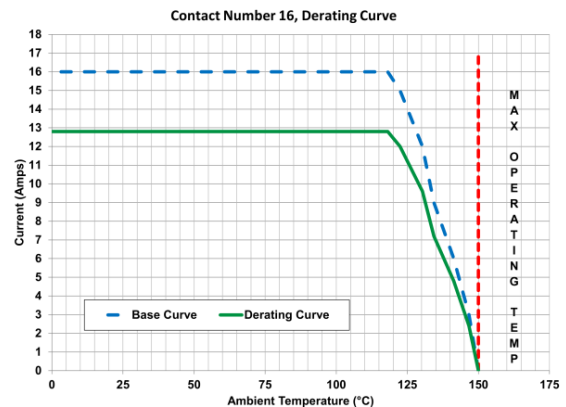
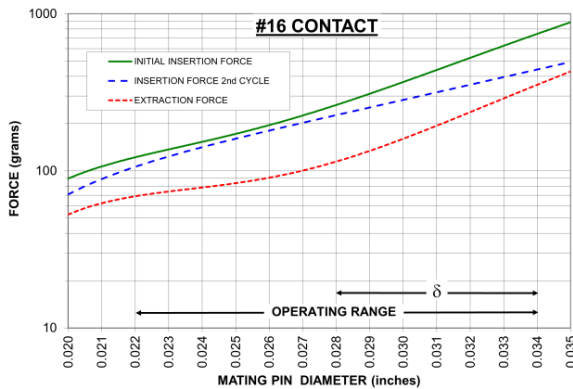
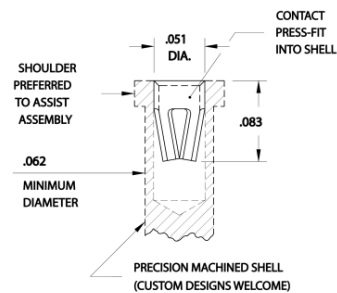

The insertion / extraction force characteristics above were derived using a 30 microinch gold-plated contact and polished steel gauge pins having a bullet-shaped tip. The curves represent typical average values; they are best used to compare the differences between similar size contacts and to guide you in selecting one that is suitable for your application. Your results may vary, so for your specification, we encourage you to obtain complimentary samples for your evaluation.

Material	Beryllium Copper	Fingers	6
Compliance (δ)	0.006	Length	.083" (2,108mm)
Square Post	25.00	Maximum Current	16A @ 30° C Temp. Rise
Maximum Operating Temp @ Max Current	120.00° C	20% De-rated Maximum Current	12.80A

ADDITIONAL NOTES AND SPECIFICATIONS

In the interest of improved design, quality and performance , Mill-Max reserves the right to make changes in its specifications without prior notice. Specifications and tolerances are provided wherever possible. The tolerance on dimensions of critical to function features is typically held tighter than the stated standard tolerances, such as press-fits, holes and lengths affecting the coplanarity of SMT products. Due to the wide variety of interconnects Mill-Max offers, the specific tolerances vary from product to product. If you need information regarding the tolerance of a particular part, please contact Technical Services.

RELATED LINKS AND DOCUMENTS

- Engineering Notebook: [Mill-Max Press-Fit Pins](#)
- Environmental Compliance: <https://www.mill-max.com/rohs>