

**Top View of Assembly**

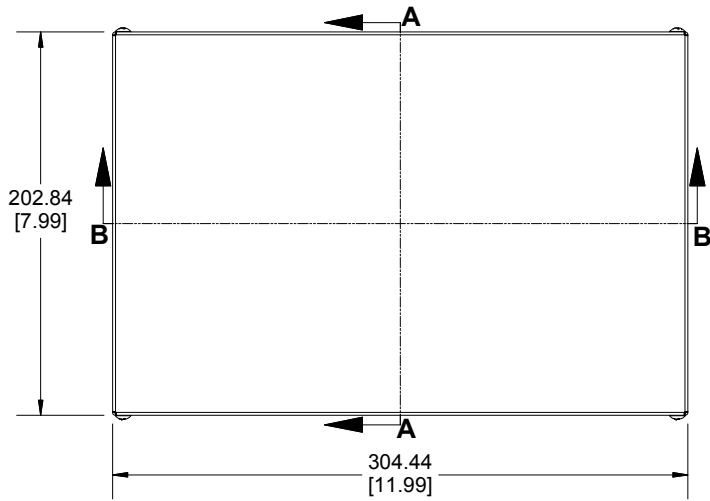

**SECTION A-A  
End View of Assembly**

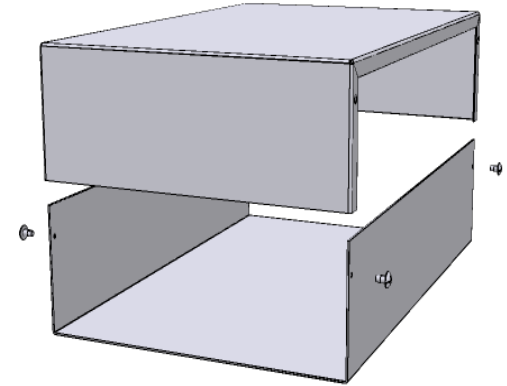
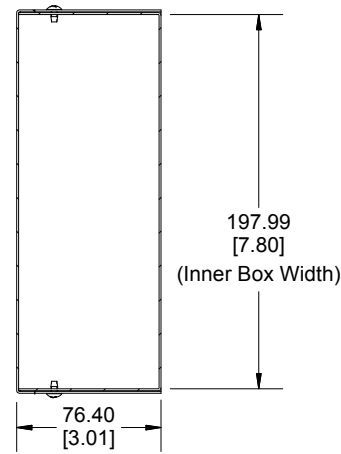

**SECTION B-B  
Side View of Assembly**

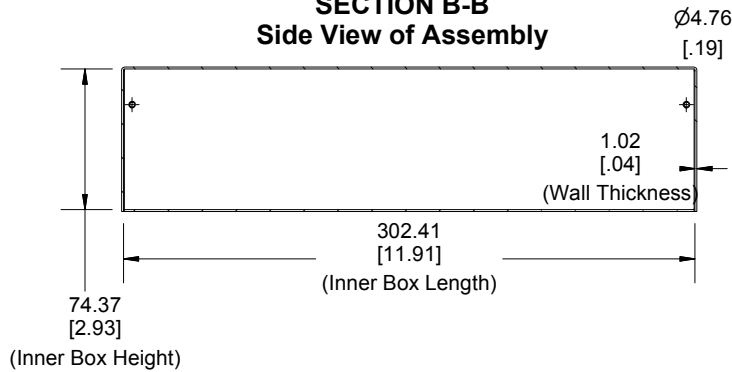

**Cover**

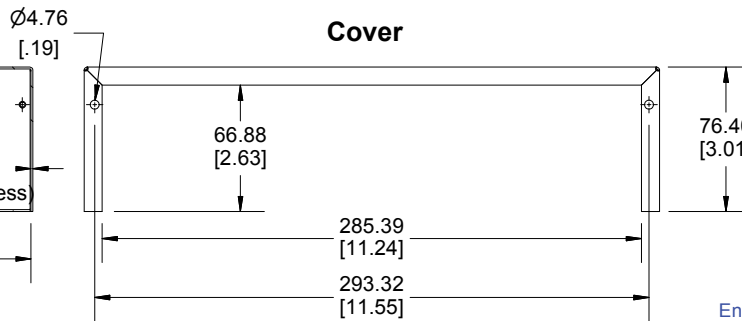

**Bottom**

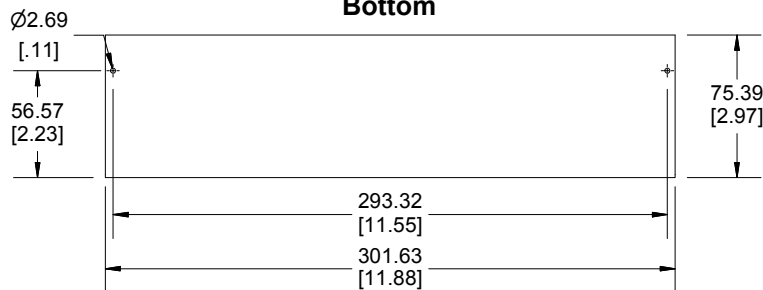

Enclosures can be Factory Modified ( Milling, Drilling, Printing etc.)  
Contact Factory [mjm@hammondmfg.com](mailto:mjm@hammondmfg.com) for quotes  
Solid models of this enclosure available in STEP or IGES.

**NOTE**

Purchased assembly includes bottom, cover and 4 cover screws.  
Bottom and cover are made from 0.04" Aluminum Panels.

**PART NUMBERS**

1411V Enclosure	
Natural Finish Enclosure	1411VU
ASA 61 Grey Enclosure	1411V
ACCESSORIES	
Plated Cover Screws (Pkg 6) [6-32 x 1/4" Self-Tapping Screws]	1421J6



Dimensions:  
mm  
[inches]