

Conductive Polymer Capacitor

General Catalog 2025

- Conductive Polymer Aluminum Electrolytic Capacitors
- Conductive Polymer Tantalum Solid Capacitors
- Conductive Polymer Aluminum Solid Capacitors
- Conductive Polymer Hybrid Aluminum Electrolytic Capacitors

SP-Cap

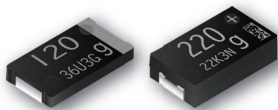

POSCAP

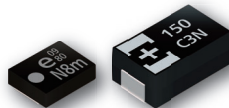

OS-CON

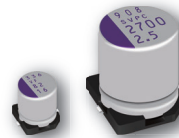

Hybrid



**IN Your
Innovation**



Electrolytic capacitors with conductive polymer to meet the needs of all electronic equipments in the world

SP-Cap, POSCAP, OS-CON, Hybrid

By using a high conductive polymer as the electrolyte, it has achieved in lower equivalent series resistance that could help and contribute excellent noise reduction and smoothing to an electrical fluctuation. In addition to that, that has excellence in product operational life, reliability and heat resistance.



* For details, see the right page

- **Low ESR**
 - Suitable as a decoupling capacitor to remove noises, because its impedance has ideal frequency characteristics.
 - Suitable as a smoothing capacitor for switching power supply or a backup capacitor for CPU because it allows large ripple current.
 - Suitable as a backup capacitor for the circuits that consumes large current at a high speed.
- **Long life**
- **Super low ESR**
- **Small size / Low profile**
- **Rush current resistance characteristics**
- **Wide capacitance range**
- **High voltage High reliability**
- **Environmental responsibility**
- **Temperature characteristics**
 - ESR has stable characteristics at when operating between -55°C to 150°C, suitable for applications used at low temperatures (under 0 °C).

Environmental responsibility

Principle

Industrial Solutions Company Group, Panasonic Corporation, Fulfills both environmental contribution and business growth, takes care of biodiversity, and contributes to create harmonization of environment, economy and society and to achieve a sustainable society.

RoHS compliance

All capacitors comply with RoHS directive (2011/65/EU) and (EU)2015/863.

Restricted Substance

Restricted substances of RoHS directive

- ◆ Cadmium(Cd) and it's compounds
- ◆ Lead(Pb) and it's compounds
- ◆ Mercury(Hg) and it's compounds
- ◆ Hexavalent chromium(Cr+6)
- ◆ Polybrominated biphenyls(PBBs)
- ◆ Polybrominated diphenyl ethers(PBDEs)
- ◆ Bis(2-ethylhexyl) phthalate (DEHP)
- ◆ Benzyl butyl phthalate (BBP)
- ◆ Dibutyl phthalate (DBP)
- ◆ Diisobutyl phthalate (DIBP)

Lead-free stance

All complete parts and homogenous materials of capacitors are lead-free. (JEITA, PHASE3)

ISO/IATF(ISO/TS)Certified

(1) Quality Approval

| Factory(Site) Applicable standard | Organization | Certificate number | Acquisition years |
|---|--------------|------------------------|-------------------|
| •Uji factory (Kyoto) | | | |
| ISO 9001:2015 | JQA | JQA-2524 | 1998.07.31 |
| IATF 16949:2016 | JQA | JQA-AU0162-14 | 2016.09.13 |
| •Yamaguchi factory (Yamaguchi) | | | |
| ISO 9001:2015 | JQA | JQA-2524 | 1998.07.31 |
| IATF 16949:2016 | JQA | JQA-AU0162-1 | 2007.02.23 |
| •Panasonic Industrial Devices Saga Co., Ltd. (Former:SAGA SANYO Industries Co., Ltd.)(Saga) | | | |
| ISO 9001:2015 | JQA | JQA-2524 | 1998.07.31 |
| IATF 16949:2016 | JQA | JQA-AU0162-10 | 2006.07.31 |
| •PIDSG (Singapore) | | | |
| ISO 9001:2015 | BSI | FM 612824 | 1994.12.08 |
| •PICID (Former:SJC) (Indonesia) | | | |
| ISO 9001:2015 | SGS | ID17/03853, ID19/04586 | 2006.03.26 |
| IATF 16949:2016 | SGS | ID19/04510 | 2011.03.01 |

(2) Environment Approval

| Factory(Site) Applicable standard | Organization | Certificate number | Acquisition years |
|---|--------------|--------------------|-------------------|
| •Uji factory (Kyoto) | | | |
| ISO 14001:2015 | JACO | EC10J0027 | 1996.12.26 |
| •Yamaguchi factory (Yamaguchi) | | | |
| ISO 14001:2015 | JACO | EC10J0027 | 1997.12.22 |
| •Panasonic Industrial Devices Saga Co., Ltd. (Former:SAGA SANYO Industries Co., Ltd.)(Saga) | | | |
| ISO 14001:2015 | JACO | EC10J0027 | 1998.03.10 |
| •PIDSG (Singapore) | | | |
| ISO 9001:2015 | AJA | AJA98/1151 | 1998.04.09 |
| ISO 14001:2015 | SGS | 16/03617 | 2010.02.15 |
| ISO 14001:2015 | SGS | 17/04090 | 2011.11.04 |

Conductive Polymer Capacitor INDEX

| Item | Page |
|---|------|
| Safety and Legal Matters to Be Observed | 1 |
| Characteristics portfolio / Basic structure | 2 |
| Circuit example / Application | 3 |

SP-Cap Conductive Polymer Aluminum Electrolytic Capacitors

| Matters to Be Observed When Using This Product (SP-Cap) | | 5 |
|---|--|----|
| Selection guide | Line-up / Diagram | 8 |
| | Voltage - Capacitance table | 10 |
| | Explanation of part numbers | 12 |
| | Mounting specifications | 13 |
| | Packing specifications | 14 |
| Series | JX : Endurance 125 °C 3000 h | 15 |
| | KX : Endurance 125 °C 5500 h | 17 |
| | TX : Endurance 135 °C 5500 h | 19 |
| | JZ : Large cap., 125 °C 3000 h | 21 |
| | KZ : Large cap., 125 °C 5500 h | 23 |
| | TZ : Large cap., 135 °C 5500 h | 25 |
| | CS,CT,CX : High voltage, Low profile | 27 |
| | SX : Large capacitance, Low ESR | 30 |
| | GX/GX-L : Large capacitance, Super low ESR | 32 |
| | LX : Large capacitance, Low ESR | 34 |
| | SR,LR,SS,LS,ST,LT : Low profile, Low ESR | 36 |
| | GY : Large capacitance, Super low ESR | 38 |
| | CY,SY : Endurance 85 °C 2000 h | 40 |
| HX : Endurance 125 °C 1000 h | 42 | |
| Replacement list for "Not recommended for new design" | | 44 |

POSCAP Conductive Polymer Tantalum Solid Capacitors

| Matters to Be Observed When Using This Product (POSCAP) | | 48 |
|---|---------------------------------------|----|
| Selection guide | Line-up / Diagram | 50 |
| | Voltage - Capacitance table | 53 |
| | Explanation of part numbers | 57 |
| | Mounting specifications | 58 |
| | Packing specifications | 59 |
| Series | TPS : 105 °C 2000 h | 60 |
| | TPSF : Super low ESR・Super low ESL | 61 |
| | TPE : Small size, Low profile | 62 |
| | TPF : Super low ESR | 66 |
| | TQT : High voltage, Large capacitance | 68 |
| | TQS : High voltage | 69 |
| | TQC : High voltage | 70 |
| | TA : Guaranteed at 85 °C 85 %RH | 74 |
| | TV : Guaranteed at 85 °C 85 %RH | 76 |
| | TH : 125 °C 1000 h | 77 |
| | TPB : Standard | 79 |
| | TC : 125 °C 1000 h | 81 |
| | TDC : 125 °C 1000 h | 83 |
| | TPC : Low profile | 85 |
| | Catalog deletion models | |
| EOL models | | 88 |

OS-CON Conductive Polymer Aluminum Solid Capacitors

| Matters to Be Observed When Using This Product (OS-CON) | | 90 | |
|---|-----------------------------|-------------------------------------|-----|
| Selection guide | Line-up / Diagram | 93 | |
| | Voltage - Capacitance table | 99 | |
| | Explanation of part numbers | 104 | |
| | Mounting specifications | 105 | |
| | Packing specifications | 106 | |
| Series | Surface mount type | SVT : 125°C 2000 h | 108 |
| | | SVPT : 105°C 20000 h | 110 |
| | | SVF : High voltage, 125°C 1000 h | 112 |
| | | SVPK : High voltage, 125°C 1000 h | 114 |
| | | SXV : Super high vol., 125°C 1000 h | 116 |
| | | SVPG : High ripple current | 118 |
| | | SVPF : High voltage, 105°C 5000 h | 120 |
| | | SVPA : Low ESR | 122 |
| | | SVPC : Low ESR | 124 |
| | | SVPD : 125 °C 2000h | 126 |
| | | SVPE : Low ESR | 128 |
| | | SVPS : 105 °C 5000h | 130 |
| | | SVQP : 125 °C 1000h | 132 |
| | SVP : Standard | 134 | |
| | Radial lead type | SEF : High voltage, 125°C 1000 h | 136 |
| | | SEK : High voltage, 125°C 1000 h | 138 |
| | | SEPG : High ripple current | 140 |
| | | SXE : Super high vol., 125°C 1000 h | 142 |
| | | SEPF : High voltage, 105°C 5000 h | 144 |
| | | SEPC : Super low ESR | 146 |
| | | SEQP : High voltage | 148 |
| SEP : Standard | | 150 | |

Hybrid Conductive Polymer Hybrid Aluminum Electrolytic Capacitors

| Matters to Be Observed When Using This Product (Hybrid) | | 153 | |
|---|-----------------------------|-----------------------|-----|
| Selection guide | Line-up / Diagram | 159 | |
| | Voltage - Capacitance table | 161 | |
| | Explanation of part numbers | 163 | |
| | Mounting specifications | 165 | |
| | Packing specifications | 166 | |
| Series | Surface mount type | ZA : 105 °C 10000 h | 167 |
| | | ZC : 125 °C 4000 h | 170 |
| | | ZK : 125 °C 4000 h | 173 |
| | | ZKU : 125 °C 4000 h | 175 |
| | | ZL : 135 °C 4000 h | 177 |
| | | ZT : 125 °C 4000 h | 179 |
| | | ZTU : 135 °C 4000 h | 181 |
| | | ZV : 135 °C 4000 h | 183 |
| | | ZVU : 135 °C 4000 h | 185 |
| | | ZS : 135 °C 4000 h | 187 |
| | | ZSU : 125 °C 4000 h | 189 |
| | | ZU : 135 °C 4000 h | 191 |
| | ZUU : 135 °C 4000 h | 193 | |
| | ZE : 145 °C 2000 h | 195 | |
| | ZF : 150 °C 1000 h | 197 | |
| | Radial lead type | ZA-A : 105 °C 10000 h | 199 |
| | | ZC-A : 125 °C 4000 h | 201 |
| | | ZK-A : 125 °C 4000 h | 204 |
| | | ZKU-A : 125 °C 4000 h | 206 |
| | | ZT-A : 125 °C 4000 h | 208 |
| | | ZS-A : 135 °C 4000 h | 210 |
| | | ZSU-A : 125 °C 4000 h | 212 |
| | | ZE-A : 145 °C 2000 h | 214 |
| | | ZF-A : 150 °C 1000 h | 216 |

Safety and Legal Matters to Be Observed

Product specifications and applications

- Please be advised that this product and product specifications are subject to change without notice for improvement purposes. Therefore, please request and confirm the latest delivery specifications that explain the specifications in detail before the final design, or purchase or use of the product, regardless of the application. In addition, do not use this product in any way that deviates from the contents of the company's delivery specifications.
- Unless otherwise specified in this catalog or the product specifications, this product is intended for use in general electronic equipment (AV products, home appliances, commercial equipment, office equipment, information and communication equipment, etc.).
When this product is used for the following special cases, the specification document suited to each application shall be signed/sealed (with Panasonic Industry and the user) in advance..These include applications requiring special quality and reliability, wherein their failures or malfunctions may directly threaten human life or cause harm to the human body (e.g.: space/aircraft equipment, transportation/traffic equipment, combustion equipment, medical equipment, disaster prevention/crime prevention equipment, safety equipment, etc.).

Safety design and product evaluation

- Please ensure safety through protection circuits, redundant circuits, etc., in the customer's system design so that a defect in our company's product will not endanger human life or cause other serious damage.
- This catalog shows the quality and performance of individual parts. The durability of parts varies depending on the usage environment and conditions. Therefore, please ensure to evaluate and confirm the state of each part after it has been mounted in your product in the actual operating environment before use.
If you have any doubts about the safety of this product, then please notify us immediately, and be sure to conduct a technical review including the above protection circuits and redundant circuits at your company.

Laws / Regulations / Intellectual property

- The transportation of dangerous goods as designated by UN numbers, UN classifications, etc., does not apply to this product. In addition, when exporting products, product specifications, and technical information described in this catalog, please comply with the laws and regulations of the countries to which the products are exported, especially those concerning security export control.
- Each model of this product complies with the RoHS Directive (Restriction of the use of hazardous substances in electrical and electronic equipment) (2011/65/EU and (EU) 2015/863). The date of compliance with the RoHS Directive and REACH Regulation varies depending on the product model.
Further, if you are using product models in stock and are not sure whether or not they comply with the RoHS Directive or REACH Regulation, please contact us by selecting "Sales Inquiry" from the inquiry form.
- During the manufacturing process of this product and any of its components and materials to be used, Panasonic Industry does not intentionally use ozone-depleting substances stipulated in the Montreal Protocol and specific bromine-based flame retardants such as PBBs (Poly-Brominated Biphenyls) / PBDEs (Poly-Brominated Diphenyl Ethers). In addition, the materials used in this product are all listed as existing chemical substances based on the Act on the Regulation of Manufacture and Evaluation of Chemical Substances.
- With regard to the disposal of this product, please confirm the disposal method in each country and region where it is incorporated into your company's product and used.
- The technical information contained in this catalog is intended to show only typical operation and application circuit examples of this product. This catalog does not guarantee that such information does not infringe upon the intellectual property rights of Panasonic Industry or any third party, nor imply that the license of such rights has been granted.
- Design, materials, or process related to technical owned by Panasonic Industry are subject to change without notice.

Panasonic Industry will assume no liability whatsoever if the use of our company's products deviates from the contents of this catalog or does not comply with the precautions. Please be advised of these restrictions.

Conductive polymer capacitor of Panasonic Industry

SP-Cap

Conductive Polymer Aluminum Electrolytic Capacitors (Stack Type)

- Super Low ESR
- Low profile
- Large capacitance

POSCAP

Conductive Polymer Tantalum Solid Capacitors (Sintered Type)

- Low ESR
- Small size
- Large capacitance

OS-CON

Conductive Polymer Aluminum Solid Capacitors (Wound Type)

- Low ESR
- High voltage
- Large capacitance

Hybrid

Conductive Polymer Hybrid Aluminum Electrolytic Capacitors (Wound Type)
Conductive Polymer + Electrolyte

- Low ESR
- High voltage
- High reliability

Characteristics Portfolio

Full coverage of the capacitor conductive market

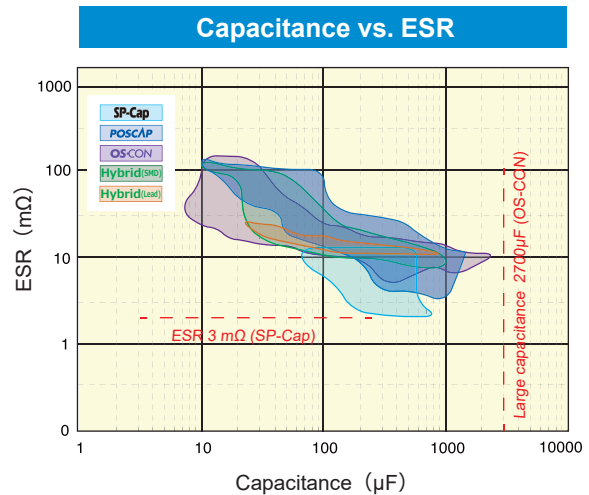
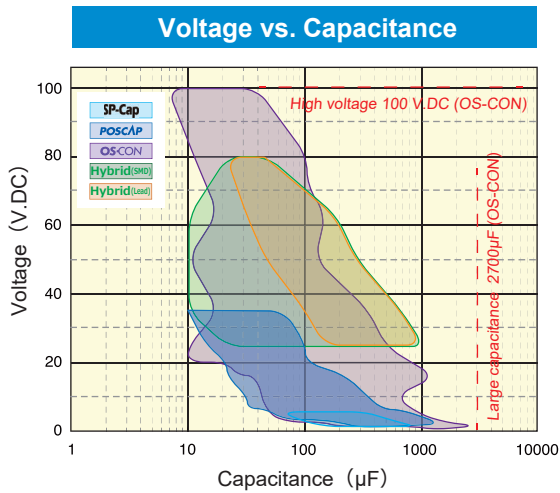

Basic structure

SP-Cap

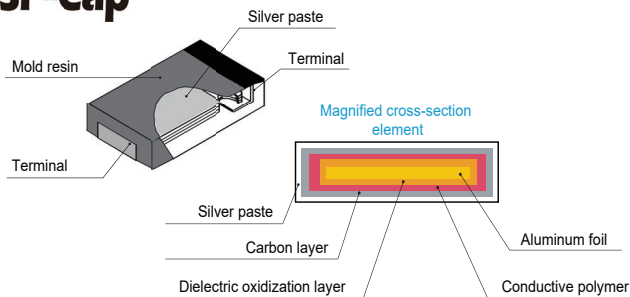

POSCAP

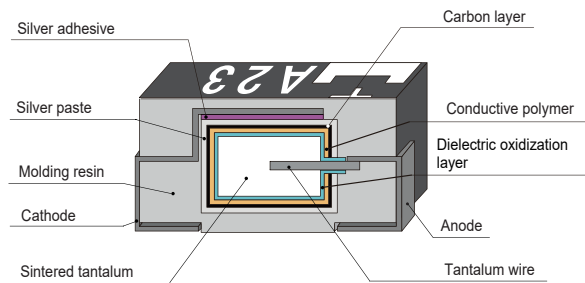

OS-CON Hybrid

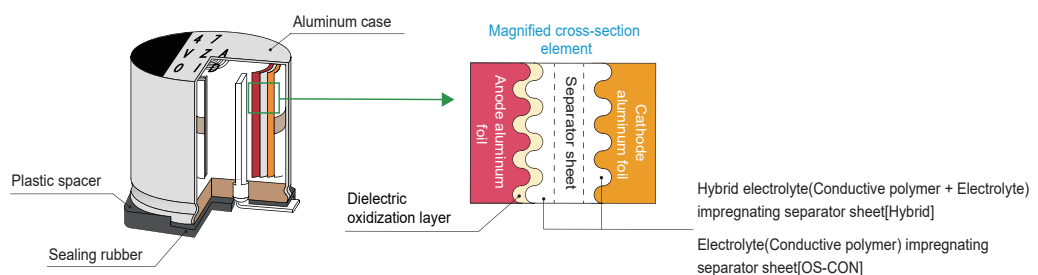

Examples of common use case four conductive products

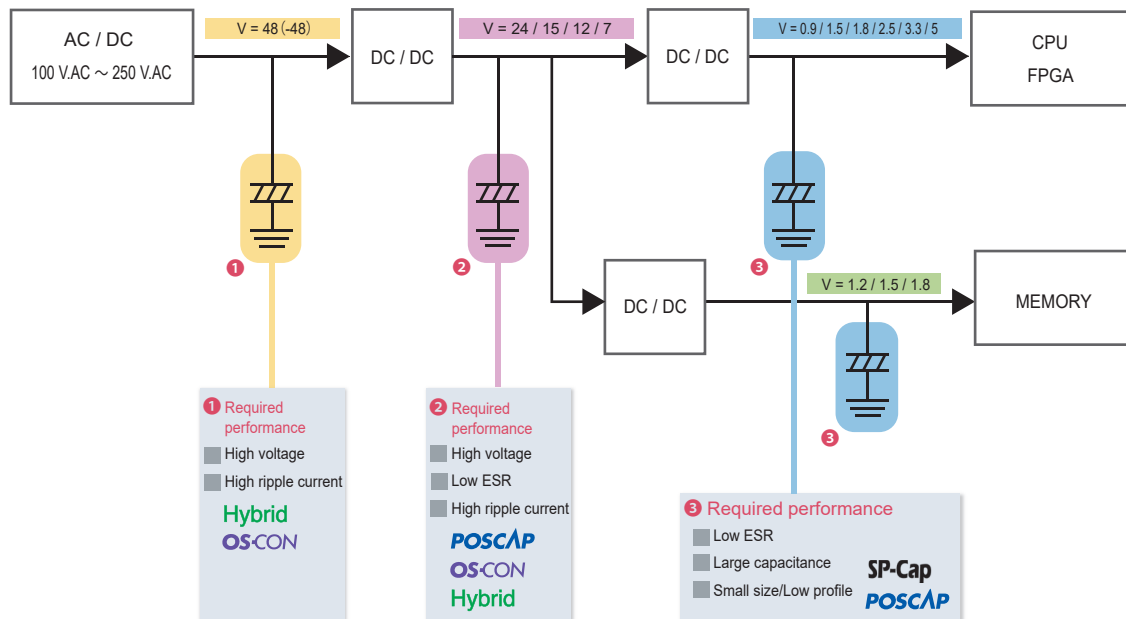

• You can select the optimal article from "size form and total cost" etc. besides an electrical property.

Application

| | SP-Cap | POSCAP | OS-CON | Hybrid |
|-------------------------------|----------------------|----------------|--------|--------|
| Laptop computer | • | • | | |
| Desktop computer | | | • | • |
| Audio/Visual | • | • | • | • |
| Server | • | • | • | • |
| Communications infrastructure | • | • | • | • |
| SSD, HDD | | • | | |
| Automotive | | • [※] | | • |
| Home appliance | | | • | • |
| Industry | Industrial equipment | • | • | • |
| | Industrial robot | | • | • |
| | Drone etc. | • | • | |

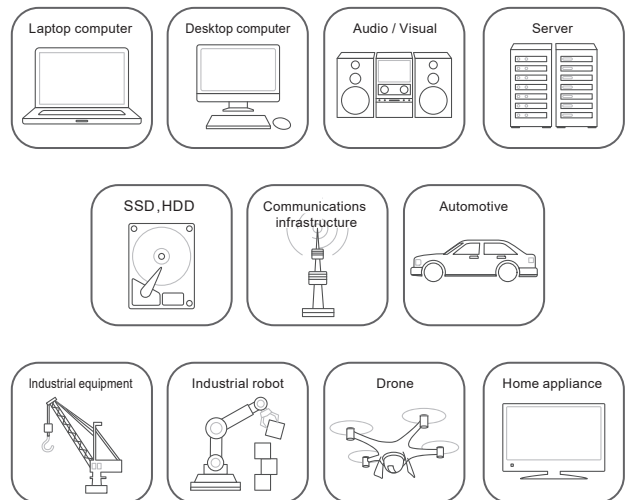

※ This product is not intended for use in any driving application or any other critical functions that affect passenger safety (e.g. Powertrain, ABS, Engine ECU, Airbag, etc.)
If the intended use of TA/TV series products is for use in other automotive related applications, please contact our sales team.
All requests are subject to approval.

• Main market

Conductive Polymer Aluminum Electrolytic Capacitors

SP-Cap™

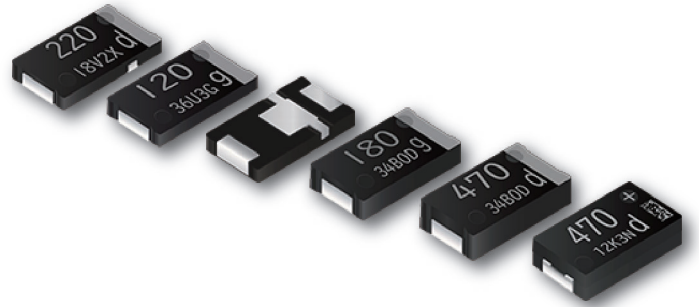

INDEX

| | |
|---|-----|
| Application Guidelines (SP-Cap) | P5 |
| Line-up / Diagram | P8 |
| Voltage - Capacitance table | P10 |
| Explanation of part numbers | P12 |
| Mounting / Packing specifications | P13 |
| Each series | P15 |
| Replacement list for “Not recommended for new design” | P44 |

Applications

Main market

Laptop computer

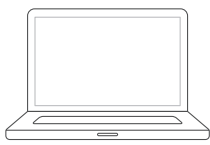

Server



Communications infrastructure

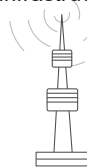

Industrial equipment

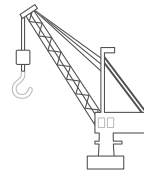

Audio / Visual

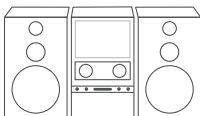

Smart phone
Tablet



Drone



Matters to Be Observed When Using This Product

(Conductive Polymer Aluminum Electrolytic Capacitors / SP-Cap)

Intended use

SP-Cap (all series) does not meet the quality standards required for automotive-related equipment. Therefore, we are unable to support compliance with related standards (such as AEC-Q200, PPAP, etc.). We shall not be responsible for any issues arising from the use of these products in such applications.

Use environments and cleaning conditions

■ This product (capacitor) is intended for standard general-purpose use in electronic equipment, and is not designed for use in the specific environments described below. Using the product in such specific environments or service conditions, therefore, may affect the performance of the product.

Please check with us about the performance and reliability of the product first before using the product.

- (1) Used in liquid, such as water, oil, chemicals, and organic solvents.
- (2) Used in a place exposed to direct sunlight, an outdoor place with no shielding, or a dusty place.
- (3) Used in a wet place (dew concentration on a resistor, water leakage, etc.), a place exposed to sea breeze, or a place filled with a corrosive gas, such as Cl₂, H₂S, NH₃, SO₂, or NO_x.
- (4) Used in an environment where static electricity and electromagnetic waves are strong.
- (5) The product is located close to a heating component or a flammable material, such as a vinyl cable, is placed near the product.
- (6) The product is used sealed with a resin, etc.
- (7) Solder flux of the soldered product is cleansed with a solvent, water, and a water-soluble cleaner.
(Be careful with water soluble solder flux.)
- (8) Used in an environment where an acidic or alkali atmosphere is present.
- (9) Used in an environment where excessive vibration or impact is applied to the product.
- (10) Used under a low atmospheric pressure condition or depressurized condition.

■ After soldering, clean the circuit board at a temperature of 60 °C or lower for 5 minutes or less. However, ensure to thoroughly rinse and dry it (at 100 °C for 20 minutes or less). The applicable solvents are as follows.

Pine Alpha ST-100S, Clean-thru 750H/750L/710M, Aqua Cleaner 210SEP, Sunelec B-12, DK be-clear CW-5790, Techno Cleaner 219, Cold Cleaner P3-375, Terpene Cleaner EC-7R, Techno Care FRW-17/FRW-1/FRV-1, AXREL 32, IPA (isopropyl alcohol)

- (1) Please contact us in advance for the use of cleaning agents other than those listed above and water except pure water.
- (2) Avoid using ozone-depleting substances as cleaning agents to protect the global environment.
- (3) Performing ultrasonic cleaning may cause terminal disconnection, which requires prior evaluation.

■ Do not apply strong force to this product. Doing so may adversely affect mounting by causing the deformation of electrode terminals or other defects.

In addition, the application of strong force may also lead to short circuits, disconnection, increased leakage currents, and damage to the outer packaging of the product. Do not hold the body of the product or apply force even after it is attached to the circuit board.

■ When the capacitor is used in a circuit where an impact voltage is applied or a high voltage is applied in a short period (transient phenomenon) or a high pulse voltage is applied, make sure to use the capacitor at a voltage equal to or lower than its rated voltage.

Response to anomalies and handling conditions

If this product heats up abnormally, then smoke may be generated from the exterior resin. In this case, immediately turn off the main power of the equipment and stop using it. Also, keep your face and hands away from the product as it may become hot and cause burns.

Reliability and product life

- Most of the failure modes are "short circuits" or "increased leakage currents." The main causes of failures are thermal stress, electrical stress, and mechanical stress due to reflow and operating temperature environments. Even within the range of the specified use conditions, it is possible to reduce the failure rate by mitigating the operating conditions such as the temperature and voltage. Therefore, please design equipment with a sufficient margin.
- The estimated failure rate is 8.2 Fit or less (estimated at 105 °C when the rated voltage is applied) based on data obtained from the company's reliability test, while the estimated market failure rate is 0.13 Fit or less (estimated at c = 0 and a confidence level of 60 %).

Circuit design and circuit board design

- Do not use this product in high-impedance voltage holding circuits, coupling circuits, time constant circuits, and those that are significantly affected by leakage currents. Also, do not connect two or more units of this product in series.
- Applying overvoltage that exceeds the rated voltage specified in the specifications or reverse voltage to this product may cause an increase in leakage currents or short circuits.
Applied voltage refers to the voltage value applied to a circuit, including the effects of the peak values of ripple voltage and transient instantaneous voltage, and does not only indicate the steady line voltage value. Design circuits so that the peak voltage does not exceed the specified voltage.
Use this product by regulating the operating voltage to keep it lower than or equal to the rated voltage even for impulse voltage circuits, applications involving transient phenomena where a considerably high voltage is applied in a short time, and cases where high pulse voltages are applied.
- Keep the operating temperature within the range stipulated in the specifications. Design your equipment in consideration of not only the ambient temperature where the equipment is placed and its internal temperature, but also the radiant heat from heating elements (power transistors, resistors, etc.) inside the equipment, and the temperature of this product, including self-heating due to ripple current.
- Regulate the ripple current within the rated range specified in the specifications when using the product.
Excessive ripple current causes increased leakage currents and short circuit failures due to self-heating.
Even if the ripple current is within the rated range, prevent the ripple voltage from applying overvoltage or reverse voltage to the product.
- The ESR rating is the value at the time of shipment from the factory. The ESR value may vary depending on the customer's usage conditions.
- Leakage currents may increase after reflow soldering, and also under no-load conditions at high temperatures, in high temperature and high humidity environments, or with sudden temperature changes, even if the operating environment is within the specified range. However, in most cases, SP-Cap reduces leakage currents due to its self-recovery action when voltage is applied.
- Insulate the circuit board surface directly under the mounting area of this product. Lay out your circuit board by defining the dimensions of lands with reference to the mounting specifications stipulated in the requirements.
The dimensions of the actual design circuit should enable the optimum mounting depending on conditions such as the circuit board, parts, and reflow.

Mounting and storage conditions

- Check the rating (capacitance, rated voltage), polarity, and land dimensions of this product before mounting it on the circuit board. When using mounting equipment, large pressure applied during mounting may lead to an increase in leakage currents, short circuits, disconnection, or falling off from the circuit board.
- Do not use flow and dip soldering. Reflow soldering can be used with the following methods. Please refer to the mounting specifications for the recommended conditions for using the atmospheric heat conduction method. Please contact us for the recommended conditions for using the VPS method.
 - (1) Atmospheric heat conduction method (infrared ray/hot-air system)
 - (2) VPS method (target series: CX, CT, SX, ST, GX, LX, LT, and HX)
- Soldering must be performed at a temperature of 350 °C or lower at the tip of the soldering iron and within an operation time of 10 seconds, without applying excessive force to the product.
In addition, do not remove this product for reuse once it is mounted. Soldering outside the specified conditions can cause short circuit failures, an increase in ESR, and other defects.
- Store this product in an environment with a temperature ranging from 5 °C to 30 °C and a humidity of 70% or lower by using a moisture barrier bag. The storage period before opening the moisture barrier bag is two years after manufacture, and after opening the bag is seven days. If these conditions are exceeded, then the outer package may be damaged due to thermal stress during mounting caused by moisture absorption by the package.
After opening the bag, use up all pieces of this product within the specified storage period.
- This product is composed of various metals and resins, requiring disposal as industrial waste.

Reference information

Guidelines

The matters to be observed when using this product cite the technical report issued by the Japan Electronics and Information Technology Industries Association, and EIAJ RCR-2367D issued in October 2017, "Safety application guide for fixed aluminum electrolytic capacitors for use in electronic equipment." Please refer to the above technical report for details.

Intellectual property

Panasonic Group provides customers with safe products and services. We are also making great efforts to protect our intellectual property rights for Panasonic Group products. Typical patents related to this product are as follows.

[U.S. patent]

USP Nos. 7136276, 7787234

Line up

■ Long life products

| Series | Part No. | Feature | Low profile | Low ESR | Low ESL | Large cap. | High temp. | Long life | High voltage | Category temperature (°C) | Rated voltage (V) | ESR (mΩ) | Capacitance (μF) | Size (mm) |
|--------|----------|--|-------------|---------|---------|------------|------------|-----------|--------------|---------------------------|-------------------|----------|------------------|-----------|
| | | | | | | | | | | | | | | L x W |
| | | | | | | | | | | | | | | 7.3x4.3 |
| | | | | | | | | | | | | | | H |
| JX | EEFJX--- | Guaranteed at 125 °C 3000 h | | ● | | | | ● | ● | -55 to 125 | 2 to 6.3 | 3 to 15 | 120 to 470 | 1.9 |
| KX | EEFKX--- | Guaranteed at 125 °C 5500 h | | ● | | | | ● | ● | -55 to 125 | 2 to 6.3 | 3 to 15 | 120 to 470 | 1.9 |
| TX | EEFTX--- | Guaranteed at 135 °C 5500 h | | ● | | | | ● | ● | -55 to 135 | 2 to 6.3 | 3 to 15 | 120 to 470 | 1.9 |
| JZ | EEFJZ--- | Guaranteed at 125 °C 3000 h Large capacitance | | ● | | ● | ● | ● | | -55 to 125 | 2 | 3 to 9 | 560 | 2.2 |
| KZ | EEFKZ--- | Guaranteed at 125 °C 5500 h Large capacitance | | ● | | ● | ● | ● | | -55 to 125 | 2 | 3 to 9 | 560 | 2.2 |
| TZ | EEFTZ--- | Guaranteed at 135 °C 5500 h Large capacitance | | ● | | ● | ● | ● | | -55 to 135 | 2 | 3 to 9 | 560 | 2.2 |

■ Standard products

| Series | Part No. | Feature | Low profile | Low ESR | Low ESL | Large cap. | High temp. | Long life | High voltage | Category temperature (°C) | Rated voltage (V) | ESR (mΩ) | Capacitance (μF) | Size (mm) |
|--------|----------|--|-------------|---------|---------|------------|------------|-----------|--------------|---------------------------|-------------------|-----------|------------------|-----------|
| | | | | | | | | | | | | | | L x W |
| | | | | | | | | | | | | | | 7.3x4.3 |
| | | | | | | | | | | | | | | H |
| CX | EEFCX--- | Standard | | | | | | | ● | -55 to 105 | 2 to 35 | 12 to 40 | 15 to 560 | 1.9 |
| CT | EEFCT--- | Low profile | ● | | | | | | ● | -55 to 105 | 4 to 35 | 15 to 40 | 15 to 180 | 1.4 |
| CS | EEFCS--- | Low profile | ● | | | | | | ● | -55 to 105 | 4 to 35 | 15 to 40 | 10 to 120 | 1.1 |
| SX* | EEFSX--- | Low ESR | | ● | | | | | | -55 to 105 | 2 to 6.3 | 4.5 to 9 | 82 to 560 | 1.9 |
| GX | EEFGX--- | Super low ESR High ripple current | | ● | | | | | | -55 to 105 | 2, 2.5 | 3 | 330 to 560 | 1.9 |
| LX | EEFLX--- | Low ESR · Low ESL | | ● | ● | | | | | -55 to 105 | 2, 2.5 | 4.5 to 6 | 330 to 560 | 1.9 |
| ST | EEFST--- | Low profile · Low ESR | ● | ● | | | | | | -55 to 105 | 2, 2.5 | 6 | 270 to 330 | 1.4 |
| LT | EEFLT--- | Low profile Low ESR · Low ESL | ● | ● | ● | | | | | -55 to 105 | 2, 2.5 | 6 | 270 to 330 | 1.4 |
| SS | EEFSS--- | Low profile · Low ESR | ● | ● | | | | | | -55 to 105 | 2, 2.5 | 6 | 180 to 220 | 1.1 |
| LS | EEFLS--- | Low profile Low ESR · Low ESL | ● | ● | ● | | | | | -55 to 105 | 2, 2.5 | 6 | 180 to 220 | 1.1 |
| SR | EEFSR--- | Low profile (1.0 mm max.) Low ESR | ● | ● | | | | | | -55 to 105 | 2 to 6.3 | 4.5 to 9 | 68 to 220 | 1.0max. |
| LR | EEFLR--- | Low profile (1.0 mm max.) Low ESR · Low ESL | ● | ● | ● | | | | | -55 to 105 | 2 to 6.3 | 4.5 to 9 | 68 to 220 | 1.0max. |
| GY | EEFGY--- | Super low ESR / High ripple current / Height 3.0 mm max. | | ● | | ● | | | | -55 to 105 | 2, 2.5 | 3 | 680 to 820 | 2.8 |
| CY | ECGCY--- | Guaranteed at 85 °C Height 3.0 mm max. | | | | ● | | | | -55 to 85 | 4, 6.3 | 15 | 330 to 470 | 2.8 |
| SY | ECGSY--- | Low ESR / Guaranteed at 85 °C / Height 3.0 mm max. | | ● | | ● | | | | -55 to 85 | 4, 6.3 | 9 | 330 to 470 | 2.8 |
| HX | EEFHX--- | Guaranteed at 125 °C | | | | | ● | ● | | -55 to 125 | 2 to 25 | 4.5 to 40 | 15 to 470 | 1.9 |

• 2 to 6.3 V : On sale
 • 10 to 35 V : Not recommended for new design
 • Click [here](#) for Replacement (10 to 35 V)
 * 82 to 150 μF: Not recommended for new design
 Click [here](#) for Replacement

Series flow chart

■ Long life products

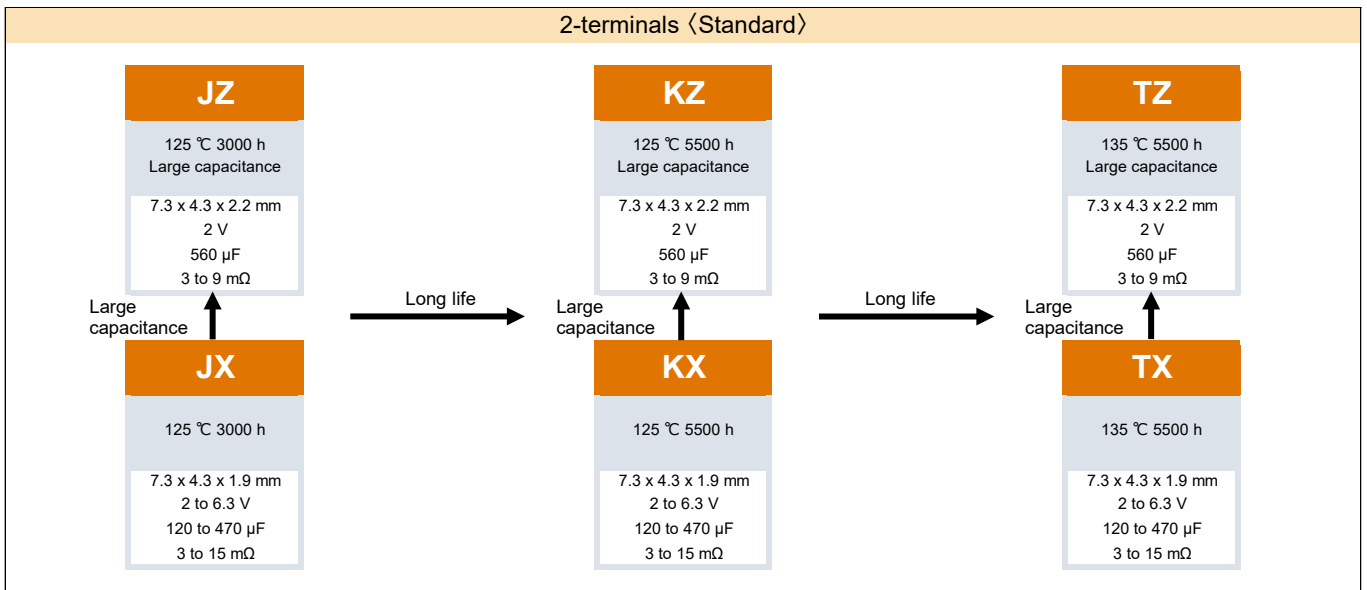

■ Standard products

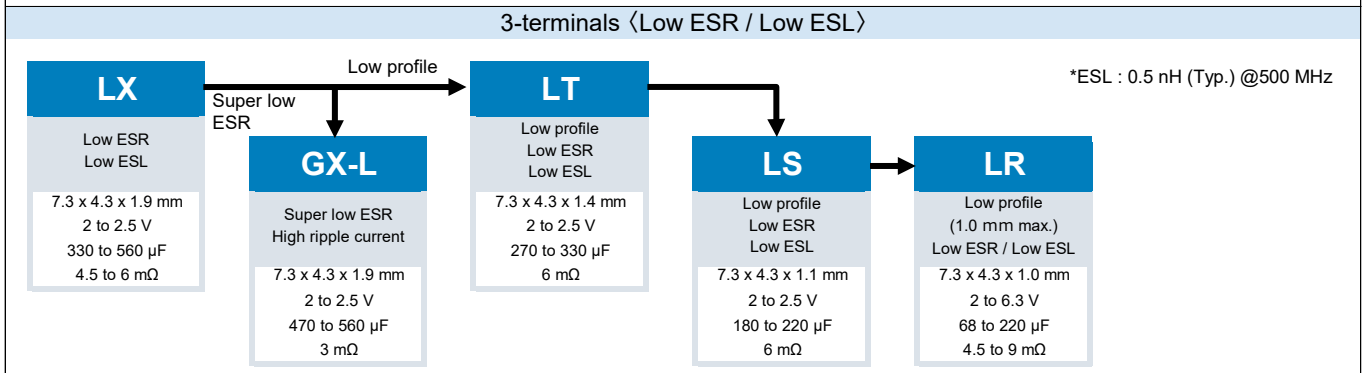
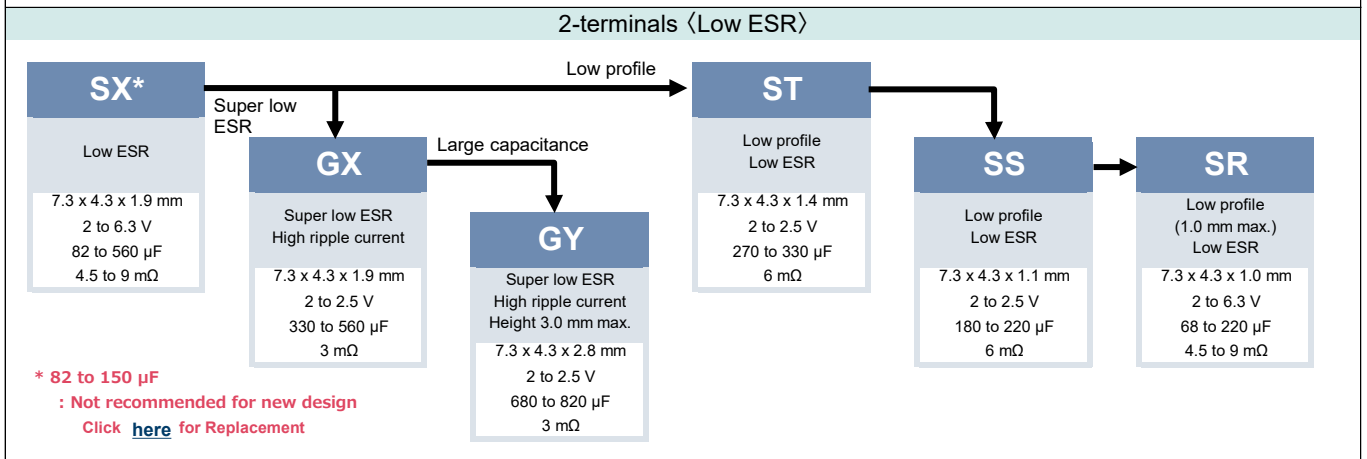
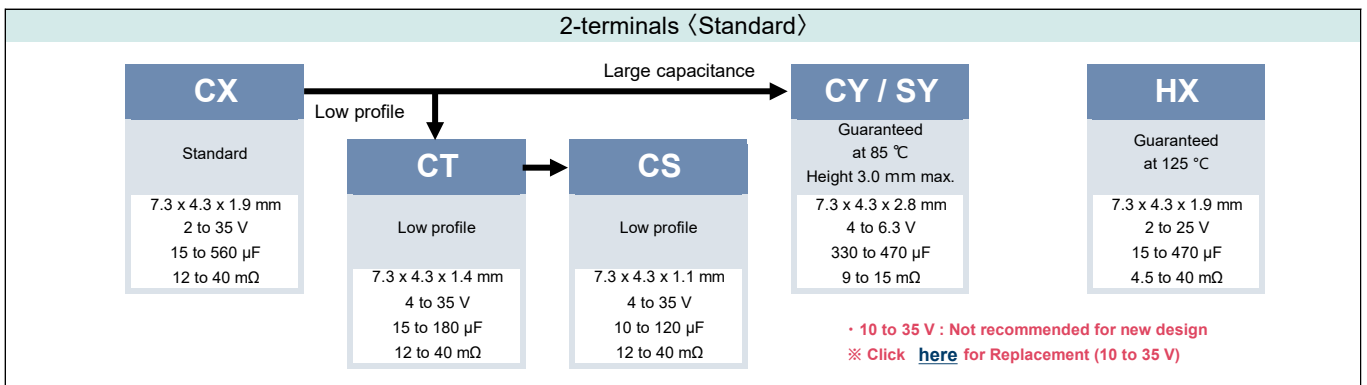

Voltage - Capacitance table (Vol. : 2.0 to 6.3 V / Cap. : 10 to 120 μ F)

Series
(ESR m Ω)

| V | μ F | 10 | 15 | 22 | 33 | 47 | 56 | 68 | 82 | 100 | 120 |
|-----|---------|----|----|----|----|----|----|------------|-----------|------------|------------|
| 2.0 | | | | | | | | | | | |
| | | | | | | | | | | | |
| | | | | | | | | | | | |
| | | | | | | | | | | | |
| | | | | | | | | | | | |
| | | | | | | | | | | | |
| | | | | | | | | | | | |
| | | | | | | | | | | | |
| 2.5 | | | | | | | | | | | |
| | | | | | | | | | | | |
| | | | | | | | | | | | |
| | | | | | | | | | | | |
| | | | | | | | | | | | |
| | | | | | | | | | | | |
| | | | | | | | | | | | |
| | | | | | | | | | | | |
| 4.0 | | | | | | | | | SX (9) | SX (9) | CS (15) |
| | | | | | | | | | | | SR (9) |
| | | | | | | | | | | | LR (9) |
| | | | | | | | | | | | |
| | | | | | | | | | | | |
| | | | | | | | | | | | |
| | | | | | | | | | | | |
| | | | | | | | | | | | |
| 6.3 | | | | | | | | CS (15) | | CT (15) | CX (15) |
| | | | | | | | | SR (9) | | CX (15) | SX (7) |
| | | | | | | | | LR (9) | | | JX (15) |
| | | | | | | | | | | | KX (15) |
| | | | | | | | | | | | TX (15) |
| | | | | | | | | | | | |
| | | | | | | | | | | | |
| | | | | | | | | | | | |

Size list LxWxH (mm)

| | | | |
|------------|----------------------|--------------------------------|-----------------|
| SR, LR | 7.3 x 4.3 x 1.0 max. | CX, GX, LX, LX, JX, KX, TX, HX | 7.3 x 4.3 x 1.9 |
| SS, LS, CS | 7.3 x 4.3 x 1.1 | JZ, KZ, TZ | 7.3 x 4.3 x 2.2 |
| CT, ST, LT | 7.3 x 4.3 x 1.4 | CY, SY | 7.3 x 4.3 x 2.8 |

Voltage - Capacitance table (Vol. : 2.0 to 6.3 V / Cap. : 150 to 820 μ F)

Series
(ESR m Ω)

| V | μ F | 150 | 180 | 220 | 270 | 330 | 390 | 470 | 560 | 680 | 820 |
|-----|---------|---------------|---------------|----------------|-----------------|--------------------|-----------------|--------------------|-----------------|-----------|-----------|
| 2.0 | | | SX (9) | CX (15) | CX (12) | CX (15,12) | CX (15) | CX (15) | CX (15) | | GY (3) |
| | | | | SX (9) | SX (9,6,4.5) | SX (9,6,4.5) | SX (9,6,4.5) | SX (9,6,4.5) | SX (4.5) | | |
| | | | | SR (6,4.5) | | GX (3) | | GX (3) | GX (3) | | |
| | | | | LR (6,4.5) | | LX (6,4.5) | | GX-L (3) | GX-L (3) | | |
| | | | | SS (6) | | ST (6) | | LX (6,4.5) | LX (6,4.5) | | |
| | | | | LS (6) | | LT (6) | | JX (9,4.5,3) | JZ (9,4.5,3) | | |
| | | | | | | JX (9) | | KX (9,4.5,3) | KZ (9,4.5,3) | | |
| | | | | | | KX (9) | | HX (15,9,6,4.5) | TZ (9,4.5,3) | | |
| | | | | | | TX (9) | | TX (9,4.5,3) | | | |
| 2.5 | | SX (9) | SX (9) | CX (15) | SX (7) | CX (15) | CX (15) | CX (15) | | GY (3) | |
| | | | SR (6,4.5) | SX (9,7) | ST (6) | SX (9,6) | SX (9,6,4.5) | SX (9,6,4.5) | | | |
| | | | LR (6,4.5) | JX (9) | LT (6) | GX (3) | JX (9,4.5,3) | GX (3) | | | |
| | | | SS (6) | KX (9) | | LX (6,4.5) | KX (9,4.5,3) | GX-L (3) | | | |
| | | | LS (6) | TX (9) | | JX (9) | TX (9,4.5,3) | LX (6,4.5) | | | |
| | | | | | | KX (9) | | JX (9,4.5,3) | | | |
| | | | | | | HX (15,9,6,4.5) | | KX (9,4.5,3) | | | |
| | | | | | | TX (9) | | HX (15,9,6,4.5) | | | |
| 4.0 | | CX (15) | CT (15) | CX (15, 12) | CX (15) | CX (15) | | CY (15) | | | |
| | | SX (9,7) | CX (15,12) | SX (9) | SX (9) | SX (9,6) | | SY (15) | | | |
| | | JX (15) | SX (9) | JX (15) | | | | | | | |
| | | KX (15) | JX (15) | KX (15) | | | | | | | |
| | | TX (15) | KX (15) | TX (15) | | | | | | | |
| | | | TX (15) | | | | | | | | |
| 6.3 | | CX (15,12) | CX (15) | CX (15) | | CY (15) | | | | | |
| | | SX (9) | SX (9) | SX (9) | | SY (9) | | | | | |
| | | JX (15) | | | | | | | | | |
| | | KX (15) | | | | | | | | | |
| | | TX (15) | | | | | | | | | |

Size list LxWxH (mm)

| | | | |
|------------|----------------------|--------------------------------|-----------------|
| SR, LR | 7.3 x 4.3 x 1.0 max. | CX, GX, LX, LX, JX, KX, TX, HX | 7.3 x 4.3 x 1.9 |
| SS, LS, CS | 7.3 x 4.3 x 1.1 | JZ, KZ, TZ | 7.3 x 4.3 x 2.2 |
| CT, ST, LT | 7.3 x 4.3 x 1.4 | CY, SY | 7.3 x 4.3 x 2.8 |

Explanation of part numbers

◇ Part number system

| EEF | | CX | | 0E | | 471 | | R | |
|-------------------------------------|------------------------|---------------------|------|---------------------------|------|-------------------------------|------|--------------------------------|--|
| Product classification 3 figures | | Series 2 figures | | Voltage code 2 figures | | Capacitance code 3 figures | | Special code 1 to 2 figures | |
| Series | Product classification | Series | Code | Voltage (V) | Code | Cap. (μF) | Code | | |
| JX | EEF | JX | JX | 2 | 0D | 10 | 100 | | |
| KX | | KX | KX | 2.5 | 0E | 15 | 150 | | |
| TX | | TX | TX | 4 | 0G | 22 | 220 | | |
| JZ | | JZ | JZ | 6.3 | 0J | 33 | 330 | | |
| KZ | | KZ | KZ | 10 | 1A | 47 | 470 | | |
| TZ | | TZ | TZ | 16 | 1C | 56 | 560 | | |
| CX | | CX | CX | 20 | 1D | 68 | 680 | | |
| CT | | CT | CT | 25 | 1E | 100 | 101 | | |
| CS | | CS | CS | 35 | 1V | 120 | 121 | | |
| SX | | SX | SX | | | 150 | 151 | | |
| LX | | LX | LX | | | 180 | 181 | | |
| GX | | GX | GX | | | 220 | 221 | | |
| ST | | ST | ST | | | 270 | 271 | | |
| LT | | LT | LT | | | 330 | 331 | | |
| SS | | SS | SS | | | 390 | 391 | | |
| LS | | LS | LS | | | 470 | 471 | | |
| SR | | SR | SR | | | 560 | 561 | | |
| LR | | LR | LR | | | 680 | 681 | | |
| GY | GY | GY | | | 820 | 821 | | | |
| CY | ECG | CY | CY | | | | | | |
| SY | | SY | SY | | | | | | |
| HX | EEF | HX | HX | | | | | | |

| Height (mm) | Series | Special code | ESR (mΩ max.) | Terminals | |
|-------------|----------------|--------------|-----------------------------------|-----------|---|
| | | | | 2 | 3 |
| 1.9 ± 0.1 | JX KX TX | RF | 15 | ○ | |
| | | RE | 9 | ○ | |
| | | RC | 4.5 | ○ | |
| | | RB | 3 | ○ | |
| 2.2 ± 0.1 | JZ KZ TZ | RE | 9 | ○ | |
| | | RC | 4.5 | ○ | |
| | | RB | 3 | ○ | |
| 1.9 ± 0.1 | CX | R | 15 (to 6.3 V), 40 (10 V to 35 V) | ○ | |
| | | XR | 12 | ○ | |
| | SX | ER | 9 | ○ | |
| | | E7 | 7 | ○ | |
| | | XE | 6 | ○ | |
| | GX | R | 3 | ○ | |
| | | L | 3 | | ○ |
| | LX | R | 6 | | ○ |
| | | R4 | 4.5 | | ○ |
| | | R | 15 (to 2.5 V), 40 (10 V to 25 V) | ○ | |
| | | R9 | 9 | ○ | |
| | HX | R6 | 6 | ○ | |
| R4 | | 4.5 | ○ | | |
| R4 | | 4.5 | ○ | | |
| 1.4 ± 0.1 | CT ST LT | R | 15 (to 6.3 V), 40 (10 V to 35 V) | ○ | |
| | | R | 6 | ○ | |
| | | R | 6 | | ○ |
| 1.1 ± 0.1 | CS SS LS | R | 15 (to 6.3 V), 40 (10 V to 35 V) | ○ | |
| | | R | 6 | ○ | |
| | | R | 6 | | ○ |
| 1.0 (max.) | SR | R | 6 (to 2.5 V), 9 (4 V to 6.3 V) | ○ | |
| | | R4 | 4.5 | ○ | |
| | LR | R | 6 (to 2.5 V), 9 (4 V to 6.3 V) | | ○ |
| | | R4 | 4.5 | | ○ |
| 2.8 ± 0.2 | GY CY SY | R | 3 | ○ | |
| | | R | 15 | ○ | |
| | | R | 9 | ○ | |

Mounting specification

● Recommendable reflow soldering

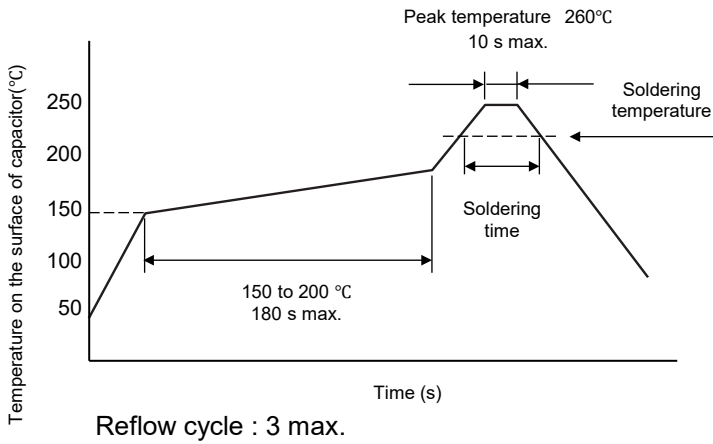

Soldering temperature and soldering time

| Temperature | Time |
|-------------|------------|
| ≥ 255°C | 30 s max. |
| ≥ 230°C | 130 s max. |
| ≥ 217°C | 150 s max. |

SP-Cap recommended profile condition of the IPC/J-STD-020F standard

● Typical land pattern

□ 2-terminals

For standard terminal (C*, S*, G*, J*, K*, T*, HX series)

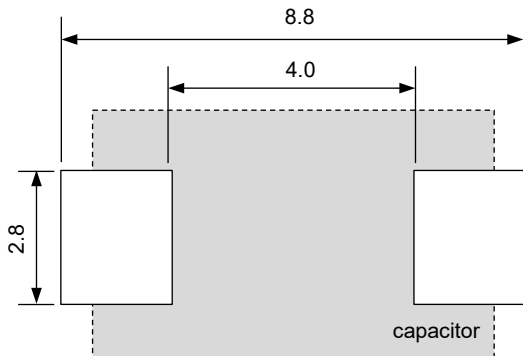

Unit:mm

□ 3-terminals

For low ESL terminal (L*, GX-L series)

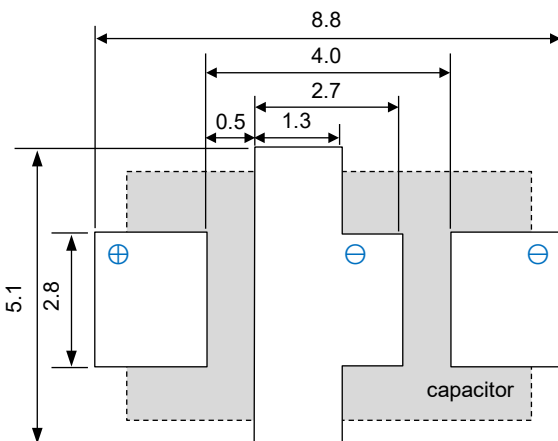

〈VIA〉

For low ESL terminal (L*, GX-L series)

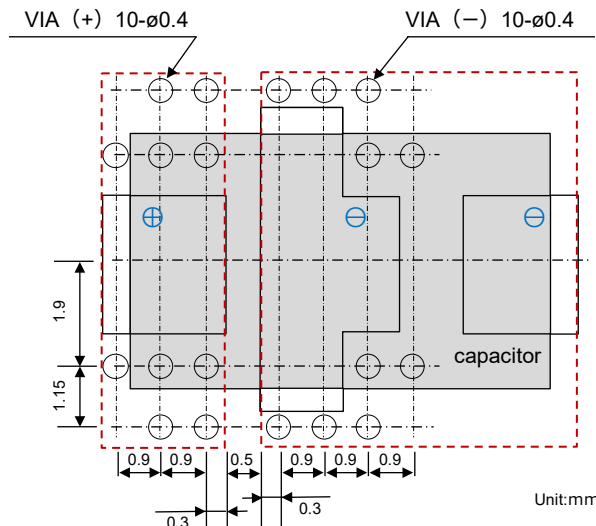

Unit:mm

Packaging specifications

● Reel dimensions

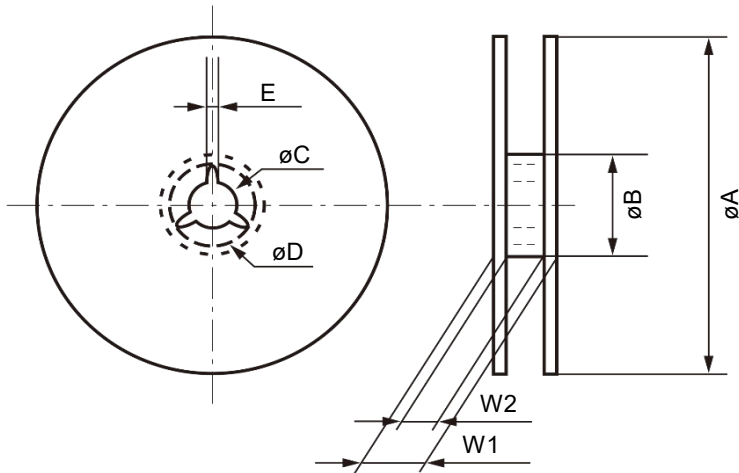

Unit:mm

| Reel | øA | øB | øC | øD | E | W1 | W2 |
|------|---------|--------|----------|----------|---------|----------|----------|
| ø330 | 330 ± 2 | 80 ± 1 | 13 ± 0.2 | 21 ± 0.8 | 2 ± 0.5 | 17.5 ± 1 | 13.5 ± 1 |

● Embossed tapping (12mm tape)

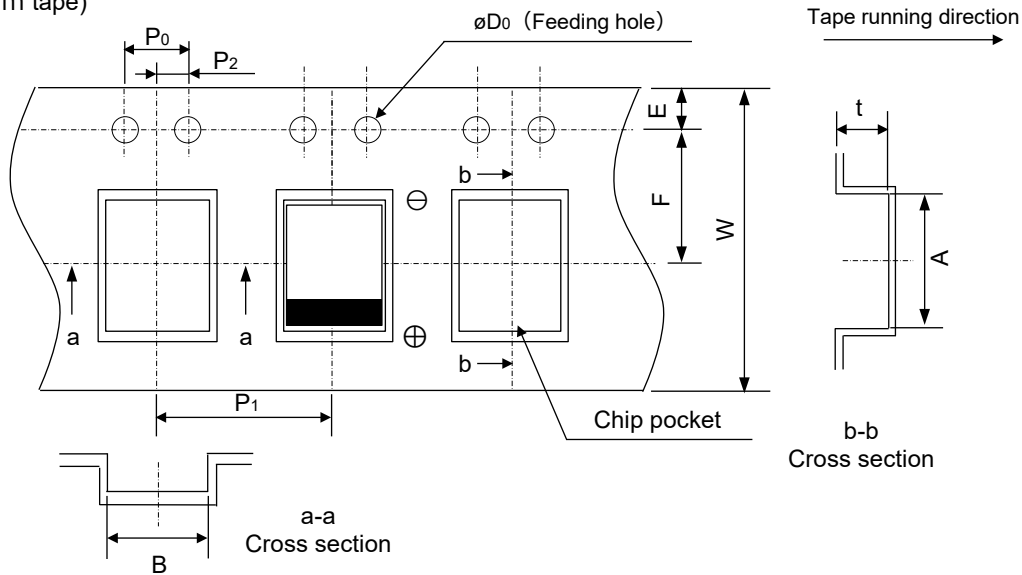

Unit:mm

| A | B | W | F | E | P1 | P2 | P0 |
|-----------|-----------|----------|-----------|------------|-----------|-----------|-----------|
| 7.6 ± 0.2 | 4.5 ± 0.2 | 12 ± 0.3 | 5.5 ± 0.1 | 1.75 ± 0.1 | 8.0 ± 0.1 | 2.0 ± 0.1 | 4.0 ± 0.1 |

| øD ₀ | Upper row : Product height / Lower berth : t | | | |
|----------------------------------|--|------------|-----------|-----------|
| | to 1.1 | 1.4 to 1.9 | 2.2 | 2.8 |
| 1.5 ^{+0.1} ₀ | 1.5 ± 0.2 | 2.4 ± 0.2 | 2.9 ± 0.2 | 3.5 ± 0.2 |

● Packaging box dimensions

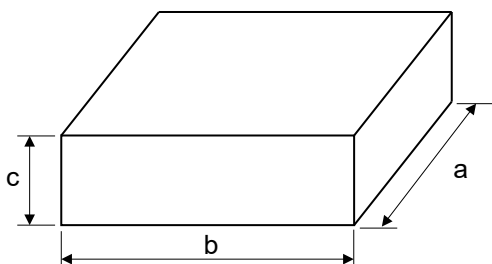

Unit:mm

| Reel | a | b | c |
|------|----------|----------|----------|
| ø330 | 400 max. | 400 max. | 135 max. |

Conductive Polymer Aluminum Electrolytic Capacitors

Surface Mount Type

JX series [High temperature long life product]



Notice: This product is not intended for use in automotive applications.

Features

- Endurance 125 °C 3000 h
- Damp heat 85°C 85% 1000 h
- Low ESR (3 to 15 mΩ)
- RoHS compliance, Halogen free

Specifications

| Series | JX | | | |
|----------------------------|--|-----------------------------------|--------------|--------------|
| Category temp. range | -55 °C to +125 °C | | | |
| Rated voltage range | 2.0 V to 6.3 V | | | |
| Category voltage range | 1.6 V, 2.0 V, 3.2 V, 5.0 V | | | |
| Rated cap. range | 120 μF to 470 μF | | | |
| Capacitance tolerance | ±20 % (120 Hz / +20 °C) | | | |
| DC leakage current | I ≤ 0.1 CV (μA) 2 minutes | | | |
| Dissipation factor (tan δ) | ≤ 0.1 (120 Hz / + 20 °C) | | | |
| Surge voltage (V) | Rated voltage × 1.25 (15 °C to 35 °C) | | | |
| Endurance | +125 °C 3000 h, category voltage applied | | | |
| | Capacitance change | Within ±20 % of the initial value | | |
| | Dissipation factor (tan δ) | ≤ 2 times of the initial limit | | |
| | DC leakage current | ≤ 3 times of the initial limit | | |
| Damp heat (Steady state) | +85 °C, 85 % RH, 1000 h, No-applied voltage | | | |
| | Capacitance change of initial measured value | 2.0 V, 2.5 V | 4.0 V | 6.3 V |
| | | +70 %, -20 % | +60 %, -20 % | +50 %, -20 % |
| | Dissipation factor (tan δ) | ≤ 2 times of the initial limit | | |
| DC leakage current | ≤ 5 times of the initial limit | | | |

Marking

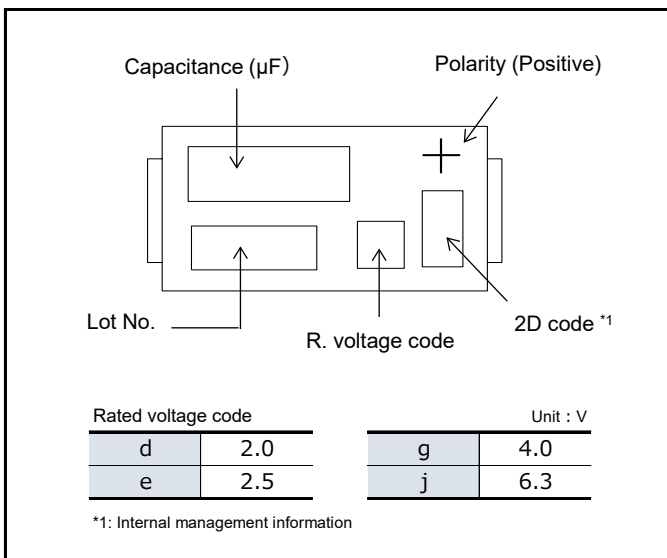

Dimensions (not to scale)

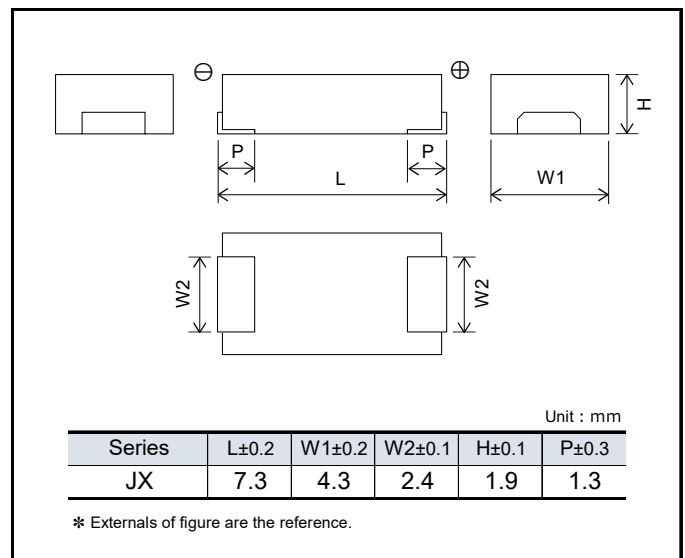

Explanation of part numbers

◇ Part number system e.g.: EEFJX0D331RE

| EEF | | JX | | 0D | | 331 | | RE | | | |
|--------|------------------------|--------|------|-------------------|------|------------------|------|------------------|------|----------|--------------|
| Series | Product classification | Series | Code | Rated Voltage (V) | Code | Capacitance (μF) | Code | Capacitance (μF) | Code | ESR (mΩ) | Special code |
| JX | EEF | JX | JX | 2.0 | 0D | 120 | 121 | 330 | 331 | 3 | RB |
| | | | | 2.5 | 0E | 150 | 151 | 390 | 391 | 4.5 | RC |
| | | | | 4.0 | 0G | 180 | 181 | 470 | 471 | 9 | RE |
| | | | | 6.3 | 0J | 220 | 221 | | | 15 | RF |

Characteristics list

| Series | Rated voltage [105 °C] (V) | Category voltage [125 °C] (V) | Capacitance (μF) | Case size (mm) | | | Specification | | Part number | Min. Packaging Qty (pcs) |
|--------|----------------------------|-------------------------------|------------------|----------------|-----|-----|---------------------------------------|-----------------------------|--------------|--------------------------|
| | | | | L | W | H | Ripple current* ¹ (mA rms) | ESR* ² (mΩ max.) | | |
| JX | 2.0 | 1.6 | 330 | 7.3 | 4.3 | 1.9 | 6300 | 9 | EEFJX0D331RE | 3500 |
| | | | | 7.3 | 4.3 | 1.9 | 6300 | 9 | EEFJX0D471RE | 3500 |
| | | | 470 | 7.3 | 4.3 | 1.9 | 8500 | 4.5 | EEFJX0D471RC | 3500 |
| | | | | 7.3 | 4.3 | 1.9 | 10200 | 3 | EEFJX0D471RB | 3500 |
| | 2.5 | 2.0 | 220 | 7.3 | 4.3 | 1.9 | 6300 | 9 | EEFJX0E221RE | 3500 |
| | | | | 7.3 | 4.3 | 1.9 | 6300 | 9 | EEFJX0E331RE | 3500 |
| | | | 390 | 7.3 | 4.3 | 1.9 | 6300 | 9 | EEFJX0E391RE | 3500 |
| | | | | 7.3 | 4.3 | 1.9 | 8500 | 4.5 | EEFJX0E391RC | 3500 |
| | | | 470 | 7.3 | 4.3 | 1.9 | 10200 | 3 | EEFJX0E391RB | 3500 |
| | | | | 7.3 | 4.3 | 1.9 | 6300 | 9 | EEFJX0E471RE | 3500 |
| | | | | 7.3 | 4.3 | 1.9 | 8500 | 4.5 | EEFJX0E471RC | 3500 |
| | | | | 7.3 | 4.3 | 1.9 | 10200 | 3 | EEFJX0E471RB | 3500 |
| | 4.0 | 3.2 | 150 | 7.3 | 4.3 | 1.9 | 5100 | 15 | EEFJX0G151RF | 3500 |
| | | | 180 | 7.3 | 4.3 | 1.9 | 5100 | 15 | EEFJX0G181RF | 3500 |
| | | | 220 | 7.3 | 4.3 | 1.9 | 5100 | 15 | EEFJX0G221RF | 3500 |
| | 6.3 | 5.0 | 120 | 7.3 | 4.3 | 1.9 | 5100 | 15 | EEFJX0J121RF | 3500 |
| | | | 150 | 7.3 | 4.3 | 1.9 | 5100 | 15 | EEFJX0J151RF | 3500 |

*1: Ripple current (100 kHz / +45 °C)

*2: ESR (100 kHz / +20 °C)

◆ Please refer to each page in this catalog for "Reflow conditions" and "Taping specifications".

Temperature coefficient of ripple current

| Temperature | | T ≤ 45 °C | 45 °C < T ≤ 85 °C | 85 °C < T ≤ 125 °C |
|----------------|-------------|-----------|-------------------|--------------------|
| 2.0 V to 6.3 V | Coefficient | 1.0 | 0.7 | 0.25 |

◆ Ripple current should be controlled so that surface temperature of capacitor does not exceed the category temperature.

Conductive Polymer Aluminum Electrolytic Capacitors

Surface Mount Type

KX series [High temperature long life product]



Notice: This product is not intended for use in automotive applications.

Features

- Endurance 125 °C 5500 h
- Damp heat 85°C 85% 1000 h
- Low ESR (3 ~ 15 mΩ max.)
- RoHS compliance, Halogen free

Specifications

| Series | KX | | | |
|----------------------------|--|-----------------------------------|--------------|--------------|
| Category temp. range | -55 °C to +125 °C | | | |
| Rated voltage range | 2.0 V to 6.3 V | | | |
| Category voltage range | 1.6 V, 2.0 V, 3.2 V, 5.0 V | | | |
| Rated cap. range | 120 μF to 470 μF | | | |
| Capacitance tolerance | ±20 % (120 Hz / +20 °C) | | | |
| DC leakage current | I ≤ 0.1 CV (μA) 2 minutes | | | |
| Dissipation factor (tan δ) | ≤ 0.1 (120 Hz / + 20 °C) | | | |
| Surge voltage (V) | Rated voltage × 1.25 (15 °C to 35 °C) | | | |
| Endurance | +125 °C 5500 h, category voltage applied | | | |
| | Capacitance change | Within ±20 % of the initial value | | |
| | Dissipation factor (tan δ) | ≤ 2 times of the initial limit | | |
| | DC leakage current | ≤ 3 times of the initial limit | | |
| Damp heat (Steady state) | +85 °C, 85 % RH, 1000 h, No-applied voltage | | | |
| | Capacitance change of initial measured value | 2.0 V, 2.5 V | 4.0 V | 6.3 V |
| | | +70 %, -20 % | +60 %, -20 % | +50 %, -20 % |
| | Dissipation factor (tan δ) | ≤ 2 times of the initial limit | | |
| DC leakage current | ≤ 5 times of the initial limit | | | |

Marking

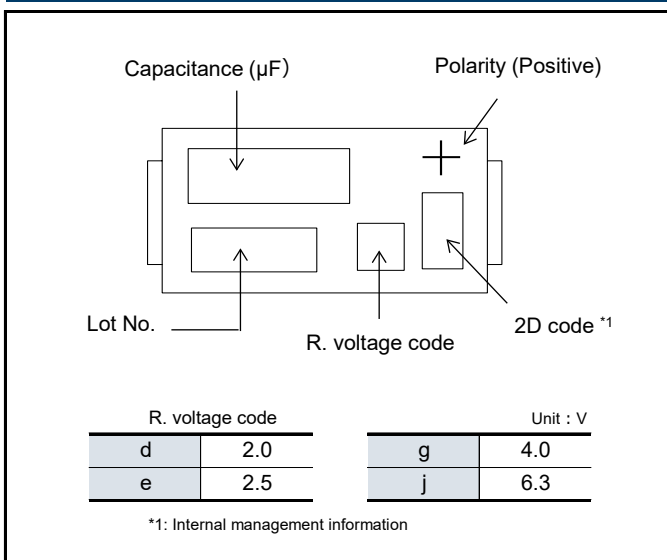

Dimensions (not to scale)

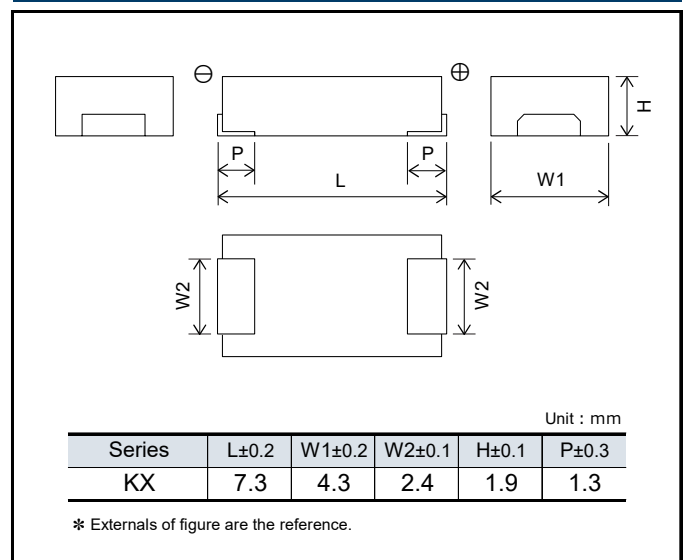

Explanation of part numbers

◆ Part number system e.g.: EEFKX0D331RE

| EEF | | KX | | 0D | | 331 | | | | RE | |
|--------|------------------------|--------|------|-------------------|------|------------------|------|------------------|------|----------|--------------|
| Series | Product classification | Series | Code | Rated Voltage (V) | Code | Capacitance (μF) | Code | Capacitance (μF) | Code | ESR (mΩ) | Special code |
| KX | EEF | KX | KX | 2.0 | 0D | 120 | 121 | 330 | 331 | 3 | RB |
| | | | | 2.5 | 0E | 150 | 151 | 390 | 391 | 4.5 | RC |
| | | | | 4.0 | 0G | 180 | 181 | 470 | 471 | 9 | RE |
| | | | | 6.3 | 0J | 220 | 221 | | | 15 | RF |

Characteristics list

| Series | Rated voltage [105 °C] (V) | Category voltage [125 °C] (V) | Capacitance (μF) | Case size (mm) | | | Specification | | Part number | Min. Packaging Qty (pcs) |
|--------|----------------------------|-------------------------------|------------------|----------------|-----|------|---------------------------|-----------------|--------------|--------------------------|
| | | | | L | W | H | Ripple current*1 (mA rms) | ESR*2 (mΩ max.) | | |
| KX | 2.0 | 1.6 | 330 | 7.3 | 4.3 | 1.9 | 6300 | 9 | EEFKX0D331RE | 3500 |
| | | | | 7.3 | 4.3 | 1.9 | 6300 | 9 | EEFKX0D471RE | 3500 |
| | | | 470 | 7.3 | 4.3 | 1.9 | 8500 | 4.5 | EEFKX0D471RC | 3500 |
| | | | | 7.3 | 4.3 | 1.9 | 10200 | 3 | EEFKX0D471RB | 3500 |
| | 2.5 | 2.0 | 220 | 7.3 | 4.3 | 1.9 | 6300 | 9 | EEFKX0E221RE | 3500 |
| | | | | 7.3 | 4.3 | 1.9 | 6300 | 9 | EEFKX0E331RE | 3500 |
| | | | 390 | 7.3 | 4.3 | 1.9 | 6300 | 9 | EEFKX0E391RE | 3500 |
| | | | | 7.3 | 4.3 | 1.9 | 8500 | 4.5 | EEFKX0E391RC | 3500 |
| | | | 470 | 7.3 | 4.3 | 1.9 | 10200 | 3 | EEFKX0E391RB | 3500 |
| | | | | 7.3 | 4.3 | 1.9 | 6300 | 9 | EEFKX0E471RE | 3500 |
| | | | | 7.3 | 4.3 | 1.9 | 8500 | 4.5 | EEFKX0E471RC | 3500 |
| | | | | 7.3 | 4.3 | 1.9 | 10200 | 3 | EEFKX0E471RB | 3500 |
| | 4.0 | 3.2 | 150 | 7.3 | 4.3 | 1.9 | 5100 | 15 | EEFKX0G151RF | 3500 |
| | | | 180 | 7.3 | 4.3 | 1.9 | 5100 | 15 | EEFKX0G181RF | 3500 |
| | | | 220 | 7.3 | 4.3 | 1.9 | 5100 | 15 | EEFKX0G221RF | 3500 |
| | 6.3 | 5.0 | 120 | 7.3 | 4.3 | 1.9 | 5100 | 15 | EEFKX0J121RF | 3500 |
| 150 | | | 7.3 | 4.3 | 1.9 | 5100 | 15 | EEFKX0J151RF | 3500 | |

*1: Ripple current (100 kHz / +45 °C)

*2: ESR (100 kHz / +20 °C)

◆ Please refer to each page in this catalog for "Reflow conditions" and "Taping specifications".

Temperature coefficient of ripple current

| Temperature | | T ≤ 45 °C | 45 °C < T ≤ 85 °C | 85 °C < T ≤ 125 °C |
|----------------|-------------|-----------|-------------------|--------------------|
| 2.0 V to 6.3 V | Coefficient | 1.0 | 0.7 | 0.25 |

◆ Ripple current should be controlled so that surface temperature of capacitor does not exceed the category temperature.

Conductive Polymer Aluminum Electrolytic Capacitors

Surface Mount Type

TX series [High temperature long life product]

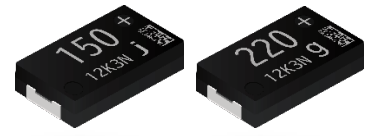

Notice: This product is not intended for use in automotive applications.

Features

- Endurance 135 °C 5500 h
- Damp heat 85°C 85% 1000 h
- Low ESR (3 ~ 15 mΩ max.)
- RoHS compliance, Halogen free

Specifications

| Series | TX | | | |
|----------------------------|--|-----------------------------------|--------------|--------------|
| Category temp. range | -55 °C to +135 °C | | | |
| Rated voltage range | 2.0 V to 6.3 V | | | |
| Category voltage range | 1.6 V, 2.0 V, 3.2 V, 5.0 V | | | |
| Rated cap. range | 120 μF to 470 μF | | | |
| Capacitance tolerance | ±20 % (120 Hz / +20 °C) | | | |
| DC leakage current | I ≤ 0.1 CV (μA) 2 minutes | | | |
| Dissipation factor (tan δ) | ≤ 0.1 (120 Hz / + 20 °C) | | | |
| Surge voltage (V) | Rated voltage × 1.25 (15 °C to 35 °C) | | | |
| Endurance | +135 °C 5500 h, category voltage applied | | | |
| | Capacitance change | Within ±20 % of the initial value | | |
| | Dissipation factor (tan δ) | ≤ 2 times of the initial limit | | |
| | DC leakage current | ≤ 3 times of the initial limit | | |
| Damp heat (Steady state) | +85 °C, 85 % RH, 1000 h, No-applied voltage | | | |
| | Capacitance change of initial measured value | 2.0 V, 2.5 V | 4.0 V | 6.3 V |
| | | +70 %, -20 % | +60 %, -20 % | +50 %, -20 % |
| | Dissipation factor (tan δ) | ≤ 2 times of the initial limit | | |
| DC leakage current | ≤ 5 times of the initial limit | | | |

Marking

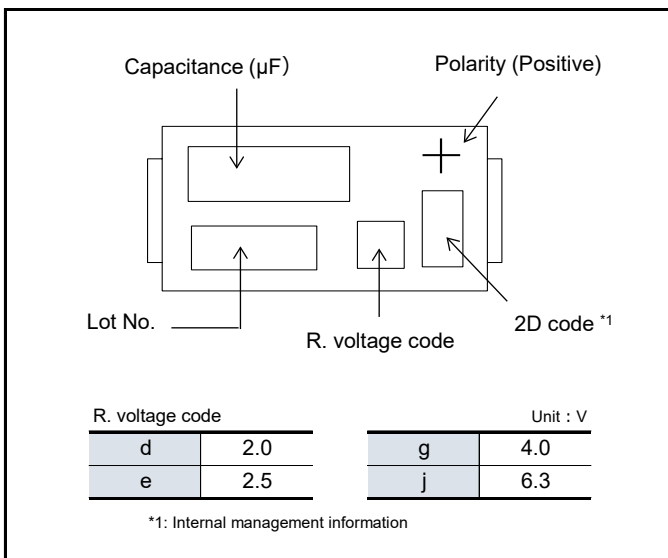

Dimensions (not to scale)

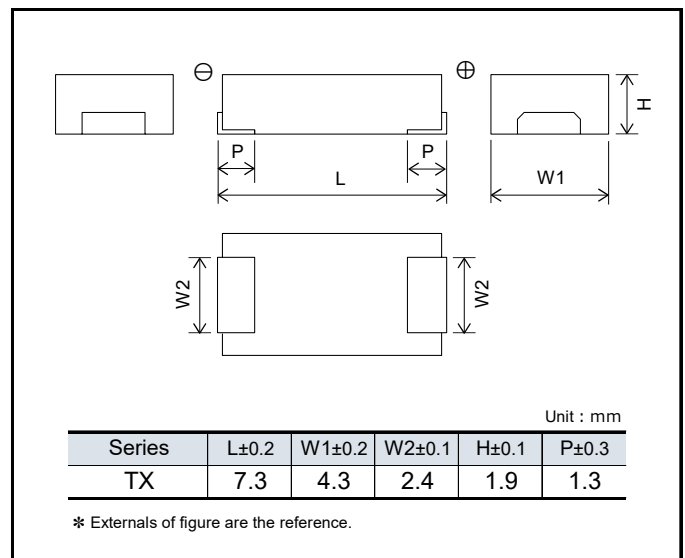

Explanation of part numbers

◇ Part number system e.g.: EEFTX0D331RE

| EEF | | TX | | 0D | | 331 | | RE | | | |
|--------|------------------------|--------|------|-------------------|------|------------------|------|------------------|------|----------|--------------|
| Series | Product classification | Series | Code | Rated Voltage (V) | Code | Capacitance (μF) | Code | Capacitance (μF) | Code | ESR (mΩ) | Special code |
| TX | EEF | TX | TX | 2.0 | 0D | 120 | 121 | 330 | 331 | 3 | RB |
| | | | | 2.5 | 0E | 150 | 151 | 390 | 391 | 4.5 | RC |
| | | | | 4.0 | 0G | 180 | 181 | 470 | 471 | 9 | RE |
| | | | | 6.3 | 0J | 220 | 221 | | | 15 | RF |

Characteristics list

| Series | Rated voltage [105 °C] (V) | Category voltage [135 °C] (V) | Capacitance (μF) | Case size (mm) | | | Specification | | Part number | Min. Packaging Qty (pcs) |
|--------|----------------------------|-------------------------------|------------------|----------------|-----|-----|---------------------------------------|-----------------------------|--------------|--------------------------|
| | | | | L | W | H | Ripple current* ¹ (mA rms) | ESR* ² (mΩ max.) | | |
| TX | 2.0 | 1.6 | 330 | 7.3 | 4.3 | 1.9 | 6300 | 9 | EEFTX0D331RE | 3500 |
| | | | | 7.3 | 4.3 | 1.9 | 6300 | 9 | EEFTX0D471RE | 3500 |
| | | | 470 | 7.3 | 4.3 | 1.9 | 8500 | 4.5 | EEFTX0D471RC | 3500 |
| | | | | 7.3 | 4.3 | 1.9 | 10200 | 3 | EEFTX0D471RB | 3500 |
| | 2.5 | 2.0 | 220 | 7.3 | 4.3 | 1.9 | 6300 | 9 | EEFTX0E221RE | 3500 |
| | | | | 7.3 | 4.3 | 1.9 | 6300 | 9 | EEFTX0E331RE | 3500 |
| | | | 390 | 7.3 | 4.3 | 1.9 | 6300 | 9 | EEFTX0E391RE | 3500 |
| | | | | 7.3 | 4.3 | 1.9 | 8500 | 4.5 | EEFTX0E391RC | 3500 |
| | | | | 7.3 | 4.3 | 1.9 | 10200 | 3 | EEFTX0E391RB | 3500 |
| | 4.0 | 3.2 | 150 | 7.3 | 4.3 | 1.9 | 5100 | 15 | EEFTX0G151RF | 3500 |
| | | | 180 | 7.3 | 4.3 | 1.9 | 5100 | 15 | EEFTX0G181RF | 3500 |
| | | | 220 | 7.3 | 4.3 | 1.9 | 5100 | 15 | EEFTX0G221RF | 3500 |
| | 6.3 | 5.0 | 120 | 7.3 | 4.3 | 1.9 | 5100 | 15 | EEFTX0J121RF | 3500 |
| | | | 150 | 7.3 | 4.3 | 1.9 | 5100 | 15 | EEFTX0J151RF | 3500 |

*1: Ripple current (100 kHz / +45 °C)

*2: ESR (100 kHz / +20 °C)

◆ Please refer to each page in this catalog for "Reflow conditions" and "Taping specifications".

Temperature coefficient of ripple current

| Temperature | | T ≤ 45 °C | 45 °C < T ≤ 85 °C | 85 °C < T ≤ 135 °C |
|----------------|-------------|-----------|-------------------|--------------------|
| 2.0 V to 6.3 V | Coefficient | 1.0 | 0.7 | 0.25 |

◆ Ripple current should be controlled so that surface temperature of capacitor does not exceed the category temperature.

Conductive Polymer Aluminum Electrolytic Capacitors

Surface Mount Type

JZ series [High temperature long life product]



Notice: This product is not intended for use in automotive applications.

Features

- Endurance 125 °C 3000 h
- Damp heat 85°C 85% 1000 h
- Low ESR (3 to 9 mΩ)
- RoHS compliance, Halogen free

Specifications

| | | |
|----------------------------|--|-----------------------------------|
| Series | JZ | |
| Category temp. range | -55 °C to +125 °C | |
| Rated voltage range | 2.0 V | |
| Category voltage range | 1.6 V | |
| Rated cap. range | 560 μF | |
| Capacitance tolerance | ±20 % (120 Hz / +20 °C) | |
| DC leakage current | I ≤ 0.1 CV (μA) 2 minutes | |
| Dissipation factor (tan δ) | ≤ 0.1 (120 Hz / + 20 °C) | |
| Surge voltage (V) | Rated voltage × 1.25 (15 °C to 35 °C) | |
| Endurance | +125 °C 3000 h, category voltage applied | |
| | Capacitance change | Within ±20 % of the initial value |
| | Dissipation factor (tan δ) | ≤ 2 times of the initial limit |
| | DC leakage current | ≤ 3 times of the initial limit |
| Damp heat (Steady state) | +85 °C, 85 % RH, 1000 h, No-applied voltage | |
| | Capacitance change of initial measured value | 2.0 V |
| | | +70 %, -20 % |
| | Dissipation factor (tan δ) | ≤ 2 times of the initial limit |
| DC leakage current | ≤ 5 times of the initial limit | |

Marking

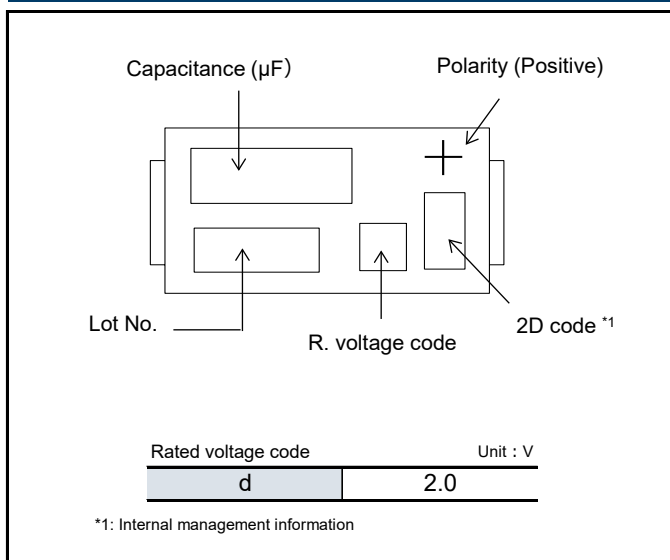

Dimensions (not to scale)

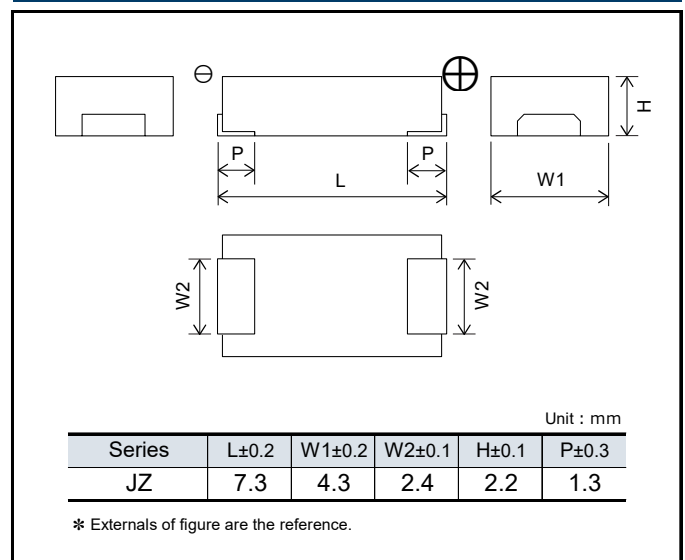

Explanation of part numbers

◇ Part number system e.g.: EEFJZ0D561RE

| EEF | | JZ | | 0D | | 561 | | RE | |
|--------|------------------------|--------|------|-------------------|------|------------------|------|----------|--------------|
| Series | Product classification | Series | Code | Rated Voltage (V) | Code | Capacitance (μF) | Code | ESR (mΩ) | Special code |
| JZ | EEF | JZ | JZ | 2.0 | 0D | 560 | 561 | 3 | RB |
| | | | | | | | | 4.5 | RC |
| | | | | | | | | 9 | RE |

Characteristics list

| Series | Rated voltage [105 °C] (V) | Category voltage [125 °C] (V) | Capacitance (μF) | Case size (mm) | | | Specification | | Part number | Min. Packaging Q'ty (pcs) |
|--------|----------------------------|-------------------------------|------------------|----------------|-----|-----|---------------------------------------|-----------------------------|--------------|---------------------------|
| | | | | L | W | H | Ripple current* ¹ (mA rms) | ESR* ² (mΩ max.) | | |
| JZ | 2.0 | 1.6 | 560 | 7.3 | 4.3 | 2.2 | 6300 | 9 | EEFJZ0D561RE | 3000 |
| | | | | 7.3 | 4.3 | 2.2 | 8500 | 4.5 | EEFJZ0D561RC | 3000 |
| | | | | 7.3 | 4.3 | 2.2 | 10200 | 3 | EEFJZ0D561RB | 3000 |

*1: Ripple current (100 kHz / +45 °C)

*2: ESR (100 kHz / +20 °C)

◆ Please refer to each page in this catalog for "Reflow conditions" and "Taping specifications".

Temperature coefficient of ripple current

| Temperature | | T ≤ 45 °C | 45 °C < T ≤ 85 °C | 85 °C < T ≤ 125 °C |
|-------------|-------------|-----------|-------------------|--------------------|
| 2.0 V | Coefficient | 1.0 | 0.7 | 0.25 |

◆ Ripple current should be controlled so that surface temperature of capacitor does not exceed the category temperature.

**Conductive Polymer Aluminum
Electrolytic Capacitors**
Surface Mount Type

KZ series [High temperature long life product]



Notice: This product is not intended for use in automotive applications.

Features

- Endurance 125 °C 5500 h
- Damp heat 85°C 85% 1000 h
- Low ESR (3 to 9 mΩ)
- RoHS compliance, Halogen free

Specifications

| | | |
|----------------------------|--|-----------------------------------|
| Series | KZ | |
| Category temp. range | -55 °C to +125 °C | |
| Rated voltage range | 2.0 V | |
| Category voltage range | 1.6 V | |
| Rated cap. range | 560 μF | |
| Capacitance tolerance | ±20 % (120 Hz / +20 °C) | |
| DC leakage current | I ≤ 0.1 CV (μA) 2 minutes | |
| Dissipation factor (tan δ) | ≤ 0.1 (120 Hz / + 20 °C) | |
| Surge voltage (V) | Rated voltage × 1.25 (15 °C to 35 °C) | |
| Endurance | +125 °C 5500 h, category voltage applied | |
| | Capacitance change | Within ±20 % of the initial value |
| | Dissipation factor (tan δ) | ≤ 2 times of the initial limit |
| | DC leakage current | ≤ 3 times of the initial limit |
| Damp heat (Steady state) | +85 °C, 85 % RH, 1000 h, No-applied voltage | |
| | Capacitance change of initial measured value | 2.0 V +70 %, -20 % |
| | Dissipation factor (tan δ) | ≤ 2 times of the initial limit |
| | DC leakage current | ≤ 5 times of the initial limit |

Marking

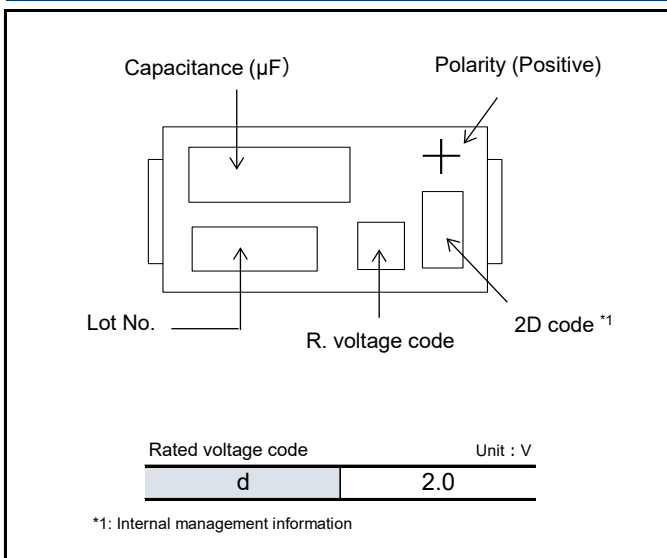

Dimensions (not to scale)

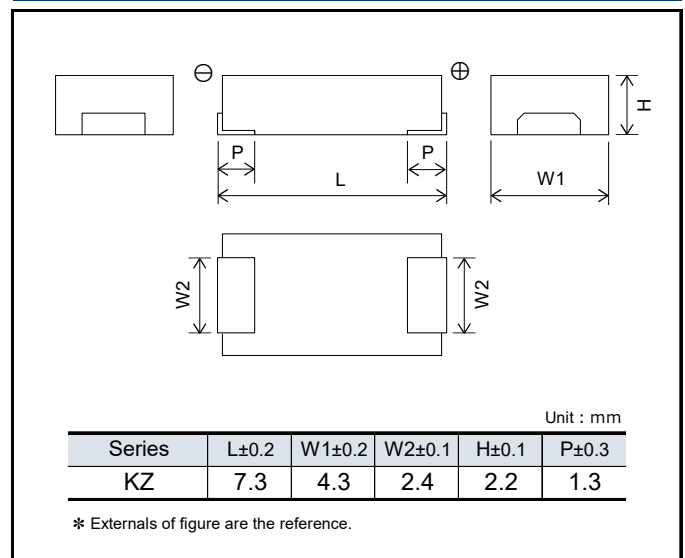

Explanation of part numbers

◇ Part number system e.g.: EEFKZ0D561RE

| EEF | | KZ | | 0D | | 561 | | RE | |
|--------|------------------------|--------|------|-------------------|------|------------------|------|----------|--------------|
| Series | Product classification | Series | Code | Rated Voltage (V) | Code | Capacitance (μF) | Code | ESR (mΩ) | Special code |
| KZ | EEF | KZ | KZ | 2.0 | 0D | 560 | 561 | 3 | RB |
| | | | | | | | | 4.5 | RC |
| | | | | | | | | 9 | RE |

Characteristics list

| Series | Rated voltage [105 °C] (V) | Category voltage [125 °C] (V) | Capacitance (μF) | Case size (mm) | | | Specification | | Part number | Min. Packaging Q'ty (pcs) |
|--------|----------------------------|-------------------------------|------------------|----------------|-----|-----|---------------------------------------|-----------------------------|--------------|---------------------------|
| | | | | L | W | H | Ripple current* ¹ (mA rms) | ESR* ² (mΩ max.) | | |
| KZ | 2.0 | 1.6 | 560 | 7.3 | 4.3 | 2.2 | 6300 | 9 | EEFKZ0D561RE | 3000 |
| | | | | 7.3 | 4.3 | 2.2 | 8500 | 4.5 | EEFKZ0D561RC | 3000 |
| | | | | 7.3 | 4.3 | 2.2 | 10200 | 3 | EEFKZ0D561RB | 3000 |

*1: Ripple current (100 kHz / +45 °C)

*2: ESR (100 kHz / +20 °C)

◆ Please refer to each page in this catalog for "Reflow conditions" and "Taping specifications".

Temperature coefficient of ripple current

| Temperature | | T ≤ 45 °C | 45 °C < T ≤ 85 °C | 85 °C < T ≤ 125 °C |
|-------------|-------------|-----------|-------------------|--------------------|
| 2.0 V | Coefficient | 1.0 | 0.7 | 0.25 |

◆ Ripple current should be controlled so that surface temperature of capacitor does not exceed the category temperature.

Conductive Polymer Aluminum Electrolytic Capacitors

Surface Mount Type

TZ series [High temperature long life product]

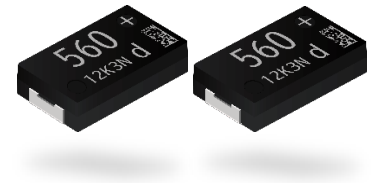

Notice: This product is not intended for use in automotive applications.

Features

- Endurance 135 °C 5500 h
- Damp heat 85°C 85% 1000 h
- Low ESR (3 to 9 mΩ)
- RoHS compliance, Halogen free

Specifications

| | | |
|----------------------------|--|-----------------------------------|
| Series | TZ | |
| Category temp. range | -55 °C to +135 °C | |
| Rated voltage range | 2.0 V | |
| Category voltage range | 1.6 V | |
| Rated cap. range | 560 μF | |
| Capacitance tolerance | ±20 % (120 Hz / +20 °C) | |
| DC leakage current | I ≤ 0.1 CV (μA) 2 minutes | |
| Dissipation factor (tan δ) | ≤ 0.1 (120 Hz / + 20 °C) | |
| Surge voltage (V) | Rated voltage × 1.25 (15 °C to 35 °C) | |
| Endurance | +135 °C 5500 h, category voltage applied | |
| | Capacitance change | Within ±20 % of the initial value |
| | Dissipation factor (tan δ) | ≤ 2 times of the initial limit |
| | DC leakage current | ≤ 3 times of the initial limit |
| Damp heat (Steady state) | +85 °C, 85 % RH, 1000 h, No-applied voltage | |
| | Capacitance change of initial measured value | 2.0 V |
| | | +70 %, -20 % |
| | Dissipation factor (tan δ) | ≤ 2 times of the initial limit |
| DC leakage current | ≤ 5 times of the initial limit | |

Marking

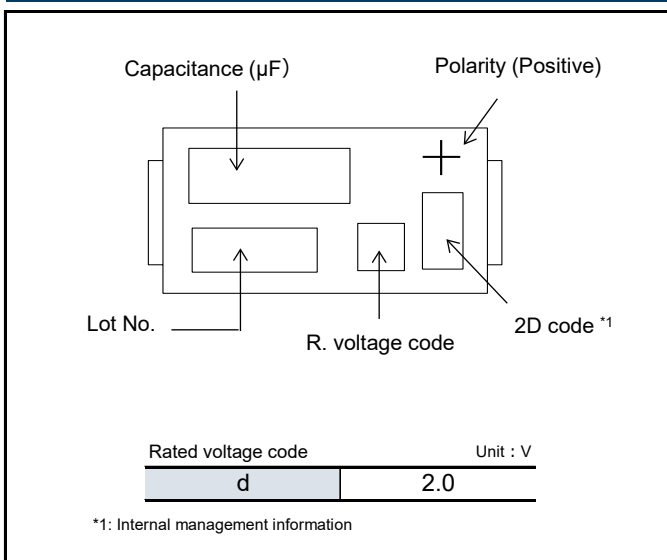

Dimensions (not to scale)

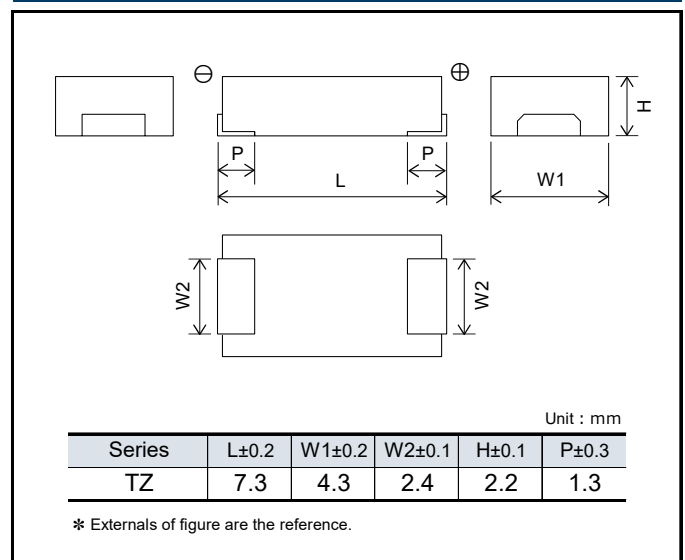

Explanation of part numbers

◇ Part number system e.g.: EEFTZ0D561RE

| EEF | | TZ | | 0D | | 561 | | RE | |
|--------|------------------------|--------|------|-------------------|------|------------------|------|----------|--------------|
| Series | Product classification | Series | Code | Rated Voltage (V) | Code | Capacitance (μF) | Code | ESR (mΩ) | Special code |
| TZ | EEF | TZ | TZ | 2.0 | 0D | 560 | 561 | 3 | RB |
| | | | | | | | | 4.5 | RC |
| | | | | | | | | 9 | RE |

Characteristics list

| Series | Rated voltage [105 °C] (V) | Category voltage [135 °C] (V) | Capacitance (μF) | Case size (mm) | | | Specification | | Part number | Min. Packaging Q'ty (pcs) |
|--------|----------------------------|-------------------------------|------------------|----------------|-----|-----|---------------------------|-----------------|--------------|---------------------------|
| | | | | L | W | H | Ripple current*1 (mA rms) | ESR*2 (mΩ max.) | | |
| TZ | 2.0 | 1.6 | 560 | 7.3 | 4.3 | 2.2 | 6300 | 9 | EEFTZ0D561RE | 3000 |
| | | | | 7.3 | 4.3 | 2.2 | 8500 | 4.5 | EEFTZ0D561RC | 3000 |
| | | | | 7.3 | 4.3 | 2.2 | 10200 | 3 | EEFTZ0D561RB | 3000 |

*1: Ripple current (100 kHz / +45 °C)

*2: ESR (100 kHz / +20 °C)

◆ Please refer to each page in this catalog for "Reflow conditions" and "Taping specifications".

Temperature coefficient of ripple current

| Temperature | | T ≤ 45 °C | 45 °C < T ≤ 85 °C | 85 °C < T ≤ 135 °C |
|-------------|-------------|-----------|-------------------|--------------------|
| 2.0 V | Coefficient | 1.0 | 0.7 | 0.25 |

◆ Ripple current should be controlled so that surface temperature of capacitor does not exceed the category temperature.

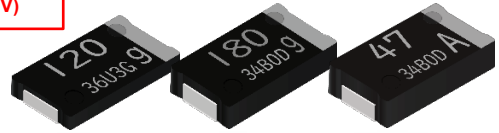

Conductive Polymer Aluminum Electrolytic Capacitors

Surface Mount Type

CS/CT/CX series

When SP-Cap is designed to be used under constant high load application such as represented in but not limited to the following products such as AI servers, switches, routers, and base stations, we strongly recommend using the long-life series (JX/KX/TX series) and avoid choosing standard series (CS/CT/CX series).

Notice: This product is not intended for use in automotive applications.

Features

- High voltage (35 V max.)
- Low profile (Height 1.0 mm max.)
- High ripple current (5600 mA rms max.)
- RoHS compliance, Halogen free

Specifications

| Series | CS | CT | CX | |
|----------------------------|--|--|-------------------------------------|-----------------------|
| Category temp. range | -55 °C to +105 °C | | | |
| Rated voltage range | 4.0 V to 35 V | | 2.0 V to 35 V | |
| Rated cap. range | 10 µF to 120 µF | 15 µF to 180 µF | 15 µF to 560 µF | |
| Capacitance tolerance | ±20 % (120 Hz / +20 °C) | | | |
| DC leakage current | I ≤ 0.1 CV(µA) [2.0 V to 6.3 V, 2 min], I ≤ 0.3 CV(µA) [10 V to 35 V, 2 min] | | | |
| Dissipation factor (tan δ) | ≤ 0.06 (120 Hz / + 20 °C) | | | |
| Surge voltage (V) | Rated voltage × 1.25 [2.0 V to 16 V], × 1.15 [20 V to 35 V] (15 °C to 35 °C) | | | |
| Endurance | +105 °C 2000 h, rated voltage applied | | | |
| | Capacitance change | Within ±20 % of the initial value | | |
| | Dissipation factor (tan δ) | ≤ 2 times of the initial limit | | |
| | DC leakage current | ≤ 3 times of the initial limit : 2.0 V to 6.3 V Within the initial limit : 10 V to 35 V | | |
| Damp heat (Steady state) | +60 °C, 90 % RH, 500 h, No-applied voltage | | | |
| | Capacitance change of initial measurd value | 2.0 V to 2.5 V +70 %, -20 % | 4.0 V, 10 V to 35 V +60 %, -20 % | 6.3 V +50 %, -20 % |
| | Dissipation factor (tan δ) | ≤ 2 times of the initial limit | | |
| | DC leakage current | Within the initial limit : 2.0 V to 6.3 V ≤ 3 times of the initial limit : 10 V to 35 V | | |

Marking

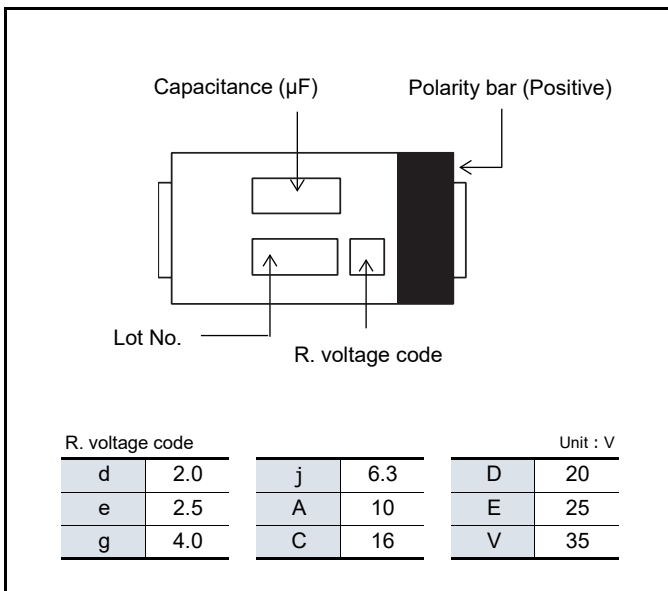

Dimensions (not to scale)

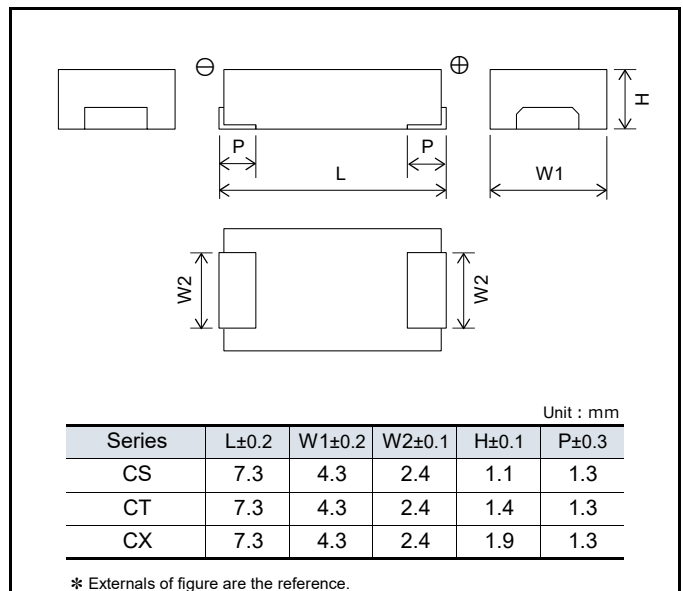

Explanation of part numbers

◇ Part number system e.g.: EEFC0G121R

| EEF | | CS | | 0G | | 121 | | R | | | |
|--------|------------------------|--------|------|-------------------|------|------------------|------|------------------|------|--------------------------------------|--------------|
| Series | Product classification | Series | Code | Rated Voltage (V) | Code | Capacitance (μF) | Code | Capacitance (μF) | Code | ESR (mΩ) | Special code |
| CS | EEF | CS | CS | 2.0 | 0D | 10 | 100 | 150 | 151 | 15 (2.0 to 6.3 V) 40 (10 to 35 V) | R |
| CT | | CT | 2.5 | 0E | 15 | 150 | 180 | 181 | | | |
| CX | | CX | CX | 4.0 | 0G | 22 | 220 | 220 | 221 | | |
| | | | | 6.3 | 0J | 33 | 330 | 270 | 271 | 12 | XR |
| | | | | 10 | 1A | 47 | 470 | 330 | 331 | | |
| | | | | 16 | 1C | 56 | 560 | 390 | 391 | | |
| | | | | 20 | 1D | 68 | 680 | 470 | 471 | | |
| | | | | 25 | 1E | 100 | 101 | 560 | 561 | | |
| | | | | 35 | 1V | 120 | 121 | | | | |

Characteristics list

■ 2.0 V to 6.3 V

| Series | Rated voltage (V) | Capacitance (μF) | Case size (mm) | | | Specification | | Part number | Min. Packaging Qty (pcs) |
|--------|-------------------|------------------|----------------|-----|------|---------------------------------------|-----------------------------|-------------|--------------------------|
| | | | L | W | H | Ripple current ^{*1} (mA rms) | ESR ^{*2} (mΩ max.) | | |
| CS | 4.0 | 120 | 7.3 | 4.3 | 1.1 | 5100 | 15 | EEFC0G121R | 3500 |
| | 6.3 | 68 | 7.3 | 4.3 | 1.1 | 5100 | 15 | EEFC0J680R | 3500 |
| CT | 4.0 | 180 | 7.3 | 4.3 | 1.4 | 5100 | 15 | EEFC0G181R | 3500 |
| | 6.3 | 100 | 7.3 | 4.3 | 1.4 | 5100 | 15 | EEFC0J101R | 3500 |
| CX | 2.0 | 220 | 7.3 | 4.3 | 1.9 | 5100 | 15 | EEFC0D221R | 3500 |
| | | 270 | 7.3 | 4.3 | 1.9 | 5600 | 12 | EEFC0D271XR | 3500 |
| | | 330 | 7.3 | 4.3 | 1.9 | 5100 | 15 | EEFC0D331R | 3500 |
| | | | 7.3 | 4.3 | 1.9 | 5600 | 12 | EEFC0D331XR | 3500 |
| | | 390 | 7.3 | 4.3 | 1.9 | 5100 | 15 | EEFC0D391R | 3500 |
| | | 470 | 7.3 | 4.3 | 1.9 | 5100 | 15 | EEFC0D471R | 3500 |
| | 560 | 7.3 | 4.3 | 1.9 | 5100 | 15 | EEFC0D561R | 3500 | |
| | 2.5 | 220 | 7.3 | 4.3 | 1.9 | 5100 | 15 | EEFC0E221R | 3500 |
| | | 330 | 7.3 | 4.3 | 1.9 | 5100 | 15 | EEFC0E331R | 3500 |
| | | 390 | 7.3 | 4.3 | 1.9 | 5100 | 15 | EEFC0E391R | 3500 |
| | | 470 | 7.3 | 4.3 | 1.9 | 5100 | 15 | EEFC0E471R | 3500 |
| | 4.0 | 150 | 7.3 | 4.3 | 1.9 | 5100 | 15 | EEFC0G151R | 3500 |
| | | | 7.3 | 4.3 | 1.9 | 5100 | 15 | EEFC0G181R | 3500 |
| | | 180 | 7.3 | 4.3 | 1.9 | 5600 | 12 | EEFC0G181XR | 3500 |
| | | | 7.3 | 4.3 | 1.9 | 5100 | 15 | EEFC0G221R | 3500 |
| | | 220 | 7.3 | 4.3 | 1.9 | 5600 | 12 | EEFC0G221XR | 3500 |
| | | | 7.3 | 4.3 | 1.9 | 5100 | 15 | EEFC0G271R | 3500 |
| | | 330 | 7.3 | 4.3 | 1.9 | 5100 | 15 | EEFC0G331R | 3500 |
| | | 6.3 | 100 | 7.3 | 4.3 | 1.9 | 5100 | 15 | EEFC0J101R |
| | 120 | | 7.3 | 4.3 | 1.9 | 5100 | 15 | EEFC0J121R | 3500 |
| 150 | 7.3 | | 4.3 | 1.9 | 5100 | 15 | EEFC0J151R | 3500 | |
| | 7.3 | | 4.3 | 1.9 | 5600 | 12 | EEFC0J151XR | 3500 | |
| 180 | 7.3 | | 4.3 | 1.9 | 5100 | 15 | EEFC0J181R | 3500 | |
| 220 | 7.3 | | 4.3 | 1.9 | 5100 | 15 | EEFC0J221R | 3500 | |

*1: Ripple current (100 kHz / +45 °C)

*2: ESR (100 kHz / +20 °C)

◆ Please refer to each page in this catalog for "Reflow conditions" and "Taping specifications".

Temperature coefficient of ripple current

| Temperature | | T ≤ 45 °C | 45 °C < T ≤ 85 °C | 85 °C < T ≤ 105 °C |
|----------------|-------------|-----------|-------------------|--------------------|
| 2.0 V to 6.3 V | Coefficient | 1.0 | 0.7 | 0.25 |

◆ Ripple current should be controlled so that surface temperature of capacitor does not exceed the category temperature.

Characteristics list

■ 10 V to 35 V

Not Recommended for New Design

For replacement

| Series | Rated voltage (V) | Capacitance (μF) | Case size (mm) | | | Specification | | Part number | Min. Packaging Qty (pcs) |
|--------|-------------------|------------------|----------------|-----|-----|---------------------------------------|-----------------------------|-------------|--------------------------|
| | | | L | W | H | Ripple current ^{*1} (mA rms) | ESR ^{*2} (mΩ max.) | | |
| CS | 10 | 47 | 7.3 | 4.3 | 1.1 | 3200 | 40 | EEFCS1A470R | 3500 |
| | 16 | 15 | 7.3 | 4.3 | 1.1 | 3200 | 40 | EEFCS1C150R | 3500 |
| | | 22 | 7.3 | 4.3 | 1.1 | 3200 | 40 | EEFCS1C220R | 3500 |
| | | 33 | 7.3 | 4.3 | 1.1 | 3200 | 40 | EEFCS1C330R | 3500 |
| | 20 | 10 | 7.3 | 4.3 | 1.1 | 3200 | 40 | EEFCS1D100R | 3500 |
| | | 15 | 7.3 | 4.3 | 1.1 | 3200 | 40 | EEFCS1D150R | 3500 |
| | | 22 | 7.3 | 4.3 | 1.1 | 3200 | 40 | EEFCS1D220R | 3500 |
| | 25 | 10 | 7.3 | 4.3 | 1.1 | 3200 | 40 | EEFCS1E100R | 3500 |
| | | 15 | 7.3 | 4.3 | 1.1 | 3200 | 40 | EEFCS1E150R | 3500 |
| | 35 | 10 | 7.3 | 4.3 | 1.1 | 3200 | 40 | EEFCS1V100R | 3500 |
| CT | 10 | 68 | 7.3 | 4.3 | 1.4 | 3200 | 40 | EEFCT1A680R | 3500 |
| | 16 | 47 | 7.3 | 4.3 | 1.4 | 3200 | 40 | EEFCT1C470R | 3500 |
| | | 33 | 7.3 | 4.3 | 1.4 | 3200 | 40 | EEFCT1D330R | 3500 |
| | 20 | 47 | 7.3 | 4.3 | 1.4 | 3200 | 40 | EEFCT1D470R | 3500 |
| | | 22 | 7.3 | 4.3 | 1.4 | 3200 | 40 | EEFCT1E220R | 3500 |
| | 35 | 15 | 7.3 | 4.3 | 1.4 | 3200 | 40 | EEFCT1V150R | 3500 |
| CX | 10 | 47 | 7.3 | 4.3 | 1.9 | 3200 | 40 | EEFCX1A470R | 3500 |
| | | 68 | 7.3 | 4.3 | 1.9 | 3200 | 40 | EEFCX1A680R | 3500 |
| | | 100 | 7.3 | 4.3 | 1.9 | 3200 | 40 | EEFCX1A101R | 3500 |
| | 16 | 15 | 7.3 | 4.3 | 1.9 | 3200 | 40 | EEFCX1C150R | 3500 |
| | | 22 | 7.3 | 4.3 | 1.9 | 3200 | 40 | EEFCX1C220R | 3500 |
| | | 33 | 7.3 | 4.3 | 1.9 | 3200 | 40 | EEFCX1C330R | 3500 |
| | | 47 | 7.3 | 4.3 | 1.9 | 3200 | 40 | EEFCX1C470R | 3500 |
| | | 68 | 7.3 | 4.3 | 1.9 | 3200 | 40 | EEFCX1C680R | 3500 |
| | | 22 | 7.3 | 4.3 | 1.9 | 3200 | 40 | EEFCX1D220R | 3500 |
| | 20 | 33 | 7.3 | 4.3 | 1.9 | 3200 | 40 | EEFCX1D330R | 3500 |
| | | 47 | 7.3 | 4.3 | 1.9 | 3200 | 40 | EEFCX1D470R | 3500 |
| | | 56 | 7.3 | 4.3 | 1.9 | 3200 | 40 | EEFCX1D560R | 3500 |
| | | 15 | 7.3 | 4.3 | 1.9 | 3200 | 40 | EEFCX1E150R | 3500 |
| | 25 | 22 | 7.3 | 4.3 | 1.9 | 3200 | 40 | EEFCX1E220R | 3500 |
| | | 33 | 7.3 | 4.3 | 1.9 | 3200 | 40 | EEFCX1E330R | 3500 |
| | | 15 | 7.3 | 4.3 | 1.9 | 3200 | 40 | EEFCX1V150R | 3500 |
| | 35 | 22 | 7.3 | 4.3 | 1.9 | 3200 | 40 | EEFCX1V220R | 3500 |

*1: Ripple current (100 kHz / +45 °C)

*2: ESR (100 kHz / +20 °C)

◆ Please refer to each page in this catalog for "Reflow conditions" and "Taping specifications".

Temperature coefficient of ripple current

| Temperature | | T ≤ 45 °C | 45 °C < T ≤ 85 °C | 85 °C < T ≤ 105 °C |
|--------------|-------------|-----------|-------------------|--------------------|
| 10 V to 35 V | Coefficient | 1.0 | 0.8 | 0.5 |

◆ Ripple current should be controlled so that surface temperature of capacitor does not exceed the category temperature.

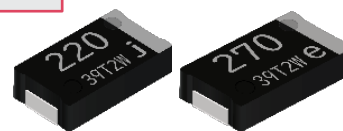

Conductive Polymer Aluminum Electrolytic Capacitors

Surface Mount Type

SX series [Low ESR products]

When SP-Cap is designed to be used under constant high load application such as represented in but not limited to the following products such as AI servers, switches, routers, and base stations, we strongly recommend using the long-life series (JX/KX/TX series) and avoid choosing standard series (SX series).

Notice: This product is not intended for use in automotive applications.

Features

- Large capacitance (560 μ F max.)
- Low ESR (4.5 m Ω to 9 m Ω max.)
- High ripple current (8500 mA rms max.)
- RoHS compliance, Halogen free

Specifications

| Series | SX | | | |
|------------------------------------|--|--|--------------|--------------|
| Category temp. range | -55 °C to +105 °C | | | |
| Rated voltage range | 2.0 V to 6.3 V | | | |
| Rated cap. range | 82 μ F to 560 μ F | | | |
| Capacitance tolerance | \pm 20 % (120 Hz / +20 °C) | | | |
| DC leakage current | $I \leq 0.1 CV$ (μ A) 2 minutes | | | |
| Dissipation factor (tan δ) | ≤ 0.06 (120 Hz / +20 °C) | | | |
| Surge voltage (V) | Rated voltage \times 1.25 (15 °C to 35 °C) | | | |
| Endurance | +105 °C 2000 h, rated voltage applied | | | |
| | Capacitance change | Within \pm 20 % of the initial value | | |
| | Dissipation factor (tan δ) | ≤ 2 times of the initial limit | | |
| | DC leakage current | ≤ 3 times of the initial limit | | |
| Damp heat (Steady state) | +60 °C, 90 % RH, 500 h, No-applied voltage | | | |
| | Capacitance change of initial measurd value | 2.0 V to 2.5 V | 4.0 V | 6.3 V |
| | | +70 %, -20 % | +60 %, -20 % | +50 %, -20 % |
| | Dissipation factor (tan δ) | ≤ 2 times of the initial limit | | |
| DC leakage current | Within the initial limit | | | |

Marking

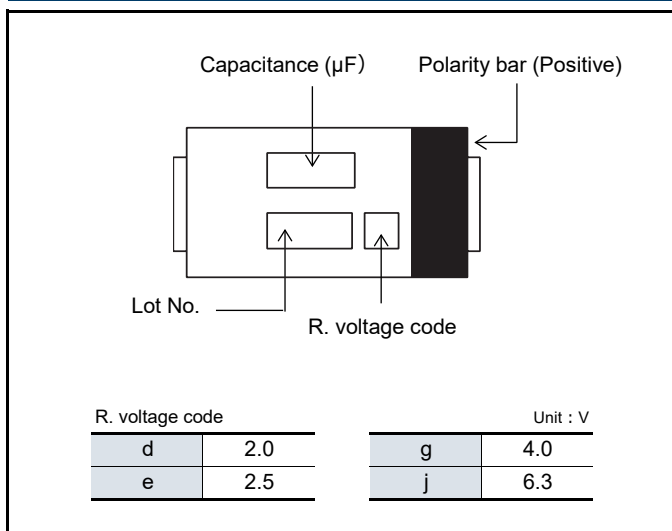

Dimensions (not to scale)

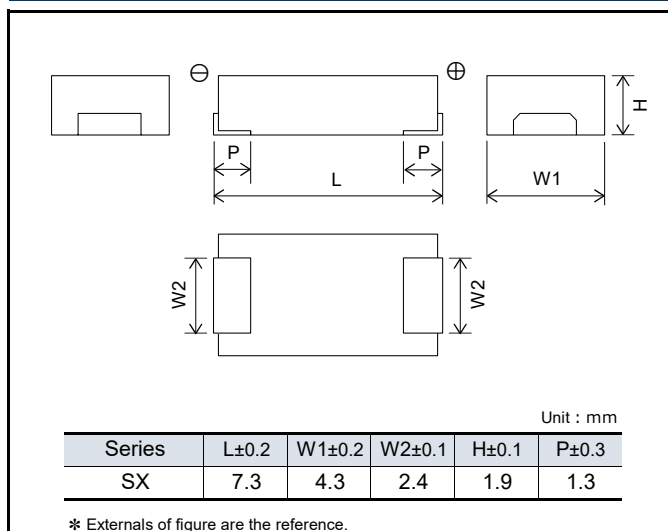

Explanation of part numbers

◆ Part number system e.g.: EEFSX0D271XE

| EEF | | SX | | OD | | 271 | | XE | | | |
|--------|------------------------|--------|------|-------------------|------|------------------|------|------------------|------|----------|--------------|
| Series | Product classification | Series | Code | Rated Voltage (V) | Code | Capacitance (μF) | Code | Capacitance (μF) | Code | ESR (mΩ) | Special code |
| SX | EEF | SX | SX | 2.0 | OD | 82 | 820 | 270 | 271 | 4.5 | E4 |
| | | | | 2.5 | OE | 100 | 101 | 330 | 331 | 6 | XE |
| | | | | 4.0 | OG | 120 | 121 | 390 | 391 | 7 | E7 |
| | | | | 6.3 | OJ | 150 | 151 | 470 | 471 | 9 | ER |
| | | | | | | 180 | 181 | 560 | 561 | | |
| | | | | | | 220 | 221 | | | | |

Characteristics list

| Series | Rated voltage (V) | Capacitance (μF) | Case size (mm) | | | Specification | | Part number | Min. Packaging Qty (pcs) | | |
|--------|-------------------|------------------|----------------|-----|------|---------------------------------------|-----------------------------|--------------|--------------------------|--------------|------|
| | | | L | W | H | Ripple current* ¹ (mA rms) | ESR* ² (mΩ max.) | | | | |
| SX | 2.0 | 180 | 7.3 | 4.3 | 1.9 | 6300 | 9 | EEFSX0D181ER | 3500 | | |
| | | 220 | 7.3 | 4.3 | 1.9 | 6300 | 9 | EEFSX0D221ER | 3500 | | |
| | | 270 | 7.3 | 4.3 | 1.9 | 6300 | 9 | EEFSX0D271ER | 3500 | | |
| | | | 7.3 | 4.3 | 1.9 | 7500 | 6 | EEFSX0D271XE | 3500 | | |
| | | 330 | 7.3 | 4.3 | 1.9 | 8500 | 4.5 | EEFSX0D271E4 | 3500 | | |
| | | | 7.3 | 4.3 | 1.9 | 6300 | 9 | EEFSX0D331ER | 3500 | | |
| | | | 7.3 | 4.3 | 1.9 | 7500 | 6 | EEFSX0D331XE | 3500 | | |
| | | 390 | 7.3 | 4.3 | 1.9 | 8500 | 4.5 | EEFSX0D331E4 | 3500 | | |
| | | | 7.3 | 4.3 | 1.9 | 6300 | 9 | EEFSX0D391ER | 3500 | | |
| | | | 7.3 | 4.3 | 1.9 | 7500 | 6 | EEFSX0D391XE | 3500 | | |
| | | 470 | 7.3 | 4.3 | 1.9 | 8500 | 4.5 | EEFSX0D391E4 | 3500 | | |
| | | | 7.3 | 4.3 | 1.9 | 6300 | 9 | EEFSX0D471ER | 3500 | | |
| | | | 7.3 | 4.3 | 1.9 | 7500 | 6 | EEFSX0D471XE | 3500 | | |
| | | | | 7.3 | 4.3 | 1.9 | 8500 | 4.5 | EEFSX0D471E4 | 3500 | |
| | | | | 560 | 7.3 | 4.3 | 1.9 | 8500 | 4.5 | EEFSX0D561E4 | 3500 |
| | | 2.5 | 150 | 7.3 | 4.3 | 1.9 | 6300 | 9 | EEFSX0E151ER | 3500 | |
| | | | 180 | 7.3 | 4.3 | 1.9 | 6300 | 9 | EEFSX0E181ER | 3500 | |
| | | | 220 | 7.3 | 4.3 | 1.9 | 6300 | 9 | EEFSX0E221ER | 3500 | |
| | 7.3 | | | 4.3 | 1.9 | 7000 | 7 | EEFSX0E221E7 | 3500 | | |
| | 270 | | 7.3 | 4.3 | 1.9 | 7000 | 7 | EEFSX0E271E7 | 3500 | | |
| | | | 7.3 | 4.3 | 1.9 | 6300 | 9 | EEFSX0E331ER | 3500 | | |
| | 330 | | 7.3 | 4.3 | 1.9 | 7500 | 6 | EEFSX0E331XE | 3500 | | |
| | | | 7.3 | 4.3 | 1.9 | 8500 | 4.5 | EEFSX0E331E4 | 3500 | | |
| | | | 7.3 | 4.3 | 1.9 | 6300 | 9 | EEFSX0E391ER | 3500 | | |
| | 390 | | 7.3 | 4.3 | 1.9 | 7500 | 6 | EEFSX0E391XE | 3500 | | |
| | | | 7.3 | 4.3 | 1.9 | 8500 | 4.5 | EEFSX0E391E4 | 3500 | | |
| | | | 7.3 | 4.3 | 1.9 | 6300 | 9 | EEFSX0E471ER | 3500 | | |
| | 470 | | 7.3 | 4.3 | 1.9 | 7500 | 6 | EEFSX0E471XE | 3500 | | |
| | | | 7.3 | 4.3 | 1.9 | 8500 | 4.5 | EEFSX0E471E4 | 3500 | | |
| | | | 7.3 | 4.3 | 1.9 | 6300 | 9 | EEFSX0G820ER | 3500 | | |
| | 4.0 | | NRFND 82 | 7.3 | 4.3 | 1.9 | 6300 | 9 | EEFSX0G101ER | 3500 | |
| | | | NRFND 100 | 7.3 | 4.3 | 1.9 | 6300 | 9 | EEFSX0G151ER | 3500 | |
| | | | 150 | 7.3 | 4.3 | 1.9 | 6300 | 9 | EEFSX0G151E7 | 3500 | |
| | | 7.3 | | 4.3 | 1.9 | 7000 | 7 | EEFSX0G181ER | 3500 | | |
| | | 180 | 7.3 | 4.3 | 1.9 | 6300 | 9 | EEFSX0G221ER | 3500 | | |
| | | 220 | 7.3 | 4.3 | 1.9 | 6300 | 9 | EEFSX0G271ER | 3500 | | |
| 270 | | 7.3 | 4.3 | 1.9 | 6300 | 9 | EEFSX0G331ER | 3500 | | | |
| | | 7.3 | 4.3 | 1.9 | 7500 | 6 | EEFSX0G331XE | 3500 | | | |
| 6.3 | 120 | 7.3 | 4.3 | 1.9 | 7000 | 7 | EEFSX0J121E7 | 3500 | | | |
| | 150 | 7.3 | 4.3 | 1.9 | 6300 | 9 | EEFSX0J151ER | 3500 | | | |
| | 180 | 7.3 | 4.3 | 1.9 | 6300 | 9 | EEFSX0J181ER | 3500 | | | |
| | 220 | 7.3 | 4.3 | 1.9 | 6300 | 9 | EEFSX0J221ER | 3500 | | | |

*1: Ripple current (100 kHz / +45 °C) *2: ESR (100 kHz / +20 °C)

NRFND Not recommended for new design

◆ Please refer to each page in this catalog for "Reflow conditions" and "Taping specifications".

Temperature coefficient of ripple current

| Temperature | | T ≤ 45 °C | 45 °C < T ≤ 85 °C | 85 °C < T ≤ 105 °C |
|----------------|-------------|-----------|-------------------|--------------------|
| 2.0 V to 6.3 V | Coefficient | 1.0 | 0.7 | 0.25 |

◆ Ripple current should be controlled so that surface temperature of capacitor does not exceed the category temperature.

**Conductive Polymer Aluminum
Electrolytic Capacitors**

Surface Mount Type

GX/GX-L series [Super low ESR products]

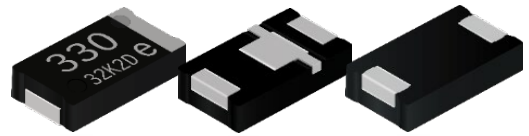

When SP-Cap is designed to be used under constant high load application such as represented in but not limited to the following products such as AI servers, switches, routers, and base stations, we strongly recommend using the long-life series (JX/KX/TX series) and avoid choosing standard series (GX/GX-L series).

Notice: This product is not intended for use in automotive applications.

Features

- Large capacitance (560 μF max.)
- Super Low ESR (3 $\text{m}\Omega$ max.)
- Low ESL (3-terminals : 50 % less than 2-terminals) [Suffix : L]
- High ripple current (10200 mA rms max.)
- RoHS compliance, Halogen free

Specifications

| | | |
|------------------------------------|---|--|
| Series | GX | |
| Category temp. range | -55 °C to +105 °C | |
| Rated voltage range | 2.0 V to 2.5 V | |
| Rated cap. range | 330 μF to 560 μF | |
| Capacitance tolerance | $\pm 20\%$ (120 Hz / +20 °C) | |
| DC leakage current | $I \leq 0.1 \text{ CV}$ (μA) 2 minutes | |
| Dissipation factor (tan δ) | ≤ 0.06 (120 Hz / +20 °C) | |
| Surge voltage (V) | Rated voltage $\times 1.25$ (15 °C to 35 °C) | |
| Endurance | +105 °C 2000 h, rated voltage applied | |
| | Capacitance change | Within $\pm 20\%$ of the initial value |
| | Dissipation factor (tan δ) | ≤ 2 times of the initial limit |
| | DC leakage current | ≤ 3 times of the initial limit |
| Damp heat (Steady state) | +60 °C, 90 % RH, 500 h, No-applied voltage | |
| | Capacitance change of initial measured value | 2.0 V to 2.5 V +70 %, -20 % |
| | Dissipation factor (tan δ) | ≤ 2 times of the initial limit |
| | DC leakage current | Within the initial limit |

Marking

| R. voltage code | Unit : V |
|-----------------|----------|
| d | 2.0 |
| e | 2.5 |

Dimensions (not to scale)

2 terminals

3 terminals

| Unit : mm | | | | | |
|-----------|-------------|--------------|--------------|-------------|-------------|
| Series | L ± 0.2 | W1 ± 0.2 | W2 ± 0.1 | H ± 0.1 | P ± 0.3 |
| GX | 7.3 | 4.3 | 2.4 | 1.9 | 1.3 |

| Unit : mm | | | | | | | | |
|-----------|-------------|--------------|--------------|-------------|--------------|--------------|--------------|--------------|
| Series | L ± 0.2 | W1 ± 0.2 | W2 ± 0.1 | H ± 0.1 | P1 ± 0.3 | P2 ± 0.1 | P3 ± 0.2 | P4 ± 0.2 |
| GX-L | 7.3 | 4.3 | 2.4 | 1.9 | 1.3 | 1.1 | 0.7 | 1.4 |

* Externals of figure are the reference.

Design and specifications are each subject to change without notice. Ask factory for the current technical specifications before purchase and/or use. Should a safety concern arise regarding this product, please be sure to contact us immediately. If delivery specifications suitable for the intended use was not exchanged at the time of product purchase, we will not bear any responsibility.

Explanation of part numbers

◇ Part number system e.g.: EEFGX0D331R

| EEF | | GX | | 0D | | 331 | | R | |
|--------|------------------------|--------|------|-------------------|------|------------------|------|----------|--------------|
| Series | Product classification | Series | Code | Rated Voltage (V) | Code | Capacitance (μF) | Code | ESR (mΩ) | Special code |
| GX | EEF | GX | GX | 2.0 | 0D | 330 | 331 | 3 | L, R |
| | | | | 2.5 | 0E | 470 | 471 | | |
| | | | | | | 560 | 561 | | |

Characteristics list

| Series | Rated voltage (V) | Capacitance (μF) | Case size (mm) | | | Specification | | The number of terminals | | Part number | Min. Packaging Qty (pcs) | |
|--------|-------------------|------------------|----------------|-----|-----|---------------------------------------|-----------------------------|-------------------------|---|-------------|--------------------------|------|
| | | | L | W | H | Ripple current* ¹ (mA rms) | ESR* ² (mΩ max.) | 2 | 3 | | | |
| GX | 2.0 | 330 | 7.3 | 4.3 | 1.9 | 10200 | 3 | ○ | | EEFGX0D331R | 3500 | |
| | | | 7.3 | 4.3 | 1.9 | 10200 | 3 | ○ | | EEFGX0D471R | 3500 | |
| | | 470 | 7.3 | 4.3 | 1.9 | 10200 | 3 | | ○ | EEFGX0D471L | 3500 | |
| | | | 560 | 7.3 | 4.3 | 1.9 | 10200 | 3 | ○ | | EEFGX0D561R | 3500 |
| | | | | 7.3 | 4.3 | 1.9 | 10200 | 3 | | ○ | EEFGX0D561L | 3500 |
| | 2.5 | 330 | 7.3 | 4.3 | 1.9 | 10200 | 3 | ○ | | EEFGX0E331R | 3500 | |
| | | | 470 | 7.3 | 4.3 | 1.9 | 10200 | 3 | ○ | | EEFGX0E471R | 3500 |
| | | 7.3 | | 4.3 | 1.9 | 10200 | 3 | | ○ | EEFGX0E471L | 3500 | |
| | | | | | | | | | | | | |

*1: Ripple current (100 kHz / +45 °C)

*2: ESR (100 kHz / +20 °C)

◆ Please refer to each page in this catalog for "Reflow conditions" and "Taping specifications".

Temperature coefficient of ripple current

| Temperature | | T ≤ 45 °C | 45 °C < T ≤ 85 °C | 85 °C < T ≤ 105 °C |
|----------------|-------------|-----------|-------------------|--------------------|
| 2.0 V to 2.5 V | Coefficient | 1.0 | 0.7 | 0.25 |

◆ Ripple current should be controlled so that surface temperature of capacitor does not exceed the category temperature.

Conductive Polymer Aluminum Electrolytic Capacitors

Surface Mount Type

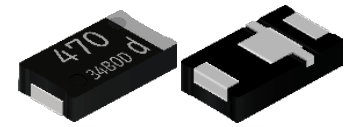

LX series [Low ESR / Low ESL products]

When SP-Cap is designed to be used under constant high load application such as represented in but not limited to the following products such as AI servers, switches, routers, and base stations, we strongly recommend using the long-life series (JX/KX/TX series) and avoid choosing standard series (LX series).

Notice: This product is not intended for use in automotive applications.

Features

- Large capacitance (560 μF max.)
- Low ESR (4.5 $\text{m}\Omega$, 6 $\text{m}\Omega$ max.)
- Low ESL (3-terminals : 50 % less than 2-terminals)
- High ripple current (8500 mA rms max.)
- RoHS compliance, Halogen free

Specifications

| | | |
|--------------------------------------|---|--|
| Series | LX | |
| Category temp. range | -55 °C to +105 °C | |
| Rated voltage range | 2.0 V to 2.5 V | |
| Rated cap. range | 330 μF to 560 μF | |
| Capacitance tolerance | $\pm 20\%$ (120 Hz / +20 °C) | |
| DC leakage current | $I \leq 0.1 \text{ CV}$ (μA) 2 minutes | |
| Dissipation factor ($\tan \delta$) | ≤ 0.06 (120 Hz / +20 °C) | |
| Surge voltage (V) | Rated voltage $\times 1.25$ (15 °C to 35 °C) | |
| Endurance | +105 °C 2000 h, rated voltage applied | |
| | Capacitance change | Within $\pm 20\%$ of the initial value |
| | Dissipation factor ($\tan \delta$) | ≤ 2 times of the initial limit |
| | DC leakage current | ≤ 3 times of the initial limit |
| Damp heat (Steady state) | +60 °C, 90 % RH, 500 h, No-applied voltage | |
| | Capacitance change of initial measured value | 2.0 V to 2.5 V +70 %, -20 % |
| | Dissipation factor ($\tan \delta$) | ≤ 2 times of the initial limit |
| | DC leakage current | Within the initial limit |

Marking Dimensions (not to scale)

Capacitance (μF) Polarity bar (Positive)

Lot No. R. voltage code

| R. voltage code | Unit : V |
|-----------------|----------|
| d | 2.0 |
| e | 2.5 |

3 terminals

| Series | L ± 0.2 | W1 ± 0.2 | W2 ± 0.1 | H ± 0.1 | P1 ± 0.3 | P2 ± 0.1 | P3 ± 0.2 | P4 ± 0.2 |
|--------|-------------|--------------|--------------|-------------|--------------|--------------|--------------|--------------|
| LX | 7.3 | 4.3 | 2.4 | 1.9 | 1.3 | 1.1 | 0.7 | 1.4 |

Unit : mm

* Externals of figure are the reference.

Explanation of part numbers

◇ Part number system e.g.: EEFLX0D331R

| EEF | | LX | | 0D | | 331 | | R | |
|--------|------------------------|--------|------|-------------------|------|------------------|------|----------|--------------|
| Series | Product classification | Series | Code | Rated Voltage (V) | Code | Capacitance (μF) | Code | ESR (mΩ) | Special code |
| LX | EEF | LX | LX | 2.0 | 0D | 330 | 331 | 4.5 | R4 |
| | | | | 2.5 | 0E | 470 | 471 | 6 | R |
| | | | | | | 560 | 561 | | |

Characteristics list

| Series | Rated voltage (V) | Capacitance (μF) | Case size (mm) | | | Specification | | Part number | Min. Packaging Q'ty (pcs) |
|--------|-------------------|------------------|----------------|-----|-----|---------------------------------------|-----------------------------|--------------|---------------------------|
| | | | L | W | H | Ripple current* ¹ (mA rms) | ESR* ² (mΩ max.) | | |
| LX | 2.0 | 330 | 7.3 | 4.3 | 1.9 | 7500 | 6 | EEFLX0D331R | 3500 |
| | | | 7.3 | 4.3 | 1.9 | 8500 | 4.5 | EEFLX0D331R4 | 3500 |
| | | 470 | 7.3 | 4.3 | 1.9 | 7500 | 6 | EEFLX0D471R | 3500 |
| | | | 7.3 | 4.3 | 1.9 | 8500 | 4.5 | EEFLX0D471R4 | 3500 |
| | | 560 | 7.3 | 4.3 | 1.9 | 7500 | 6 | EEFLX0D561R | 3500 |
| | | | 7.3 | 4.3 | 1.9 | 8500 | 4.5 | EEFLX0D561R4 | 3500 |
| | 2.5 | 330 | 7.3 | 4.3 | 1.9 | 7500 | 6 | EEFLX0E331R | 3500 |
| | | | 7.3 | 4.3 | 1.9 | 8500 | 4.5 | EEFLX0E331R4 | 3500 |
| | | 470 | 7.3 | 4.3 | 1.9 | 7500 | 6 | EEFLX0E471R | 3500 |
| | | | 7.3 | 4.3 | 1.9 | 8500 | 4.5 | EEFLX0E471R4 | 3500 |

*1: Ripple current (100 kHz / +45 °C)

*2: ESR (100 kHz / +20 °C)

◆ Please refer to each page in this catalog for "Reflow conditions" and "Taping specifications".

Temperature coefficient of ripple current

| Temperature | | T ≤ 45 °C | 45 °C < T ≤ 85 °C | 85 °C < T ≤ 105 °C |
|----------------|-------------|-----------|-------------------|--------------------|
| 2.0 V to 2.5 V | Coefficient | 1.0 | 0.7 | 0.25 |

◆ Ripple current should be controlled so that surface temperature of capacitor does not exceed the category temperature.

Conductive Polymer Aluminum Electrolytic Capacitors

Surface Mount Type

SR/LR/SS/LS/ST/LT series



When SP-Cap is designed to be used under constant high load application such as represented in but not limited to the following products such as AI servers, switches, routers, and base stations, we strongly recommend using the long-life series (JX/KX/TX series) and avoid choosing standard series (SR/LR/SS/LS/ST/LT series).

Notice: This product is not intended for use in automotive applications.

Features

- Low profile (Height 1.0 mm max.)
- Low ESR (4.5 mΩ to 9 mΩ max.)
- Low ESL (3-terminals : 50% less than 2-terminals) [LR/LS/LT series]
- High ripple current (8500 mA rms max.)
- RoHS compliance, Halogen free

Specifications

| Series | SR | LR | SS | LS | ST | LT |
|----------------------------|---|--------------------------|-----------------------------------|----|------------------|----|
| Category temp. range | -55 °C to +105 °C | | | | | |
| Rated voltage range | 2.0 V to 6.3 V | | 2.0 V to 2.5 V | | | |
| Rated cap. range | 68 μF to 220 μF | | 180 μF to 220 μF | | 270 μF to 330 μF | |
| Capacitance tolerance | ±20 % (120 Hz / +20 °C) | | | | | |
| DC leakage current | I ≤ 0.1 CV (μA) 2 minutes | | | | | |
| Dissipation factor (tan δ) | ≤ 0.06 (120 Hz / +20 °C) | | | | | |
| Surge voltage (V) | Rated voltage × 1.25 (15 °C to 35 °C) | | | | | |
| Endurance | +105 °C 2000 h, rated voltage applied | | | | | |
| | Capacitance change | | Within ±20 % of the initial value | | | |
| | Dissipation factor (tan δ) | | ≤ 2 times of the initial limit | | | |
| | DC leakage current | | ≤ 3 times of the initial limit | | | |
| Damp heat (Steady state) | +60 °C, 90 % RH, 500 h, No-applied voltage | | | | | |
| | Capacitance change of initial measurd value | | 2.0 V to 2.5 V | | 6.3 V | |
| | | | +70 %, -20 % | | +60 %, -20 % | |
| | Dissipation factor (tan δ) | | ≤ 2 times of the initial limit | | | |
| DC leakage current | | Within the initial limit | | | | |

Marking

| R. voltage code | Unit : V |
|-----------------|----------|
| d | 2.0 |
| e | 2.5 |
| g | 4.0 |
| j | 6.3 |

Dimensions (not to scale)

2 terminals

3 terminals

SR/SS/ST series

| Series | L±0.2 | W1±0.2 | W2±0.1 | H±0.1 | P±0.3 |
|--------|-------|--------|--------|-------------------|-------|
| SR | 7.3 | 4.3 | 2.4 | 1.0 ⁻¹ | 1.3 |
| SS | 7.3 | 4.3 | 2.4 | 1.1 | 1.3 |
| ST | 7.3 | 4.3 | 2.4 | 1.4 | 1.3 |

*1: max.

LR/LS/LT series

| Series | L±0.2 | W1±0.2 | W2±0.1 | H±0.1 | P1±0.3 | P2±0.1 | P3±0.2 | P4±0.2 |
|--------|-------|--------|--------|-------------------|--------|--------|--------|--------|
| LR | 7.3 | 4.3 | 2.4 | 1.0 ⁻¹ | 1.3 | 1.1 | 0.7 | 1.4 |
| LS | 7.3 | 4.3 | 2.4 | 1.1 | 1.3 | 1.1 | 0.7 | 1.4 |
| LT | 7.3 | 4.3 | 2.4 | 1.4 | 1.3 | 1.1 | 0.7 | 1.4 |

*1: max.

* Externals of figure are the reference.

Design and specifications are each subject to change without notice. Ask factory for the current technical specifications before purchase and/or use.

Should a safety concern arise regarding this product, please be sure to contact us immediately.

If delivery specifications suitable for the intended use was not exchanged at the time of product purchase, we will not bear any responsibility.

Explanation of part numbers

◇ Part number system e.g.: EEFSR0D221R4

| EEF | | SR | | 0D | | 221 | | R4 | | | |
|--------|------------------------|--------|------|-------------------|------|------------------|------|------------------|------|----------------|--------------|
| Series | Product classification | Series | Code | Rated Voltage (V) | Code | Capacitance (μF) | Code | Capacitance (μF) | Code | ESR (mΩ) | Special code |
| SR | EEF | SR | SR | 2.0 | 0D | 68 | 680 | 220 | 221 | 4.5 | R4 |
| SS | | SS | SS | 2.5 | 0E | 120 | 121 | 270 | 271 | 6 (2.0, 2.5 V) | R |
| ST | | ST | ST | 4.0 | 0G | 180 | 181 | 330 | 331 | 9 (4.0, 6.3 V) | |
| LR | | LR | LR | 6.3 | 0J | | | | | | |
| LS | | LS | LS | | | | | | | | |
| LT | | LT | LT | | | | | | | | |

Characteristics list

| Series | Rated voltage (V) | Capacitance (μF) | Case size (mm) | | | Specification | | The number of terminals | | Part number | Min. Packaging Qty (pcs) |
|--------|-------------------|------------------|----------------|-----|----------|---------------------------------------|-----------------------------|-------------------------|---|--------------|--------------------------|
| | | | L | W | H | Ripple current ^{*1} (mA rms) | ESR ^{*2} (mΩ max.) | 2 | 3 | | |
| SR | 2.0 | 220 | 7.3 | 4.3 | 1.0 max. | 7500 | 6 | ○ | | EEFSR0D221R | 3500 |
| | | | 7.3 | 4.3 | 1.0 max. | 8500 | 4.5 | ○ | | EEFSR0D221R4 | 3500 |
| | 2.5 | 180 | 7.3 | 4.3 | 1.0 max. | 7500 | 6 | ○ | | EEFSR0E181R | 3500 |
| | | | 7.3 | 4.3 | 1.0 max. | 8500 | 4.5 | ○ | | EEFSR0E181R4 | 3500 |
| | 4.0 | 120 | 7.3 | 4.3 | 1.0 max. | 6300 | 9 | ○ | | EEFSR0G121R | 3500 |
| | 6.3 | 68 | 7.3 | 4.3 | 1.0 max. | 6300 | 9 | ○ | | EEFSR0J680R | 3500 |
| LR | 2.0 | 220 | 7.3 | 4.3 | 1.0 max. | 7500 | 6 | | ○ | EEFLR0D221R | 3500 |
| | | | 7.3 | 4.3 | 1.0 max. | 8500 | 4.5 | | ○ | EEFLR0D221R4 | 3500 |
| | 2.5 | 180 | 7.3 | 4.3 | 1.0 max. | 7500 | 6 | | ○ | EEFLR0E181R | 3500 |
| | | | 7.3 | 4.3 | 1.0 max. | 8500 | 4.5 | | ○ | EEFLR0E181R4 | 3500 |
| | 4.0 | 120 | 7.3 | 4.3 | 1.0 max. | 6300 | 9 | | ○ | EEFLR0G121R | 3500 |
| | 6.3 | 68 | 7.3 | 4.3 | 1.0 max. | 6300 | 9 | | ○ | EEFLR0J680R | 3500 |
| SS | 2.0 | 220 | 7.3 | 4.3 | 1.1 | 7500 | 6 | ○ | | EEFSS0D221R | 3500 |
| | 2.5 | 180 | 7.3 | 4.3 | 1.1 | 7500 | 6 | ○ | | EEFSS0E181R | 3500 |
| LS | 2.0 | 220 | 7.3 | 4.3 | 1.1 | 7500 | 6 | | ○ | EEFLS0D221R | 3500 |
| | 2.5 | 180 | 7.3 | 4.3 | 1.1 | 7500 | 6 | | ○ | EEFLS0E181R | 3500 |
| ST | 2.0 | 330 | 7.3 | 4.3 | 1.4 | 7500 | 6 | ○ | | EEFST0D331R | 3500 |
| | 2.5 | 270 | 7.3 | 4.3 | 1.4 | 7500 | 6 | ○ | | EEFST0E271R | 3500 |
| LT | 2.0 | 330 | 7.3 | 4.3 | 1.4 | 7500 | 6 | | ○ | EEFLT0D331R | 3500 |
| | 2.5 | 270 | 7.3 | 4.3 | 1.4 | 7500 | 6 | | ○ | EEFLT0E271R | 3500 |

*1: Ripple current (100 kHz / +45 °C)

*2: ESR (100 kHz / +20 °C)

◆ Please refer to each page in this catalog for "Reflow conditions" and "Taping specifications".

Temperature coefficient of ripple current

| Temperature | | T ≤ 45 °C | 45 °C < T ≤ 85 °C | 85 °C < T ≤ 105 °C |
|----------------|-------------|-----------|-------------------|--------------------|
| 2.0 V to 6.3 V | Coefficient | 1.0 | 0.7 | 0.25 |

◆ Ripple current should be controlled so that surface temperature of capacitor does not exceed the category temperature.

**Conductive Polymer Aluminum
Electrolytic Capacitors**
Surface Mount Type

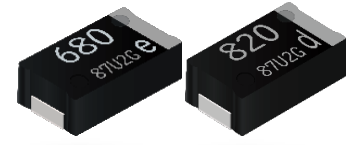

GY series [Super low ESR]

When SP-Cap is designed to be used under constant high load application such as represented in but not limited to the following products such as AI servers, switches, routers, and base stations, we strongly recommend using the long-life series (JX/KX/TX series) and avoid choosing standard series (GY series).

Notice: This product is not intended for use in automotive applications.

Features

- Super low ESR (3 mΩ max.)
- Large capacitance (820 μF max.)
- High ripple current (10200 mA rms max.)
- RoHS compliance, Halogen free

Specifications

| Series | GY | |
|----------------------------|--|-----------------------------------|
| Category temp. range | -55 °C to +105 °C | |
| Rated voltage range | 2.0 V to 2.5 V | |
| Rated cap. range | 680 μF to 820 μF | |
| Capacitance tolerance | ±20 % (120 Hz / +20 °C) | |
| DC leakage current | I ≤ 0.1 CV (μA) 2 minutes | |
| Dissipation factor (tan δ) | ≤ 0.06 (120 Hz / + 20 °C) | |
| Surge voltage (V) | Rated voltage × 1.25 (15 °C to 35 °C) | |
| Endurance | +105 °C 2000 h, rated voltage applied | |
| | Capacitance change | Within ±20 % of the initial value |
| | Dissipation factor (tan δ) | ≤ 2 times of the initial limit |
| | DC leakage current | ≤ 3 times of the initial limit |
| Damp heat (Steady state) | +60 °C, 90 % RH, 500 h, No-applied voltage | |
| | Capacitance change of initial measured value | 2.0 V to 2.5 V +70 %, -20 % |
| | Dissipation factor (tan δ) | ≤ 2 times of the initial limit |
| | DC leakage current | Within the initial limit |

Marking

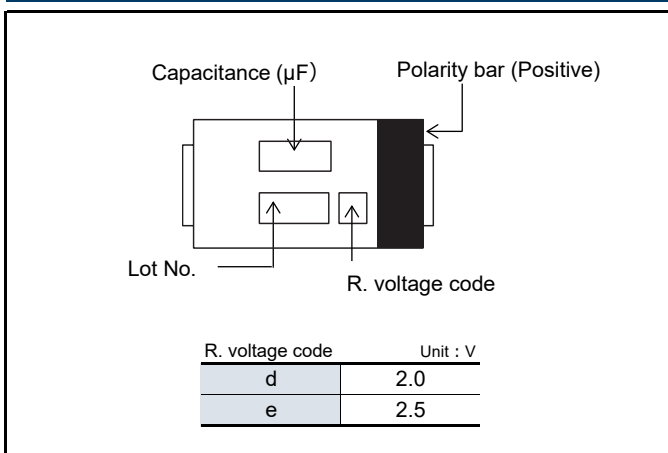

Dimensions (not to scale)

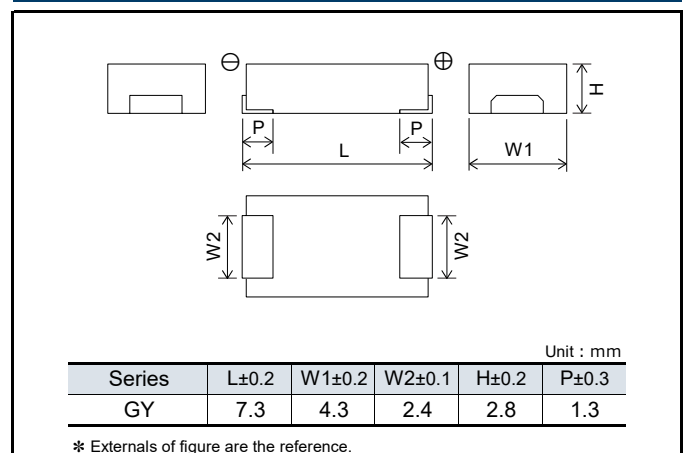

Explanation of part numbers

◇ **Part number system** e.g.: EEFGY0D821R

| | | | | | | | | | |
|------------|------------------------|-----------|------|-------------------|------|------------------|------|----------|--------------|
| EEF | | GY | | 0D | | 821 | | R | |
| Series | Product classification | Series | Code | Rated Voltage (V) | Code | Capacitance (μF) | Code | ESR (mΩ) | Special code |
| GY | EEF | GY | GY | 2.0 | 0D | 680 | 681 | 3 | R |
| | | | | 2.5 | 0E | 820 | 821 | | |

Characteristics list

| Series | Rated voltage (V) | Capacitance (μF) | Case size (mm) | | | Specification | | Part number | Min. Packaging Q'ty (pcs) |
|--------|-------------------|------------------|----------------|-----|-----|---------------------------------------|-----------------------------|-------------|---------------------------|
| | | | L | W | H | Ripple current ^{*1} (mA rms) | ESR ^{*2} (mΩ max.) | | |
| GY | 2.0 | 820 | 7.3 | 4.3 | 2.8 | 10200 | 3 | EEFGY0D821R | 2000 |
| | 2.5 | 680 | 7.3 | 4.3 | 2.8 | 10200 | 3 | EEFGY0E681R | 2000 |

*1: Ripple current (100 kHz / +45 °C)

*2: ESR (100 kHz / +20 °C)

◆ Please refer to each page in this catalog for "Reflow conditions" and "Taping specifications".

Temperature coefficient of ripple current

| Temperature | | T ≤ 45 °C | 45 °C < T ≤ 85 °C | 85 °C < T ≤ 105 °C |
|----------------|-------------|-----------|-------------------|--------------------|
| 2.0 V to 2.5 V | Coefficient | 1.0 | 0.7 | 0.25 |

◆ Ripple current should be controlled so that surface temperature of capacitor does not exceed the category temperature.

**Conductive Polymer Aluminum
Electrolytic Capacitors**
Surface Mount Type

CY/SY series [Guaranteed at 85 °C]

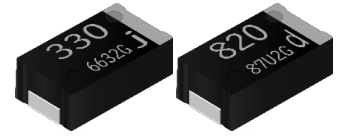

When SP-Cap is designed to be used under constant high load application such as represented in but not limited to the following products such as AI servers, switches, routers, and base stations, we strongly recommend using the long-life series (JX/KX/TX series) and avoid choosing standard series (CY/SY series).

Notice: This product is not intended for use in automotive applications.

Features

- Endurance 85 °C 2000 h
- Product height (3.0 mm max.)
- High ripple current (5100 mA rms to 6300 mA rms max.)
- RoHS compliance, Halogen free

Specifications

| | | |
|----------------------------|---|-----------------------------------|
| Series | CY / SY | |
| Category temp. range | -55 °C to +85 °C | |
| Rated voltage range | 4.0 V, 6.3V | |
| Rated cap. range | 330 μF to 470 μF | |
| Capacitance tolerance | ±20 % (120 Hz / +20 °C) | |
| DC leakage current | I ≤ 0.1 CV (μA) 2 minutes | |
| Dissipation factor (tan δ) | ≤ 0.06 (120 Hz / + 20 °C) | |
| Surge voltage (V) | Rated voltage × 1.25 (15 °C to 35 °C) | |
| Endurance | +85 °C 2000 h, rated voltage applied | |
| | Capacitance change | Within ±20 % of the initial value |
| | Dissipation factor (tan δ) | ≤ 2 times of the initial limit |
| | DC leakage current | ≤ 3 times of the initial limit |
| Damp heat (Steady state) | +60 °C, 90 % RH, 500 h, No-applied voltage | |
| | Capacitance change of initial measurd value | 4.0 V +60 %, -20 % |
| | | 6.3 V +50 %, -20 % |
| | Dissipation factor (tan δ) | ≤ 2 times of the initial limit |
| DC leakage current | Within the initial limit | |

Marking

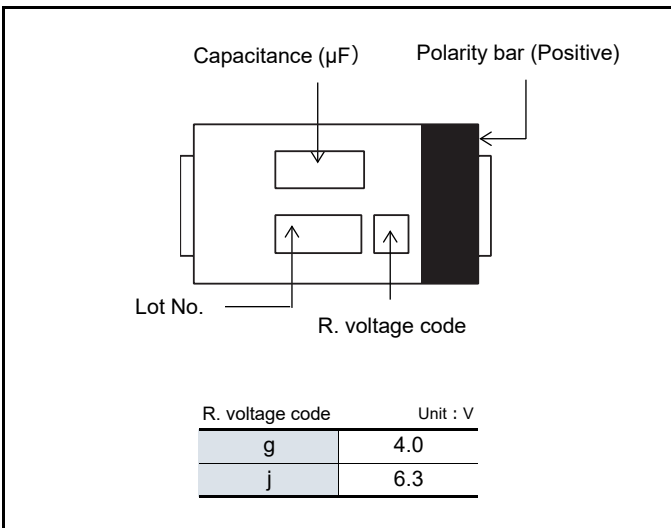

Dimensions (not to scale)

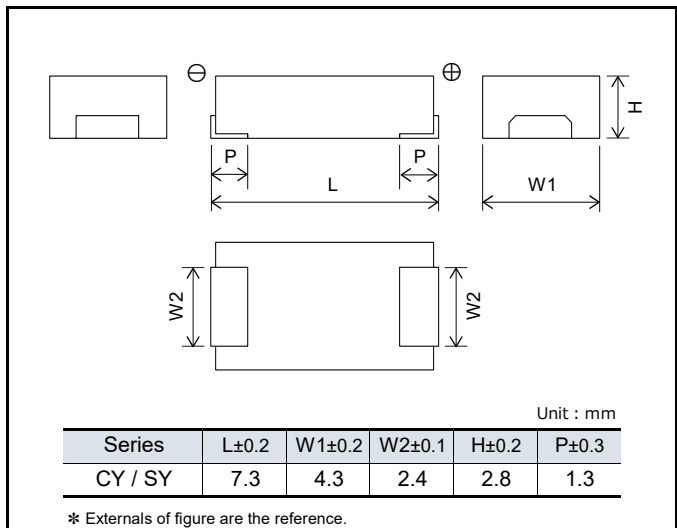

Explanation of part numbers

◇ Part number system e.g.: ECGCY0G471R

| ECG | | CY | | 0G | | 471 | | R | |
|--------|------------------------|--------|------|-------------------|------|------------------|------|----------|--------------|
| Series | Product classification | Series | Code | Rated Voltage (V) | Code | Capacitance (μF) | Code | ESR (mΩ) | Special code |
| CY | ECG | CY | CY | 4.0 | 0G | 330 | 331 | 9, 15 | R |
| SY | | SY | SY | 6.3 | 0J | 470 | 471 | | |

Characteristics list

| Series | Rated voltage (V) | Capacitance (μF) | Case size (mm) | | | Specification | | Part number | Min. Packaging Q'ty (pcs) |
|--------|-------------------|------------------|----------------|-----|-----|---------------------------------------|-----------------------------|-------------|---------------------------|
| | | | L | W | H | Ripple current* ¹ (mA rms) | ESR* ² (mΩ max.) | | |
| CY | 4.0 | 470 | 7.3 | 4.3 | 2.8 | 5100 | 15 | ECGCY0G471R | 2000 |
| | 6.3 | 330 | 7.3 | 4.3 | 2.8 | 5100 | 15 | ECGCY0J331R | 2000 |
| SY | 4.0 | 470 | 7.3 | 4.3 | 2.8 | 6300 | 9 | ECGSY0G471R | 2000 |
| | 6.3 | 330 | 7.3 | 4.3 | 2.8 | 6300 | 9 | ECGSY0J331R | 2000 |

*1: Ripple current (100 kHz / +45 °C)

*2: ESR (100 kHz / +20 °C)

◆ Please refer to each page in this catalog for "Reflow conditions" and "Taping specifications".

Temperature coefficient of ripple current

| Temperature | | T ≤ 45 °C | 45 °C < T ≤ 65 °C | 65 °C < T ≤ 85 °C |
|----------------|-------------|-----------|-------------------|-------------------|
| 4.0 V to 6.3 V | Coefficient | 1.0 | 0.7 | 0.25 |

◆ Ripple current should be controlled so that surface temperature of capacitor does not exceed the category temperature.

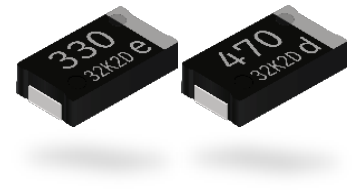

Conductive Polymer Aluminum Electrolytic Capacitors

Surface Mount Type

HX series [Guaranteed at 125 °C]

When SP-Cap is designed to be used under constant high load application such as represented in but not limited to the following products such as AI servers, switches, routers, and base stations, we strongly recommend using the long-life series (JX/KX/TX series) and avoid choosing standard series (HX series).

Notice: This product is not intended for use in automotive applications.

Features

- Endurance 125 °C 1000 h
- High voltage & Large capacitance (2.0 V / 470 μF to 25 V / 33 μF)
- Low ESR (4.5 mΩ max.)
- RoHS compliance, Halogen free

Specifications

| Series | HX | |
|----------------------------|--|--|
| Category temp. range | -55 °C to +125 °C | |
| Rated voltage range | 2.0 V to 2.5 V, 10 V to 25 V | |
| Category voltage range | 1.6 V to 2.0 V, 8.0 V to 20 V | |
| Rated cap. range | 15 μF to 470 μF | |
| Capacitance tolerance | ±20 % (120 Hz / +20 °C) | |
| DC leakage current | I ≤ 0.1 CV(μA) [2.0 V to 2.5 V, 2 min], I ≤ 0.3 CV(μA) [10 V to 25 V, 2 min] | |
| Dissipation factor (tan δ) | ≤ 0.1 (120 Hz / +20 °C) | |
| Surge voltage (V) | Rated voltage × 1.25 [2.0 V to 16 V], × 1.15 [20 V to 25 V] (15 °C to 35 °C) | |
| Endurance | +125 °C 1000 h, category voltage applied | |
| | Capacitance change | Within ±20 % of the initial value |
| | Dissipation factor (tan δ) | ≤ 2 times of the initial limit |
| | DC leakage current | Within the initial limit |
| Damp heat (Steady state) | After storing for 500 hours at +60 °C, 90 % RH | |
| | Capacitance change of initial measured value | 2.0 V to 2.5 V : +70 %, -20 % 10 V to 25 V : +60 %, -20 % |
| | Dissipation factor (tan δ) | ≤ 2 times of the initial limit |
| | DC leakage current | Within the initial limit : 2.0 V to 2.5 V ≤ 3 times of the initial limit : 10 V to 25 V |

Marking

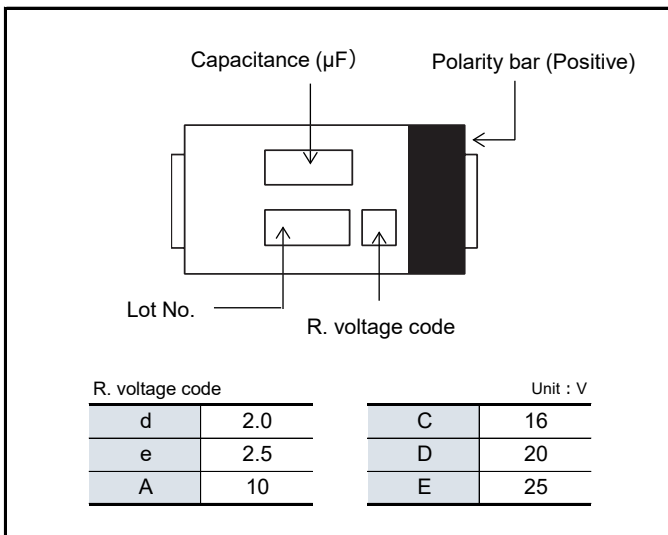

Dimensions (not to scale)

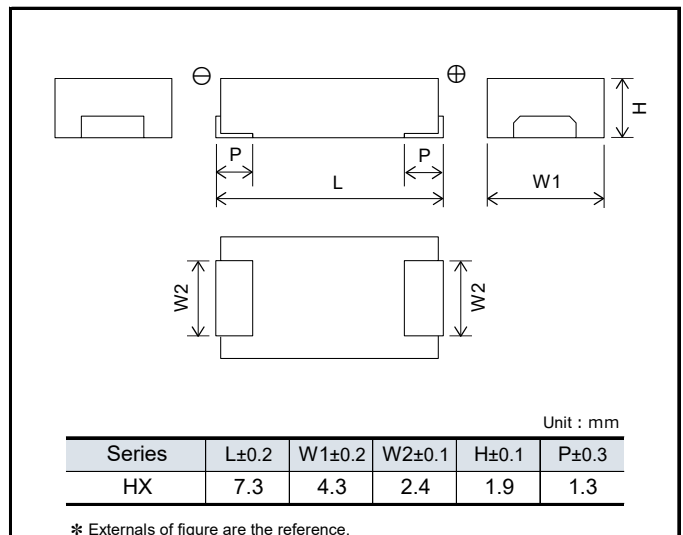

Explanation of part numbers

◇ **Part number system** e.g.: EEFHX0D471R9

| EEF | | HX | | 0D | | 471 | | R9 | | | |
|--------|------------------------|--------|------|-------------------|------|------------------|------|------------------|------|-----------------|--------------|
| Series | Product classification | Series | Code | Rated Voltage (V) | Code | Capacitance (μF) | Code | Capacitance (μF) | Code | ESR (mΩ) | Special Code |
| HX | EEF | HX | HX | 2.0 | 0D | 15 | 150 | 68 | 680 | 15 (2.0, 2.5 V) | R |
| | | | | 2.5 | 0E | 22 | 220 | 100 | 101 | 40 (10 to 25 V) | |
| | | | | 10 | 1A | 33 | 330 | 330 | 331 | 4.5 | R4 |
| | | | | 16 | 1C | 47 | 470 | 470 | 471 | 6 | R6 |
| | | | | 20 | 1D | 56 | 560 | | | 9 | R9 |
| | | | | 25 | 1E | | | | | | |

Characteristics list

■ **2.0 V to 2.5 V**

| Series | Rated voltage [105 °C] (V) | Category voltage [125 °C] (V) | Capacitance (μF) | Case size (mm) | | | Specification | | Part number | Min. Packaging Qty (pcs) |
|--------|----------------------------|-------------------------------|------------------|----------------|-----|-----|---------------------------|-----------------|--------------|--------------------------|
| | | | | L | W | H | Ripple current*1 (mA rms) | ESR*2 (mΩ max.) | | |
| HX | 2.0 | 1.6 | 470 | 7.3 | 4.3 | 1.9 | 5100 | 15 | EEFHX0D471R | 3500 |
| | | | | 7.3 | 4.3 | 1.9 | 6300 | 9 | EEFHX0D471R9 | 3500 |
| | | | | 7.3 | 4.3 | 1.9 | 7500 | 6 | EEFHX0D471R6 | 3500 |
| | | | | 7.3 | 4.3 | 1.9 | 8500 | 4.5 | EEFHX0D471R4 | 3500 |
| | 2.5 | 2.0 | 330 | 7.3 | 4.3 | 1.9 | 5100 | 15 | EEFHX0E331R | 3500 |
| | | | | 7.3 | 4.3 | 1.9 | 6300 | 9 | EEFHX0E331R9 | 3500 |
| | | | | 7.3 | 4.3 | 1.9 | 7500 | 6 | EEFHX0E331R6 | 3500 |
| | | | | 7.3 | 4.3 | 1.9 | 8500 | 4.5 | EEFHX0E331R4 | 3500 |
| | | | 470 | 7.3 | 4.3 | 1.9 | 5100 | 15 | EEFHX0E471R | 3500 |
| | | | | 7.3 | 4.3 | 1.9 | 6300 | 9 | EEFHX0E471R9 | 3500 |
| | | | | 7.3 | 4.3 | 1.9 | 7500 | 6 | EEFHX0E471R6 | 3500 |
| | | | | 7.3 | 4.3 | 1.9 | 8500 | 4.5 | EEFHX0E471R4 | 3500 |

■ **10 V to 25 V**

Not Recommended for New Design

For replacement

| Series | Rated voltage [105 °C] (V) | Category voltage [125 °C] (V) | Capacitance (μF) | Case size (mm) | | | Specification | | Part number | Min. Packaging Qty (pcs) |
|--------|----------------------------|-------------------------------|------------------|----------------|-----|-----|---------------------------|-----------------|-------------|--------------------------|
| | | | | L | W | H | Ripple current*1 (mA rms) | ESR*2 (mΩ max.) | | |
| HX | 10 | 8.0 | 47 | 7.3 | 4.3 | 1.9 | 3200 | 40 | EEFHX1A470R | 3500 |
| | | | 68 | 7.3 | 4.3 | 1.9 | 3200 | 40 | EEFHX1A680R | 3500 |
| | | | 100 | 7.3 | 4.3 | 1.9 | 3200 | 40 | EEFHX1A101R | 3500 |
| | 16 | 12.8 | 15 | 7.3 | 4.3 | 1.9 | 3200 | 40 | EEFHX1C150R | 3500 |
| | | | 22 | 7.3 | 4.3 | 1.9 | 3200 | 40 | EEFHX1C220R | 3500 |
| | | | 33 | 7.3 | 4.3 | 1.9 | 3200 | 40 | EEFHX1C330R | 3500 |
| | | | 47 | 7.3 | 4.3 | 1.9 | 3200 | 40 | EEFHX1C470R | 3500 |
| | 20 | 16 | 68 | 7.3 | 4.3 | 1.9 | 3200 | 40 | EEFHX1C680R | 3500 |
| | | | 22 | 7.3 | 4.3 | 1.9 | 3200 | 40 | EEFHX1D220R | 3500 |
| | | | 33 | 7.3 | 4.3 | 1.9 | 3200 | 40 | EEFHX1D330R | 3500 |
| | | | 47 | 7.3 | 4.3 | 1.9 | 3200 | 40 | EEFHX1D470R | 3500 |
| | 25 | 20 | 56 | 7.3 | 4.3 | 1.9 | 3200 | 40 | EEFHX1D560R | 3500 |
| | | | 15 | 7.3 | 4.3 | 1.9 | 3200 | 40 | EEFHX1E150R | 3500 |
| | | | 22 | 7.3 | 4.3 | 1.9 | 3200 | 40 | EEFHX1E220R | 3500 |
| | | | 33 | 7.3 | 4.3 | 1.9 | 3200 | 40 | EEFHX1E330R | 3500 |
| | | | | | | | | | | |

*1: Ripple current (100 kHz / +45 °C) *2: ESR (100 kHz / +20 °C)

◆ Please refer to each page in this catalog for "Reflow conditions" and "Taping specifications".

Temperature coefficient of ripple current

| Temperature | | T ≤ 45 °C | 45 °C < T ≤ 85 °C | 85 °C < T ≤ 105 °C | 105 °C < T ≤ 125 °C |
|----------------|-------------|-----------|-------------------|--------------------|---------------------|
| 2.0 V to 2.5 V | Coefficient | 1.0 | 0.7 | 0.25 | 0.25 |
| 10 V to 25 V | | 1.0 | 0.8 | 0.5 | 0.25 |

◆ Ripple current should be controlled so that surface temperature of capacitor does not exceed the category temperature.

Design and specifications are each subject to change without notice. Ask factory for the current technical specifications before purchase and/or use. Should a safety concern arise regarding this product, please be sure to contact us immediately. If delivery specifications suitable for the intended use was not exchanged at the time of product purchase, we will not bear any responsibility.

Replacement list for “Not recommended for new design”

* If you are using any of the following models on the deleted list, please substitute them with the suggested alternative model as soon as possible.

| Non-recommended part number | | | | | | Replacement part number | | | | | | | |
|-----------------------------|---------------------------------|-------------------|-------------------|-------------|-------------|-------------------------|-----------|---------------------------------|-------------------|-------------------|-----------------------------|------------------------------|-----------------------------|
| Series | Cate-gory temp. range max. (°C) | Rated voltage (V) | Capaci-tance (µF) | ESR (mΩ) | Part number | Series | Size code | Cate-gory temp. range max. (°C) | Rated voltage (V) | Capaci-tance (µF) | ESR (mΩ) | Part number | |
| CS | 105 | 10 | 47 | 40 | EEFCS1A470R | POSCAP TQC | D15 | 105 | 16 | 47 | 55 | 16TQC47MYFT | |
| | | | | | | POSCAP TPE | B2 | 85 | 10 | 47 | 35 | 10TPE47MAZB | |
| | | | | | | OS-CON SVP | C6 | 105 | 10 | 47 | 50 | 10SVP47M | |
| | | | | | | Hybrid ZA | D | 105 | 25 | 47 | 50 | EEHZA1E470P | |
| | 105 | 16 | 15 | 40 | EEFCS1C150R | POSCAP TQC | D15 | 105 | 16 | 47 | 55 | 16TQC47MYFT | |
| | | | | | | OS-CON SVP | B6 | 105 | 16 | 22 | 90 | 16SVP22M | |
| | | | | | | Hybrid ZA | C | 105 | 25 | 22 | 80 | EEHZA1E220R | |
| | 105 | 16 | 22 | 40 | EEFCS1C220R | POSCAP TQC | D15 | 105 | 16 | 47 | 55 | 16TQC47MYFT | |
| | | | | | | OS-CON SVP | B6 | 105 | 16 | 22 | 90 | 16SVP22M | |
| | | | | | | Hybrid ZA | C | 105 | 25 | 22 | 80 | EEHZA1E220R | |
| | 105 | 16 | 33 | 40 | EEFCS1C330R | POSCAP TQC | D15 | 105 | 16 | 47 | 55 | 16TQC47MYFT | |
| | | | | | | OS-CON SVPC | B6 | 105 | 16 | 39 | 27 | 16SVPC39MV | |
| | | | | | | Hybrid ZA | C | 105 | 25 | 33 | 80 | EEHZA1E330R | |
| | 105 | 20 | 10 | 40 | EEFCS1D100R | POSCAP TQC | D15 | 105 | 20 | 47 | 55 | 20TQC47MYFT | |
| | | | | | | OS-CON SVPA | B6 | 105 | 20 | 10 | 40 | 20SVPA10M | |
| | | | | | | Hybrid ZA | C | 105 | 35 | 10 | 100 | EEHZA1V100R | |
| | 105 | 20 | 15 | 40 | EEFCS1D150R | POSCAP TQC | D15 | 105 | 20 | 47 | 55 | 20TQC47MYFT | |
| | | | | | | OS-CON SVPA | C6 | 105 | 20 | 22 | 35 | 20SVPA22M | |
| | | | | | | Hybrid ZA | C | 105 | 25 | 22 | 80 | EEHZA1E220R | |
| | 105 | 20 | 22 | 40 | EEFCS1D220R | POSCAP TQC | D15 | 105 | 20 | 47 | 55 | 20TQC47MYFT | |
| | | | | | | OS-CON SVPA | C6 | 105 | 20 | 22 | 35 | 20SVPA22M | |
| | | | | | | Hybrid ZA | C | 105 | 25 | 22 | 80 | EEHZA1E220R | |
| | 105 | 25 | 10 | 40 | EEFCS1E100R | POSCAP TQC | D2 | 105 | 25 | 22 | 60 | 25TQC22MD2 | |
| | | | | | | POSCAP TQS | D15 | 105 | 35 | 47 | 100 | 35TQS47MEX | |
| POSCAP TQC | | | | | | D2 | 105 | 25 | 15 | 90 | 25TQC15MD2 | | |
| OS-CON SVPD | | | | | | C6 | 125 | 25 | 10 | 65 | 25SVPD10M | | |
| Hybrid ZA | | | | | | C | 105 | 35 | 10 | 100 | EEHZA1V100R | | |
| 105 | 25 | 15 | 40 | EEFCS1E150R | POSCAP TQC | D2 | 105 | 25 | 22 | 60 | 25TQC22MD2 | | |
| | | | | | POSCAP TQS | D15 | 105 | 35 | 47 | 100 | 35TQS47MEX | | |
| | | | | | POSCAP TQC | D2 | 105 | 25 | 15 | 90 | 25TQC15MD2 | | |
| | | | | | OS-CON SVPK | B6 | 125 | 25 | 33 | 35 | 25SVPK33M | | |
| 105 | 35 | 10 | 40 | EEFCS1V100R | Hybrid ZA | C | 105 | 25 | 22 | 80 | EEHZA1E220R | | |
| | | | | | POSCAP TQC | D2 | 105 | 35 | 10 | 180 | 35TQC10MD2 | | |
| | | | | | OS-CON SVPK | B6 | 125 | 35 | 22 | 35 | 35SVPK22M | | |
| CT | 105 | 10 | 68 | 40 | EEFCT1A680R | POSCAP TQC | D15 | 105 | 16 | 47 | 55 | 16TQC47MYFT | |
| | | | | | | POSCAP TPC | D2 | 105 | 10 | 100 | 45 | 10TPC100M | |
| | | | | | | OS-CON SVPC | B6 | 105 | 10 | 68 | 30 | 10SVPC68M | |
| | | | | | | Hybrid ZA | D8 | 105 | 25 | 68 | 30 | EEHZA1E680XP | |
| | | | | | | Hybrid ZA | D8 | 105 | 35 | 68 | 35 | EEHZA1V680XP | |
| | 105 | 16 | 47 | 40 | EEFCT1C470R | POSCAP TQC | D15 | 105 | 16 | 47 | 55 | 16TQC47MYFT | |
| | | | | | | OS-CON SVF | B6 | 125 | 16 | 82 | 27 | 16SVF82M | |
| | | | | | | Hybrid ZA | D | 105 | 25 | 47 | 50 | EEHZA1E470P | |
| | 105 | 20 | 33 | 40 | EEFCT1D330R | POSCAP TQC | D15 | 105 | 20 | 47 | 55 | 20TQC47MYFT | |
| | | | | | | OS-CON SVPK | B6 | 125 | 25 | 33 | 35 | 25SVPK33M | |
| | | | | | | Hybrid ZA | C | 105 | 25 | 33 | 80 | EEHZA1E330R | |
| | 105 | 20 | 47 | 40 | EEFCT1D470R | POSCAP TQC | D15 | 105 | 20 | 47 | 55 | 20TQC47MYFT | |
| | | | | | | OS-CON SVPF | C6 | 105 | 25 | 47 | 30 | 25SVPF47M | |
| | | | | | | Hybrid ZA | D | 105 | 25 | 47 | 50 | EEHZA1E470P | |
| | 105 | 25 | 22 | 40 | EEFCT1E220R | POSCAP TQC | D15 | 105 | 25 | 22 | 70 | 25TQC22MD2 | |
| | | | | | | POSCAP TQS | D15 | 105 | 35 | 47 | 100 | 35TQS47MEX | |
| | | | | | | OS-CON SVPF | B6 | 105 | 25 | 27 | 40 | 25SVPF27MX | |
| | | | | | | Hybrid ZA | C | 105 | 25 | 22 | 80 | EEHZA1E220R | |
| | 105 | 35 | 15 | 40 | EEFCT1V150R | POSCAP TQC | D2 | 105 | 35 | 15 | 150 | 35TQC15MD2 | |
| | | | | | | OS-CON SVPK | B6 | 125 | 35 | 22 | 35 | 35SVPK22M | |
| | | | | | | | Hybrid ZA | C | 105 | 35 | 22 | 100 | EEHZA1V220R |

Replacement list for “Not recommended for new design”

* If you are using any of the following models on the deleted list, please substitute them with the suggested alternative model as soon as possible.

| Non-recommended part number | | | | | | Replacement part number | | | | | | |
|-----------------------------|---------------------------------|-------------------|-------------------|-------------|-------------|-------------------------|-----------|---------------------------------|-------------------|-------------------|-----------------------------|------------------------------|
| Series | Cate-gory temp. range max. (°C) | Rated voltage (V) | Capaci-tance (μF) | ESR (mΩ) | Part number | Series | Size code | Cate-gory temp. range max. (°C) | Rated voltage (V) | Capaci-tance (μF) | ESR (mΩ) | Part number |
| CX | 105 | 10 | 100 | 40 | EEFCX1A101R | POSCAP TPC | D2 | 105 | 10 | 100 | 45 | 10TPC100M |
| | | | | | | OS-CON SVPC | C6 | 105 | 10 | 120 | 22 | 10SVPC120MV |
| | | | | | | Hybrid ZA | D8 | 105 | 25 | 100 | 30 | EEHZA1E101XP |
| | 105 | 10 | 47 | 40 | EEFCX1A470R | POSCAP TPE | D2E | 105 | 10 | 68 | 25 | 10TPC100M |
| | | | | | | POSCAP TPE | B2 | 85 | 10 | 47 | 35 | 10TPE47MAZB |
| | | | | | | OS-CON SVP | C6 | 105 | 10 | 47 | 50 | 10SVP47M |
| | 105 | 10 | 68 | 40 | EEFCX1A680R | Hybrid ZA | D | 105 | 25 | 47 | 50 | EEHZA1E470P |
| | | | | | | POSCAP TPC | D2 | 105 | 10 | 100 | 45 | 10TPC100M |
| | | | | | | POSCAP TQC | D2 | 105 | 16 | 68 | 50 | 16TQC68MD2 |
| | | | | | | OS-CON SVPC | B6 | 105 | 10 | 68 | 23 | 10SVPC68MV |
| | 105 | 16 | 15 | 40 | EEFCX1C150R | Hybrid ZA | D8 | 105 | 25 | 68 | 30 | EEHZA1E680XP |
| | | | | | | Hybrid ZA | D8 | 105 | 35 | 68 | 35 | EEHZA1V680XP |
| | | | | | | POSCAP TQC | D2 | 105 | 16 | 47 | 55 | 16TQC47MD2 |
| | | | | | | POSCAP TQC | B2 | 105 | 25 | 15 | 100 | 25TQC15MB |
| | 105 | 16 | 22 | 40 | EEFCX1C220R | OS-CON SVP | B6 | 105 | 16 | 22 | 90 | 16SVP22M |
| | | | | | | Hybrid ZA | C | 105 | 25 | 22 | 80 | EEHZA1E220R |
| | | | | | | POSCAP TQC | B2 | 105 | 16 | 33 | 90 | 16TQC33MB2 |
| | 105 | 16 | 33 | 40 | EEFCX1C330R | OS-CON SVPC | B6 | 105 | 16 | 39 | 27 | 16SVPC39MV |
| | | | | | | Hybrid ZA | C | 105 | 25 | 33 | 80 | EEHZA1E330R |
| | | | | | | OS-CON SVPF | B6 | 105 | 16 | 82 | 27 | 16SVPF82M |
| | 105 | 16 | 47 | 40 | EEFCX1C470R | Hybrid ZA | D | 105 | 25 | 47 | 50 | EEHZA1E470P |
| | | | | | | POSCAP TQC | D2 | 105 | 16 | 68 | 50 | 16TQC68MD2 |
| | 105 | 16 | 68 | 40 | EEFCX1C680R | POSCAP TQC | D2 | 105 | 16 | 100 | 50 | 16TQC100MD2 |
| | | | | | | OS-CON SVPC | C6 | 105 | 16 | 68 | 25 | 16SVPC68MV |
| | | | | | | Hybrid ZA | D8 | 105 | 25 | 68 | 30 | EEHZA1E680XP |
| | | | | | | Hybrid ZA | D8 | 105 | 35 | 68 | 35 | EEHZA1V680XP |
| | 105 | 20 | 22 | 40 | EEFCX1D220R | POSCAP TQC | D2 | 105 | 20 | 33 | 60 | 20TQC33MD2 |
| | | | | | | POSCAP TQC | B2 | 105 | 20 | 22 | 90 | 20TQC22MB2 |
| | | | | | | OS-CON SVPA | C6 | 105 | 20 | 22 | 35 | 20SVPA22M |
| | | | | | | Hybrid ZA | C | 105 | 25 | 22 | 80 | EEHZA1E220R |
| | 105 | 20 | 33 | 40 | EEFCX1D330R | POSCAP TQC | D2 | 105 | 20 | 33 | 60 | 20TQC33MD2 |
| | | | | | | POSCAP TQC | D2 | 105 | 20 | 47 | 55 | 20TQC47MD2 |
| | | | | | | OS-CON SVPK | B6 | 125 | 25 | 33 | 35 | 25SVPK33M |
| | 105 | 20 | 47 | 40 | EEFCX1D470R | Hybrid ZA | C | 105 | 25 | 33 | 80 | EEHZA1E330R |
| | | | | | | POSCAP TQC | D15 | 105 | 20 | 47 | 55 | 20TQC47MYFT |
| | | | | | | OS-CON SVPF | C6 | 105 | 25 | 47 | 30 | 25SVPF47M |
| | 105 | 20 | 56 | 40 | EEFCX1D560R | Hybrid ZA | D | 105 | 25 | 47 | 50 | EEHZA1E470P |
| | | | | | | POSCAP TQC | D2 | 105 | 20 | 100 | 100 | 20TQC100MD2 |
| | 105 | 25 | 15 | 40 | EEFCX1E150R | OS-CON SVPF | B6 | 105 | 20 | 56 | 30 | 20SVPF56MX |
| | | | | | | Hybrid ZA | C | 105 | 25 | 56 | 50 | EEHZA1E560P |
| | | | | | | POSCAP TQC | B2 | 105 | 25 | 15 | 100 | 25TQC15MB |
| | 105 | 25 | 22 | 40 | EEFCX1E220R | OS-CON SVPK | B6 | 125 | 25 | 33 | 35 | 25SVPK33M |
| | | | | | | Hybrid ZA | C | 105 | 25 | 22 | 80 | EEHZA1E220R |
| | | | | | | POSCAP TQC | D2 | 105 | 25 | 22 | 60 | 25TQC22MD2 |
| | 105 | 25 | 33 | 40 | EEFCX1E330R | OS-CON SVPF | B6 | 105 | 25 | 27 | 40 | 25SVPF27M |
| | | | | | | Hybrid ZA | C | 105 | 25 | 22 | 80 | EEHZA1E220R |
| | | | | | | POSCAP TQC | D2 | 105 | 25 | 22 | 60 | 25TQC22MD2 |
| | 105 | 35 | 15 | 40 | EEFCX1V150R | OS-CON SVPK | B6 | 125 | 25 | 33 | 35 | 25SVPK33M |
| Hybrid ZA | | | | | | C | 105 | 25 | 33 | 80 | EEHZA1E330R | |
| POSCAP TQC | | | | | | D2 | 105 | 35 | 15 | 150 | 35TQC15MD2 | |
| 105 | 35 | 22 | 40 | EEFCX1V220R | OS-CON SVPK | B6 | 125 | 35 | 22 | 35 | 35SVPK22M | |
| | | | | | Hybrid ZA | C | 105 | 35 | 22 | 100 | EEHZA1V220R | |
| | | | | | POSCAP TQC | D2 | 105 | 35 | 15 | 150 | 35TQC15MD2 | |
| | | | | | | | | | | | | 35SVPK22M |
| | | | | | | | | | | | | EEHZA1V220R |

Replacement list for “Not recommended for new design”

* If you are using any of the following models on the deleted list, please substitute them with the suggested alternative model as soon as possible.

| Non-recommended part number | | | | | | Replacement part number | | | | | | |
|-----------------------------|---------------------------------|-------------------|-------------------|-------------|--------------|-------------------------|-----------|---------------------------------|-------------------|-------------------|-----------------------------|------------------------------|
| Series | Cate-gory temp. range max. (°C) | Rated voltage (V) | Capaci-tance (μF) | ESR (mΩ) | Part number | Series | Size code | Cate-gory temp. range max. (°C) | Rated voltage (V) | Capaci-tance (μF) | ESR (mΩ) | Part number |
| HX | 125 | 10 | 47 | 40 | EEFHX1A470R | POSCAP TDC | D2 | 125 | 16 | 100 | 50 | 16TDC100MD2 |
| | | | | | | OS-CON SVPD | C6 | 125 | 10 | 56 | 45 | 10SVPD56M |
| | | | | | | Hybrid ZC | D | 125 | 25 | 47 | 50 | EEHXC1E470P |
| | 125 | 10 | 68 | 40 | EEFHX1A680R | POSCAP TDC | D2 | 125 | 16 | 100 | 50 | 16TDC100MD2 |
| | | | | | | OS-CON SVPK | B6 | 125 | 20 | 68 | 30 | 20SVPK68M |
| | | | | | | Hybrid ZC | D8 | 125 | 25 | 68 | 30 | EEHXC1E680XP |
| | 125 | 10 | 100 | 40 | EEFHX1A101R | POSCAP TDC | D2 | 125 | 16 | 100 | 50 | 16TDC100MD2 |
| | | | | | | POSCAP TCF | D3L | 105 | 10 | 150 | 15 | 10TCF150ML |
| | | | | | | OS-CON SVPK | B6 | 125 | 16 | 100 | 27 | 16SVPK100M |
| | | | | | | Hybrid ZC | D8 | 125 | 25 | 100 | 30 | EEHXC1E101XP |
| | 125 | 16 | 15 | 40 | EEFHX1C150R | POSCAP TDC | D2 | 125 | 16 | 100 | 50 | 16TDC100MD2 |
| | | | | | | POSCAP TDC | B2 | 125 | 16 | 33 | 90 | 16TDC33MB2 |
| | | | | | | Hybrid ZC | C | 125 | 25 | 22 | 80 | EEHXC1E220R |
| | 125 | 16 | 22 | 40 | EEFHX1C220R | POSCAP TDC | D2 | 125 | 16 | 100 | 50 | 16TDC100MD2 |
| | | | | | | POSCAP TDC | B2 | 125 | 16 | 33 | 90 | 16TDC33MB2 |
| | | | | | | OS-CON SVPK | B6 | 125 | 35 | 22 | 35 | 35SVPK22M |
| | | | | | | Hybrid ZC | C | 125 | 25 | 22 | 80 | EEHXC1E220R |
| | 125 | 16 | 33 | 40 | EEFHX1C330R | POSCAP TDC | D2 | 125 | 16 | 100 | 50 | 16TDC100MD2 |
| | | | | | | POSCAP TDC | B2 | 125 | 16 | 33 | 90 | 16TDC33MB2 |
| | | | | | | OS-CON SVPK | B6 | 125 | 25 | 33 | 35 | 25SVPK33M |
| | | | | | | Hybrid ZC | C | 125 | 25 | 33 | 80 | EEHXC1E330R |
| | 125 | 16 | 47 | 40 | EEFHX1C470R | POSCAP TDC | D2 | 125 | 16 | 100 | 50 | 16TDC100MD2 |
| | | | | | | OS-CON SVPK | C6 | 125 | 35 | 47 | 27 | 35SVPK47M |
| | | | | | | Hybrid ZC | D | 125 | 25 | 47 | 50 | EEHXC1E470P |
| | 125 | 16 | 68 | 40 | EEFHX1C680R | POSCAP TDC | D2 | 125 | 16 | 100 | 50 | 16TDC100MD2 |
| | | | | | | OS-CON SVF | B6 | 125 | 16 | 82 | 27 | 16SVF82M |
| | | | | | | Hybrid ZC | D8 | 125 | 25 | 68 | 30 | EEHXC1E680XP |
| | 125 | 20 | 22 | 40 | EEFHX1D220R | POSCAP TDC | B2 | 125 | 20 | 22 | 90 | 20TDC22MB2 |
| | | | | | | OS-CON SVPK | B6 | 125 | 35 | 22 | 35 | 35SVPK22M |
| | | | | | | Hybrid ZC | C | 125 | 25 | 22 | 80 | EEHXC1E220R |
| | 125 | 20 | 33 | 40 | EEFHX1D330R | OS-CON SVPK | B6 | 125 | 25 | 33 | 35 | 25SVPK33M |
| | | | | | | Hybrid ZC | C | 125 | 25 | 33 | 80 | EEHXC1E330R |
| | 125 | 20 | 47 | 40 | EEFHX1D470R | OS-CON SVPK | C6 | 125 | 35 | 47 | 27 | 35SVPK47M |
| | | | | | | Hybrid ZC | D | 125 | 25 | 47 | 50 | EEHXC1E470P |
| | 125 | 20 | 56 | 40 | EEFHX1D560R | OS-CON SVF | B6 | 125 | 20 | 56 | 30 | 20SVF56M |
| | | | | | | Hybrid ZC | D | 125 | 25 | 56 | 50 | EEHXC1E560P |
| | 125 | 25 | 15 | 40 | EEFHX1E150R | POSCAP TDC | D3L | 125 | 25 | 68 | 70 | 25TDC68MD3 |
| | | | | | | POSCAP TDC | B2 | 125 | 25 | 15 | 100 | 25TDC15MB |
| | | | | | | OS-CON SVF | B6 | 125 | 25 | 27 | 40 | 25SVF27M |
| | | | | | | Hybrid ZC | C | 125 | 25 | 22 | 80 | EEHXC1E220R |
| | 125 | 25 | 22 | 40 | EEFHX1E220R | POSCAP TDC | D3L | 125 | 25 | 68 | 70 | 25TDC68MD3 |
| | | | | | | OS-CON SVF | B6 | 125 | 25 | 27 | 40 | 25SVF27M |
| Hybrid ZC | | | | | | C | 125 | 25 | 22 | 80 | EEHXC1E220R | |
| 125 | 25 | 33 | 40 | EEFHX1E330R | POSCAP TDC | D3L | 125 | 25 | 68 | 70 | 25TDC68MD3 | |
| | | | | | OS-CON SVPK | B6 | 125 | 25 | 33 | 35 | 25SVPK33M | |
| | | | | | Hybrid ZC | C | 125 | 25 | 33 | 80 | EEHXC1E330R | |
| SX | 105 | 4 | 82 | 9 | EEFSX0G820ER | SP-Cap SX | D | 105 | 4 | 220 | 9 | EEFSX0G221ER |
| | 105 | 4 | 100 | 9 | EEFSX0G101ER | | | | | | | |
| | 105 | 4 | 150 | 9 | EEFSX0G151ER | | | | | | | |
| | 105 | 4 | 150 | 7 | EEFSX0G151E7 | | | | | | | |

Conductive Polymer Tantalum Solid Capacitors

POSCAP™

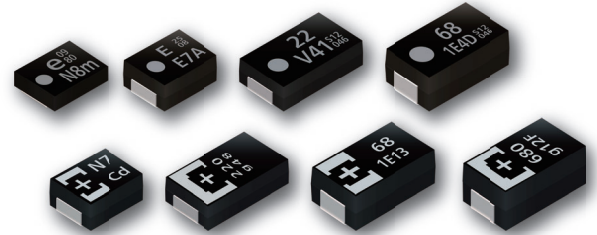

INDEX

| | |
|--|---------------------|
| Application Guidelines (POSCAP) | P48 |
| Line-up / Diagram | P50 |
| Voltage - Capacitance table | P53 |
| Explanation of part numbers | P57 |
| Mounting / Packing specifications | P58 |
| Each series | P60 |
| Catalog Deletion Models / EOL Models | P87 |

Applications

Main market

Laptop computer

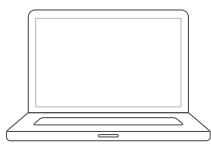

Communications infrastructure

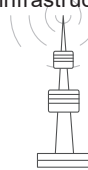

SSD, HDD



Audio / Visual

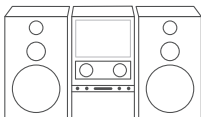

Server



Automotive

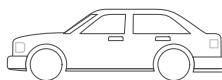

Industrial robot

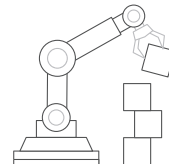

Drone



Matters to Be Observed When Using This Product (Conductive Polymer Tantalum Solid Capacitors / POSCAP)

Use environments and cleaning conditions

- This product (capacitor) is intended for standard general-purpose use in electronic equipment, and is not designed for use in the specific environments described below. Using the product in such specific environments or service conditions, therefore, may affect the performance of the product.

Please check with us about the performance and reliability of the product first before using the product.

- (1) Used in liquid, such as water, oil, chemicals, and organic solvents.
 - (2) Used in a place exposed to direct sunlight, an outdoor place with no shielding, or a dusty place.
 - (3) Used in a wet place (dew concentration on a resistor, water leakage, etc.), a place exposed to sea breeze, or a place filled with a corrosive gas, such as Cl_2 , H_2S , NH_3 , SO_2 , or NO_x .
 - (4) Used in an environment where static electricity and electromagnetic waves are strong.
 - (5) The product is located close to a heating component or a flammable material, such as a vinyl cable, is placed near the product.
 - (6) The product is used sealed with a resin, etc.
 - (7) Solder flux of the soldered product is cleansed with a solvent, water, and a water-soluble cleaner.
(Be careful with water soluble solder flux.)
 - (8) Used in an environment where an acidic or alkali atmosphere is present.
 - (9) Used in an environment where excessive vibration or impact is applied to the product.
 - (10) Used under a low atmospheric pressure condition or depressurized condition.
- When the capacitor is used in a circuit where an impact voltage is applied or a high voltage is applied in a short period (transient phenomenon) or a high pulse voltage is applied, make sure to use the capacitor at a voltage equal to or lower than its rated voltage.

Response to anomalies and handling conditions

- A short mode is a major failure mode in a capacitor. A short mode is caused by thermal stress created by soldering or a high service temperature, electric stress, mechanical stress, etc. When the capacitor has shorted, take the following steps to ensure your safety.
 - (1) When you see smoke coming out of the shorted product, turn off the main power supply to stop using the capacitor.
Do not place your face or hand near to the smoldering capacitor.
 - (2) The time a shorted capacitor takes to generate smoke ranges from a few seconds to a few minutes, depending on service conditions. If you incorporate a protective circuit, design the circuit to activate in the time preceding the smoke generation.
 - (3) In case smoke gets into your eyes or comes into your mouth, wash the eyes with water or rinse out the mouth immediately.
 - (4) When a current value after the short of the product is extremely large, the shorted capacitor may spark out, which, in the worst scenario, may result in ignition. Ensure the safety of the circuit by, for example, giving it a redundant circuit structure or providing it with a protective circuit.

Reliability and product life

The failure rate of the capacitor is specified based on $0.5\% \cdot 1000 \text{ h}$ (reliability level 60%), a failure rate conforming to JIS C 5003 (failure rate level). This indicates that the possibility of occurrence of a failure is by no means zero. One of the failure modes is a wear out failure. This happens when the period of guaranteeing the durability and high-temperature/high-humidity resistance of the capacitor is over, changes in the electrical characteristics of the capacitor (product) get larger and its electrolyte gradually deteriorates into an insulating material to create an open mode. Another failure mode is a random failure in which a short mode results mainly because of thermal, electrical, or mechanical stress, etc.

* The failure rate of a small POSCAP of a B2 size or smaller is 1.0%.

Circuit design and circuit board design

- Do not use this capacitor in a high-impedance voltage holding circuit, a coupling circuit, a time constant circuit, or a circuit widely affected by leak current.
- The capacitor is incorporated and used in a circuit where the capacitor operates within a rating range specified in the specifications. Set a service temperature within a specified category temperature range. Do not let a current larger than the allowable ripple current flow in the circuit. Reduce a ripple current to the extent at which the surface temperature of the capacitor's top does not exceed the rated temperature.
(For information about TQC series, please contact us separately.)
- Electrical characteristics values listed in a characteristics table, such as a capacitance and an ESR, are values specified at shipment of the capacitor. These values may change when departing from the specified values in the table under certain electrical or mechanical performance condition. Be careful in choosing a capacitor with the intended electrical characteristics in your design work. Besides, temperature/frequency fluctuations can cause the capacitor's electrical characteristics to change. Confirm such changes in the electrical characteristics and then proceed with your circuit design.
- A leak current may increase even when soldering conditions are within a specified range. The leak current may increase also in a high-temperature non-load test or humidity-resistance non-load test, in which no voltage is applied, a temperature cycle test, etc. In such cases, applying a voltage at a temperature equal to or lower than the highest service temperature of the capacitor reduces the leak current gradually.
- A flow of excessively large rush current created by rapid charge/discharge may result in short circuit or an increase in leak current. When a rush current value exceeds 20 A*, apply a protective circuit to the product.
Note that at leak current measurement, a protective resistance of about 1 kΩ is put in the circuit before the capacitance is charged or discharges.

Mounting and storage conditions

- Set soldering conditions within a specified range. Stricter soldering conditions outside the specified range will cause the deterioration of the electrical characteristics and service life characteristics.
- The capacitor must be kept in storage in an environment that avoids dropping soldering performance or caused trouble with soldering because of moisture absorption by an exterior resin. Store the capacitor, which is put together with a reel in an airtight moisture-proof bag, in a place where a normal temperature and humidity (15 °C to 35 °C and 45%RH to 75%RH) are maintained and direct sunlight is blocked. The storage period is 18 months or less after shipment from the factory.
- Unseal the bag to take out the capacitor right before mounting it on a circuit. Once you take out the capacitor, make sure to use it up. Storage periods for capacitors taken out of bags are as follows.

* These products do not conform to the entire requirements defined in JEDEC J-STD-020 and J-STD-033.

- (1) Level 2a : four weeks at a temperature and a humidity equal to or lower than 30 °C and 60 %RH
- (2) Level 3 : 168 hours at a temperature and a humidity equal to or lower than 30 °C and 60 %RH
- (3) Level 5 : 48 hours at a temperature and a humidity equal to or lower than 30 °C and 60 %RH

Reference information

Intellectual property

Panasonic Group provides customers with safe products and services. We are also making great efforts to protect our intellectual property rights for Panasonic Group products. Typical patents related to this product are as follows.

[U.S. patent]

USP Nos. 8081421, 8149569, 8456804, and 8559166

Line up

| Series | Features | Small size/Low profile | Large capacitance | Low ESR | High reliability | High voltage | Guaranteed at 125°C | Category temp. range (°C) | Rated voltage (V) | ESR (mΩ) | Capacitance (μF) | Size code | Size (mm) | | |
|-------------------|---|------------------------|-------------------|---------|------------------|--------------|---------------------|---------------------------|-------------------|-----------|------------------|-----------|-----------|-----|-----|
| | | | | | | | | | | | | | L | W | H |
| TPS | Small size/Low profile Large capacitance Face down terminal | ● | ● | | | | | -55 to 105 | 2.5 to 6.3 | 30 to 35 | 150 to 330 | B1S | 3.5 | 2.8 | 1.1 |
| TPSF | Low ESR/Small size Large capacitance Face down terminal | ● | ● | ● | | | | -55 to 105 | 2.0 to 2.5 | 6 to 9 | 270 | B2S | 3.5 | 2.8 | 1.9 |
| TPE ^{*1} | Low ESR | | | | | | | -55 to 105 | 2.0 to 10 | 9 to 70 | 47 to 470 | B2 | 3.5 | 2.8 | 1.9 |
| | | | | | | | | -55 to 105 | 2.5 to 10 | 7 to 45 | 68 to 470 | D2E | 7.3 | 4.3 | 1.8 |
| | | | | | | | | -55 to 105 | 2.5 to 10 | 9 to 40 | 150 to 680 | D3L | 7.3 | 4.3 | 2.8 |
| | | | | | | | | -55 to 105 | 2.5 to 10 | 10 to 40 | 330 to 1500 | D4 | 7.3 | 4.3 | 3.8 |
| TPF ^{*1} | Low ESR Large capacitance | | | | | | | -55 to 105 | 2.5 to 10 | 5 to 25 | 150 to 680 | D3L | 7.3 | 4.3 | 2.8 |
| | | | | | | | | -55 to 105 | 2.5 to 6.3 | 5 to 35 | 470 to 1000 | D4 | 7.3 | 4.3 | 3.8 |
| TQT | Super high voltage Low profile Large capacitance | ● | ● | | | | | -55 to 105 | 35 | 100 | 56 | D15S | 7.3 | 4.3 | 1.4 |
| TQS | High voltage | ● | | | | | | -55 to 105 | 35 | 100 | 47 | D15S | 7.3 | 4.3 | 1.4 |
| | | | | | | | | -55 to 105 | 35 | 100 | 68 | D2S | 7.3 | 4.3 | 1.9 |
| UPDATE | High voltage | | | | | | | -55 to 105 | 16 to 35 | 90 to 200 | 10 to 47 | B2 | 3.5 | 2.8 | 1.9 |
| | | | | | | | | -55 to 105 | 16 to 25 | 55 to 70 | 22 to 47 | D15 | 7.3 | 4.3 | 1.4 |
| | | | | | | | | -55 to 105 | 16 to 35 | 50 to 180 | 10 to 150 | D2 | 7.3 | 4.3 | 1.9 |
| | | | | | | | | -55 to 105 | 16 to 25 | 50 to 70 | 68 to 220 | D3L | 7.3 | 4.3 | 2.8 |
| TA | High reliability | | | | | | | -55 to 105 | 4.0 to 10 | 70 | 47 to 100 | B2 | 3.5 | 2.8 | 1.9 |
| | | | | | | | | -55 to 105 | 2.5 to 6.3 | 9 to 25 | 150 to 470 | D2E | 7.3 | 4.3 | 1.8 |
| | | | | | | | | -55 to 105 | 2.5 to 10 | 15 to 25 | 150 to 680 | D3L | 7.3 | 4.3 | 2.8 |
| TV | High reliability Guaranteed at 125 °C | | | | | | | -55 to 125 | 6.3 to 10 | 25 | 68 to 150 | D2E | 7.3 | 4.3 | 1.8 |
| | | | | | | | | -55 to 125 | 10 | 25 | 150 | D3L | 7.3 | 4.3 | 2.8 |
| TPB ^{*1} | Standard | | | | | | | -55 to 105 | 4.0 to 10 | 70 | 33 to 68 | B2 | 3.5 | 2.8 | 1.9 |
| | | | | | | | | -55 to 105 | 4.0 to 10 | 40 to 55 | 150 to 330 | D3L | 7.3 | 4.3 | 2.8 |
| | | | | | | | | -55 to 105 | 6.3 to 10 | 35 to 40 | 220 to 470 | D4 | 7.3 | 4.3 | 3.8 |

*1 : Some part numbers are not a recommended product

Line up

| Series | Features | Small size/Low profile | Large capacitance | Low ESR | High reliability | High voltage | Guaranteed at 125°C | Category temp. range (°C) | Rated voltage (V) | ESR (mΩ) | Capacitance (μF) | Size code | Size (mm) | | |
|---|--------------------------------------|------------------------|-------------------|---------|------------------|--------------|---------------------|---------------------------|-------------------|-----------|------------------|-----------|-----------|-----|-----|
| | | | | | | | | | | | | | L | W | H |
| NRFND TH | Guaranteed at 125 °C | | | | | | ● | -55 to 125 | 2.5 to 6.3 | 15 to 25 | 150 to 330 | D2E | 7.3 | 4.3 | 1.8 |
| | | | | | | | | -55 to 125 | 2.5 to 10 | 40 to 45 | 68 to 220 | D2 | 7.3 | 4.3 | 1.9 |
| | | | | | | | | -55 to 125 | 4.0 to 6.3 | 40 | 220 to 330 | D3L | 7.3 | 4.3 | 2.8 |
| | | | | | | | | -55 to 125 | 6.3 to 10 | 35 to 40 | 220 to 470 | D4 | 7.3 | 4.3 | 3.8 |
| TC ^{*1} | Guaranteed at 125 °C | | | | | | ● | -55 to 125 | 2.5 | 9 | 330 | B2 | 3.5 | 2.8 | 1.9 |
| | | | | | | | | -55 to 125 | 4.0 to 6.3 | 15 to 25 | 100 to 330 | D2E | 7.3 | 4.3 | 1.8 |
| | | | | | | | | -55 to 125 | 2.5 to 10 | 5 to 25 | 150 to 680 | D3L | 7.3 | 4.3 | 2.8 |
| | | | | | | | | -55 to 125 | 2.5 to 10 | 5 to 25 | 330 to 1000 | D4 | 7.3 | 4.3 | 3.8 |
| UPDATE TDC ^{*1} | High voltage Guaranteed at 125 °C | | | | | | ● ● | -55 to 125 | 16 to 25 | 90 to 100 | 15 to 33 | B2 | 3.5 | 2.8 | 1.9 |
| | | | | | | | | -55 to 125 | 16 to 35 | 50 to 180 | 10 to 100 | D2 | 7.3 | 4.3 | 1.9 |
| | | | | | | | | -55 to 125 | 16 to 25 | 50 to 70 | 68 to 150 | D3L | 7.3 | 4.3 | 2.8 |
| TPC ^{*1} | Low profile | ● | | | | | | -55 to 105 | 10 | 45 to 100 | 68 to 100 | D2 | 7.3 | 4.3 | 1.9 |

*1 : Some part numbers are not a recommended product

NRFND

Not recommended for new design

Series flow chart

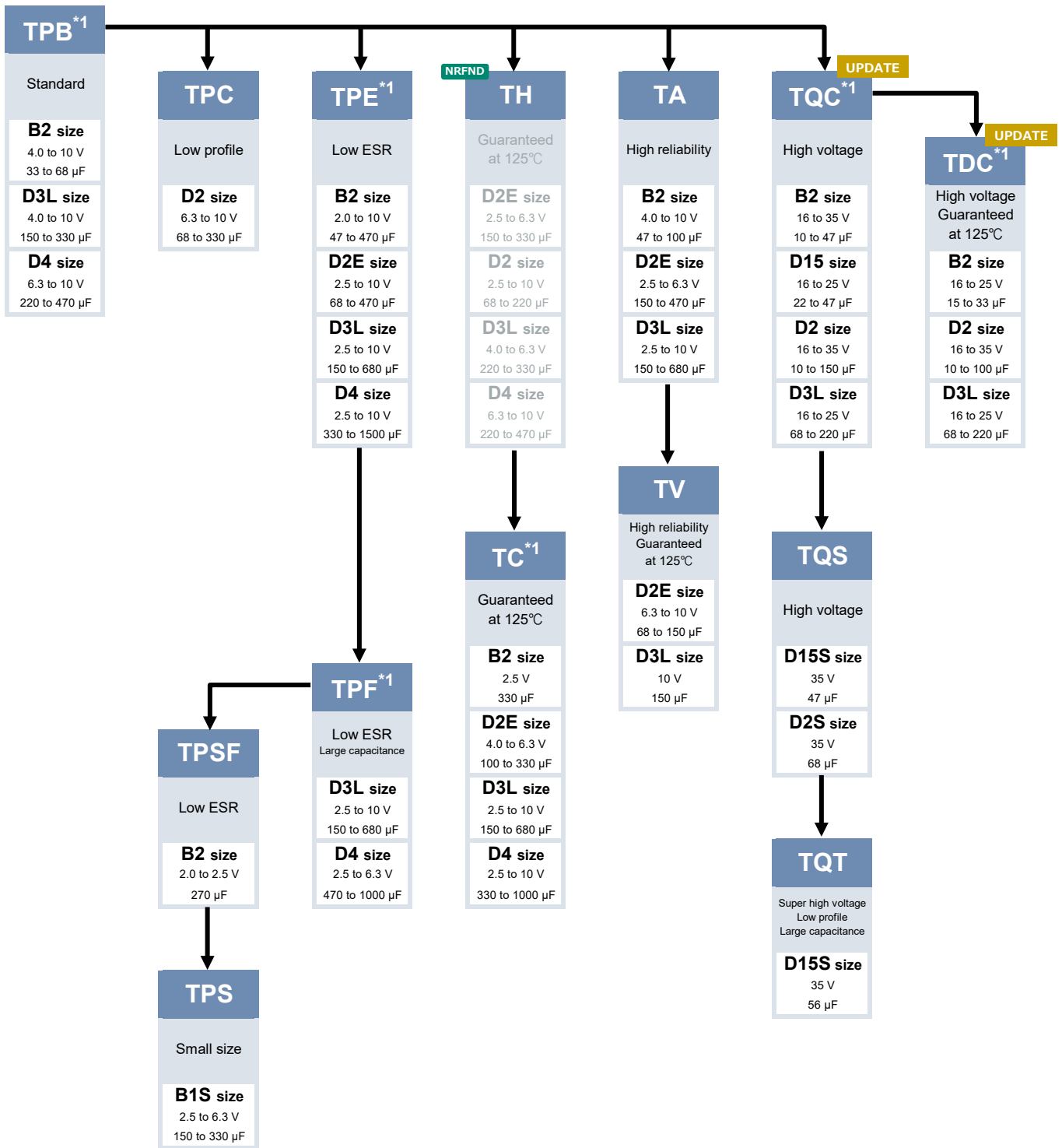

*1: Some part numbers are not a recommended product

NRFND Not recommended for new design

Voltage - Capacitance table (Vol. : 2.0 to 8.0 V / Cap. : 3.9 to 68 μ F)

Series [Size]
(ESR m Ω)

| V | μ F | 3.9 | 4.7 | 5.6 | 6.8 | 8.2 | 10 | 15 | 22 | 33 | 47 | 56 |
|-----|---------|-----|-----|-----|-----|-----|----|----|----|------------------|-----------------|----|
| 2.0 | | | | | | | | | | | | |
| | | | | | | | | | | | | |
| 2.5 | | | | | | | | | | | | |
| | | | | | | | | | | | | |
| | | | | | | | | | | | | |
| | | | | | | | | | | | | |
| 4.0 | | | | | | | | | | | | |
| | | | | | | | | | | | | |
| | | | | | | | | | | | | |
| | | | | | | | | | | | | |
| 6.3 | | | | | | | | | | TPB [B2] (70) | TA [B2] (70) | |
| | | | | | | | | | | | | |
| | | | | | | | | | | | | |
| | | | | | | | | | | | | |
| | | | | | | | | | | | | |
| | | | | | | | | | | | | |
| | | | | | | | | | | | | |
| | | | | | | | | | | | | |
| 8.0 | | | | | | | | | | | | |
| | | | | | | | | | | | | |

Size list LxWxH (mm)

| | | | | | | | | | |
|-----|-------------|-----|-------------|------|-------------|-----|-------------|-----|-------------|
| B1 | 3.5x2.8x1.1 | B2 | 3.5x2.8x1.9 | D15 | 7.3x4.3x1.4 | D2E | 7.3x4.3x1.8 | D3L | 7.3x4.3x2.8 |
| B1S | 3.5x2.8x1.1 | B2S | 3.5x2.8x1.9 | D15S | 7.3x4.3x1.4 | D2 | 7.3x4.3x1.9 | D4 | 7.3x4.3x3.8 |
| | | | | | | D2S | 7.3x4.3x1.9 | | |

Voltage - Capacitance table (Vol. : 2.0 to 8.0 V / Cap. : 100 to 1500 μF)

Series [Size]
(ESR mΩ)

| V | μF | 68 | 100 | 120 | 150 | 220 | 270 | 330 | 470 | 680 | 1000 | 1500 |
|-----|----|------------------|------------------------------|------------------|-------------------------|------------------------------|---------------------|-----------------------------|-------------------------------|----------------------------|---------------------|---------------------|
| 2.0 | | | | | | | TPSF [B2S] (9,6) | | TPE [B2] (15,11) | | | |
| | | | | | | | | | | | | |
| 2.5 | | | | | | TPS [B1S] (30) | TPSF [B2S] (6) | TPS [B1S] (30) | TPE [D2E] (18,15,12,9,7) | TPE [D3L] (40,15,12) | TPE [D4] (15) | TPE [D4] (15,12) |
| | | | | | | TPE [B2] (35,30,25,21,15) | | TPE [B2] (35,18,9) | TPF [D3L] (10,7,6) | TPF [D3L] (10,9,7,6) | TPF [D4] (6,5) | |
| | | | | | | TPE [D2E] (18,15,9) | | TPE [D2E] (18,15,12,9,7) | TA [D2E] (25,15) | TPF [D4] (25) | TC [D4] (15,6,5) | |
| | | | | | | TA [D2E] (25,15,9) | | TA [D2E] (25,18,15) | | TA [D3L] (25,15) | | |
| | | | | | | | | TC [B2] (9) | | TC [D3L] (15,12,10,7,6) | | |
| 4.0 | | TPB [B2] (70) | TPE [B2] (70,40,35) | | TPE [B2] (35) | TPS [B1S] (35,30) | | TPE [D2E] (40,25,18) | TPE [D3L] (40,25,18,15,12) | TPF [D4] (35,15,10) | | |
| | | | TA [B2] (70) | | TPE [D2E] (18) | TPE [B2] (35) | | TPF [D3L] (15,12,9) | TPF [D3L] (10) | TC [D4] (10) | | |
| | | | | | TC [D2E] (18) | TPE [D2E] (45,25,18,15) | | TC [D2E] (25,18) | TA [D3L] (25,18) | | | |
| | | | | | | TA [D2E] (25,18) | | TC [D3L] (12) | TC [D3L] (25,18,15,12,10) | | | |
| | | | | | | TC [D2E] (25,18,15) | | | | | | |
| 6.3 | | TA [B2] (70) | TPE [B2] (70,45,40,35,25) | TPE [B2] (35) | TPS [B1S] (35,30) | TPE [B2] (35,25) | | TPE [D2E] (25) | TPE [D4] (40,35,25,18) | TPE [D4] (25,18) | | |
| | | TPB [B2] (70) | TPE [D2E] (45,25,18) | | TPE [B2] (35,25) | TPE [D2E] (40,25,18) | | TPE [D3L] (25,18,15) | TPF [D4] (15,10) | TC [D4] (25,18) | | |
| | | | | | TPE [D2E] (25,18,15) | TPE [D3L] (18) | | TPF [D3L] (10,9) | TPB [D4] (35) | | | |
| | | | | | TPF [D3L] (25) | TPF [D3L] (25,15,12) | | TA [D3L] (25) | TC [D4] (25,18,10) | | | |
| | | | | | TA [D2E] (25) | TA [D2E] (25,18) | | TPB [D3L] (45,40) | | | | |
| | | | | | TV [D2E] (25) | TC [D2E] (25,18) | | TPB [D4] (40) | | | | |
| | | | | | TC [D2E] (25,18,15) | TC [D3L] (12) | | TC [D3L] (25,18,15,9) | | | | |
| | | | | | | | | | | | | |
| 8.0 | | | TPE [B2] (35) | | | | | | | | | |
| | | | | | | | | | | | | |

Size list LxWxH (mm)

| | | | | | | | | | |
|-----|-------------|-----|-------------|------|-------------|-----|-------------|-----|-------------|
| B1 | 3.5x2.8x1.1 | B2 | 3.5x2.8x1.9 | D15 | 7.3x4.3x1.4 | D2E | 7.3x4.3x1.8 | D3L | 7.3x4.3x2.8 |
| B1S | 3.5x2.8x1.1 | B2S | 3.5x2.8x1.9 | D15S | 7.3x4.3x1.4 | D2 | 7.3x4.3x1.9 | D4 | 7.3x4.3x3.8 |
| | | | | | | D2S | 7.3x4.3x1.9 | | |

Voltage - Capacitance table (Vol. : 10 to 63 V / Cap. : 3.9 to 68 μ F)

Series [Size]
(ESR m Ω)

| V | μ F | 3.9 | 4.7 | 5.6 | 6.8 | 8.2 | 10 | 15 | 22 | 33 | 47 | 56 |
|----|---------|-----|-----|-----|-----|-----|-----------------------|-------------------|-------------------|-------------------|---------------------|---------------------|
| 10 | | | | | | | | | | TPB [B2] (70) | TPE [B2] (35) | |
| | | | | | | | | | | | TA [B2] (70) | |
| | | | | | | | | | | | TPB [B2] (70) | |
| | | | | | | | | | | | | |
| | | | | | | | | | | | | |
| | | | | | | | | | | | | |
| 16 | | | | | | | | | | TQC [B2] (90) | TQC [B2] (90) | |
| | | | | | | | | | | TDC [B2] (90) | TQC [D15] (55) | |
| | | | | | | | | | | | TQC [D2] (55,70) | |
| | | | | | | | | | | | TDC [D2] (55,70) | |
| 20 | | | | | | | | | TQC [B2] (90) | TQC [D2] (60) | TQC [D15] (55) | |
| | | | | | | | | | TQC [D2] (90) | TQC [B2] (100) | TQC [D2] (55) | |
| | | | | | | | | | TDC [B2] (90) | TDC [D2] (60) | TDC [D2] (55) | |
| 25 | | | | | | | | TQC [B2] (100) | TQC [B2] (100) | TQC [D2] (60) | | |
| | | | | | | | | TQC [D2] (90) | TQC [D2] (60) | TDC [D2] (60) | | |
| | | | | | | | | TDC [B2] (100) | TDC [D2] (60) | | | |
| | | | | | | | | TDC [D2] (90) | | | | |
| 35 | | | | | | | TQC [B2] (200,150) | TQC [D2] (150) | TQC [D2] (150) | | TQS [D15S] (100) | TQT [D15S] (100) |
| | | | | | | | TQC [D2] (120,180) | TDC [D2] (150) | TDC [D2] (150) | | | |
| | | | | | | | TDC [D2] (180) | | | | | |

Size list LxWxH (mm)

| | | | | | | | | | |
|-----|-------------|-----|-------------|------|-------------|-----|-------------|-----|-------------|
| B1 | 3.5x2.8x1.1 | B2 | 3.5x2.8x1.9 | D15 | 7.3x4.3x1.4 | D2E | 7.3x4.3x1.8 | D3L | 7.3x4.3x2.8 |
| B1S | 3.5x2.8x1.1 | B2S | 3.5x2.8x1.9 | D15S | 7.3x4.3x1.4 | D2 | 7.3x4.3x1.9 | D4 | 7.3x4.3x3.8 |
| | | | | | | D2S | 7.3x4.3x1.9 | | |

Voltage - Capacitance table (Vol. : 10 to 63 V / Cap. : 100 to 1500 μ F)

Series [Size]
(ESR m Ω)

| V | μ F | 68 | 100 | 120 | 150 | 220 | 270 | 330 | 470 | 680 | 1000 | 1500 |
|----|---------|-------------------------|------------------------|-----|----------------------|----------------------|-----|------------------|-----|-----|------|------|
| 10 | | TV [D2E] (25) | TPC [D2] (55,50,45) | | TPE [D3L] (25) | TPE [D3L] (25,18) | | TPE [D4] (25) | | | | |
| | | TPC [D2] (100,60,45) | | | TPF [D3L] (15) | TA [D3L] (25) | | TPB [D4] (40) | | | | |
| | | | | | TA [D3L] (25) | TPB [D3L] (40) | | TC [D4] (25) | | | | |
| | | | | | TV [D3L] (25) | TPB [D4] (40) | | | | | | |
| | | | | | TPB [D3L] (55,40) | TC [D3L] (25,18) | | | | | | |
| | | | | | TC [D3L] (15) | | | | | | | |
| | | | | | | | | | | | | |
| 16 | | TQC [D2] (50) | TQC [D2] (50) | | TQC [D2] (50) | TQC [D3L] (50) | | | | | | |
| | | TDC [D2] (50) | TDC [D2] (50) | | TQC [D3L] (50) | | | | | | | |
| | | | | | TDC [D3L] (50) | | | | | | | |
| | | | | | | | | | | | | |
| 20 | | | TQC [D2] (100) | | | | | | | | | |
| | | | TQC [D3L] (55) | | | | | | | | | |
| | | | TDC [D3L] (55) | | | | | | | | | |
| 25 | | TQC [D3L] (70) | TQC [D3L] (60) | | | | | | | | | |
| | | TDC [D3L] (70) | | | | | | | | | | |
| | | | | | | | | | | | | |
| 35 | | TQS [D2S] (100) | | | | | | | | | | |
| | | | | | | | | | | | | |
| | | | | | | | | | | | | |

Size list LxWxH (mm)

| | | | | | | | | | |
|-----|-------------|-----|-------------|------|-------------|-----|-------------|-----|-------------|
| B1 | 3.5x2.8x1.1 | B2 | 3.5x2.8x1.9 | D15 | 7.3x4.3x1.4 | D2E | 7.3x4.3x1.8 | D3L | 7.3x4.3x2.8 |
| B1S | 3.5x2.8x1.1 | B2S | 3.5x2.8x1.9 | D15S | 7.3x4.3x1.4 | D2 | 7.3x4.3x1.9 | D4 | 7.3x4.3x3.8 |
| | | | | | | D2S | 7.3x4.3x1.9 | | |

Explanation of part numbers

◇ Part number system

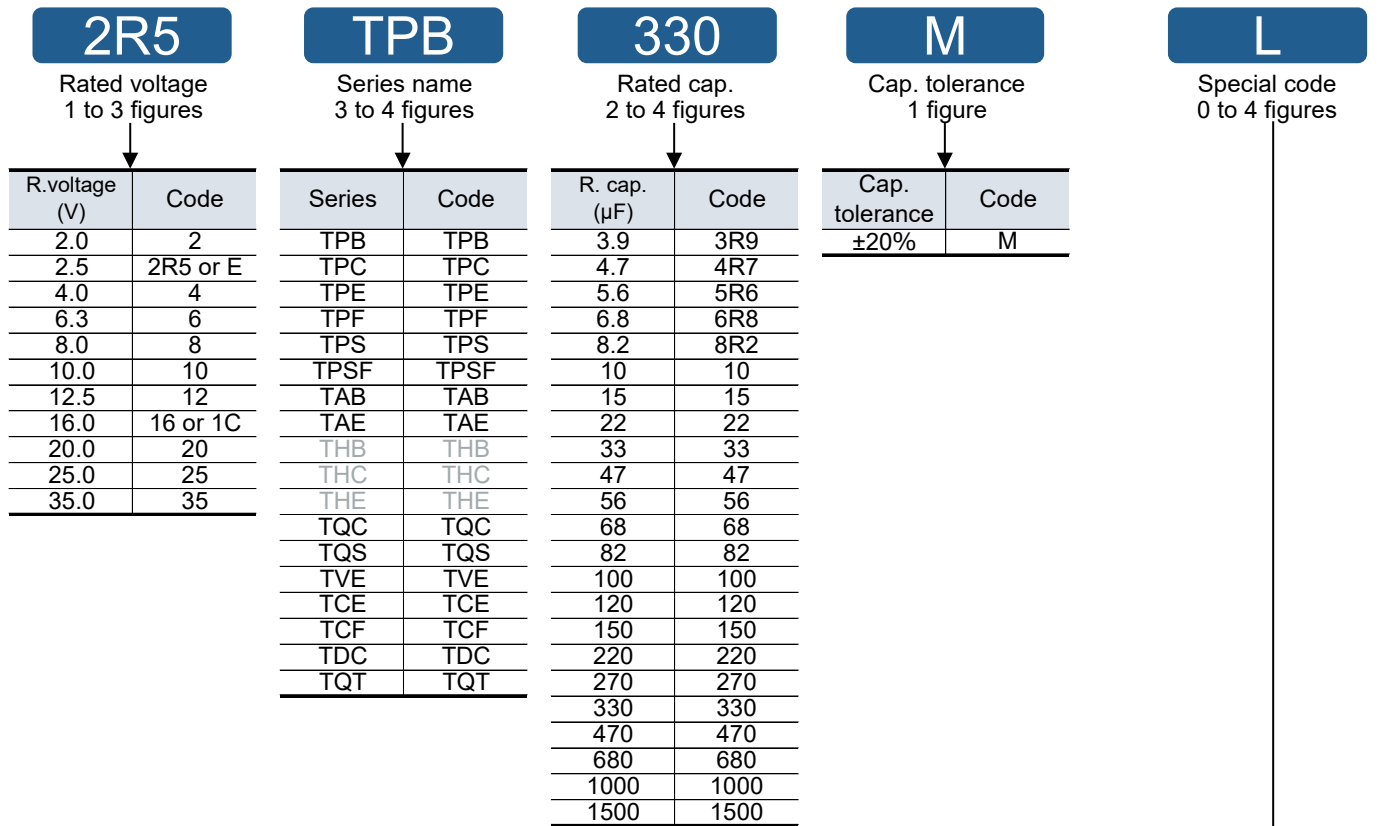

| Standard | | Code |
|------------------|---------------------------------|------|
| TPE series | | |
| B2 | ESR 35 mΩ max. | ZB |
| | ESR 25 mΩ max. | PB |
| | ESR 21 mΩ max. | LB |
| | ESR 15 mΩ max. | FB |
| | ESR 15 mΩ / 300 kHz max. | FGB |
| | ESR 35 mΩ max. 85°C | AZB |
| | ESR 25 mΩ max. 85°C | APB |
| | ESR 15 mΩ max. 85°C | AFB |
| | ESR 13 mΩ / 300 kHz max. 85°C | ADGB |
| | ESR 11 mΩ / 300 kHz max. 85°C | AJGB |
| D2E | ESR 25 mΩ max. 85°C | AP |
| D3L | ESR 25 mΩ max. | L |
| | ESR 18 mΩ max. | IL |
| | ESR 15 mΩ max. | FL |
| | ESR 12 mΩ max. | CL |
| | ESR 10 mΩ max. | AL |
| | ESR 25 mΩ max. 85°C | AL |
| | ESR 9 mΩ / 500 kHz max. 85°C | A9EL |
| TPB series | | |
| | D3L | L |
| TPC series | | |
| | 85 °C | A |
| | B1 | B |
| TQS / TQT series | | |
| D15S | ESR 100 mΩ / Height 1.5 mm max. | EU |
| D2S | ESR 100 mΩ / Height 2.0 mm max. | E2 |

| Standard | | Code |
|--------------------------------------|--------------------------|--------|
| TPF series | | |
| D3L | ESR 9 mΩ max. | 9L |
| | ESR 7 mΩ max. | 7L |
| | ESR 6 mΩ max. | 6L |
| | ESR 5 mΩ max. | 5L |
| D4 | ESR 10 mΩ max. | AH |
| | ESR 6 mΩ max. | 6H |
| | ESR 5 mΩ max. | 5H |
| TQC / TDC series | | |
| Capacitance enlarged type | | YF |
| Capacitance enlarged type (B2 size) | | YFB |
| Capacitance enlarged type (D12 size) | | YFS |
| Capacitance enlarged type (D15 size) | | YFT |
| Capacitance enlarged type (D2 size) | | YFD/D2 |
| Capacitance enlarged type (D3L size) | | D3 |
| All series | | |
| | ESR 55 mΩ max. | G |
| | ESR 45 mΩ max. | V |
| | ESR 40 mΩ max. | W |
| | ESR 35 mΩ max. | Z |
| | ESR 18 mΩ max. | I |
| | ESR 15 mΩ max. | F |
| | ESR 12 mΩ max. | C |
| | ESR 9 mΩ max. | 9 |
| | ESR 7 mΩ max. | 7 |
| | ESR 6 mΩ max. | 6 |
| | ESR 5 mΩ max. | 5 |
| | ESR 35 mΩ / 300 kHz max. | ZG |
| | ESR 30 mΩ / 300 kHz max. | UG |
| | ESR 9 mΩ / 300 kHz max. | 9G |
| | ESR 6 mΩ / 500 kHz max. | 6E |
| | ESR 4 mΩ / 500 kHz max. | 4E |

TPE/TPF/THC/TPC/TQC series some part numbers : Not recommended for new design

Mounting specifications

◆ **Recommendable reflow soldering**

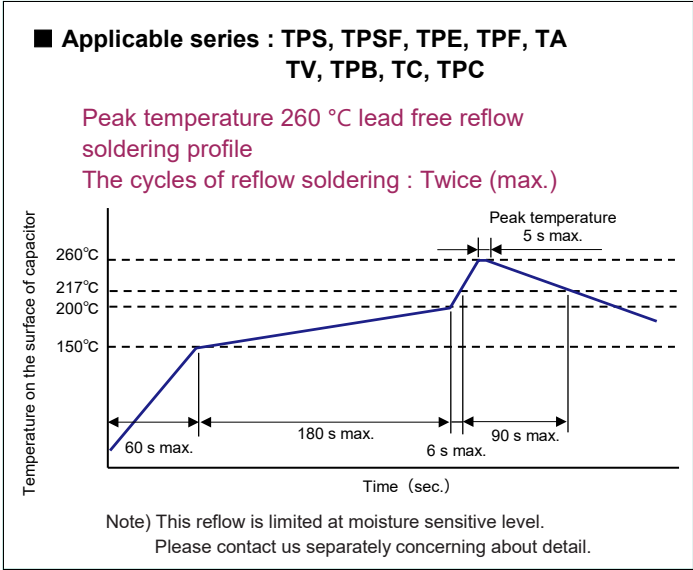
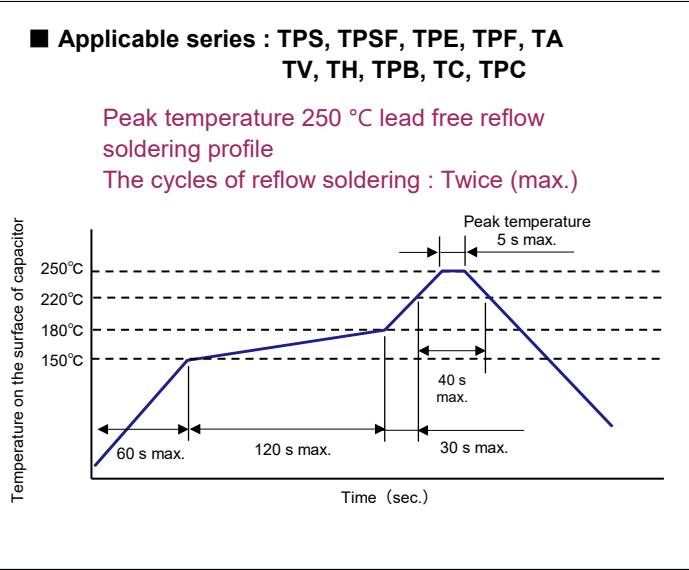

■ **Applicable series : TQC, TDC, TQS, TQT**

* Refer to the characteristics list of each series for compatible part numbers.

| Reflow soldering | Condition A | Condition B | Condition C | Condition D |
|--|-----------------------------------|------------------|--|-----------------|
| | IPC/J-STD-020 reflow profile | | Peak temperature 250 °C lead free reflow profile | |
| Peak temperature (TP) | 260 °C | 250 °C | 250 °C | |
| Time within -5 °C of peak temperature | 30 seconds max. | | - | |
| Soldering time (tL) above soldering temperature (TL) | TL ≥ 217 °C | 150 seconds max. | 90 seconds max. | 60 seconds max. |
| | TL ≥ 200 °C | - | - | 70 seconds max. |
| Preheat | Temperature max. (Tsmáx) | 200 °C | 180 °C | |
| | Temperature min. (Tsmín) | 150 °C | | |
| | Time (ts) from (Tsmín) to (Tsmáx) | 120 seconds max. | | |
| The cycles of reflow soldering | 3 times (max.) | | Twice (max.) | |

● **Soldering with a soldering iron**

Tip of a soldering iron : 350 °C max (TQC / TDC / TQS / TQT series : 400 °C max.)
 Working time : 3 sec. max. (TQC / TQS / TQT series : 5 sec. max.)
 (Do not let the tip of soldering iron touch the POSCAP itself. Do not subject the POSCAP itself to excessive stress when soldering)

Land pattern

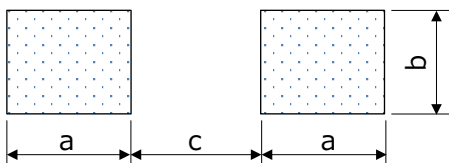

Unit : mm

| Size code | a | b | c |
|-----------------------|-------------|-----|-----|
| B1, B1S, B2, B2S | 1.6 | 2.7 | 1.4 |
| D15, D2E, D2, D3L, D4 | 2.4 | 2.9 | 3.7 |
| D15S | 1.4 / 1.7*1 | 2.6 | 4.6 |
| D2S | 1.4 | 2.6 | 5.1 |

*1 : +side / -side

Packing specifications

◇ Dimension of carrier tape

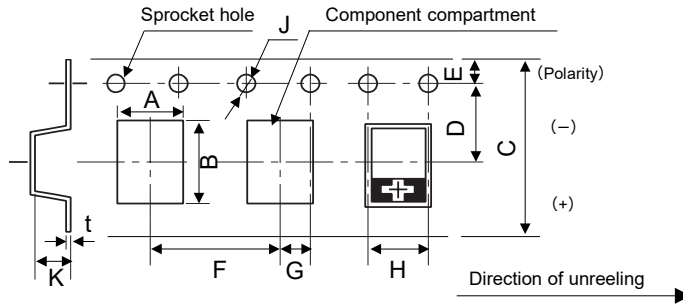

Unit : mm

| Size code | A±0.2 | B±0.2 | C±0.3 | D±0.1 | E±0.1 | F±0.1 | G±0.1 | H±0.1 | J $\begin{smallmatrix} +0.1 \\ -0 \end{smallmatrix}$ | K±0.1 | t±0.1 |
|-----------|-------|-------|-------|-------|-------|-------|-------|-------|--|-------|-------|
| B1 | 3.2 | 3.8 | 8.0 | 3.5 | 1.75 | 4.0 | 2.0 | 4.0 | ø1.5 | 1.4 | 0.25 |
| B1S | 3.25 | 3.9 | 8.0 | 3.5 | 1.75 | 4.0 | 2.0 | 4.0 | ø1.5 | 1.7 | 0.25 |
| B2 | 3.3 | 3.8 | 8.0 | 3.5 | 1.75 | 4.0 | 2.0 | 4.0 | ø1.5 | 2.1 | 0.25 |
| B2S | 3.25 | 4.0 | 8.0 | 3.5 | 1.75 | 4.0 | 2.0 | 4.0 | ø1.5 | 2.1 | 0.25 |
| D12 | 4.5 | 7.5 | 12.0 | 5.5 | 1.75 | 8.0 | 2.0 | 4.0 | ø1.5 | 1.7 | 0.3 |
| D15 | 4.5 | 7.5 | 12.0 | 5.5 | 1.75 | 8.0 | 2.0 | 4.0 | ø1.5 | 2.4 | 0.3 |
| D15S | 4.7 | 7.8 | 12.0 | 5.5 | 1.75 | 8.0 | 2.0 | 4.0 | ø1.5 | 1.7 | 0.3 |
| D2E | 4.5 | 7.5 | 12.0 | 5.5 | 1.75 | 8.0 | 2.0 | 4.0 | ø1.5 | 2.4 | 0.3 |
| D2 | 4.5 | 7.5 | 12.0 | 5.5 | 1.75 | 8.0 | 2.0 | 4.0 | ø1.5 | 2.4 | 0.3 |
| D2S | 4.5 | 7.8 | 12.1 | 5.5 | 1.75 | 8.0 | 2.0 | 4.0 | ø1.5 | 2.4 | 0.3 |
| D3L | 4.5 | 7.7 | 12.0 | 5.5 | 1.75 | 8.0 | 2.0 | 4.0 | ø1.5 | 3.2 | 0.3 |
| D4 | 4.5 | 7.7 | 12.0 | 5.5 | 1.75 | 8.0 | 2.0 | 4.0 | ø1.5 | 4.2 | 0.3 |

- Dimension A and B are the measure of compartment's inside bottom.
- The (+) Polarity of the chip is placed on right side towards the unreeling direction.
- Dimension of the topcover tape.
Thickness of cover tape : 62±10 µm, Width of cover tape : 9.5±0.2 mm 5.5±0.2 mm (ø180)

D12 size : Not recommended for new design

◇ Reel dimension

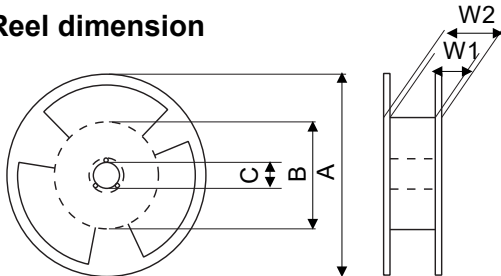

Unit : mm

| A | B | C | W1 | W2 |
|--|-------|-----------|----------|----------|
| ø330±2 | ø80±2 | ø13.0±0.2 | 13.5±0.5 | 17.5±1.0 |
| ø180 $\begin{smallmatrix} 0 \\ -3 \end{smallmatrix}$ | ø60±2 | ø13.0±0.2 | 9.0±0.5 | 11.4±1.0 |

◇ Minimum packing quantity and weight

(ø180)

| Size code | Qty. (pcs./Reel) | Typical weight (g) |
|-----------|------------------|--------------------|
| B1 | 3000 | 200 |
| B1S | 2500 | 200 |
| B2, B2S | 2000 | 200 |

(ø330)

| Size code | Qty. (pcs./Reel) | Typical weight (g) |
|--------------|------------------|--------------------|
| D12 | 4500 | 1200 |
| D15 | 3000 | 1000 |
| D15S | 4000 | 1000 |
| D2E, D2, D2S | 3000 | 1000 |
| D3L | 2500 | 1100 |
| D4 | 2000 | 1200 |

※ Small order quantity (500 pcs/reel) is available with TPE, TPF and TQC series.
Please contact our sales representative if you prefer it.

D12 size : Not recommended for new design

◇ Dimension of packing case

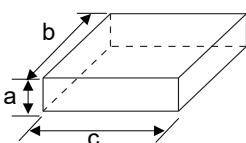

Unit : mm

| Reel size | ø180 | ø330 |
|-----------|------|------|
| a | 90 | 120 |
| b | 240 | 360 |
| c | 240 | 360 |

◇ Units per packing case

| Size code | Pieces/case | Size code | Pieces/case |
|-----------|-------------|--------------|-------------|
| B1 | 15000 | D12 | 22500 |
| B1S | 12500 | D15 | 15000 |
| B2, B2S | 10000 | D15S | 20000 |
| | | D2E, D2, D2S | 15000 |
| | | D3L | 12500 |
| | | D4 | 10000 |

D12 size

: Not recommended for new design

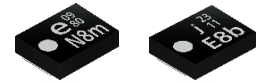

Conductive Polymer Tantalum Solid Capacitors

Surface Mount Type

TPS series

Features

- 105 °C 2000 h
- Small size, Low profile (L 3.5 × W 2.8 × H 1.2 mm max.)
- RoHS compliance, Halogen free

Specifications

| | | |
|-----------------------------|--|--|
| Size code | B1S | |
| Category temp. range | -55 °C to +105 °C | |
| Rated voltage range | 2.5 V to 6.3 V | |
| Category voltage range | 2.5 V to 6.3 V | |
| Rated capacitance range | 150 μF to 330 μF | |
| Capacitance tolerance | ±20 % (120 Hz / +20 °C) | |
| Leakage current | Please see the attached characteristics list | |
| Dissipation factor(tan δ) | Please see the attached characteristics list | |
| Surge voltage (V) | Rated voltage × 1.15 | |
| Endurance | +105 °C 2000 h rated voltage applied | |
| | Capacitance change | Within ±20 % of the initial value |
| | Dissipation factor(tan δ) | ≤ 1.5 times of the initial limit |
| | Leakage current | Within the initial limit |
| Damp heat (Steady State) | +60 °C, 90 % to 95 % RH, 500 h, No-applied voltage | |
| | Capacitance change | Within +40 %, -20 % of the initial value |
| | Dissipation factor(tan δ) | ≤ 1.5 times of the initial limit |
| | Leakage current | ≤ 3 times of the initial limit |

Marking

| R.voltage code | Unit : V | R.capacitance code | Unit : μF |
|----------------|----------|--------------------|-----------|
| e | 2.5 | E8 | 150 |
| g | 4.0 | J8 | 220 |
| j | 6.3 | N8 | 330 |

Dimensions (not to scale)

| Size code | L±0.2 | W±0.2 | H±0.1 | S±0.3 | W1±0.1 |
|-----------|-------|-------|-------|-------|--------|
| B1S | 3.5 | 2.8 | 1.1 | 0.8 | 2.2 |

Unit : mm

* Externals of figure are the reference.

Characteristics list

| Rated voltage (V) | Rated temperature (°C) | Category voltage (V) | Category temperature (°C) | Rated capacitance (μF) | Case size (mm) | | | Size code | Specifications | | | | Standard | | Floor life level | |
|-------------------|------------------------|----------------------|---------------------------|------------------------|----------------|-----|------|-----------|--------------------------------------|----------------------------|--------------------|----------------------|-------------|---------------------------|--------------------|--------------------|
| | | | | | L | W | H | | Ripple current ¹ (mA rms) | ESR ² (mΩ max.) | tan δ ³ | LC ⁴ (μA) | Part number | Min. packaging q'ty (pcs) | Reflow temp ≤260°C | Reflow temp ≤250°C |
| 2.5 | 105 | 2.5 | 105 | 220 | 3.5 | 2.8 | 1.1 | B1S | 1400 | 30 | 0.10 | 55.0 | ETPS220MUD | 2500 | 3 | 3 |
| | 105 | 2.5 | 105 | 330 | 3.5 | 2.8 | 1.1 | | 1400 | 30 | 0.10 | 82.5 | ETPS330MUD | 2500 | | |
| 4.0 | 105 | 4.0 | 105 | 220 | 3.5 | 2.8 | 1.1 | | 1400 | 30 | 0.10 | 88.0 | 4TPS220MUD | 2500 | | |
| | 105 | 6.3 | 105 | 150 | 3.5 | 2.8 | 1.1 | | 1400 | 30 | 0.10 | 94.5 | 6TPS150MUD | 2500 | | |
| 105 | 6.3 | 105 | 3.5 | | 2.8 | 1.1 | 1250 | | 35 | 0.10 | 94.5 | 6TPS150MZD | 2500 | | | |

*1: Ripple current (100 kHz / +45 °C)

*2: ESR (100 kHz / +20 °C)

*3: tan δ (120 Hz / +20 °C)

*4: After 5 minutes

◆ Please refer to each page in this catalog for "Reflow conditions", "Taping specifications" and "Floor life level".

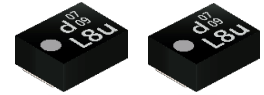

Conductive Polymer Tantalum Solid Capacitors

Surface Mount Type

TPSF series

Features

- Super low ESR (6 mΩ max.)
- Super low ESL (0.7 nH max.)
- Face down terminal type
- RoHS compliance, Halogen free

Specifications

| | | |
|-----------------------------|--|--|
| Size code | B2S | |
| Category temp. range | -55 °C to +105 °C | |
| Rated voltage range | 2.0 V to 2.5 V | |
| Category voltage range | 2.0 V to 2.5 V | |
| Rated capacitance range | 270 μF | |
| Capacitance tolerance | ±20 % (120 Hz / +20 °C) | |
| Leakage current | Please see the attached characteristics list | |
| Dissipation factor(tan δ) | Please see the attached characteristics list | |
| Surge voltage (V) | Rated voltage × 1.15 | |
| Endurance | +105 °C 1000 h rated voltage applied | |
| | Capacitance change | Within ±20 % of the initial value |
| | Dissipation factor(tan δ) | ≤ 1.5 times of the initial limit |
| | Leakage current | Within the initial limit |
| Damp heat (Steady State) | +60 °C, 90 % to 95 % RH, 500 h, No-applied voltage | |
| | Capacitance change | Within +40 %, -20 % of the initial value |
| | Dissipation factor(tan δ) | ≤ 1.5 times of the initial limit |
| | Leakage current | ≤ 3 times of the initial limit |

Marking

Rated voltage code

Polarity marking (+)

Rated capacitance code

Lot. No.

| | |
|----------------|----------|
| R.voltage code | Unit : V |
| d | 2.0 |
| e | 2.5 |

| | |
|--------------------|-----------|
| R.capacitance code | Unit : μF |
| L8 | 270 |

Dimensions (not to scale)

Unit : mm

| Size code | L±0.2 | W±0.2 | H±0.1 | S±0.3 | W1±0.1 |
|-----------|-------|-------|-------|-------|--------|
| B2S | 3.5 | 2.8 | 1.9 | 0.8 | 2.2 |

* Externals of figure are the reference.

Characteristics list

| Rated voltage (V) | Rated temperature (°C) | Category voltage (V) | Category temperature (°C) | Rated capacitance (μF) | Case size (mm) | | | Size code | Specifications | | | | Standard | | Floor life level | |
|-------------------|------------------------|----------------------|---------------------------|------------------------|----------------|-----|-----|-----------|---------------------------------------|-----------------------------|---------------------|-----------------------|-------------|---------------------------|--------------------|--------------------|
| | | | | | L | W | H | | Ripple ^{*1} current (mA rms) | ESR ^{*2} (mΩ max.) | tan δ ^{*3} | LC ^{*4} (μA) | Part number | Min. packaging q'ty (pcs) | Reflow temp ≤260°C | Reflow temp ≤250°C |
| 2.0 | 105 | 2.0 | 105 | 270 | 3.5 | 2.8 | 1.9 | B2S | 3200 | 6/500 kHz | 0.08 | 108.0 | 2TPSF270M6E | 2000 | 5 | 5 |
| | 105 | 2.0 | 105 | | 3.5 | 2.8 | 1.9 | | 2400 | 9/300 kHz | 0.08 | 108.0 | 2TPSF270M9G | 2000 | 3 | 3 |
| 2.5 | 105 | 2.5 | 105 | | 3.5 | 2.8 | 1.9 | | 3200 | 6/500 kHz | 0.08 | 135.0 | ETPSF270M6E | 2000 | | |

*1: Ripple current (100 kHz / +45 °C) *2: ESR (100 kHz / +20 °C) *3: tan δ (120 Hz / +20 °C) *4: After 5 minutes

◆ Please refer to each page in this catalog for "Reflow conditions", "Taping specifications" and "Floor life level".



Conductive Polymer Tantalum Solid Capacitors

Surface Mount Type

TPE series B size

Features

- Small size (L 3.5 × W 2.8 × H 1.9 mm)
- Low ESR (15 mΩ max.)
- RoHS compliance, Halogen free

Specifications

| | | |
|-----------------------------|--|---|
| Size code | B2 | |
| Category temp. range | -55 °C to +105 °C | |
| Rated voltage range | 2.0 V to 10 V | |
| Category voltage range | 1.8 V to 8 V | |
| Rated capacitance range | 47 μF to 470 μF | |
| Capacitance tolerance | ±20 % (120 Hz / +20 °C) | |
| Leakage current | Please see the attached characteristics list | |
| Dissipation factor(tan δ) | Please see the attached characteristics list | |
| Surge voltage (V) | Rated voltage × 1.15 | |
| Endurance | +105 °C 1000 h rated voltage applied | |
| | Rated temp, +85 °C Products : +85 °C 1000 h, rated voltage applied | |
| | Capacitance change | Within ±20 % of the initial value |
| | Dissipation factor(tan δ) | ≤ 1.5 times of the initial limit |
| Damp heat (Steady State) | Leakage current | Within the initial limit |
| | +60 °C, 90 % to 95 % RH, 500 h, No-applied voltage | |
| | Capacitance change | Within +50 %, -20 % of the initial value (2R5TPE220MAZB (MAPB, MAFB), 2R5TPE330MAZB, 2TPE470MAJGB (MAFB)) |
| | Dissipation factor(tan δ) | ≤ 1.5 times of the initial limit |
| | Leakage current | ≤ 3 times of the initial limit |

Marking

Rated capacitance code

Polarity marking (+)

Rated voltage code

Lot No.

| R. voltage code | | Unit : V | |
|-----------------|-----|----------|-----|
| d | 2.0 | g | 4.0 |
| e | 2.5 | j | 6.3 |
| | | k | 8.0 |
| | | A | 10 |

| R. capacitance code | | Unit : μF | |
|---------------------|-----|-----------|-----|
| S7 | 47 | E8 | 150 |
| A8 | 100 | J8 | 220 |
| C8 | 120 | N8 | 330 |
| | | S8 | 470 |

Dimensions (not to scale)

| Size code | L±0.2 | W±0.2 | H±0.1 | S±0.2 | W1±0.1 |
|-----------|-------|-------|-------|-------|--------|
| B2 | 3.5 | 2.8 | 1.9 | 0.8 | 2.2 |

Unit : mm

* Externals of figure are the reference.

Characteristics list

| Rated voltage (V) | Rated temperature (°C) | Category voltage (V) | Category temperature (°C) | Rated capacitance (μF) | Case size (mm) | | | Size code | Specifications | | | | Standard | | Floor life level | | |
|-------------------|------------------------|----------------------|---------------------------|------------------------|----------------|-----|------|-----------|-------------------------|-----------------|----------|-------------|---------------|---------------------------|--------------------|--------------------|------|
| | | | | | L | W | H | | Ripple current (mA rms) | ESR*2 (mΩ max.) | tan δ*3 | LC*4 (μA) | Part number | Min. packaging q'ty (pcs) | Reflow temp ≤260°C | Reflow temp ≤250°C | |
| 2.0 | 85 | 1.8 | 105 | 470 | 3.5 | 2.8 | 1.9 | B2 | 2300 | 15 | 0.10 | 188.0 | 2TPE470MAFB | 2000 | 3 | 3 | |
| | 85 | 1.8 | 105 | | 3.5 | 2.8 | 1.9 | | 2300 | 11/300kHz | 0.08 | 188.0 | 2TPE470MAJGB | 2000 | | | |
| 2.5 | 85 | 2.0 | 105 | 220 | 3.5 | 2.8 | 1.9 | | 2000 | 15 | 0.08 | 110.0 | 2R5TPE220MAFB | 2000 | | | |
| | 105 | 2.5 | 105 | | 3.5 | 2.8 | 1.9 | | 1800 | 15/300kHz | 0.08 | 110.0 | 2R5TPE220MFGB | 2000 | | | |
| | 105 | 2.5 | 105 | | 3.5 | 2.8 | 1.9 | | 1700 | 21 | 0.08 | 55.0 | 2R5TPE220MLB | 2000 | | | |
| | 85 | 2.0 | 105 | | 3.5 | 2.8 | 1.9 | | 1600 | 25 | 0.08 | 55.0 | 2R5TPE220MAPB | 2000 | | | |
| | 105 | 2.5 | 105 | | 3.5 | 2.8 | 1.9 | | 1400 | 35 | 0.08 | 55.0 | 2R5TPE220MZB | 2000 | | | |
| | 85 | 2.0 | 105 | | 3.5 | 2.8 | 1.9 | | 1400 | 35 | 0.08 | 55.0 | 2R5TPE220MAZB | 2000 | | | |
| | 105 | 2.5 | 105 | | 3.5 | 2.8 | 1.9 | | 1400 | 30 | 0.08 | 55.0 | 2R5TPE220MUB | 2000 | | | |
| | 85 | 2.0 | 105 | | 330 | 3.5 | 2.8 | | 1.9 | 1400 | 35 | 0.08 | 82.5 | 2R5TPE330MAZB | | | 2000 |
| | 85 | 2.0 | 105 | | | 3.5 | 2.8 | | 1.9 | 3200 | 9/300kHz | 0.08 | 165.0 | ETPE330MA9GB | | | 2000 |
| | 105 | 2.5 | 105 | | | 3.5 | 2.8 | | 1.9 | 3200 | 9/300kHz | 0.08 | 165.0 | ETPE330M9GB | | | 2000 |
| 105 | 2.5 | 105 | 3.5 | 2.8 | | 1.9 | 2700 | | 15 | 0.08 | 165.0 | ETPE330MFB | 2000 | | | | |
| 4.0 | 105 | 4.0 | 105 | 100 | 3.5 | 2.8 | 1.9 | | 2450 | 18 | 0.08 | 165.0 | ETPE330MIB | 2000 | | | |
| | 105 | 4.0 | 105 | | 3.5 | 2.8 | 1.9 | | 1400 | 35 | 0.08 | 40.0 | 4TPE100MZB | 2000 | | | |
| | 105 | 4.0 | 105 | | 3.5 | 2.8 | 1.9 | | 950 | 70 | 0.08 | 40.0 | 4TPE100MBB | 2000 | | | |
| | 85 | 3.2 | 105 | 150 | 3.5 | 2.8 | 1.9 | | 1300 | 40 | 0.08 | 40.0 | 4TPE100MWB | 2000 | | | |
| | 85 | 3.2 | 105 | 220 | 3.5 | 2.8 | 1.9 | | 1400 | 35 | 0.08 | 60.0 | 4TPE150MAZB | 2000 | | | |
| | NRFND | 105 | 4.0 | | 105 | 3.5 | 2.8 | | 1.9 | 1400 | 35 | 0.08 | 88.0 | 4TPE220MAZB | | | 2000 |
| | NRFND | 105 | 4.0 | | 105 | 3.5 | 2.8 | | 1.9 | 1350 | 35 | 0.10 | 88.0 | 4TPE220MZB | | | 2000 |
| | NRFND | 105 | 4.0 | | 105 | 3.5 | 2.8 | 1.9 | 1150 | 45 | 0.10 | 88.0 | 4TPE220MVB | 2000 | | | |
| | 6.3 | 105 | 6.3 | 105 | 100 | 3.5 | 2.8 | 1.9 | 950 | 70 | 0.10 | 88.0 | 4TPE220MBB | 2000 | | | |
| | | 85 | 5.0 | 105 | | 3.5 | 2.8 | 1.9 | 1600 | 25 | 0.08 | 63.0 | 6TPE100MPB | 2000 | | | |
| 105 | | 6.3 | 105 | 3.5 | | 2.8 | 1.9 | 1400 | 35 | 0.08 | 63.0 | 6TPE100MAZB | 2000 | | | | |
| 105 | | 6.3 | 105 | 3.5 | | 2.8 | 1.9 | 1400 | 35 | 0.08 | 63.0 | 6TPE100MZB | 2000 | | | | |
| 105 | | 6.3 | 105 | 3.5 | | 2.8 | 1.9 | 950 | 70 | 0.08 | 63.0 | 6TPE100MBB | 2000 | | | | |
| 105 | | 6.3 | 105 | 3.5 | | 2.8 | 1.9 | 1300 | 40 | 0.08 | 63.0 | 6TPE100MWB | 2000 | | | | |
| 105 | | 6.3 | 105 | 3.5 | | 2.8 | 1.9 | 1200 | 45 | 0.08 | 63.0 | 6TPE100MVB | 2000 | | | | |
| 85 | | 5.0 | 105 | 120 | 3.5 | 2.8 | 1.9 | 1400 | 35 | 0.08 | 75.6 | 6TPE120MAZB | 2000 | | | | |
| 85 | | 5.0 | 105 | 150 | 3.5 | 2.8 | 1.9 | 1600 | 25 | 0.08 | 94.5 | 6TPE150MAPB | 2000 | | | | |
| 85 | | 5.0 | 105 | | 3.5 | 2.8 | 1.9 | 1400 | 35 | 0.08 | 94.5 | 6TPE150MAZB | 2000 | | | | |
| 8.0 | | 85 | 5.0 | 105 | 220 | 3.5 | 2.8 | 1.9 | 1400 | 35 | 0.10 | 138.6 | 6TPE220MAZB | 2000 | | | |
| | | 85 | 5.0 | 105 | | 3.5 | 2.8 | 1.9 | 1600 | 25 | 0.10 | 138.6 | 6TPE220MAPB | 2000 | | | |
| | | NRFND | 105 | 6.3 | | 105 | 3.5 | 2.8 | 1.9 | 1150 | 45 | 0.10 | 138.6 | 6TPE220MVB | 2000 | | |
| | | NRFND | 105 | 6.3 | | 105 | 3.5 | 2.8 | 1.9 | 950 | 70 | 0.10 | 138.6 | 6TPE220MBB | 2000 | | |
| | NRFND | 105 | 6.3 | 105 | | 3.5 | 2.8 | 1.9 | 1350 | 35 | 0.10 | 138.6 | 6TPE220MZB | 2000 | | | |
| | 8.0 | 85 | 6.3 | 105 | | 100 | 3.5 | 2.8 | 1.9 | 1400 | 35 | 0.08 | 80.0 | 8TPE100MAZB | 2000 | | |
| 10 | 85 | 8.0 | 105 | 47 | 3.5 | 2.8 | 1.9 | 1400 | 35 | 0.08 | 47.0 | 10TPE47MAZB | 2000 | | | | |

*1: Ripple current (100 kHz / +45 °C)

NRFND Not recommended for new design

*2: ESR (100 kHz / +20 °C)

*3: tan δ (120 Hz / +20 °C)

*4: After 5 minutes

◆ Please refer to each page in this catalog for "Reflow conditions", "Taping specifications" and "Floor life level".

◆ Small order quantity (500 pcs/reel) is available with TPE series. Please contact our sales representative if you prefer it.

Conductive Polymer Tantalum
Solid Capacitors
Surface Mount Type
TPE series D size

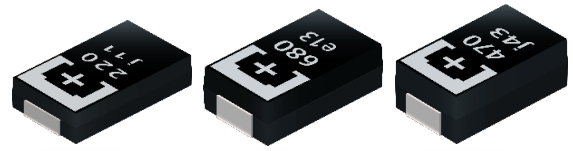

Features

- Low ESR (7 mΩ max.)
- Large capacitance (1500 μF max.)
- RoHS compliance, Halogen free

Specifications

| Size code | D2E | D3L | D4 |
|---------------------------|---|---|-------------------|
| Category temp. range | -55 °C to +105 °C | | |
| Rated voltage range | 2.5 V to 10 V | | |
| Category voltage range | 2.5 V to 10 V | | |
| Rated capacitance range | 68 μF to 470 μF | 150 μF to 680 μF | 330 μF to 1500 μF |
| Capacitance tolerance | ±20 % (120 Hz / +20 °C) | | |
| Leakage current | Please see the attached characteristics list | | |
| Dissipation factor(tan δ) | Please see the attached characteristics list | | |
| Surge voltage (V) | Rated voltage × 1.15 | | |
| Endurance | +105 °C 2000 h rated voltage applied Rated temp, +85 °C Products : +85 °C 1000 h, rated voltage applied (6TPE330MAP : +85 °C 2000 h, rated voltage applied) | | |
| | Capacitance change | Within ±20 % of the initial value | |
| | Dissipation factor(tan δ) | ≤ 1.5 times of the initial limit | |
| | Leakage current | Within the initial limit | |
| Damp heat (Steady State) | +60 °C, 90 % to 95 % RH, 500 h, No-applied voltage | | |
| | Capacitance change | Within +50 %, -20 % of the initial value (2R5TPE220M (I, F, 9), 2R5TPE330M (I, F, C, 9, 7), 2R5TPE470M (I, F, C, 9, 7), 2R5TPE1000MF, 2R5TPE1500M (F, C)) | |
| | Dissipation factor(tan δ) | ≤ 1.5 times of the initial limit | |
| | Leakage current | ≤ 3 times of the initial limit | |

Marking

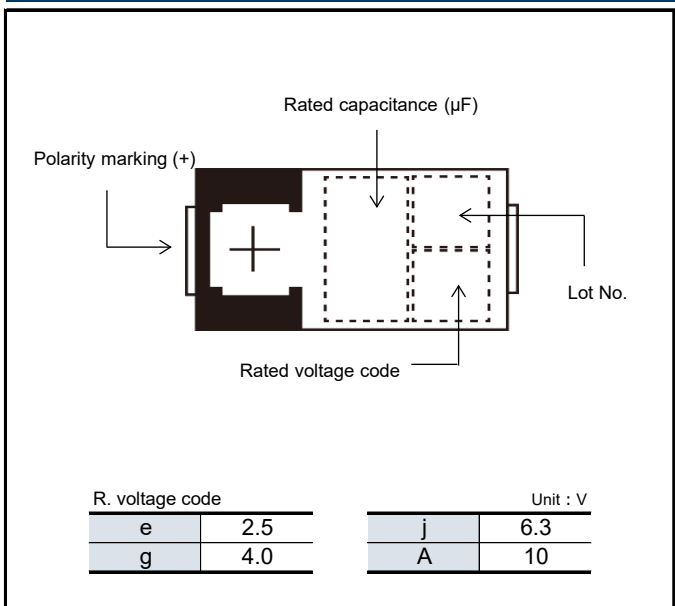

Dimensions (not to scale)

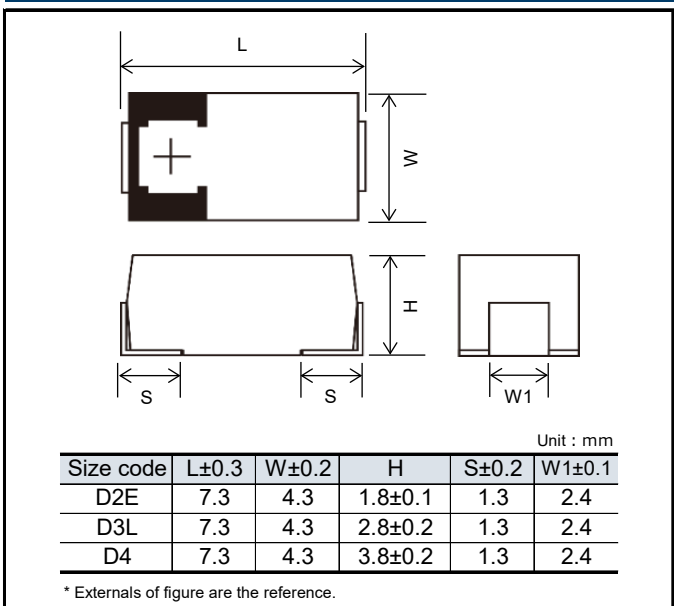

Characteristics list

| Rated voltage (V) | Rated temperature (°C) | Category voltage (V) | Category temperature (°C) | Rated capacitance (μF) | Case size (mm) | | | Size code | Specifications | | | | Standard | | Floor life level | | | | | | | | | | |
|-------------------|------------------------|----------------------|---------------------------|------------------------|----------------|-------|------------|-----------|---------------------------------------|-----------------------------|---------------------|-----------------------|-------------|---------------------------|--------------------|--------------------|------------|-------------|------------|------------|--------------|--------------|-----------|------------|------|
| | | | | | L | W | H | | Ripple ^{*1} current (mA rms) | ESR ^{*2} (mΩ max.) | tan δ ^{*3} | LC ^{*4} (μA) | Part number | Min. packaging q'ty (pcs) | Reflow temp ≤260°C | Reflow temp ≤250°C | | | | | | | | | |
| 2.5 | 105 | 2.5 | 105 | 220 | 7.3 | 4.3 | 1.8 | D2E | 3900 | 9 | 0.10 | 55.0 | 2R5TPE220M9 | 3000 | 3 | | | | | | | | | | |
| | | | | | 7.3 | 4.3 | 1.8 | | 3100 | 15 | 0.10 | 55.0 | 2R5TPE220MF | 3000 | | | | | | | | | | | |
| | 7.3 | 4.3 | 1.8 | | 2800 | 18 | 0.10 | | 55.0 | 2R5TPE220MI | 3000 | | | | | | | | | | | | | | |
| | NRFND | 105 | 2.5 | | 105 | 7.3 | 4.3 | | 1.8 | 2400 | 25 | 0.10 | 55.0 | 2R5TPE220M | | | 3000 | | | | | | | | |
| | 105 | 2.5 | 105 | | 7.3 | 4.3 | 1.8 | | 4400 | 7 | 0.10 | 82.5 | 2R5TPE330M7 | 3000 | | | | | | | | | | | |
| | 105 | 2.5 | 105 | | 7.3 | 4.3 | 1.8 | | 3900 | 9 | 0.10 | 82.5 | 2R5TPE330M9 | 3000 | | | | | | | | | | | |
| | NRFND | 105 | 2.5 | 105 | 330 | 7.3 | 4.3 | | 1.8 | 3500 | 12 | 0.10 | 82.5 | 2R5TPE330MC | | | 3000 | | | | | | | | |
| | | | | | | 7.3 | 4.3 | | 1.8 | 3100 | 15 | 0.10 | 82.5 | 2R5TPE330MF | | | 3000 | | | | | | | | |
| | | | | | | 7.3 | 4.3 | | 1.8 | 2800 | 18 | 0.10 | 82.5 | 2R5TPE330MI | | | 3000 | | | | | | | | |
| | | | | | | 7.3 | 4.3 | | 1.8 | 2400 | 25 | 0.10 | 82.5 | 2R5TPE330M | | | 3000 | | | | | | | | |
| | | | | | | 7.3 | 4.3 | | 1.8 | 4400 | 7 | 0.10 | 117.5 | 2R5TPE470M7 | | | 3000 | | | | | | | | |
| | | | | | | 7.3 | 4.3 | | 1.8 | 3900 | 9 | 0.10 | 117.5 | 2R5TPE470M9 | | | 3000 | | | | | | | | |
| | | | | | 470 | 105 | 2.5 | | 105 | 470 | 7.3 | 4.3 | 1.8 | 3500 | 12 | 0.10 | 117.5 | 2R5TPE470MC | 3000 | | | | | | |
| | | | | | | | | | | | 7.3 | 4.3 | 1.8 | 3100 | 15 | 0.10 | 117.5 | 2R5TPE470MF | 3000 | | | | | | |
| | | | | | | | | | | | 7.3 | 4.3 | 1.8 | 2800 | 18 | 0.10 | 117.5 | 2R5TPE470MI | 3000 | | | | | | |
| | | | | | | | | | | | 7.3 | 4.3 | 1.8 | 2400 | 25 | 0.10 | 117.5 | 2R5TPE470M | 3000 | | | | | | |
| | | | | | | | | | | 680 | 105 | 2.5 | 105 | 680 | 7.3 | 4.3 | 2.8 | 3500 | 12 | 0.10 | 170.0 | 2R5TPE680MCL | 2500 | | |
| | | | | | | | | | | | | | | | 7.3 | 4.3 | 2.8 | 3100 | 15 | 0.10 | 170.0 | 2R5TPE680MFL | 2500 | | |
| | | | | | | | | | | | | | | 7.3 | 4.3 | 2.8 | 1850 | 40 | 0.10 | 170.0 | 2R5TPE680MWL | 2500 | | | |
| | | | | | | | | | | | | | | 7.3 | 4.3 | 3.8 | 3900 | 15 | 0.15 | 250.0 | 2R5TPE1000MF | 2000 | | | |
| 1500 | 105 | 2.5 | 105 | 1500 | 7.3 | 4.3 | 3.8 | 4400 | 12 | 0.15 | 375.0 | 2R5TPE1500MC | 2000 | | | | | | | | | | | | |
| | | | | | 7.3 | 4.3 | 3.8 | 3900 | 15 | 0.15 | 375.0 | 2R5TPE1500MF | 2000 | | | | | | | | | | | | |
| 4.0 | 105 | 4.0 | 105 | 150 | 7.3 | 4.3 | 1.8 | D2E | 2800 | 18 | 0.10 | 60.0 | 4TPE150MI | 3000 | 2a | | | | | | | | | | |
| | | | | | 7.3 | 4.3 | 1.8 | | 3100 | 15 | 0.10 | 88.0 | 4TPE220MF | 3000 | | | | | | | | | | | |
| | | | | | 7.3 | 4.3 | 1.8 | | 2800 | 18 | 0.10 | 88.0 | 4TPE220MI | 3000 | | | | | | | | | | | |
| | | | | | 7.3 | 4.3 | 1.8 | | 2400 | 25 | 0.10 | 88.0 | 4TPE220M | 3000 | | | | | | | | | | | |
| | | | | | 7.3 | 4.3 | 1.8 | | 1750 | 45 | 0.10 | 88.0 | 4TPE220MV | 3000 | | | | | | | | | | | |
| | | | | | 7.3 | 4.3 | 1.8 | | 2800 | 18 | 0.10 | 132.0 | 4TPE330MI | 3000 | | | | | | | | | | | |
| | | | | 330 | 105 | 4.0 | 105 | | 330 | 7.3 | 4.3 | 1.8 | 2400 | 25 | | | 0.10 | 132.0 | 4TPE330M | 3000 | | | | | |
| | | | | | | | | | | 7.3 | 4.3 | 1.8 | 1850 | 40 | | | 0.10 | 132.0 | 4TPE330MW | 3000 | | | | | |
| | | | | | | | | | | 7.3 | 4.3 | 2.8 | 3500 | 12 | | | 0.10 | 188.0 | 4TPE470MCL | 2500 | | | | | |
| | | | | | | | | | | 7.3 | 4.3 | 2.8 | 3100 | 15 | | | 0.10 | 188.0 | 4TPE470MFL | 2500 | | | | | |
| | | | | | | | | | 470 | 105 | 4.0 | 105 | 470 | 7.3 | | | 4.3 | 2.8 | D3L | 2800 | 18 | 0.10 | 188.0 | 4TPE470MIL | 2500 |
| | | | | | | | | | | | | | | 7.3 | | | 4.3 | 2.8 | 2400 | 25 | 0.10 | 188.0 | 4TPE470ML | 2500 | |
| | | | | | | | | | | | | | 7.3 | 4.3 | 2.8 | 1850 | 40 | 0.10 | 188.0 | 4TPE470MWL | 2500 | | | | |
| | | | | | | | | | | | | | 7.3 | 4.3 | 2.8 | 2800 | 18 | 0.10 | 188.0 | 4TPE470MFL | 2500 | | | | |
| | | | | 6.3 | 105 | 6.3 | 105 | | 100 | 7.3 | 4.3 | 1.8 | D2E | 2800 | 18 | 0.10 | 63.0 | 6TPE100MI | 3000 | 3 | | | | | |
| | | | | | | | | | | 7.3 | 4.3 | 1.8 | | 2400 | 25 | 0.10 | 63.0 | 6TPE100M | 3000 | | | | | | |
| | | | | | | | | | | 7.3 | 4.3 | 1.8 | | 1850 | 40 | 0.10 | 63.0 | 6TPE100MW | 3000 | | | | | | |
| | | | | | | | | | | 7.3 | 4.3 | 1.8 | | 3100 | 15 | 0.10 | 94.5 | 6TPE150MF | 3000 | | | | | | |
| | | | | | | | | | | 7.3 | 4.3 | 1.8 | | 2800 | 18 | 0.10 | 94.5 | 6TPE150MI | 3000 | | | | | | |
| | | | | | | | | | | 7.3 | 4.3 | 1.8 | | 2400 | 25 | 0.10 | 94.5 | 6TPE150M | 3000 | | | | | | |
| 150 | 105 | 6.3 | 105 | | | | | 150 | 7.3 | 4.3 | 1.8 | 2800 | | 18 | 0.10 | 138.6 | 6TPE220MI | 3000 | | | | | | | |
| | | | | | | | | | 7.3 | 4.3 | 1.8 | 2400 | | 25 | 0.10 | 138.6 | 6TPE220M | 3000 | | | | | | | |
| | | | | | | | | | 7.3 | 4.3 | 1.8 | 2400 | | 25 | 0.10 | 138.6 | 6TPE220MAP | 3000 | | | | | | | |
| | | | | | | | | | 7.3 | 4.3 | 1.8 | 1850 | | 40 | 0.10 | 138.6 | 6TPE220MW | 3000 | | | | | | | |
| | | | | | | | | 220 | 105 | 6.3 | 105 | 220 | | 7.3 | 4.3 | 1.8 | D3L | 2800 | 18 | | | 0.10 | 138.6 | 6TPE220MIL | 2500 |
| | | | | | | | | | | | | | | 7.3 | 4.3 | 2.8 | D2E | 2400 | 25 | | | 0.10 | 207.9 | 6TPE330MAP | 3000 |
| | | | | | | | | NRFND | 85 | 5.0 | 105 | 330 | | 7.3 | 4.3 | 2.8 | D3L | 3900 | 9/500kHz | 0.10 | 207.9 | 6TPE330MA9EL | 2500 | | |
| | | | | | | | | | | | | | | 7.3 | 4.3 | 2.8 | | 3100 | 15 | 0.10 | 207.9 | 6TPE330MFL | 2500 | | |
| 7.3 | 4.3 | 2.8 | 2800 | 18 | 0.10 | 207.9 | 6TPE330MIL | | | | | | 2500 | | | | | | | | | | | | |
| 7.3 | 4.3 | 2.8 | 2400 | 25 | 0.10 | 207.9 | 6TPE330ML | | | | | | 2500 | | | | | | | | | | | | |
| 7.3 | 4.3 | 3.8 | D4 | 4400 | 10 | 0.10 | 207.9 | | | | | | 6TPE330MAA | 2000 | | | | | | | | | | | |
| 7.3 | 4.3 | 3.8 | 3500 | 18 | 0.15 | 296.1 | 6TPE470MI | | | | | | 2000 | | | | | | | | | | | | |
| 470 | 105 | 6.3 | 105 | 470 | 7.3 | 4.3 | 3.8 | | | | | D4 | 3000 | 25 | 0.15 | 296.1 | | 6TPE470M | 2000 | | | | | | |
| | | | | | 7.3 | 4.3 | 3.8 | | | | | | 2500 | 35 | 0.15 | 296.1 | | 6TPE470MZ | 2000 | | | | | | |
| | | | | 7.3 | 4.3 | 3.8 | 2350 | | | | | | 40 | 0.15 | 296.1 | 6TPE470MW | | 2000 | | | | | | | |
| | | | | 7.3 | 4.3 | 3.8 | 3500 | | | | | | 18 | 0.15 | 428.4 | 6TPE680MI | | 2000 | | | | | | | |
| 680 | 105 | 6.3 | 105 | 680 | 7.3 | 4.3 | 3.8 | 3000 | 25 | 0.15 | 428.4 | 6TPE680M | 2000 | | | | | | | | | | | | |
| | | | | | 7.3 | 4.3 | 3.8 | D2E | 2400 | 25 | 0.10 | 68.0 | 10TPE68M | 3000 | | | | | | | | | | | |
| NRFND | 105 | 10 | 105 | 68 | 7.3 | 4.3 | 1.8 | D2E | 1850 | 40 | 0.10 | 68.0 | 10TPE68MW | 3000 | | | | | | | | | | | |
| | | | | | 7.3 | 4.3 | 1.8 | | 2400 | 25 | 0.10 | 150.0 | 10TPE150MPL | 2500 | | | | | | | | | | | |
| | | | | 150 | 105 | 10 | 105 | | 150 | 7.3 | 4.3 | 2.8 | D3L | 2800 | 18 | 0.10 | 220.0 | 10TPE220MIL | 2500 | | | | | | |
| | | | | | | | | | | 7.3 | 4.3 | 2.8 | | 2400 | 25 | 0.10 | 220.0 | 10TPE220ML | 2500 | | | | | | |
| | | | | | | | | | 220 | 105 | 10 | 105 | | 220 | 7.3 | 4.3 | 2.8 | 3000 | 25 | 0.10 | 330.0 | 10TPE330M | 2000 | | |
| | | | | | | | | | | | | | | | 7.3 | 4.3 | 2.8 | D4 | 3000 | 25 | 0.10 | 330.0 | 10TPE330M | 2000 | |

*1: Ripple current (100 kHz / +45 °C) *2: ESR (100 kHz / +20 °C) *3: tan δ (120 Hz / +20 °C) *4: After 5 minutes

◆ Please refer to each page in this catalog for "Reflow conditions", "Taping specifications" and "Floor life level".

◆ Small order quantity (500 pcs/reel) is available with TPE series. Please contact our sales representative if you prefer it.

NRFND Not recommended for new design

Conductive Polymer Tantalum Solid Capacitors Surface Mount Type TPF series

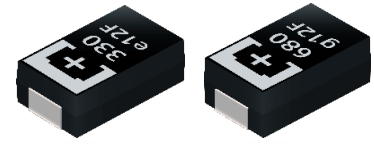

Features

- Super low ESR (5 mΩ max.)
- Large capacitance (1000 μF max.)
- RoHS compliance, Halogen free

Specifications

| Size code | D3L | D4 |
|---------------------------|--|--|
| Category temp. range | -55 °C to +105 °C | |
| Rated voltage range | 2.5 V to 10 V | 2.5 V to 6.3 V |
| Category voltage range | 2.5 V to 10 V | 2.5 V to 6.3 V |
| Rated capacitance range | 150 μF to 680 μF | 470 μF to 1000 μF |
| Capacitance tolerance | ±20 % (120 Hz / +20 °C) | |
| Leakage current | Please see the attached characteristics list | |
| Dissipation factor(tan δ) | Please see the attached characteristics list | |
| Surge voltage (V) | Rated voltage × 1.15 | |
| Endurance | +105 °C 2000 h rated voltage applied | |
| | Capacitance change | Within ±20 % of the initial value |
| | Dissipation factor(tan δ) | ≤ 1.5 times of the initial limit |
| | Leakage current | Within the initial limit |
| Damp heat (Steady State) | +60 °C, 90 % to 95 % RH, 500 h, No-applied voltage | |
| | Capacitance change | Within +50 %, -20 % of the initial value (2TPF220M6, 2TPF330M6, ETPF1000M6H (5H)) |
| | Dissipation factor(tan δ) | ≤ 1.5 times of the initial limit (Except for above model) |
| | Leakage current | ≤ 3 times of the initial limit |

Marking

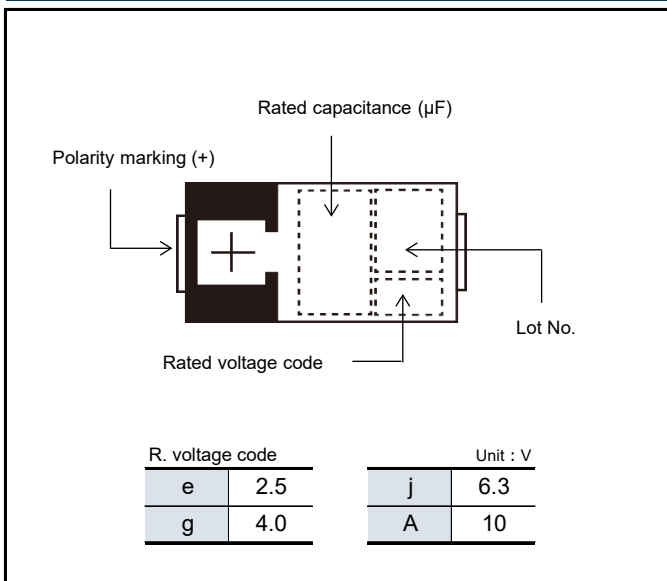

Dimensions (not to scale)

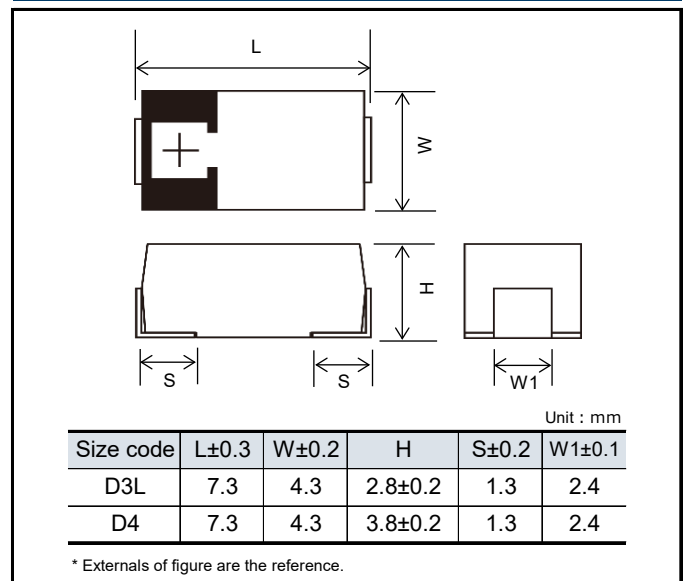

Characteristics list

| Rated voltage (V) | Rated temperature (°C) | Category voltage (V) | Category temperature (°C) | Rated capacitance (µF) | Case size (mm) | | | Size code | Specifications | | | | Standard | | Floor life level | | |
|-------------------|------------------------|----------------------|---------------------------|------------------------|----------------|-----|-----|-----------|-------------------------|-----------------------------|---------------------|-----------------------|--------------|--------------------------|--------------------|--------------------|------|
| | | | | | L | W | H | | Ripple current (mA rms) | ESR* ² (mΩ max.) | tan δ* ³ | LC* ⁴ (µA) | Part number | Min. packaging qty (pcs) | Reflow temp ≤260°C | Reflow temp ≤250°C | |
| 2.5 | 105 | 2.5 | 105 | 470 | 7.3 | 4.3 | 2.8 | D3L | 4400 | 6 | 0.10 | 117.5 | 2R5TPF470M6L | 2500 | 3 | 2a | |
| | 105 | 2.5 | 105 | | 7.3 | 4.3 | 2.8 | | 4400 | 7 | 0.10 | 117.5 | 2R5TPF470M7L | 2500 | | | |
| | 105 | 2.5 | 105 | | 7.3 | 4.3 | 2.8 | | 4400 | 10 | 0.10 | 117.5 | 2R5TPF470ML | 2500 | | | |
| | NRFND 105 | 2.5 | 105 | | 7.3 | 4.3 | 3.8 | D4 | 6100 | 5 | 0.10 | 117.5 | ETPF470M5H | 2000 | | | |
| | 105 | 2.5 | 105 | 680 | 7.3 | 4.3 | 2.8 | D3L | 3850 | 9 | 0.10 | 117.5 | 2R5TPF470M9L | 2500 | | | |
| | 105 | 2.5 | 105 | | 7.3 | 4.3 | 2.8 | | 4400 | 6 | 0.10 | 170.0 | 2R5TPF680M6L | 2500 | | | |
| | 105 | 2.5 | 105 | | 7.3 | 4.3 | 2.8 | | 4400 | 7 | 0.10 | 170.0 | 2R5TPF680M7L | 2500 | | | |
| | NRFND 105 | 2.5 | 105 | | 7.3 | 4.3 | 2.8 | 4400 | 10 | 0.10 | 170.0 | 2R5TPF680ML | 2500 | | | | |
| | 105 | 2.5 | 105 | 1000 | 7.3 | 4.3 | 3.8 | D4 | 6100 | 5 | 0.10 | 170.0 | ETPF680M5H | 2000 | | | |
| | 105 | 2.5 | 105 | | 7.3 | 4.3 | 3.8 | | 2700 | 25 | 0.10 | 170.0 | ETPF680MPH | 2000 | | | |
| | 105 | 2.5 | 105 | | 7.3 | 4.3 | 3.8 | | 6100 | 5 | 0.10 | 250.0 | ETPF1000M5H | 2000 | | | |
| | 105 | 2.5 | 105 | | 7.3 | 4.3 | 3.8 | 5600 | 6 | 0.10 | 250.0 | ETPF1000M6H | 2000 | | | | |
| 4.0 | 105 | 4.0 | 105 | 330 | 7.3 | 4.3 | 2.8 | D3L | 3900 | 9 | 0.10 | 132.0 | 4TPF330M9L | 2500 | | | |
| | 105 | 4.0 | 105 | | 7.3 | 4.3 | 2.8 | | 4000 | 12 | 0.10 | 132.0 | 4TPF330ML | 2500 | | | |
| | 105 | 4.0 | 105 | | 7.3 | 4.3 | 2.8 | | 3550 | 15 | 0.10 | 132.0 | 4TPF330MFL | 2500 | | | |
| | 105 | 4.0 | 105 | 680 | 7.3 | 4.3 | 2.8 | D4 | 4400 | 10 | 0.10 | 188.0 | 4TPF470ML | 2500 | | | |
| | 105 | 4.0 | 105 | | 7.3 | 4.3 | 3.8 | | 4400 | 10 | 0.10 | 272.0 | 4TPF680MAH | 2000 | | | |
| | 105 | 4.0 | 105 | | 7.3 | 4.3 | 3.8 | | 3550 | 15 | 0.10 | 272.0 | 4TPF680MFH | 2000 | | | |
| 6.3 | 105 | 6.3 | 105 | 150 | 7.3 | 4.3 | 2.8 | D3L | 2750 | 25 | 0.10 | 94.5 | 6TPF150MPL | 2500 | 3 | - | |
| | NRFND 105 | 6.3 | 105 | | 7.3 | 4.3 | 2.8 | | 5550 | 6 | 0.10 | 138.6 | 6TPF220M6L | 2500 | | | |
| | NRFND 105 | 6.3 | 105 | 220 | 7.3 | 4.3 | 2.8 | | 4600 | 9 | 0.10 | 138.6 | 6TPF220M9L | 2500 | | | |
| | 105 | 6.3 | 105 | | 7.3 | 4.3 | 2.8 | | 4000 | 12 | 0.10 | 138.6 | 6TPF220ML | 2500 | | | |
| | 105 | 6.3 | 105 | | 7.3 | 4.3 | 2.8 | | 3550 | 15 | 0.10 | 138.6 | 6TPF220MFL | 2500 | | | |
| | 105 | 6.3 | 105 | | 7.3 | 4.3 | 2.8 | | 2750 | 25 | 0.10 | 138.6 | 6TPF220MPL | 2500 | | | |
| | 105 | 6.3 | 105 | 330 | 7.3 | 4.3 | 2.8 | | 3900 | 9 | 0.10 | 207.9 | 6TPF330M9L | 2500 | | | |
| | 105 | 6.3 | 105 | | 7.3 | 4.3 | 2.8 | | 3650 | 10 | 0.10 | 207.9 | 6TPF330MAL | 2500 | | | |
| | 105 | 6.3 | 105 | 470 | 7.3 | 4.3 | 3.8 | | D4 | 4400 | 10 | 0.10 | 296.1 | 6TPF470MAH | | | 2000 |
| | 105 | 6.3 | 105 | | 7.3 | 4.3 | 3.8 | | | 3550 | 15 | 0.10 | 296.1 | 6TPF470MFH | | | 2000 |
| 10 | 105 | 10 | 105 | 150 | 7.3 | 4.3 | 2.8 | D3L | 3600 | 15 | 0.10 | 150.0 | 10TPF150ML | 2500 | - | - | |

*1: Ripple current (100 kHz / +45 °C)

NRFND

Not recommended for new design

*2: ESR (100 kHz / +20 °C)

*3: tan δ (120 Hz / +20 °C)

*4: After 5 minutes

- ◆ Please refer to each page in this catalog for "Reflow conditions", "Taping specifications" and "Floor life level".
- ◆ Small order quantity (500 pcs/reel) is available with TPF series. Please contact our sales representative if you prefer it.

**Conductive Polymer Tantalum
Solid Capacitors**
Surface Mount Type
TQT series

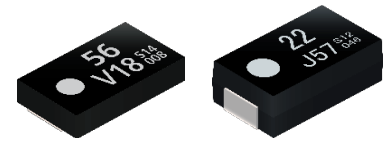

Features

- High voltage (35 V max.)
- Large capacitance
- RoHS compliance, Halogen free

Specifications

| | | |
|---------------------------|--|--|
| Size code | D15S | |
| Category temp. range | -55 °C ~ +105 °C | |
| Rated volt. range | 35 V | |
| Category volt. range | 35 V | |
| Rated cap. range | 56 μF | |
| Capacitance tolerance | ±20 % (120 Hz / +20 °C) | |
| Leakage current | Please see the attached characteristics list | |
| Dissipation factor(tan δ) | Please see the attached characteristics list | |
| Surge voltage (V) | Rated voltage × 1.15 | |
| Endurance | +105 °C 2000 h rated voltage applied | |
| | Capacitance change | Within ±20 % of the initial value |
| | Dissipation factor(tan δ) | ≤ 1.5 times of the initial limit |
| | Leakage current | Within the initial limit |
| Damp heat (Steady State) | +60 °C, 90 % to 95 % RH, 500 h, No-applied voltage | |
| | Capacitance change | Within +40 %, -20 % of the initial value |
| | Dissipation factor(tan δ) | ≤ 1.5 times of the initial limit |
| | Leakage current | ≤ 3 times of the initial limit |

Marking

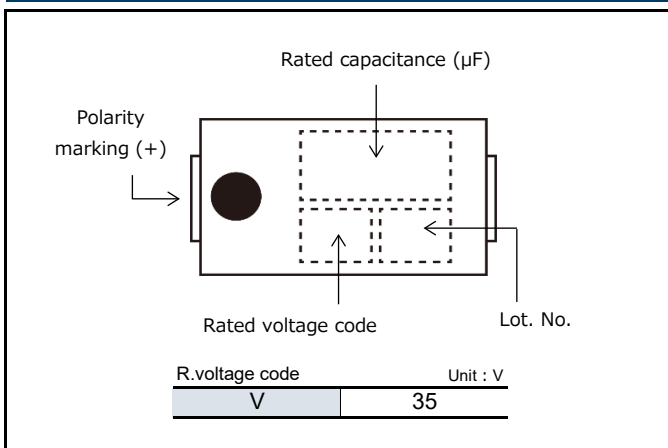

Dimensions (not to scale)

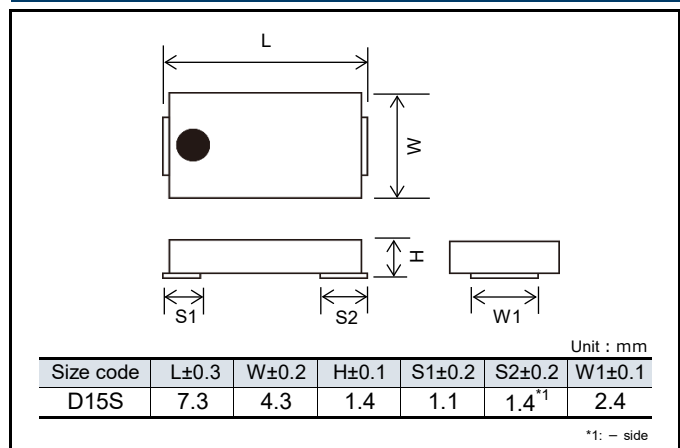

Characteristics list

| Rated voltage (V) | Rated temperature (°C) | Category voltage (V) | Category temperature (°C) | Rated capacitance (μF) | Case size (mm) | | | Size code | Specifications | | | | Standard | | Floor life level | Re-flow soldering |
|-------------------|------------------------|----------------------|---------------------------|------------------------|----------------|-----|-----|-----------|---------------------------------------|-----------------------------|---------------------|-----------------------|-------------|--------------------------|------------------|-------------------|
| | | | | | L | W | H | | Ripple current ^{*1} (mA rms) | ESR ^{*2} (mΩ max.) | tan δ ^{*3} | LC ^{*4} (μA) | Part number | Min. packaging qty (pcs) | | |
| 35 | 105 | 35 | 105 | 56 | 7.3 | 4.3 | 1.4 | D15S | 1200 | 100 | 0.10 | 196 | 35TQT56M | 4000 | 3 | A |

*1: Ripple current (100 kHz / +105 °C)

*2: ESR (100 kHz / +20 °C)

*3: tan δ (120 Hz / +20 °C)

*4: After 5 minutes

◆ Please refer to each page in this catalog for "Reflow conditions", "Taping specifications" and "Floor life level".

Conductive Polymer Tantalum Solid Capacitors Surface Mount Type TQS series

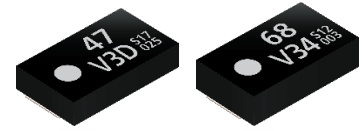

Features

- High voltage (35 V max.)
- RoHS compliance, Halogen free

Specifications

| Size code | D15S | D2S |
|---------------------------|--|--|
| Category temp. range | -55 °C to +105 °C | |
| Rated voltage range | 35 V | |
| Category voltage range | 35 V | |
| Rated capacitance range | 47 μF | 68 μF |
| Capacitance tolerance | ±20 % (120 Hz / +20 °C) | |
| Leakage current | Please see the attached characteristics list | |
| Dissipation factor(tan δ) | Please see the attached characteristics list | |
| Surge voltage (V) | Rated voltage × 1.15 | |
| Endurance | +105 °C 2000 h rated voltage applied | |
| | Capacitance change | Within ±20 % of the initial value |
| | Dissipation factor(tan δ) | ≤ 1.5 times of the initial limit |
| Damp heat (Steady State) | +60 °C, 90 % to 95 % RH, 500 h, No-applied voltage | |
| | Capacitance change | Within +40 %, -20 % of the initial value |
| | Dissipation factor(tan δ) | ≤ 1.5 times of the initial limit |
| | Leakage current | ≤ 3 times of the initial limit |

Marking

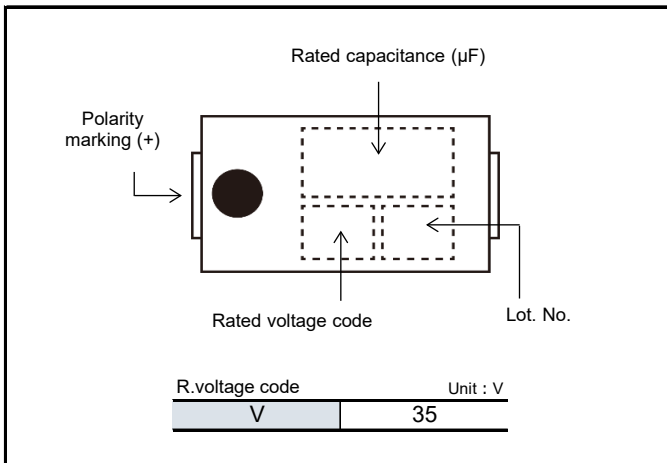

Dimensions (not to scale)

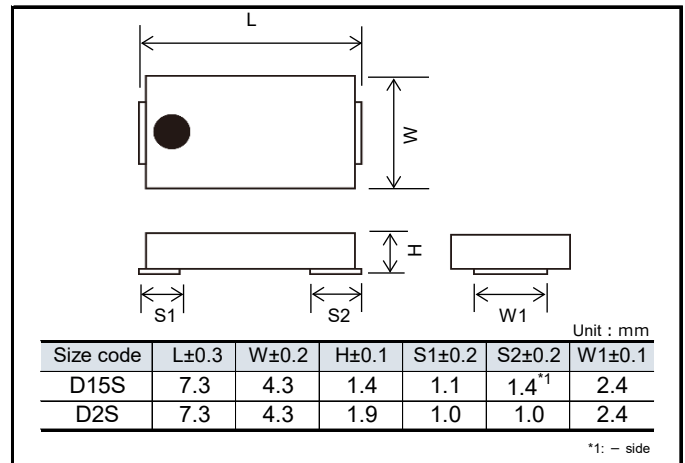

Characteristics list

| Rated voltage (V) | Rated temperature (°C) | Category voltage (V) | Category temperature (°C) | Rated capacitance (μF) | Case size (mm) | | | Size code | Specifications | | | | Standard | | Floor life level | Re-flow soldering |
|-------------------|------------------------|----------------------|---------------------------|------------------------|----------------|-----|-----|-----------|---------------------------------------|-----------------------------|---------------------|-----------------------|-------------|---------------------------|------------------|-------------------|
| | | | | | L | W | H | | Ripple ^{*1} current (mA rms) | ESR ^{*2} (mΩ max.) | tan δ ^{*3} | LC ^{*4} (μA) | Part number | Min. packaging q'ty (pcs) | | |
| 35 | 105 | 35 | 105 | 47 | 7.3 | 4.3 | 1.4 | D15S | 1200 | 100 | 0.10 | 164.5 | 35TQS47MEU | 4000 | 3 | A |
| | | | | 47 | 7.3 | 4.3 | 1.4 | D15S | 1200 | 100 | 0.10 | 164.5 | 35TQS47MEX | 4000 | | |
| | | | | 68 | 7.3 | 4.3 | 1.9 | D2S | 1200 | 100 | 0.10 | 238 | 35TQS68ME2 | 3000 | | |

^{*1}: Ripple current (100 kHz / +105 °C) ^{*2}: ESR (100 kHz / +20 °C) ^{*3}: tan δ (120 Hz / +20 °C) ^{*4}: After 5 minutes

◆ Please refer to each page in this catalog for "Reflow conditions", "Taping specifications" and "Floor life level". NRFND Not recommended for new design

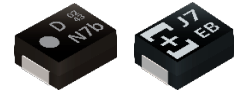

Conductive Polymer Tantalum Solid Capacitors

Surface Mount Type

TQC series B size

Features

- High voltage (35 V max.)
- RoHS compliance, Halogen free

Specifications

| | | |
|-----------------------------|--|--|
| Size code | B2 | |
| Category temp. range | -55 °C to +105 °C | |
| Rated voltage range | 16 V to 35 V | |
| Category voltage range | 16 V to 35 V | |
| Rated capacitance range | 10 μF to 47 μF | |
| Capacitance tolerance | ±20 % (120 Hz / +20 °C) | |
| Leakage current | Please see the attached characteristics list | |
| Dissipation factor(tan δ) | Please see the attached characteristics list | |
| Surge voltage (V) | Rated voltage × 1.15 | |
| Endurance | +105 °C 2000 h (16TQC33MYFB : 1000 h), rated voltage applied | |
| | Capacitance change | Within ±20 % of the initial value |
| | Dissipation factor(tan δ) | ≤ 1.5 times of the initial limit |
| | Leakage current | Within the initial limit |
| Damp heat (Steady State) | +60 °C, 90 % to 95 % RH, 500 h, No-applied voltage | |
| | Capacitance change | Within +40 %, -20 % of the initial value |
| | Dissipation factor(tan δ) | ≤ 1.5 times of the initial limit |
| | Leakage current | ≤ 3 times of the initial limit |

Marking

< Laser marking >

< Other than the above >

| | | | |
|---|----|---|----|
| C | 16 | E | 25 |
| D | 20 | V | 35 |

Unit : V

| | | | | | |
|----|----|----|----|----|----|
| A7 | 10 | J7 | 22 | S7 | 47 |
| E7 | 15 | N7 | 33 | | |

Unit : μF

Dimensions (not to scale)

| Size code | L±0.2 | W±0.2 | H±0.1 | S±0.2 | W1±0.1 |
|-----------|-------|-------|-------|-------|--------|
| B2 | 3.5 | 2.8 | 1.9 | 0.8 | 2.2 |

Unit : mm

* Externals of figure are the reference.

Characteristics list

| Rated voltage (V) | Rated temperature (°C) | Category voltage (V) | Category temperature (°C) | Rated capacitance (μF) | Case size (mm) | | | Size code | Specifications | | | | Standard | | Floor life level | Re-flow soldering |
|-------------------|------------------------|----------------------|---------------------------|------------------------|----------------|-----|-----|-----------|-------------------------|-----------------------------|---------------------|-----------------------|-------------|---------------------------|------------------|-------------------|
| | | | | | L | W | H | | Ripple current (mA rms) | ESR ^{*2} (mΩ max.) | tan δ ^{*3} | LC ^{*4} (μA) | Part number | Min. packaging q'ty (pcs) | | |
| 16 | NRFND 105 | 16 | 105 | 15 | 3.5 | 2.8 | 1.9 | B2 | 1000 | 90 | 0.10 | 72.0 | 16TQC15M | 2000 | 3 | D |
| | NRFND 105 | 16 | 105 | 22 | 3.5 | 2.8 | 1.9 | | 1000 | 90 | 0.10 | 35.2 | 16TQC22MYFB | 2000 | | |
| | NRFND 105 | 16 | 105 | 33 | 3.5 | 2.8 | 1.9 | | 1000 | 90 | 0.10 | 158.4 | 16TQC33MYFB | 2000 | | |
| | 105 | 16 | 105 | | 3.5 | 2.8 | 1.9 | | 1000 | 90 | 0.10 | 158.4 | 16TQC33MB2 | 2000 | | |
| | 105 | 16 | 105 | 47 | 3.5 | 2.8 | 1.9 | | 1000 | 90 | 0.15 | 225.6 | 16TQC47MYFB | 2000 | | |
| 20 | NRFND 105 | 20 | 105 | 22 | 3.5 | 2.8 | 1.9 | | 1000 | 90 | 0.10 | 132.0 | 20TQC22MYFB | 2000 | | D |
| | 105 | 20 | 105 | | 3.5 | 2.8 | 1.9 | | 1000 | 90 | 0.10 | 132.0 | 20TQC22MB2 | 2000 | | |
| | 105 | 20 | 105 | 33 | 3.5 | 2.8 | 1.9 | | 900 | 100 | 0.10 | 198.0 | 20TQC33MYFB | 2000 | | |
| 25 | NRFND 105 | 25 | 105 | 10 | 3.5 | 2.8 | 1.9 | | 900 | 100 | 0.10 | 25.0 | 25TQC10MEB | 2000 | D | |
| | NRFND 105 | 25 | 105 | 15 | 3.5 | 2.8 | 1.9 | | 900 | 100 | 0.10 | 112.5 | 25TQC15MYFB | 2000 | | |
| | 105 | 25 | 105 | | 3.5 | 2.8 | 1.9 | | 900 | 100 | 0.10 | 112.5 | 25TQC15MB | 2000 | | |
| | 105 | 25 | 105 | 22 | 3.5 | 2.8 | 1.9 | | 1100 | 100 | 0.10 | 165.0 | 25TQC22MYFB | 2000 | | |
| 35 | 105 | 35 | 105 | 10 | 3.5 | 2.8 | 1.9 | 900 | 150 | 0.15 | 105.0 | 35TQC10MYFB | 2000 | A | | |
| | 105 | 35 | 105 | | 3.5 | 2.8 | 1.9 | 750 | 200 | 0.15 | 105.5 | 35TQC10MXB | 2000 | | | |

*1: Ripple current (100 kHz / +105 °C)

*2: ESR (100 kHz / +20 °C)

*3: tan δ (120 Hz / +20 °C)

*4: After 5 minutes

NRFND Not recommended for new design

◆ Please refer to each page in this catalog for "Reflow conditions", "Taping specifications" and "Floor life level".

◆ Small order quantity (500 pcs/reel) is available with TQC series. Please contact our sales representative if you prefer it.



Some part numbers are not a recommended product.
Not recommended for new design.

Conductive Polymer Tantalum Solid Capacitors

Surface Mount Type

TQC series D size



Features

- High voltage (35 V max.)
- RoHS compliance, Halogen free

Specifications

| Size code | D15 | D2 | D3L |
|-----------------------------|--|--|-----------------|
| Category temp. range | -55 °C to +105 °C | | |
| Rated voltage range | 16 V to 25 V | 16 V to 35 V | 16 V to 25 V |
| Category voltage range | 16 V to 25 V | 16 V to 35 V | 16 V to 25 V |
| Rated capacitance range | 22 µF to 47 µF | 10 µF to 150 µF | 68 µF to 220 µF |
| Capacitance tolerance | ±20 % (120 Hz / +20 °C) | | |
| Leakage current | Please see the attached characteristics list | | |
| Dissipation factor(tan δ) | Please see the attached characteristics list | | |
| Surge voltage (V) | Rated voltage × 1.15 | | |
| Endurance | +105 °C 2000 h rated voltage applied | | |
| | Capacitance change | Within ±20 % of the initial value | |
| | Dissipation factor(tan δ) | ≤ 1.5 times of the initial limit | |
| | Leakage current | Within the initial limit | |
| Damp heat (Steady State) | +60 °C, 90 % to 95 % RH, 500 h, No-applied voltage | | |
| | Capacitance change | Within +40 %, -20 % of the initial value | |
| | Dissipation factor(tan δ) | ≤ 1.5 times of the initial limit | |
| | Leakage current | ≤ 3 times of the initial limit | |

Marking

Diagram illustrating the marking on the capacitor surface. The marking includes:

- Rated capacitance (µF)
- Rated voltage code
- Lot. No.
- Polarity marking (+)

Two marking styles are shown: < Laser marking > and < Other than the above >.

| R. voltage code | | Unit : V | |
|-----------------|----|---------------------|----|
| C | 16 | E ¹ , 1E | 25 |
| D | 20 | V | 35 |

*1: Laser marking

Dimensions (not to scale)

Diagram illustrating the dimensions of the capacitor. Dimensions are shown in millimeters (mm).

| Size code | L | W±0.2 | H | S±0.2 | W1±0.1 |
|-----------|---------|-------|---------|-------|--------|
| D15 | 7.3±0.2 | 4.3 | 1.4±0.1 | 1.3 | 2.4 |
| D2 | 7.3±0.2 | 4.3 | 1.9±0.1 | 1.3 | 2.4 |
| D3L | 7.3±0.3 | 4.3 | 2.8±0.2 | 1.3 | 2.4 |

* Externals of figure are the reference.

Characteristics list

| Rated voltage (V) | Rated temperature (°C) | Category voltage (V) | Category temperature (°C) | Rated capacitance (μF) | Case size (mm) | | | Size code | Specifications | | | | Standard | | Floor life level | Re-flow soldering | |
|-------------------|------------------------|----------------------|---------------------------|------------------------|----------------|-----|-----|-----------|---------------------------------------|-----------------------------|---------------------|-----------------------|--------------|--------------------------|------------------|-------------------|------------|
| | | | | | L | W | H | | Ripple ^{*1} current (mA rms) | ESR ^{*2} (mΩ max.) | tan δ ^{*3} | LC ^{*4} (μA) | Part number | Min. packaging qty (pcs) | | | |
| 16 | 105 | 16 | 105 | 47 | 7.3 | 4.3 | 1.4 | D15 | 1500 | 55 | 0.10 | 75.2 | 16TQC47MYFT | 3000 | 3 | D | |
| | NEW 105 | 16 | 105 | | 7.3 | 4.3 | 1.9 | | D2 | 1450 | 55 | 0.10 | 75.2 | 16TQC47MD2 | | 3000 | A |
| | NEW 105 | 16 | 105 | | 7.3 | 4.3 | 1.9 | | | 1250 | 70 | 0.10 | 75.2 | 16TQC47MBD2 | | 3000 | |
| | NEW 105 | 16 | 105 | 68 | 7.3 | 4.3 | 1.9 | 1500 | | 50 | 0.10 | 108.8 | 16TQC68MD2 | 3000 | | | |
| | NEW 105 | 16 | 105 | 100 | 7.3 | 4.3 | 1.9 | 1800 | | 50 | 0.10 | 160.0 | 16TQC100MD2 | 3000 | | | |
| | 105 | 16 | 105 | 150 | 7.3 | 4.3 | 1.9 | D3L | 1500 | 70 | 0.15 | 240.0 | 1CTQC15173F1 | 3000 | | D | |
| | 105 | 16 | 105 | | 7.3 | 4.3 | 2.8 | | 1800 | 50 | 0.10 | 240.0 | 16TQC150MD3 | 2500 | | B | |
| 105 | 16 | 105 | 220 | | 7.3 | 4.3 | 2.8 | | 1750 | 50 | 0.10 | 352.0 | 16TQC220MD3 | 2500 | C | | |
| 20 | 105 | 20 | 105 | 22 | 7.3 | 4.3 | 1.9 | D2 | 1200 | 90 | 0.10 | 44.0 | 20TQC22MQD | 3000 | D | | |
| | NEW 105 | 20 | 105 | | 33 | 7.3 | 4.3 | | 1.9 | 1400 | 60 | 0.10 | 66.0 | 20TQC33MD2 | 3000 | A | |
| | 105 | 20 | 105 | 47 | 7.3 | 4.3 | 1.4 | D15 | 1500 | 55 | 0.10 | 94.0 | 20TQC47MYFT | 3000 | D | | |
| | | | | | NEW 105 | 20 | 105 | | 7.3 | 4.3 | 1.9 | D2 | 1450 | 55 | 0.10 | 94.0 | 20TQC47MD2 |
| | | | | 100 | 7.3 | 4.3 | 1.9 | D2 | 1250 | 100 | 0.15 | 200.0 | 20TQC100MD2 | 3000 | D | | |
| | | | | | 7.3 | 4.3 | 2.8 | | D3L | 1700 | 55 | 0.10 | 200.0 | 20TQC100MD3 | 2500 | B | |
| 25 | NEW 105 | 25 | 105 | 15 | 7.3 | 4.3 | 1.9 | D2 | 1000 | 90 | 0.10 | 37.5 | 25TQC15MD2 | 3000 | A | | |
| | NEW 105 | 25 | 105 | | 22 | 7.3 | 4.3 | | 1.9 | 1400 | 60 | 0.10 | 55.0 | 25TQC22MD2 | | 3000 | |
| | NEW 105 | 25 | 105 | | 33 | 7.3 | 4.3 | | 1.9 | 1400 | 60 | 0.10 | 82.5 | 25TQC33MD2 | | 3000 | |
| | 105 | 25 | 105 | 68 | 7.3 | 4.3 | 2.8 | D3L | 1400 | 70 | 0.10 | 170.0 | 25TQC68MD3 | 2500 | B | | |
| | 105 | 25 | 105 | | 100 | 7.3 | 4.3 | | 2.8 | 1600 | 60 | 0.10 | 250.0 | 25TQC100MD3 | 2500 | C | |
| 35 | NEW 105 | 35 | 105 | 10 | 7.3 | 4.3 | 1.9 | D2 | 820 | 180 | 0.10 | 35.0 | 35TQC10MD2 | 3000 | A | | |
| | NEW 105 | 35 | 105 | | 15 | 7.3 | 4.3 | | 1.9 | 900 | 150 | 0.10 | 52.5 | 35TQC15MD2 | | 3000 | |
| | NEW 105 | 35 | 105 | | 22 | 7.3 | 4.3 | | 1.9 | 900 | 150 | 0.10 | 77.0 | 35TQC22MD2 | | 3000 | |

NRFND [Not recommended for new design]

| | | | | | | | | | | | | | | | | | |
|----|-----|----|-----|-----|-----|-----|-----|-----|------|------|------|-------|-------------|-------------|-------------|------|------|
| 16 | 105 | 16 | 105 | 33 | 7.3 | 4.3 | 1.9 | D2 | 1400 | 70 | 0.10 | 52.8 | 16TQC33MYFD | 3000 | 3 | D | |
| | 105 | 16 | 105 | | 47 | 7.3 | 4.3 | | 1.9 | 1450 | 55 | 0.10 | 75.2 | 16TQC47MYFD | | | 3000 |
| | 105 | 16 | 105 | | | 7.3 | 4.3 | | 1.9 | 1250 | 70 | 0.10 | 75.2 | 16TQC47MBD | | | 3000 |
| | 105 | 16 | 105 | 68 | 7.3 | 4.3 | 1.9 | | 1500 | 50 | 0.10 | 108.8 | 16TQC68MYF | 3000 | | | |
| | 105 | 16 | 105 | | 100 | 7.3 | 4.3 | | 1.9 | 1800 | 50 | 0.10 | 160.0 | 16TQC100MYF | | | 3000 |
| | 105 | 16 | 105 | 150 | 7.3 | 4.3 | 2.8 | | D3L | 1800 | 50 | 0.10 | 240.0 | 16TQC150MYF | | | 2500 |
| 20 | 105 | 20 | 105 | 33 | 7.3 | 4.3 | 1.9 | D2 | 1400 | 60 | 0.10 | 66.0 | 20TQC33MYFD | 3000 | | | |
| | 105 | 20 | 105 | | 47 | 7.3 | 4.3 | | 1.9 | 1450 | 55 | 0.10 | 94.0 | 20TQC47MYF | 3000 | | |
| | 105 | 20 | 105 | | 100 | 7.3 | 4.3 | | 2.8 | D3L | 1700 | 55 | 0.10 | 200.0 | 20TQC100MYF | 2500 | |
| 25 | 105 | 25 | 105 | 15 | 7.3 | 4.3 | 1.9 | D2 | 1000 | 90 | 0.10 | 38.0 | 25TQC15MYFD | 3000 | | | |
| | 105 | 25 | 105 | | 22 | 7.3 | 4.3 | | 1.9 | 1400 | 60 | 0.10 | 55.0 | 25TQC22MYFD | 3000 | | |
| | 105 | 25 | 105 | 33 | 7.3 | 4.3 | 1.4 | D15 | 1400 | 70 | 0.10 | 55.0 | 25TQC22MYFT | 3000 | | | |
| | 105 | 25 | 105 | | 7.3 | 4.3 | 1.9 | | D2 | 1400 | 60 | 0.10 | 82.5 | 25TQC33MYF | 3000 | | |
| | 105 | 25 | 105 | | 68 | 7.3 | 4.3 | | 2.8 | D3L | 1400 | 70 | 0.10 | 170.0 | 25TQC68MYF | 2500 | |
| 35 | 105 | 35 | 105 | 10 | 7.3 | 4.3 | 1.9 | D2 | 1000 | 120 | 0.10 | 35.0 | 35TQC10MYF | 3000 | | | |
| | 105 | 35 | 105 | | 15 | 7.3 | 4.3 | | 1.9 | 900 | 150 | 0.10 | 52.5 | 35TQC15MYF | 3000 | | |

*1: Ripple current (100 kHz / +105 °C)

*2: ESR (100 kHz / +20 °C)

*3: tan δ (120 Hz / +20 °C)

*4: After 5 minutes

◆ Please refer to each page in this catalog for "Reflow conditions", "Taping specifications" and "Floor life level".

◆ Small order quantity (500 pcs/reel) is available with TQC series. Please contact our sales representative if you prefer it.

Conductive Polymer Tantalum Solid Capacitors Surface Mount Type TA series

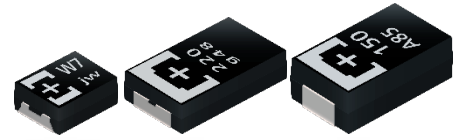

■ This product is not intended for use in any driving application or any other critical functions that affect passenger safety.(e.g. Powertrain, ABS, Engine ECU, Airbag, etc.)
If the intended use of TA/TV series products is for use in other automotive related applications, please contact our sales team. All requests are subject to approval.

Features

- Guaranteed at 85 °C 85 %RH
- RoHS compliance, Halogen free

Specifications

| Size code | B2 | D2E | D3L |
|-----------------------------|---|--|------------------|
| Category temp. range | -55 °C to +105 °C | | |
| Rated voltage range | 4.0 V to 10 V | 2.5 V to 6.3 V | 2.5 V to 10 V |
| Category voltage range | 4.0 V to 10 V | 2.5 V to 6.3 V | 2.5 V to 10 V |
| Rated capacitance range | 47 μF to 100 μF | 150 μF to 470 μF | 150 μF to 680 μF |
| Capacitance tolerance | ±20 % (120 Hz / +20 °C) | | |
| Leakage current | Please see the attached characteristics list | | |
| Dissipation factor(tan δ) | Please see the attached characteristics list | | |
| Surge voltage (V) | Rated voltage × 1.15 | | |
| Endurance | +105 °C 2000 h (B2 size : 1000 h) , rated voltage applied | | |
| | Capacitance change | Within ±20 % of the initial value | |
| | Dissipation factor(tan δ) | ≤ 1.5 times of the initial limit | |
| | Leakage current | Within the initial limit | |
| Damp heat (Steady State) | +85 °C, 85 % to 90 % RH, 500 h, rated voltage applied | | |
| | Capacitance change | Within +50 %, -20 % of the initial value (2R5TAE470M (F), 2R5TAE330M (I, F), 2R5TAE220M (F, 9)) | |
| | Dissipation factor(tan δ) | ≤ 1.5 times of the initial limit | |
| | Leakage current | Within the initial limit | |

Marking

< B2 size >

< D2E, D3L size >

| | |
|---|-----|
| e | 2.5 |
| g | 4 |

| | |
|---|-----|
| j | 6.3 |
| A | 10 |

| | |
|----|----|
| S7 | 47 |
| W7 | 68 |

| | |
|----|-----|
| A8 | 100 |
|----|-----|

Dimensions (not to scale)

| Size code | L | W±0.2 | H | S±0.2 | W1±0.1 |
|-----------|---------|-------|---------|-------|--------|
| B2 | 3.5±0.2 | 2.8 | 1.9±0.1 | 0.8 | 2.2 |
| D2E | 7.3±0.3 | 4.3 | 1.8±0.1 | 1.3 | 2.4 |
| D3L | 7.3±0.3 | 4.3 | 2.8±0.2 | 1.3 | 2.4 |

* Externals of figure are the reference.

Characteristics list

| Rated voltage (V) | Rated temperature (°C) | Category voltage (V) | Category temperature (°C) | Rated capacitance (μF) | Case size (mm) | | | Size code | Specifications | | | | Standard | | Floor life level | | |
|-------------------|------------------------|----------------------|---------------------------|------------------------|----------------|-----|-----|-----------|---------------------------------------|-----------------------------|---------------------|-----------------------|-------------|--------------------------|--------------------|--------------------|------|
| | | | | | L | W | H | | Ripple ^{*1} current (mA rms) | ESR ^{*2} (mΩ max.) | tan δ ^{*3} | LC ^{*4} (μA) | Part number | Min. packaging qty (pcs) | Reflow temp ≤260°C | Reflow temp ≤250°C | |
| 2.5 | 105 | 2.5 | 105 | 220 | 7.3 | 4.3 | 1.8 | D2E | 3900 | 9 | 0.10 | 110.0 | 2R5TAE220M9 | 3000 | 3 | 3 | |
| | 105 | 2.5 | 105 | | 7.3 | 4.3 | 1.8 | | 3100 | 15 | 0.10 | 55.0 | 2R5TAE220MF | 3000 | | | |
| | 105 | 2.5 | 105 | | 7.3 | 4.3 | 1.8 | | 2400 | 25 | 0.10 | 55.0 | 2R5TAE220M | 3000 | | | |
| | 105 | 2.5 | 105 | 330 | 7.3 | 4.3 | 1.8 | | 3100 | 15 | 0.10 | 82.5 | 2R5TAE330MF | 3000 | | | |
| | 105 | 2.5 | 105 | | 7.3 | 4.3 | 1.8 | | 2800 | 18 | 0.10 | 82.5 | 2R5TAE330MI | 3000 | | | |
| | 105 | 2.5 | 105 | | 7.3 | 4.3 | 1.8 | | 2400 | 25 | 0.10 | 82.5 | 2R5TAE330M | 3000 | | | |
| | 105 | 2.5 | 105 | 470 | 7.3 | 4.3 | 1.8 | | 3100 | 15 | 0.10 | 117.5 | 2R5TAE470MF | 3000 | | | |
| | 105 | 2.5 | 105 | | 7.3 | 4.3 | 1.8 | | 2400 | 25 | 0.10 | 117.5 | 2R5TAE470M | 3000 | | | |
| | 105 | 2.5 | 105 | 680 | 7.3 | 4.3 | 2.8 | | D3L | 3100 | 15 | 0.10 | 170.0 | 2R5TAE680MFL | | | 2500 |
| | 105 | 2.5 | 105 | | 7.3 | 4.3 | 2.8 | | | 2400 | 25 | 0.10 | 170.0 | 2R5TAE680ML | | | 2500 |
| 4.0 | 105 | 4.0 | 105 | 100 | 3.8 | 2.8 | 1.9 | B2 | 1100 | 70 | 0.08 | 40.0 | 4TAB100M | 2000 | 3 | 3 | |
| | 105 | 4.0 | 105 | 220 | 7.3 | 4.3 | 1.8 | D2E | 2800 | 18 | 0.10 | 88.0 | 4TAE220MI | 3000 | | | |
| | 105 | 4.0 | 105 | | 7.3 | 4.3 | 1.8 | | 2400 | 25 | 0.10 | 88.0 | 4TAE220M | 3000 | | | |
| | 105 | 4.0 | 105 | 470 | 7.3 | 4.3 | 2.8 | D3L | 2800 | 18 | 0.10 | 188.0 | 4TAE470MIL | 2500 | | | |
| | 105 | 4.0 | 105 | | 7.3 | 4.3 | 2.8 | | 2400 | 25 | 0.10 | 188.0 | 4TAE470ML | 2500 | | | |
| 6.3 | 105 | 6.3 | 105 | 47 | 3.5 | 2.8 | 1.9 | B2 | 1100 | 70 | 0.08 | 29.6 | 6TAB47M | 2000 | 3 | 3 | |
| | 105 | 6.3 | 105 | 68 | 3.5 | 2.8 | 1.9 | | 1100 | 70 | 0.08 | 42.8 | 6TAB68M | 2000 | | | |
| | 105 | 6.3 | 105 | 150 | 7.3 | 4.3 | 1.8 | D2E | 2400 | 25 | 0.10 | 94.5 | 6TAE150M | 3000 | | | |
| | 105 | 6.3 | 105 | 220 | 7.3 | 4.3 | 1.8 | | 2800 | 18 | 0.10 | 138.6 | 6TAE220MI | 3000 | | | |
| | 105 | 6.3 | 105 | | 7.3 | 4.3 | 1.8 | | 2400 | 25 | 0.10 | 138.6 | 6TAE220M | 3000 | | | |
| | 105 | 6.3 | 105 | 330 | 7.3 | 4.3 | 2.8 | D3L | 2400 | 25 | 0.10 | 207.9 | 6TAE330ML | 2500 | | | |
| | 10 | 105 | 10 | 105 | 47 | 3.5 | 2.8 | 1.9 | B2 | 1100 | 70 | 0.08 | 47.0 | 10TAB47M | | | 2000 |
| 105 | | 10 | 105 | 150 | 7.3 | 4.3 | 2.8 | D3L | 2400 | 25 | 0.10 | 150.0 | 10TAE150ML | 2500 | | | |
| 105 | | 10 | 105 | 220 | 7.3 | 4.3 | 2.8 | | 2400 | 25 | 0.10 | 220.0 | 10TAE220ML | 2500 | | | |

*1: Ripple current (100 kHz / +45 °C)

*2: ESR (100 kHz / +20 °C)

*3: tan δ (120 Hz / +20 °C)

*4: After 5 minutes

◆ Please refer to each page in this catalog for "Reflow conditions", "Taping specifications" and "Floor life level".

Conductive Polymer Tantalum Solid Capacitors Surface Mount Type TV series

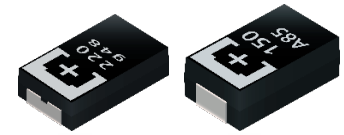

■ This product is not intended for use in any driving application or any other critical functions that affect passenger safety.(e.g. Powertrain, ABS, Engine ECU, Airbag, etc.)
If the intended use of TA/TV series products is for use in other automotive related applications, please contact our sales team. All requests are subject to approval.

Features

- Guaranteed at 85 °C 85 %RH
- Guaranteed at 125 °C
- RoHS compliance, Halogen free

Specifications

| Size code | D2E | D3L |
|---------------------------|--|--|
| Category temp. range | -55 °C to +125 °C | |
| Rated voltage range | 6.3 V to 10 V | 10 V |
| Category voltage range | 4.0 V to 6.3 V | 6.3 V |
| Rated capacitance range | 68 μF to 150 μF | 150 μF |
| Capacitance tolerance | ±20 % (120 Hz / +20 °C) | |
| Leakage current | Please see the attached characteristics list | |
| Dissipation factor(tan δ) | Please see the attached characteristics list | |
| Surge voltage (V) | Rated voltage × 1.15 | |
| Endurance | +125 °C 1000 h, category voltage applied (+105 °C 2000 h, rated voltage applied) | |
| | Temperature | 125 °C |
| | Capacitance change | Within ±20% of the initial value |
| | Dissipation factor(tan δ) | ≤ 2 times of the initial limit |
| Damp heat (Steady State) | +85 °C, 85 % to 90 % RH, 500 h, rated voltage applied | |
| | Capacitance change | Within +40 %, -20 % of the initial value |
| | Dissipation factor(tan δ) | ≤ 1.5 times of the initial limit |
| | Leakage current | Within the initial limit |

Marking

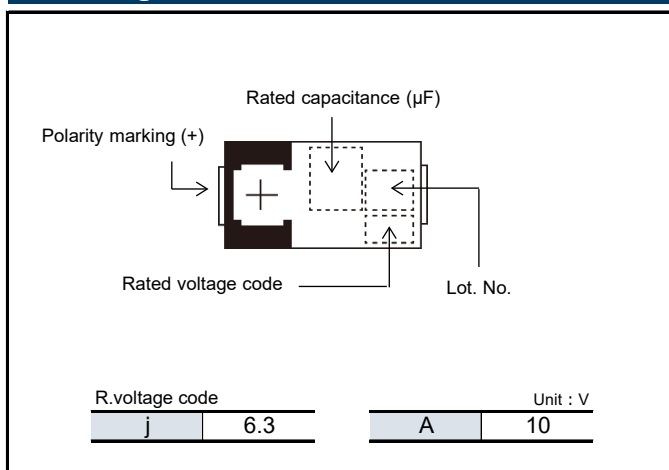

Dimensions (not to scale)

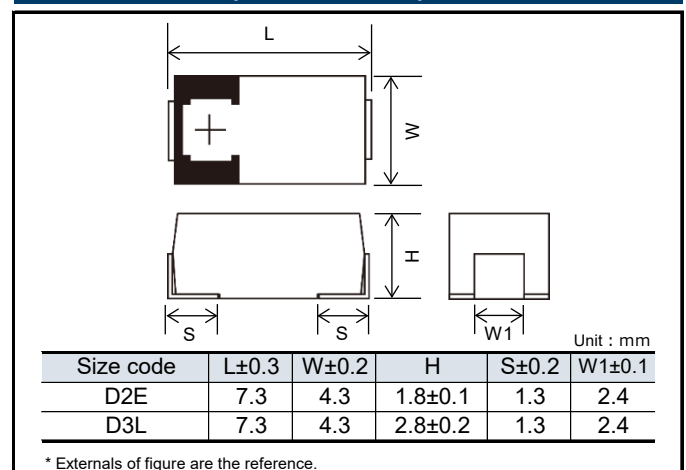

Characteristics list

| Rated voltage (V) | Rated temperature (°C) | Category voltage (V) | Category temperature (°C) | Rated capacitance (μF) | Case size (mm) | | | Size code | Specifications | | | | Standard | | Floor life level | |
|-------------------|------------------------|----------------------|---------------------------|------------------------|----------------|-----|-----|-----------|---------------------------------------|-----------------------------|---------------------|-----------------------|-------------|---------------------------|--------------------|--------------------|
| | | | | | L | W | H | | Ripple current (mA rms) ^{*1} | ESR ^{*2} (mΩ max.) | tan δ ^{*3} | LC ^{*4} (μA) | Part number | Min. packaging q'ty (pcs) | Reflow temp ≤260°C | Reflow temp ≤250°C |
| 6.3 | 105 | 4.0 | 125 | 150 | 7.3 | 4.3 | 1.8 | D2E | 2400 | 25 | 0.10 | 94.5 | 6TVE150M | 3000 | 5 | 3 |
| | | | | | | | | | | | | | | | | |
| 10 | 105 | 6.3 | 125 | 150 | 7.3 | 4.3 | 2.8 | D3L | 2400 | 25 | 0.10 | 150.0 | 10TVE150ML | 2500 | | |

*1: Ripple current (100 kHz / +45 °C) *2: ESR (100 kHz / +20 °C) *3: tan δ (120 Hz / +20 °C) *4: After 5 minutes

◆ Please refer to each page in this catalog for "Reflow conditions", "Taping specifications" and "Floor life level".

Conductive Polymer Tantalum Solid Capacitors Surface Mount Type TH series

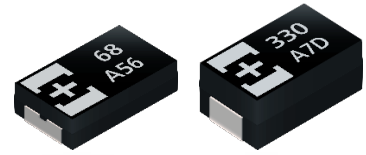

Features

- Guaranteed at 125 °C 1000 h
- RoHS compliance, Halogen free

Specifications

| Size code | D2E | D2 | D3L | D4 |
|---------------------------|--|--|------------------|------------------|
| Category temp. range | -55 °C to +125 °C | | | |
| Rated voltage range | 2.5 V to 6.3 V | 2.5 V to 10 V | 4.0 V to 6.3 V | 6.3 V to 10 V |
| Category voltage range | 1.6 V to 4.0 V | 1.6 V to 6.3 V | 2.5 V to 4.0 V | 4.0 V to 6.3 V |
| Rated capacitance range | 150 μF to 330 μF | 68 μF to 220 μF | 220 μF to 330 μF | 220 μF to 470 μF |
| Capacitance tolerance | ±20 % (120 Hz / +20 °C) | | | |
| Leakage current | Please see the attached characteristics list | | | |
| Dissipation factor(tan δ) | Please see the attached characteristics list | | | |
| Surge voltage (V) | Rated voltage × 1.15 | | | |
| Endurance | +125 °C 1000 h, category voltage applied | | | |
| | Capacitance change | Within ±20 % of the initial value | | |
| | Dissipation factor(tan δ) | ≤ 2 times of the initial limit | | |
| | Leakage current | ≤ 2 times of the initial limit | | |
| Damp heat (Steady State) | +60 °C, 90 % to 95 % RH, 500 h, No-applied voltage | | | |
| | Capacitance change | Within +40 %, -20 % of the initial value | | |
| | Dissipation factor(tan δ) | ≤ 1.5 times of the initial limit | | |
| | Leakage current | ≤ 3 times of the initial limit | | |

Marking

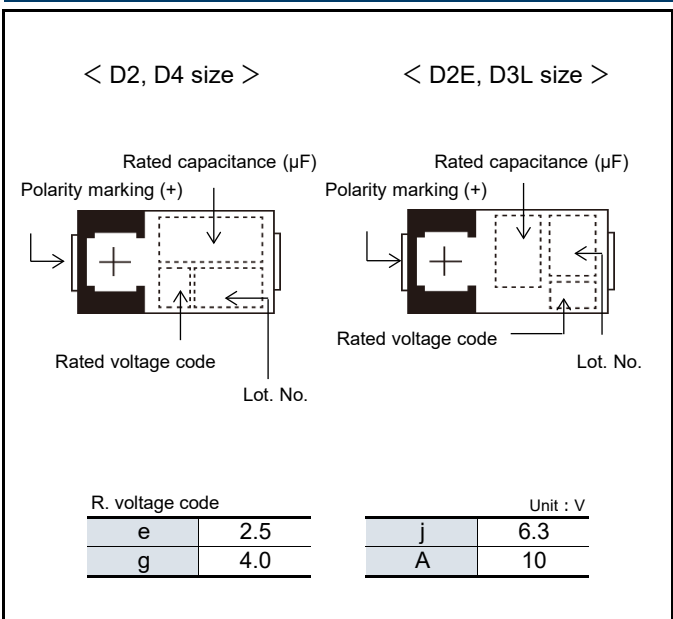

Dimensions (not to scale)

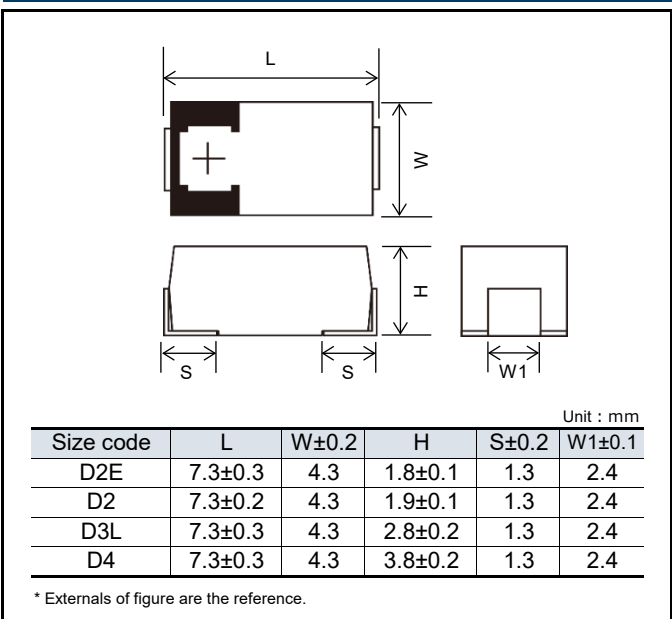

Characteristics list

| Series | Rated voltage (V) | Rated temperature (°C) | Category voltage (V) | Category temp. (°C) | Rated capacitance (μF) | Case size (mm) | | | Size code | Specifications | | | | Standard | | Floor life level | |
|--------|-------------------|------------------------|----------------------|---------------------|------------------------|----------------|-----|-----|-----------|---------------------------------------|-----------------------------|---------------------|-----------------------|-------------|---------------------------|--------------------|--------------------|
| | | | | | | L | W | H | | Ripple ^{*1} current (mA rms) | ESR ^{*2} (mΩ max.) | tan δ ^{*3} | LC ^{*4} (μA) | Part number | Min. packaging q'ty (pcs) | Reflow temp ≤260°C | Reflow temp ≤250°C |
| THB | 4.0 | 105 | 2.5 | 125 | 330 | 7.3 | 4.3 | 2.8 | D3L | 2000 | 40 | 0.10 | 132.0 | 4THB330ML | 2500 | - | 5 |
| | 6.3 | 105 | 4.0 | 125 | 220 | 7.3 | 4.3 | 2.8 | | 2000 | 40 | 0.10 | 138.6 | 6THB220ML | 2500 | | |
| | | 10 | 105 | 4.0 | 125 | 330 | 7.3 | 4.3 | 3.8 | D4 | 3000 | 40 | 0.10 | 207.9 | 6THB330M | | |
| | 105 | | 4.0 | 125 | 470 | 7.3 | 4.3 | 3.8 | 3000 | | 35 | 0.10 | 296.1 | 6THB470M | 2000 | | |
| | 105 | | 6.3 | 125 | 220 | 7.3 | 4.3 | 3.8 | 3000 | | 40 | 0.10 | 220.0 | 10THB220M | 2000 | | |
| | 105 | | 6.3 | 125 | 330 | 7.3 | 4.3 | 3.8 | 3000 | | 35 | 0.10 | 330.0 | 10THB330M | 2000 | | |
| THC | 2.5 | 105 | 1.6 | 125 | 220 | 7.3 | 4.3 | 1.9 | D2 | 1700 | 45 | 0.10 | 55.0 | 2R5THC220M | 3000 | | |
| | 10 | 105 | 6.3 | 125 | 68 | 7.3 | 4.3 | 1.9 | | 1700 | 45 | 0.10 | 68.0 | 10THC68M | 3000 | | |
| THE | 2.5 | 105 | 1.6 | 125 | 330 | 7.3 | 4.3 | 1.8 | D2E | 3100 | 15 | 0.10 | 82.5 | 2R5THE330MF | 3000 | | |
| | | 105 | 1.6 | 125 | | 7.3 | 4.3 | 1.8 | | 2800 | 18 | 0.10 | 82.5 | 2R5THE330MI | 3000 | | |
| | | 105 | 1.6 | 125 | | 7.3 | 4.3 | 1.8 | | 2400 | 25 | 0.10 | 82.5 | 2R5THE330M | 3000 | | |
| | 4.0 | 105 | 2.5 | 125 | 220 | 7.3 | 4.3 | 1.8 | | 3100 | 15 | 0.10 | 88.0 | 4THE220MF | 3000 | | |
| | | 105 | 2.5 | 125 | | 7.3 | 4.3 | 1.8 | | 2800 | 18 | 0.10 | 88.0 | 4THE220MI | 3000 | | |
| | | 105 | 2.5 | 125 | | 7.3 | 4.3 | 1.8 | | 2400 | 25 | 0.10 | 88.0 | 4THE220M | 3000 | | |
| | 6.3 | 105 | 4.0 | 125 | 150 | 7.3 | 4.3 | 1.8 | | 2800 | 18 | 0.10 | 94.5 | 6THE150MI | 3000 | | |
| | | 105 | 4.0 | 125 | | 7.3 | 4.3 | 1.8 | | 2400 | 25 | 0.10 | 94.5 | 6THE150M | 3000 | | |

*1: Ripple current (100 kHz / +45 °C)

*2: ESR (100 kHz / +20 °C)

*3: tan δ (120 Hz / +20 °C)

*4: After 5 minutes

◆ Please refer to each page in this catalog for "Reflow conditions", "Taping specifications" and "Floor life level".

Conductive Polymer Tantalum Solid Capacitors Surface Mount Type TPB series

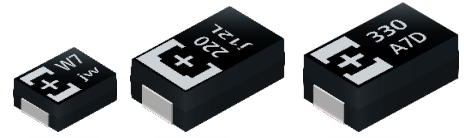

Features

- Standard
- RoHS compliance, Halogen free

Specifications

| Size code | B2 | D3L | D4 |
|-----------------------------|---|---|------------------|
| Category temp. range | -55 °C to +105 °C | | |
| Rated voltage range | 4.0 V to 10 V | 4.0 V to 10 V | 6.3 V to 10 V |
| Category voltage range | 4.0 V to 10 V | 4.0 V to 10 V | 6.3 V to 10 V |
| Rated capacitance range | 33 μF to 68 μF | 150 μF to 330 μF | 220 μF to 470 μF |
| Capacitance tolerance | ±20 % (120 Hz / +20 °C) | | |
| Leakage current | Please see the attached characteristics list | | |
| Dissipation factor(tan δ) | Please see the attached characteristics list | | |
| Surge voltage (V) | Rated voltage × 1.15 | | |
| Endurance | +105 °C 2000 h, (B2 size : 1000 h) rated voltage applied Rated temp. +85 °C 1000 h rated voltage applied | | |
| | Capacitance change | Within ±20 % of the initial value | |
| | Dissipation factor(tan δ) | ≤ 1.5 times of the initial limit | |
| | Leakage current | Within the initial limit | |
| Damp heat (Steady State) | +60 °C, 90 % to 95 % RH, 500 h, No-applied voltage | | |
| | Capacitance change | Within +40 %, -20 % of the initial value (Except for above model) | |
| | Dissipation factor(tan δ) | ≤ 1.5 times of the initial limit | |
| | Leakage current | ≤ 3 times of the initial limit | |

Marking

< B2 size >

Rated capacitance code

Polarity marking (+)

Rated voltage code Lot. No.

< D3L size >

Rated capacitance (μF)

Polarity marking (+)

Rated voltage code Lot. No.

< D4 size >

Rated capacitance (μF)

Polarity marking (+)

Rated voltage code Lot. No.

| R. voltage code | Unit : V |
|----------------------------|----------|
| g 4.0 j 6.3 A 10 | |

| R. capacitance code | Unit : μF |
|--|-----------|
| < B2 size > N7 33 S7 47 W7 68 | |

Dimensions (not to scale)

| Size code | L | W±0.2 | H | S±0.2 | W1±0.1 |
|-----------|---------|-------|---------|-------|--------|
| B2 | 3.5±0.2 | 2.8 | 1.9±0.1 | 0.8 | 2.2 |
| D3L | 7.3±0.3 | 4.3 | 2.8±0.2 | 1.3 | 2.4 |
| D4 | 7.3±0.3 | 4.3 | 3.8±0.2 | 1.3 | 2.4 |

* Externals of figure are the reference.

Characteristics list

| Rated voltage (V) | Rated temperature (°C) | Category voltage (V) | Category temperature (°C) | Rated capacitance (µF) | Case size (mm) | | | Size code | Specifications | | | | Standard | | Floor life level | |
|-------------------|------------------------|----------------------|---------------------------|------------------------|----------------|-----|------|-----------|---------------------------------------|-----------------------------|---------------------|-----------------------|-------------|---------------------------|--------------------|--------------------|
| | | | | | L | W | H | | Ripple ^{*1} current (mA rms) | ESR ^{*2} (mΩ max.) | tan δ ^{*3} | LC ^{*4} (µA) | Part number | Min. packaging q'ty (pcs) | Reflow temp ≤260°C | Reflow temp ≤250°C |
| 4.0 | 105 | 4.0 | 105 | 68 | 3.5 | 2.8 | 1.9 | B2 | 1100 | 70 | 0.08 | 27.2 | 4TPB68M | 2000 | | 3 |
| | NRFND 105 | 4.0 | 105 | 330 | 7.3 | 4.3 | 2.8 | D3L | 2000 | 40 | 0.10 | 132 | 4TPB330ML | 2500 | | 2a |
| 6.3 | 105 | 6.3 | 105 | 33 | 3.5 | 2.8 | 1.9 | B2 | 1100 | 70 | 0.08 | 20.7 | 6TPB33M | 2000 | 3 | 3 |
| | 105 | 6.3 | 105 | 68 | 3.5 | 2.8 | 1.9 | | 1100 | 70 | 0.08 | 42.8 | 6TPB68M | 2000 | | |
| | NRFND 105 | 6.3 | 105 | 220 | 7.3 | 4.3 | 2.8 | D3L | 2000 | 40 | 0.10 | 138.6 | 6TPB220ML | 2500 | | 2a |
| | NRFND 105 | 6.3 | 105 | | 7.3 | 4.3 | 2.8 | | 1750 | 50 | 0.10 | 138.6 | 6TPB220MTL | 2500 | | |
| | 85 | 5.0 | 105 | 330 | 7.3 | 4.3 | 2.8 | D3L | 2000 | 40 | 0.10 | 207.9 | 6TPB330MAL | 2500 | | 2a |
| | 105 | 6.3 | 105 | | 7.3 | 4.3 | 2.8 | | 2000 | 40 | 0.10 | 207.9 | 6TPB330ML | 2500 | | |
| | 105 | 6.3 | 105 | | 7.3 | 4.3 | 3.8 | D4 | 3000 | 40 | 0.10 | 207.9 | 6TPB330M | 2000 | | |
| | 105 | 6.3 | 105 | | 7.3 | 4.3 | 2.8 | D3L | 1850 | 45 | 0.10 | 207.9 | 6TPB330MVL | 2500 | | |
| | 105 | 6.3 | 105 | 470 | 7.3 | 4.3 | 3.8 | D4 | 3000 | 35 | 0.15 | 296.1 | 6TPB470M | 2000 | | |
| | 10 | 105 | 10 | 105 | 33 | 3.5 | 2.8 | 1.9 | B2 | 1100 | 70 | 0.08 | 33.0 | 10TPB33M | | 2000 |
| 105 | | 10 | 105 | 47 | 3.5 | 2.8 | 1.9 | 1100 | | 70 | 0.08 | 47.0 | 10TPB47M | 2000 | | |
| 105 | | 10 | 105 | 150 | 7.3 | 4.3 | 2.8 | D3L | 2000 | 40 | 0.10 | 150.0 | 10TPB150ML | 2500 | 2a | |
| 105 | | 10 | 105 | | 7.3 | 4.3 | 2.8 | | 1700 | 55 | 0.10 | 150.0 | 10TPB150MGL | 2500 | | |
| 105 | | 10 | 105 | 220 | 7.3 | 4.3 | 2.8 | D3L | 2000 | 40 | 0.10 | 220.0 | 10TPB220ML | 2500 | - | |
| 105 | | 10 | 105 | | 7.3 | 4.3 | 3.8 | | 3000 | 40 | 0.10 | 220.0 | 10TPB220M | 2000 | 3 | |
| NRFND 105 | | 10 | 105 | 330 | 7.3 | 4.3 | 3.8 | D4 | 3000 | 35 | 0.10 | 330.0 | 10TPB330M | 2000 | - | |
| 105 | 10 | 105 | 7.3 | | 4.3 | 3.8 | 2800 | | 40 | 0.10 | 330.0 | 10TPB330MW | 2000 | - | | |

*1: Ripple current (100 kHz / +45 °C)

NRFND Not recommended for new design

*2: ESR (100 kHz / +20 °C)

*3: tan δ (120 Hz / +20 °C)

*4: After 5 minutes

◆ Please refer to each page in this catalog for "Reflow conditions", "Taping specifications" and "Floor life level".

Conductive Polymer Tantalum Solid Capacitors Surface Mount Type TC series

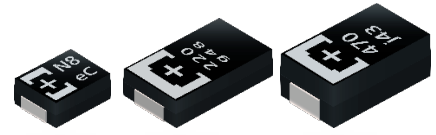

Features

- Guaranteed at 125 °C 1000 h
- RoHS compliance, Halogen free

Specifications

| Size code | B2 | D2E | D3L | D4 |
|---------------------------|--|--|------------------|-------------------|
| Category temp. range | -55 °C to +125 °C | | | |
| Rated voltage range | 2.5 V | 4.0 V to 6.3 V | 2.5 V to 10 V | |
| Category voltage range | 2.0 V | 3.2 V to 5.0 V | 2.0 V to 8.0 V | |
| Rated capacitance range | 330 μF | 100 μF to 330 μF | 150 μF to 680 μF | 330 μF to 1000 μF |
| Capacitance tolerance | ±20 % (120 Hz / +20 °C) | | | |
| Leakage current | Please see the attached characteristics list | | | |
| Dissipation factor(tan δ) | Please see the attached characteristics list | | | |
| Surge voltage (V) | Rated voltage × 1.15 | | | |
| Endurance | +125 °C 1000 h, category voltage applied | | | |
| | Capacitance change | Within ±20 % of the initial value | | |
| | Dissipation factor(tan δ) | ≤ 2 times of the initial limit | | |
| | Leakage current | ≤ 2 times of the initial limit | | |
| Damp heat (Steady State) | +60 °C, 90 % to 95 % RH, 500 h, No-applied voltage | | | |
| | Capacitance change | Within +50 %, -20 % of the initial value (ETCF1000M6H(5H)) | | |
| | | Within +40 %, -20 % of the initial value | | |
| | Dissipation factor(tan δ) | ≤ 1.5 times of the initial limit | | |
| | Leakage current | ≤ 3 times of the initial limit | | |

Marking

< B2 size >

< D2E, D3L, D4 size >

| | |
|---|-----|
| e | 2.5 |
| g | 4.0 |

| | |
|---|-----|
| j | 6.3 |
| A | 10 |

< B2 size >

| | |
|----|-----|
| N8 | 330 |
|----|-----|

Dimensions (not to scale)

| Size code | L | W±0.2 | H | S±0.2 | W1±0.1 |
|-----------|---------|-------|---------|-------|--------|
| B2 | 3.5±0.2 | 2.8 | 1.9±0.1 | 0.8 | 2.2 |
| D2E | 7.3±0.3 | 4.3 | 1.8±0.1 | 1.3 | 2.4 |
| D3L | 7.3±0.3 | 4.3 | 2.8±0.2 | 1.3 | 2.4 |
| D4 | 7.3±0.3 | 4.3 | 3.8±0.2 | 1.3 | 2.4 |

* Externals of figure are the reference.

Characteristics list

| Series | Rated voltage (V) | Rated temperature (°C) | Category voltage (V) | Category temp. (°C) | Rated capacitance (µF) | Case size (mm) | | | Size code | Specifications | | | | Standard | | Floor life level | | | | | | | |
|--------|-------------------|------------------------|----------------------|---------------------|------------------------|----------------|------|------|-----------|-------------------------|-----------------------------|---------------------|-----------------------|-------------|---------------------------|--------------------|--------------------|-------------|------------|-------------|-------|------------|------|
| | | | | | | L | W | H | | Ripple current (mA rms) | ESR* ² (mΩ max.) | tan δ* ³ | LC* ⁴ (µA) | Part number | Min. packaging q'ty (pcs) | Reflow temp ≤260°C | Reflow temp ≤250°C | | | | | | |
| TCE | 2.5 | 105 | 2.0 | 125 | 330 | 3.5 | 2.8 | 1.9 | B2 | 3200 | 9/300kHz | 0.08 | 165.0 | ETCE330M9GB | 2000 | 3 | 2a | | | | | | |
| | | | | | | 680 | 7.3 | 4.3 | 2.8 | D3L | 3500 | 12 | 0.10 | 170.0 | ETCE680MCL | | | 2500 | | | | | |
| | | | | | 7.3 | | 4.3 | 2.8 | 3100 | | 15 | 0.10 | 170.0 | ETCE680MFL | 2500 | | | | | | | | |
| | | | | | 4.0 | 105 | 3.2 | 125 | 1000 | 7.3 | 4.3 | 3.8 | D4 | 3900 | 15 | | | 0.15 | 250.0 | ETCE1000MF | 2000 | | |
| | 220 | 7.3 | 4.3 | 1.8 | | | | | | D2E | 2800 | 18 | 0.10 | 60.0 | 4TCE150MI | | | 3000 | | | | | |
| | | 7.3 | 4.3 | 1.8 | | | | | | | 3100 | 15 | 0.10 | 88.0 | 4TCE220MF | | | 3000 | | | | | |
| | 330 | 7.3 | 4.3 | 1.8 | | | | | 2800 | | 18 | 0.10 | 88.0 | 4TCE220MI | 3000 | | | | | | | | |
| | | 7.3 | 4.3 | 1.8 | | | | | 2400 | | 25 | 0.10 | 88.0 | 4TCE220M | 3000 | | | | | | | | |
| | 470 | 105 | 3.2 | 125 | | | | | 330 | 7.3 | 4.3 | 1.8 | D3L | 2800 | 18 | | | 0.10 | 132.0 | 4TCE330MI | 3000 | | |
| | | | | | | 7.3 | 4.3 | 1.8 | | 2400 | 25 | 0.10 | | 132.0 | 4TCE330M | | | 3000 | | | | | |
| | | | | | | 7.3 | 4.3 | 2.8 | | 3500 | 12 | 0.10 | | 188.0 | 4TCE470MCL | | | 2500 | | | | | |
| | | 470 | 7.3 | 4.3 | | 2.8 | 3100 | 15 | 0.10 | 188.0 | 4TCE470MFL | 2500 | | | | | | | | | | | |
| | | | 7.3 | 4.3 | | 2.8 | 2800 | 18 | 0.10 | 188.0 | 4TCE470MIL | 2500 | | | | | | | | | | | |
| | | | 7.3 | 4.3 | | 2.8 | 2400 | 25 | 0.10 | 188.0 | 4TCE470ML | 2500 | | | | | | | | | | | |
| | 6.3 | 105 | 5.0 | 125 | | 100 | 7.3 | 4.3 | 1.8 | D2E | 2800 | 18 | 0.10 | 63.0 | 6TCE100MI | | | 3000 | | | | | |
| | | | | | 7.3 | | 4.3 | 1.8 | 2400 | | 25 | 0.10 | 63.0 | 6TCE100M | 3000 | | | | | | | | |
| | | | | | 150 | | 7.3 | 4.3 | 1.8 | | 3100 | 15 | 0.10 | 94.5 | 6TCE150MF | | | 3000 | | | | | |
| | | | | | | | 7.3 | 4.3 | 1.8 | | 2800 | 18 | 0.10 | 94.5 | 6TCE150MI | | | 3000 | | | | | |
| | | | | | 220 | 7.3 | 4.3 | 1.8 | 2400 | | 25 | 0.15 | 94.5 | 6TCE150M | 3000 | | | | | | | | |
| | | | | | | 330 | 7.3 | 4.3 | 1.8 | | 2800 | 18 | 0.15 | 138.6 | 6TCE220MI | | | 3000 | | | | | |
| | | | | | | | 7.3 | 4.3 | 1.8 | | 2400 | 25 | 0.15 | 138.6 | 6TCE220M | | | 3000 | | | | | |
| | | | | | | 470 | 105 | 5.0 | 125 | | 330 | 7.3 | 4.3 | 2.8 | D3L | | | 3100 | 15 | 0.10 | 207.9 | 6TCE330MFL | 2500 |
| | | 7.3 | 4.3 | 2.8 | | | | | | 2800 | | 18 | 0.10 | 207.9 | | | | 6TCE330MIL | 2500 | | | | |
| | | 7.3 | 4.3 | 2.8 | | | | | | 2400 | | 25 | 0.10 | 207.9 | | | | 6TCE330ML | 2500 | | | | |
| | | 470 | 7.3 | 4.3 | 3.8 | | 3500 | 18 | 0.15 | 296.1 | | 6TCE470MI | 2000 | | | | | | | | | | |
| | | | 7.3 | 4.3 | 3.8 | | 3000 | 25 | 0.15 | 296.1 | | 6TCE470M | 2000 | | | | | | | | | | |
| | | | 7.3 | 4.3 | 3.8 | | 3500 | 18 | 0.15 | 428.4 | | 6TCE680MI | 2000 | | | | | | | | | | |
| | | 10 | 105 | 8.0 | 125 | 220 | 7.3 | 4.3 | 2.8 | D4 | 3000 | 25 | 0.15 | 428.4 | 6TCE680M | | | 2000 | | | | | |
| | 7.3 | | | | | | 4.3 | 2.8 | 2800 | | 18 | 0.10 | 220.0 | 10TCE220MIL | 2500 | | | | | | | | |
| | 7.3 | | | | | | 4.3 | 2.8 | 2400 | | 25 | 0.10 | 220.0 | 10TCE220ML | 2500 | | | | | | | | |
| 330 | 7.3 | | 4.3 | 3.8 | 3000 | | 25 | 0.10 | 330.0 | | 10TCE330M | 2000 | | | | | | | | | | | |
| | 680 | | 7.3 | 4.3 | 2.8 | | D3L | 4400 | 6 | | 0.10 | 170.0 | ETCF680M6L | 2500 | | | | | | | | | |
| | | | 7.3 | 4.3 | 2.8 | | | 4400 | 7 | | 0.10 | 170.0 | ETCF680M7L | 2500 | | | | | | | | | |
| TCF | 2.5 | 105 | 2.0 | 125 | 680 | 7.3 | 4.3 | 2.8 | D3L | 4400 | 10 | 0.10 | 170.0 | ETCF680ML | 2500 | | | | | | | | |
| | | | | | | | | | | 1000 | 6100 | 5 | 0.10 | 170.0 | ETCF680M5H | 2000 | | | | | | | |
| | | | | | | | | | | | 7.3 | 4.3 | 3.8 | 6100 | 5 | 0.10 | 250.0 | ETCF1000M5H | 2000 | | | | |
| | | | | | | 4.0 | 105 | 3.2 | | 125 | 330 | 7.3 | 4.3 | 2.8 | D4 | 5600 | 6 | 0.10 | 250.0 | ETCF1000M6H | 2000 | | |
| | | | | | | | | | | | | 470 | 7.3 | 4.3 | | 2.8 | D3L | 4000 | 12 | 0.10 | 132.0 | 4TCF330ML | 2500 |
| | | | | | | | | | | | | | 7.3 | 4.3 | | 2.8 | | 4400 | 10 | 0.10 | 188.0 | 4TCF470ML | 2500 |
| | 6.3 | 105 | 3.2 | 125 | 680 | | 7.3 | 4.3 | 3.8 | D4 | | 4400 | 10 | 0.10 | | 272.0 | 4TCF680MAH | 2000 | | | | | |
| | | | | | | | 220 | 7.3 | 4.3 | | | 2.8 | D3L | 4600 | | 9 | 0.10 | 138.6 | 6TCF220M9L | 2500 | | | |
| | | | | | | | | | | | | | | 7.3 | | 4.3 | 2.8 | 4000 | 12 | 0.10 | 138.6 | 6TCF220ML | 2500 |
| | | 470 | 105 | 5.0 | | 125 | 330 | 7.3 | 4.3 | | 2.8 | D4 | 3900 | 9 | 0.10 | 207.9 | 6TCF330M9L | 2500 | | | | | |
| | | | | | | | | 7.3 | 4.3 | | 2.8 | | 4400 | 10 | 0.10 | 296.1 | 6TCF470MAH | 2000 | | | | | |
| | | | | | | | | 7.3 | 4.3 | | 3.8 | | 4400 | 10 | 0.10 | 296.1 | 6TCF470MAH | 2000 | | | | | |
| 10 | 105 | 8.0 | 125 | 150 | 7.3 | 4.3 | | 2.8 | D3L | 3600 | 15 | | 0.10 | 150.0 | 10TCF150ML | 2500 | | | | | | | |

*1: Ripple current (100 kHz / +45 °C)

*2: ESR (100 kHz / +20 °C)

*3: tan δ (120 Hz / +20 °C)

*4: After 5 minutes

NRFND Not recommended for new design

◆ Please refer to each page in this catalog for "Reflow conditions", "Taping specifications" and "Floor life level".

 Some part numbers are not a recommended product.
Not recommended for new design.

Conductive Polymer Tantalum Solid Capacitors Surface Mount Type TDC series

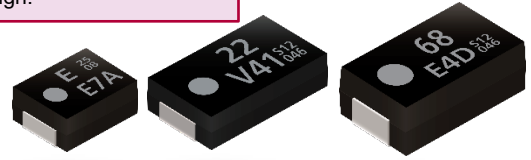

Features

- Guaranteed at 125 °C 1000 h
- High voltage (35 V max.)
- RoHS compliance, Halogen free

Specifications

| Size code | B2 | D2 | D3L |
|-----------------------------|--|--|-----------------|
| Category temp. range | -55 °C to +125 °C | | |
| Rated voltage range | 16 V to 25 V | 16 V to 35 V | 16 V to 25 V |
| Category voltage range | 12.8 V to 20 V | 12.8 V to 28 V | 12.8 V to 20 V |
| Rated capacitance range | 15 µF to 33 µF | 10 µF to 100 µF | 68 µF to 220 µF |
| Capacitance tolerance | ±20 % (120 Hz / +20 °C) | | |
| Leakage current | Please see the attached characteristics list | | |
| Dissipation factor(tan δ) | Please see the attached characteristics list | | |
| Surge voltage (V) | Rated voltage × 1.15 | | |
| Endurance | +125 °C 1000 h, category voltage applied | | |
| | Capacitance change | Within ±20 % of the initial value | |
| | Dissipation factor(tan δ) | ≤ 2 times of the initial limit | |
| | Leakage current | ≤ 2 times of the initial limit | |
| Damp heat (Steady State) | +60 °C, 90 % to 95 % RH, 500 h, No-applied voltage | | |
| | Capacitance change | Within +40 %, -20 % of the initial value | |
| | Dissipation factor(tan δ) | ≤ 1.5 times of the initial limit | |
| | Leakage current | ≤ 3 times of the initial limit | |

Marking

〈 Laser marking (B size) 〉

〈 Laser marking (D size) 〉

〈 Other than the above 〉

| R. voltage code (B size) | | (D size) | | Unit : V | |
|--------------------------|----|----------|----|----------------|----|
| C | 16 | E | 25 | E ¹ | 25 |
| D | 20 | D | 20 | 1E | |
| | | | | V | 35 |

*1:Laser marking

| R. capacitance code (B size) | | Unit : µF | |
|------------------------------|----|-----------|----|
| E7 | 15 | J7 | 22 |
| | | N7 | 33 |

Dimensions (not to scale)

| Size code | L | W±0.2 | H | S±0.2 | W1±0.1 |
|-----------|---------|-------|---------|-------|--------|
| B2 | 3.5±0.2 | 2.8 | 1.9±0.1 | 0.8 | 2.2 |
| D2 | 7.3±0.2 | 4.3 | 1.9±0.1 | 1.3 | 2.4 |
| D3L | 7.3±0.3 | 4.3 | 2.8±0.2 | 1.3 | 2.4 |

Unit : mm

* Externals of figure are the reference.

Characteristics list

| Rated voltage (V) | Rated temperature (°C) | Category voltage (V) | Category temperature (°C) | Rated capacitance (μF) | Case size (mm) | | | Size code | Specifications | | | | Standard | | Floor life level | Re-flow soldering |
|-------------------|------------------------|----------------------|---------------------------|------------------------|----------------|-----|-----|-----------|-------------------------|-----------------------------|---------------------|-----------------------|-------------|---------------------------|------------------|-------------------|
| | | | | | L | W | H | | Ripple current (mA rms) | ESR ^{*2} (mΩ max.) | tan δ ^{*3} | LC ^{*4} (μA) | Part number | Min. packaging q'ty (pcs) | | |
| 16 | 105 | 12.8 | 125 | 33 | 3.5 | 2.8 | 1.9 | B2 | 1000 | 90 | 0.10 | 158.4 | 16TDC33MB2 | 2000 | 3 | A |
| | NEW 105 | 12.8 | 125 | 47 | 7.3 | 4.3 | 1.9 | D2 | 1450 | 55 | 0.10 | 75.2 | 16TDC47MD2 | 3000 | | |
| | NEW 105 | 12.8 | 125 | | 7.3 | 4.3 | 1.9 | | 1250 | 70 | 0.10 | 75.2 | 16TDC47MBD2 | 3000 | | |
| | NEW 105 | 12.8 | 125 | 68 | 7.3 | 4.3 | 1.9 | D3L | 1500 | 50 | 0.10 | 108.8 | 16TDC68MD2 | 3000 | | |
| | NEW 105 | 12.8 | 125 | 100 | 7.3 | 4.3 | 1.9 | | 1800 | 50 | 0.10 | 160.0 | 16TDC100MD2 | 3000 | | |
| | 105 | 12.8 | 125 | 150 | 7.3 | 4.3 | 2.8 | | 1800 | 50 | 0.10 | 240.0 | 16TDC150MD3 | 2500 | | |
| 105 | 12.8 | 125 | 220 | 7.3 | 4.3 | 2.8 | D3L | 1750 | 50 | 0.10 | 352.0 | 16TDC220MD3 | 2500 | C | | |
| 20 | 105 | 16 | 125 | 22 | 3.5 | 2.8 | 1.9 | B2 | 1000 | 90 | 0.10 | 132.0 | 20TDC22MB2 | 2000 | 3 | A |
| | NEW 105 | 16 | 125 | 33 | 7.3 | 4.3 | 1.9 | D2 | 1400 | 60 | 0.10 | 66.0 | 20TDC33MD2 | 3000 | | |
| | NEW 105 | 16 | 125 | 47 | 7.3 | 4.3 | 1.9 | | 1450 | 55 | 0.10 | 94.0 | 20TDC47MD2 | 3000 | | |
| | 105 | 16 | 125 | 100 | 7.3 | 4.3 | 2.8 | D3L | 1700 | 55 | 0.10 | 200.0 | 20TDC100MD3 | 2500 | B | |
| 25 | 105 | 20 | 125 | 15 | 3.5 | 2.8 | 1.9 | B2 | 900 | 100 | 0.10 | 112.5 | 25TDC15MB | 2000 | 3 | A |
| | NEW 105 | 20 | 125 | | 7.3 | 4.3 | 1.9 | D2 | 1000 | 90 | 0.10 | 37.5 | 25TDC15MD2 | 3000 | | |
| | NEW 105 | 20 | 125 | 22 | 7.3 | 4.3 | 1.9 | | 1400 | 60 | 0.10 | 55.0 | 25TDC22MD2 | 3000 | | |
| | NEW 105 | 20 | 125 | 33 | 7.3 | 4.3 | 1.9 | | 1400 | 60 | 0.10 | 82.5 | 25TDC33MD2 | 3000 | | |
| | 105 | 20 | 125 | 68 | 7.3 | 4.3 | 2.8 | D3L | 1400 | 70 | 0.10 | 170.0 | 25TDC68MD3 | 2500 | | |
| | 105 | 20 | 125 | 100 | 7.3 | 4.3 | 2.8 | | 1600 | 60 | 0.10 | 250.0 | 25TDC100MD3 | 2500 | | |
| 35 | NEW 105 | 28 | 125 | 10 | 7.3 | 4.3 | 1.9 | D2 | 820 | 180 | 0.10 | 35.0 | 35TDC10MD2 | 3000 | 3 | A |
| | NEW 105 | 28 | 125 | 15 | 7.3 | 4.3 | 1.9 | | 900 | 150 | 0.10 | 52.5 | 35TDC15MD2 | 3000 | | |
| | NEW 105 | 28 | 125 | 22 | 7.3 | 4.3 | 1.9 | | 900 | 150 | 0.10 | 77.0 | 35TDC22MD2 | 3000 | | |

NRFND [Not recommended for new design]

| | | | | | | | | | | | | | | | | |
|----|-----|------|-----|-----|-----|-----|-----|-----|------|-----|------|-------|-------------|------|---|---|
| 16 | 105 | 12.8 | 125 | 33 | 3.5 | 2.8 | 1.9 | B2 | 1000 | 90 | 0.10 | 158.4 | 16TDC33MYFB | 2000 | 3 | D |
| | 105 | 12.8 | 125 | 100 | 7.3 | 4.3 | 1.9 | D2 | 1800 | 50 | 0.10 | 160.0 | 16TDC100MYF | 3000 | | |
| | 105 | 12.8 | 125 | 150 | 7.3 | 4.3 | 2.8 | D3L | 1800 | 50 | 0.10 | 240.0 | 16TDC150MYF | 2500 | | |
| 20 | 105 | 12.8 | 125 | 22 | 3.5 | 2.8 | 1.9 | B2 | 1000 | 90 | 0.10 | 132.0 | 20TDC22MYFB | 2000 | 3 | D |
| | 105 | 12.8 | 125 | 100 | 7.3 | 4.3 | 2.8 | D3L | 1700 | 55 | 0.10 | 200.0 | 20TDC100MYF | 2500 | | |
| 25 | 105 | 12.8 | 125 | 15 | 3.5 | 2.8 | 1.9 | B2 | 900 | 100 | 0.10 | 112.5 | 25TDC15MYFB | 2000 | 3 | D |
| | 105 | 12.8 | 125 | 68 | 7.3 | 4.3 | 2.8 | D3L | 1400 | 70 | 0.10 | 170.0 | 25TDC68MYF | 2500 | | |

*1: Ripple current (100 kHz / +105 °C)

*2: ESR (100 kHz / +20 °C)

*3: tan δ (120 Hz / +20 °C)

*4: After 5 minutes

◆ Please refer to each page in this catalog for "Reflow conditions", "Taping specifications" and "Floor life level".

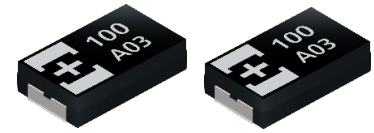

Conductive Polymer Tantalum Solid Capacitors

Surface Mount Type

TPC series

Features

- RoHS compliance, Halogen free

Specifications

| | | |
|-----------------------------|--|--|
| Size code | D2 | |
| Category temp. range | -55 °C to +105 °C | |
| Rated voltage range | 10 V | |
| Category voltage range | 10 V | |
| Rated capacitance range | 68 μF to 100 μF | |
| Capacitance tolerance | ±20 % (120 Hz / +20 °C) | |
| Leakage current | Please see the attached characteristics list | |
| Dissipation factor(tan δ) | Please see the attached characteristics list | |
| Surge voltage (V) | Rated voltage × 1.15 | |
| Endurance | +105 °C 2000 h , rated voltage applied | |
| | Capacitance change | Within ±20 % of the initial value |
| | Dissipation factor(tan δ) | ≤ 1.5 times of the initial limit |
| | Leakage current | Within the initial limit |
| Damp heat (Steady State) | +60 °C, 90 % to 95 % RH, 500 h, No-applied voltage | |
| | Capacitance change | Within +40 %, -20 % of the initial value |
| | Dissipation factor(tan δ) | ≤ 1.5 times of the initial limit |
| | Leakage current | ≤ 3 times of the initial limit |

Marking

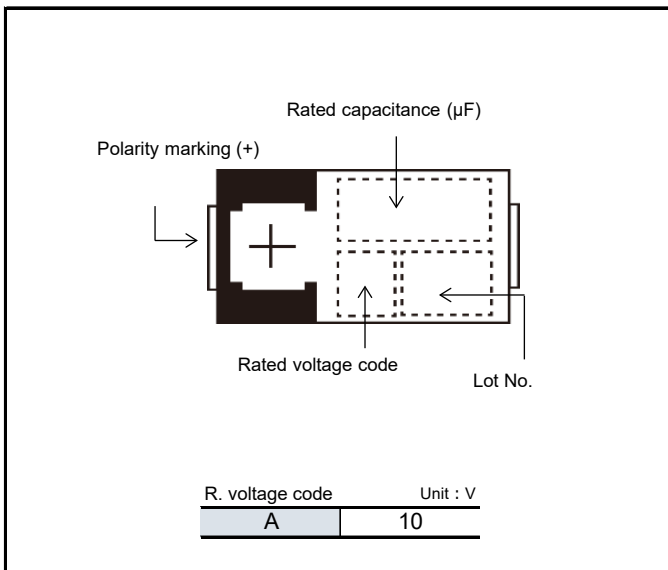

Dimensions (not to scale)

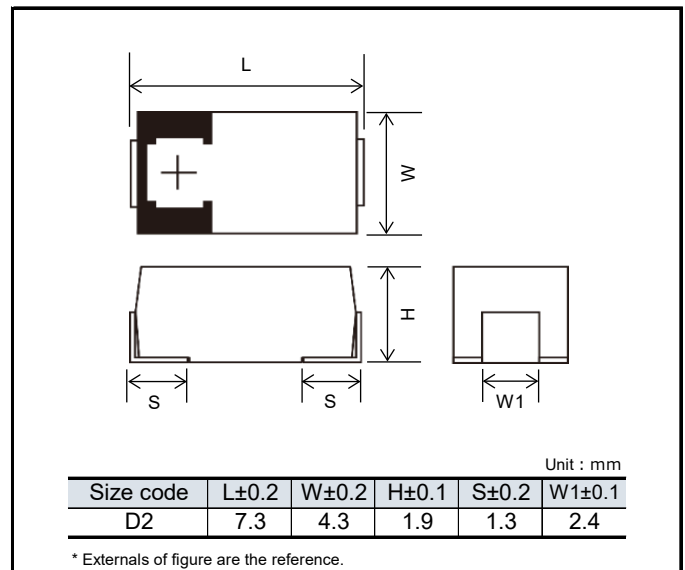

Characteristics list

| Rated voltage (V) | Rated temperature (°C) | Category voltage (V) | Category temperature (°C) | Rated capacitance (µF) | Case size (mm) | | | Size code | Specifications | | | | Standard | | Floor life level | |
|-------------------|------------------------|----------------------|---------------------------|------------------------|----------------|-----|-----|-----------|-------------------------|-----------------------------|---------------------|-----------------------|-------------|---------------------------|--------------------|--------------------|
| | | | | | L | W | H | | Ripple current (mA rms) | ESR ^{*2} (mΩ max.) | tan δ ^{*3} | LC ^{*4} (µA) | Part number | Min. packaging q'ty (pcs) | Reflow temp ≤260°C | Reflow temp ≤250°C |
| 10 | NRFND 105 | 10 | 105 | 68 | 7.3 | 4.3 | 1.9 | D2 | 1700 | 45 | 0.10 | 68.0 | 10TPC68M | 3000 | 3 | 2a |
| | 105 | 10 | 105 | | 7.3 | 4.3 | 1.9 | | 1450 | 60 | 0.10 | 68.0 | 10TPC68MM | 3000 | | |
| | 105 | 10 | 105 | | 7.3 | 4.3 | 1.9 | | 1100 | 100 | 0.10 | 68.0 | 10TPC68ME | 3000 | | |
| | 105 | 10 | 105 | 100 | 7.3 | 4.3 | 1.9 | | 1700 | 45 | 0.10 | 100.0 | 10TPC100M | 3000 | | |
| | 105 | 10 | 105 | | 7.3 | 4.3 | 1.9 | | 1600 | 50 | 0.10 | 100.0 | 10TPC100MT | 3000 | | |
| | 105 | 10 | 105 | | 7.3 | 4.3 | 1.9 | | 1500 | 55 | 0.10 | 100.0 | 10TPC100MG | 3000 | | |

*1: Ripple current (100 kHz / +45 °C)

*2: ESR (100 kHz / +20 °C)

*3: tan δ (120 Hz / +20 °C)

*4: After 5 minutes

NRFND Not recommended for new design

◆ Please refer to each page in this catalog for "Reflow conditions", "Taping specifications" and "Floor life level".

Catalog Deletion Models

The following table is a list of our items which have been deleted from our catalogs.

If you are using any of the following models on the deleted list,

please substitute them with the suggested alternative model as soon as possible.

Our company continue to supply them to customers who have already used them, for the time being.

| Series | Size code | Models for deletion | Year of deletion | Alternative model | Series | Size code | Models for deletion | Year of deletion | Alternative model |
|-----------|-----------|---------------------|------------------|-------------------|--------|-----------|---------------------|------------------|-------------------|
| TPB | B2 | 2R5TPB100M | 2012 | 4TPE100MZB | TQC | C | 16TQC22M | 2011 | 25TQC22MYFD |
| | | 2R5TPB220MA | 2009 | 2R5TPE220MZB | | | 20TQC15M | 2011 | 25TQC15MYFD |
| | | 4TPB100M | 2009 | 4TPE100MZB | | | 25TQC10M | 2011 | 25TQC15MYFD |
| | | 8TPB47M | 2009 | 10TPE47MAZB | | D2 | 16TQC33M | 2012 | 16TQC33MYFD |
| | | 6TPB47M | 2009 | 6TPC47MB | | | 16TQC47M | 2012 | 16TQC47MYFD |
| | | 6TPB100MA | 2009 | 6TPE100MAZB | | | 16TQC68MY | 2012 | 16TQC68MYF |
| | | 6TPB100MAV | 2009 | 6TPE100MAZB | | | 20TQC22M | 2012 | 25TQC22MYFD |
| | D3L | 2R5TPB330ML | 2009 | 2R5TPE330M | | | 20TQC22MYFD | 2015 | 25TQC22MYFD |
| | | 4TPB220ML | 2009 | 4TPE220M | | | 20TQC47MY | 2012 | 20TQC47MYF |
| | | 4TPB470ML | 2009 | 4TPE470ML | | | 25TQC15M | 2012 | 25TQC15MYFD |
| | | 6TPB150ML | 2009 | 6TPE150M | | 25TQC22M | 2012 | 25TQC22MYFD | |
| | | 10TPB100ML | 2010 | 10TPC100M | | D3L | 16TQC68M | 2012 | 16TQC68MYF |
| | D3 | 4TPB220M | 2008 | 4TPE220M | | | 20TQC47M | 2012 | 20TQC47MYF |
| | | 6TPB150M | 2008 | 6TPE150M | | | 25TQC33M | 2012 | 25TQC33MYF |
| | | 10TPB100M | 2008 | 10TPC100M | | D3 | 16TQC100M | 2012 | 16TQC100MYF |
| | D4 | 2R5TPB680M | 2009 | 2R5TPE680MFL | | | | | |
| | | 2R5TPB1000M | 2009 | 2R5TPE1000MF | | | | | |
| | | 4TPB470M | 2009 | 4TPE470ML | | | | | |
| | | 4TPB680M | 2009 | 6TPE680MI | | | | | |
| | TPC | B1 | 2R5TPC56M | 2012 | | 6TPB68M | | | |
| 4TPC47M | | | 2012 | 6TPC47MB | | | | | |
| 6TPC33M | | | 2012 | 6TPC47MB | | | | | |
| 10TPC33MB | | | 2013 | 16TQC33MYFB | | | | | |
| D2 | | 2R5TPC330M | 2009 | 2R5TPE330M | | | | | |
| | | 4TPC150M | 2009 | 4TPE150MI | | | | | |
| | | 4TPC220M | 2009 | 4TPE220M | | | | | |
| TPE | B2 | 2TPE330MIB | 2011 | ETPE330MFB | | | | | |
| | | 2TPE330MAFGB | 2011 | ETPE330MFB | | | | | |
| | | 2R5TPE150MZB | 2011 | 2R5TPE220MZB | | | | | |
| | | 2R5TPE220MIB | 2012 | 2R5TPE220MFGB | | | | | |
| | | 4TPE150MUB | 2013 | 4TPE150MAZB | | | | | |
| | D2E | 2R5TPE220MC | 2012 | 2R5TPE220M9 | | | | | |
| | | 2R5TPE220M7 | 2012 | 2R5TPE330M7 | | | | | |
| | | 2R5TPE470M | 2011 | 2R5TPE470MI | | | | | |
| | | 4TPE150M | 2011 | 4TPE150MI | | | | | |
| | D3L | 2R5TPE680ML | 2012 | 2R5TPE680MFL | | | | | |
| | | 2R5TPE680MIL | 2011 | 2R5TPE680MFL | | | | | |
| | D4 | 2R5TPE1000M | 2011 | 2R5TPE1000MF | | | | | |
| | | 2R5TPE1000MI | 2012 | 2R5TPE1000MF | | | | | |
| | | 4TPE680M | 2011 | 6TPE680MI | | | | | |
| | | 4TPE680MI | 2012 | 6TPE680MI | | | | | |
| 4TPE680MF | | 2012 | 4TPF680MAH | | | | | | |
| TPSF | B2S | 11TPSF62MAIG | 2012 | - | | | | | |
| TH | D2 | 4THC220M | 2013 | 4THE220M | | | | | |
| | D3L | 2R5THB330ML | 2010 | - | | | | | |
| | | 10THB100ML | 2010 | - | | | | | |
| | D4 | 4THB680M | 2013 | - | | | | | |

EOL Models

The following table is a list of the End-Of-Life (EOL) models.

Sales of these items will end as soon as we run out of its stock. We would like to express our appreciation for your business over the years with these products and we hope the new, alternative parts will continue to serve your needs. Thank you very much.

| Series | Size code | Models for deletion | Year of deletion | Alternative model | Series | Size code | Models for deletion | Year of deletion | Alternative model | |
|-----------|-------------|---------------------|------------------|-------------------|--------------|--------------|---------------------|------------------|-------------------|---|
| TPA | C | 6TPA47M | 2012/9 | 10TPB47M | TPE | C2 | 2R5TPE330MFC2 | 2012/9 | 2R5TPE330MF | |
| | | 10TPA33M | 2012/9 | 10TPB33M | | | 2R5TPE330MIC2 | 2012/9 | 2R5TPE330MF | |
| | 4TPA220M | 2012/9 | 4TPE220M | 2R5TPE330MCC2 | | | 2012/9 | 2R5TPE330MC | | |
| | 6TPA150M | 2012/9 | 6TPE150M | 2R5TPE330M9C2 | | | 2012/9 | 2R5TPE330M9 | | |
| 10TPA100M | 2012/9 | 10TPC100M | 4TPE220MFC2 | 2012/9 | | | 4TPE220MF | | | |
| B2 | 4TPB100MV | 2012/9 | 4TPE100MZB | 4TPE220MIC2 | | | 2012/9 | 4TPE220MI | | |
| | 4TPB150MA | 2012/9 | 4TPE150MAZB | 4TPE220MPC2 | | | 2012/9 | 4TPE220MI | | |
| | 8TPB33M | 2012/9 | 10TPB33M | 6TPE150MIC2 | | | 2012/9 | 6TPE150MI | | |
| | 2R5TPB220MC | 2012/9 | 4TPE220MI | 6TPE150MPC2 | | 2012/9 | 6TPE150M | | | |
| | 4TPB150MC | 2012/9 | 6TPE150M | 8TPE100MPC2 | | 2012/9 | 10TPF150ML | | | |
| | 4TPB220MC | 2012/9 | 4TPE220MI | 2R5TPE330MFC | | 2012/9 | 2R5TPE330MF | | | |
| C | 6TPB100MC | 2012/9 | 6TPS150MUD | 2R5TPE330MIC | | 2012/9 | 2R5TPE330MF | | | |
| | 6TPB150MC | 2012/9 | 6TPE150M | 2R5TPE330MPC | | 2012/9 | 2R5TPE330MF | | | |
| | 8TPB82MC | 2012/9 | 8TPE100MAZB | 4TPE220MIC | | 2012/9 | 4TPE220MI | | | |
| | 10TPB47MC | 2012/9 | 10TPC68M | 4TPE220MPC | | 2012/9 | 4TPE220MI | | | |
| | 10TPB68MC | 2012/9 | 10TPC68M | 6TPE150MPC | | 2012/9 | 6TPE150M | | | |
| | 10TPB220MC | 2009/10 | — | 6TPE220MIC | 2012/9 | 6TPE220MI | | | | |
| D3L | 2R5TPB470ML | 2012/9 | 2R5TPE470MI | 6TPE220MPC | 2012/9 | 6TPE220M | | | | |
| | 2R5TPB680ML | 2012/9 | 2R5TPE680MFL | 10TPE150MGC | 2012/9 | 10TPE220ML | | | | |
| | 16TPB47ML | 2003/6 | 16TQC47MYFD | 10TPE180MGC | 2012/9 | 10TPE220ML | | | | |
| | 2R5TPB330M | 2012/9 | 2R5TPE330MI | 6TPE470MAZU | 2024 | 6TPE470M | | | | |
| D3 | 16TPB47M | 2003/6 | 16TQC47MYFD | 2TPE330M6 | 2011 | ETPSF270M6E | | | | |
| | 2R5TPC82M | 2012/9 | — | 2TPE330M7 | 2011 | 2R5TPE330M7 | | | | |
| TPB | C1 | 4TPC56M | 2012/9 | — | 2TPE330M9 | 2011 | 2R5TPE330M9 | | | |
| | | 4TPC100M | 2012/9 | 6TPS150MUD | 2TPE470M6 | 2011 | 2R5TPF470M6L | | | |
| | | 6TPC68M | 2012/9 | 6TPS150MUD | 2TPE470M7 | 2011 | 2R5TPE470M7 | | | |
| | | 6TPC100MC | 2012/9 | 6TPS150MUD | 2TPE470M9 | 2011 | 2R5TPE470M9 | | | |
| | B1 | 8TPC33M | 2012/9 | 16TQC33MYFB | 6TPE330MAL | 2021 | 6TPE330ML | | | |
| | | 6TPC47M | 2024 | 10TPE47MAZB | 2TPF470M6 | 2012/9 | 2R5TPF470M6L | | | |
| | | 6TPC47MB | 2024 | 10TPE47MAZB | 2TPF220M6 | 2024 | ETPSF270M6E | | | |
| | | 8TPC22M | 2024 | 20TQC22MYFB | 2TPF330M6 | 2024 | ETPSF270M6E | | | |
| | | 8TPC150M | 2024 | 10TPE150MPL | 2R5TPF330M7L | 2023 | 2R5TPF470M7L | | | |
| | | 12TPC10M | 2024 | 35TQC10MYFB | 4TPF470M5EL | 2014 | — | | | |
| | D2 | 12TPC15M | 2024 | 16TQC15M | 6TPF330M5EL | 2014 | — | | | |
| | | 2R5TPC220M | 2012/9 | 2R5TPE220MI | 4TPG150M | 2012/9 | 6TPS150MUD | | | |
| | | 16TPC33M | 2003/6 | 16TQC33MYFD | 6TPG68MG | 2012/9 | 6TPS150MUD | | | |
| | | 6TPC100M | 2024 | 6TPE100MW | 2R5TPG220M | 2021 | ETPS220MUD | | | |
| | | 6TPC150M | 2024 | 6TPE150M | 6TPG100M | 2021 | 6TPS150MUD | | | |
| | | 6TPC330MA | 2024 | 6TPE330MAP | 6TPG100MG | 2021 | 6TPS150MUD | | | |
| TPC | C1 | 2R5TPD470M | 2007/10 | 2R5TPF470ML | 6TPG100MZGD | 2021 | 6TPS150MUD | | | |
| | | 2R5TPD470M5 | 2012/3 | ETPF470M5H | 8TPG47M | 2021 | 10TPE47MAZB | | | |
| | | 2R5TPD470M6 | 2012/3 | 2R5TPF470M6L | 10TPG33M | 2011 | 16TQC33MYFB | | | |
| | | 2R5TPD470M8 | 2007/10 | 2R5TPF470M7L | 10TPG47M | 2024 | 10TPE47MAZB | | | |
| | B1 | 2R5TPD680M | 2007/10 | 2R5TPF680ML | 12TPG33M | 2024 | 16TQC33MYFB | | | |
| | | 2R5TPD680M5 | 2012/3 | 2R5TPF680M6L | 6TPG220MZG | 2014 | — | | | |
| | | 2R5TPD680M6 | 2012/3 | 2R5TPF680M6L | 2R5TPG220MUG | 2021 | ETPS220MUD | | | |
| | | 2R5TPD680M8 | 2007/10 | 2R5TPF680M7L | 4TPG220M | 2021 | 4TPS220MUD | | | |
| | | 2R5TPD1000M | 2012/3 | ETPF1000M6H | 6TPG150M | 2021 | 6TPS150MUD | | | |
| | | 2R5TPD1000M8 | 2012/3 | ETPF1000M6H | 6TPG150MZG | 2021 | 6TPS150MUD | | | |
| | D4D | 2R5TPD1000M6 | 2012/3 | ETPF1000M6H | 2R5TPL220MC | 2012/9 | — | | | |
| | | 2R5TPD1000M5 | 2012/3 | ETPF1000M5H | 2R5TPL330M7 | 2011/7 | — | | | |
| | | 4TPD330M | 2007/10 | 4TPF330ML | All models | 2013 | — | | | |
| | | 4TPD470M | 2007/10 | 4TPF470ML | All models | 2013 | — | | | |
| | | 4TPD680M | 2012/3 | 4TPF680MAH | All models | 2013 | — | | | |
| | | 6TPD220M | 2007/10 | 6TPF220ML | 2TPLF470M7 | 2012/9 | — | | | |
| TPD | D4D | 6TPD330M | 2007/10 | 6TPF330M9L | 2TPLF560M6 | 2011/7 | — | | | |
| | | 6TPD470M | 2012/3 | 6TPF470MAH | All models | 2013 | — | | | |
| | | 10TPD150M | 2007/10 | 10TPF150ML | 2TPSF270MC | 2012/9 | 2TPSF270M9G | | | |
| | | 2R5TPE220MPB | 2012/9 | 2R5TPE220MLB | 2TPSF270M9 | 2012/9 | 2TPSF270M9G | | | |
| | B2 | 2R5TPE220MDGB | 2013 | 2R5TPE220MFBG | B1S | ETPSF200M9ED | 2014 | — | | |
| | | 2TPE330MFB | 2021 | ETPE330MFB | TR | TR series | — | TA series | | |
| | | 2TPE330MAFB | 2021 | ETPE330MFB | APA | D2A | APA series | 2006/4 | — | |
| | | 2TPE330MADGB | 2021 | ETPE330M9GB | APB | D1 | APB series | 2006/4 | — | |
| | | 6THC150M | 2024 | 6TCE150M | APC | D2 | APC series | 2009/6 | — | |
| | | 2R5THB470ML | 2012/9 | 6TCE470M | APD | D1 | APD series | 2009/6 | — | |
| | TH | D4 | 2R5THB680M | 2012/9 | — | TPU | S08 | 2R5TPU22M | 2012/9 | — |
| | | | 2R5THB1000M | 2012/9 | — | | | 4TPU15M | 2012/9 | — |
| | | D4D | 2R5THD680M | 2012/3 | 2R5TPF680M6L | | | 6TPU10M | 2012/9 | — |
| | | | 4THD470M | 2012/9 | — | | | 2R5TPU22MSI | 2011 | — |
| | TQC | B15 | 6THD330M | 2012/3 | 6TPF330M9L | | 2R5TPU47MSI | 2018 | — | |
| | | | 35TQC2R7MYF | 2016 | — | | ETPU100MSI | 2018 | — | |
| B2 | | 16TQC10M | 2023 | 35TQC10MYFB | 4TPU15MSI | | 2011 | — | | |
| | | 20TQC8R2M | 2023 | 35TQC10MYFB | 4TPU33MSI | | 2011 | — | | |
| | | 25TQC5R6M | 2023 | 35TQC10MYFB | 4TPU68MSI | | 2018 | — | | |
| | | 35TQC3R9MYF | 2023 | 35TQC10MYFB | 6TPU10MSI | | 2018 | — | | |
| D12 | | 16TQC33MYFS | 2024 | 16TQC33MYFD | 6TPU22MSI | | 2018 | — | | |
| | | 16TQC47MV | 2023 | 16TQC47MYFD | 6TPU47MSI | | 2018 | — | | |
| | 25TQC15MV | 2023 | 25TQC15MYFD | 10TPU4R7MSI | 2018 | | — | | | |
| | 25TQC22MV | 2023 | 25TQC22MYFD | 2R5TPU47MSK | 2012/9 | | — | | | |
| TPH | A09 | 35TQC10M | 2024 | 35TQC10MYF | 2R5TPU68MSK | | 2013 | — | | |
| | | ETPH100MHA | 2018 | — | 4TPU33MSK | | 2012/9 | — | | |
| | | 4TPH68MHA | 2018 | — | 4TPU47MSK | 2013 | — | | | |
| | | 6TPH47MHA | 2018 | — | 6TPU22MSK | 2012/9 | — | | | |
| | A14 | 6TPH100MAEA | 2018 | — | 6TPU33MSK | 2013 | — | | | |
| | | ATPH33MAHA | 2018 | — | 2R5TPU100MAI | 2011 | — | | | |
| TQS | B1S | ETPH220MABC | 2018 | — | 4TPU68MAI | 2011 | — | | | |
| | | ETPH220MAZC | 2013 | — | 6TPU47MAI | 2011 | — | | | |
| | 4TPH150MABC | 2018 | — | 10TPU33MAI | 2011 | — | | | | |
| | 6TPH100MABC | 2018 | — | 4TPU68MBI | 2012/9 | — | | | | |
| TA | D2E | 16TQS33MBD | 2020 | — | 6TPU47MBI | 2012/9 | — | | | |
| | | 25TQS10MED | 2020 | — | 6TPU150MBI | 2018 | — | | | |
| TLE | B2 | 35TQS6R8MHD | 2020 | — | 8TPU33MBI | 2012/9 | — | | | |
| | | 10TAE68M | 2023 | 10TVE68M | ETLE330MCCGB | 2024/4 | ETPE330M9GB | | | |
| TPE | C3 | 6TLE100MZB | 2024/4 | 6TPE100MZB | 6TLE100MZB | 2024/4 | 6TPE100MZB | | | |

Conductive Polymer Aluminum Solid Capacitors

OS-CON™



INDEX

| | |
|-----------------------------------|------|
| Application Guidelines (OS-CON) | P90 |
| Line-up / Diagram | P93 |
| Voltage - Capacitance table | P99 |
| Explanation of part numbers | P104 |
| Mounting / Packing specifications | P105 |
| Each series | P108 |

Applications

Main market

Desktop computer



Audio / Visual

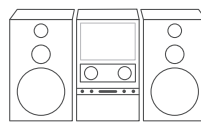

Server



Communications infrastructure

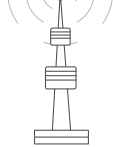

Industrial equipment

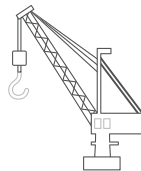

Industrial robot

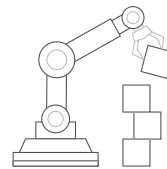

Home appliance



Matters to Be Observed When Using This Product (Conductive Polymer Aluminum Solid Capacitors / OS-CON)

Use environments and cleaning conditions

- This product (capacitor) is intended for standard general-purpose use in electronic equipment, and is not designed for use in the specific environments described below. Using the product in such specific environments or service conditions, therefore, may affect the performance of the product.

Please check with us about the performance and reliability of the product first before using the product.

- (1) Used in liquid, such as water, oil, chemicals, and organic solvents.
- (2) Used in a place exposed to direct sunlight, an outdoor place with no shielding, or a dusty place.
- (3) Used in a wet place (dew concentration on a resistor, water leakage, etc.), a place exposed to sea breeze, or a place filled with a corrosive gas, such as Cl₂, H₂S, NH₃, SO₂, or NO_x.
- (4) Used in an environment where static electricity and electromagnetic waves are strong.
- (5) The product is located close to a heating component or a flammable material, such as a vinyl cable, is placed near the product.
- (6) The product is used sealed with a resin, etc.
- (7) Solder flux of the soldered product is cleansed with a solvent, water, and a water-soluble cleaner.
(Be careful with water soluble solder flux.)
- (8) Used in an environment where an acidic or alkali atmosphere is present.
- (9) Used in an environment where excessive vibration or impact is applied to the product.
- (10) Used under a low atmospheric pressure condition or depressurized condition.

- Cleaning can be performed with cleaning agents, including higher-grade alcohol-based cleaning solutions such as Pine Alpha ST-100S, Cleanthru 750H, 750L, 710M, 750K, Techno Care FRW14-17, CFC substitutes such as AK-225AES, and IPA. Please confirm the following precautions before cleaning.

- (1) Use an immersion, ultrasonic wave, or other cleaning method, and the cleaning time should not exceed 2 minutes.
- (2) The temperature of the cleaning solution should be less than or equal to 60 °C.
- (3) Control contamination of cleaning agents (conductivity, pH, specific gravity, water content, etc.).
- (4) After cleaning, do not store the product in the atmosphere of the cleaning solution or in an airtight container.
- (5) When drying the circuit board or this product, use hot air below the upper limit temperature of their category.
- (6) Please be mindful that rubbing the printed surface of this product after cleaning may erase the markings depending on the cleaning agent used.
- (7) Please contact us separately for details on cleaning agents, cleaning methods, etc., and for cleaning solutions other than those listed above.

- Fixing agents and coating agents

- (1) Select appropriate materials for the outer packaging and sealing materials of this product. Do not use acetone, especially in fixing agents, coating agents, or diluents.
- (2) When using a fixing agent or coating agent, ensure that no flux residue or contamination remains between the circuit board and the sealing area of this product.
- (3) Allow cleaning agents, etc. to dry before using fixing agents or coating agents.
- (4) Please contact us for thermal curing conditions for fixing agents or coating agents.

- When the capacitor is used in a circuit where an impact voltage is applied or a high voltage is applied in a short period (transient phenomenon) or a high pulse voltage is applied, make sure to use the capacitor at a voltage equal to or lower than its rated voltage.

Response to anomalies and handling conditions

- The main failure mode is a short-circuit mode caused mainly by thermal stress, electrical stress, and mechanical stress due to soldering and operating temperature environments. To prevent the occurrence of short circuits, the following measures should be adequately taken to ensure safety.
 - (1) If odorous gases are generated, then turn off the main power of the set equipment and stop using it.
In this case, keep your face and hands away from the equipment.
 - (2) Depending on conditions, it may take several seconds to several minutes before odorous gases are generated.
When using a protection circuit, design it so that it operates during this period.
 - (3) If odorous gases get into your eyes or are inhaled, immediately wash your eyes with water or gargle.
 - (4) Do not lick the electrolyte of the product. If the electrolyte gets on your skin, then wash it off with soap.
 - (5) When a current value after the short of the product is extremely large, the shorted capacitor may spark out, which, in the worst scenario, may result in ignition. Ensure the safety of the circuit by, for example, giving it a redundant circuit structure or providing it with a protective circuit.

Reliability and product life

The failure rate of the capacitor is specified based on 0.5%/1000 h (reliability level 60%), a failure rate conforming to JIS C 5003 (failure rate level). This indicates that the possibility of occurrence of a failure is by no means zero. One of the failure modes is a wear out failure. This happens when the period of guaranteeing the durability and high-temperature/high-humidity resistance of the capacitor is over, changes in the electrical characteristics of the capacitor (product) get larger and its electrolyte gradually deteriorates into an insulating material to create an open mode. Another failure mode is a random failure in which a short mode results mainly because of thermal, electrical, or mechanical stress, etc.

Circuit design and circuit board design

- Due to reasons such as increased leakage currents, do not use this product in high impedance circuits, coupling circuits, time constant circuits, and circuits that are significantly affected by leakage currents.
- During circuit design, be mindful that the electrical characteristics of this product, such as capacitance and ESR, may fluctuate within the specified ranges even under conditions that meet the rated electrical and mechanical performance.
- Leakage currents may increase due to mechanical and thermal stress (soldering, high-temperature no-load test, etc.). However, when the voltage (lower than or equal to the category voltage and upper limit temperature) is applied, leakage currents gradually decrease due to the self-recovery function.
- If an excessive rush current flows due to rapid charging and discharging, then it may lead to short circuits and increased leakage currents. Therefore, apply a protection circuit to this product if the rush current value flowing through it is as follows.
 - (1) When a rush current of 10 A or more flows through a product whose tenfold allowable ripple current is less than 10 A.
 - (2) With regard to a product whose tenfold allowable ripple current is 10 A or more, when a rush current exceeding the tenfold value flows through the product.
- The resin on the surface of the case does not guarantee insulation. In addition, there is an indefinite resistance between the case and the cathode terminal, and they are not insulated. Therefore, completely isolate the case from the cathode terminal, anode terminal, and circuit pattern.

Mounting and storage conditions

- Soldering with a soldering iron
 - (1) Since the lead wire pitch dimension of the radial lead type capacitor and the printed circuit board hole pitch dimension do not match, when processing the lead wires, do not apply stress to the body before soldering.
 - (2) When soldering, do not apply excessive stress to the body of this product.
 - (3) Once the product has been soldered, when using a soldering iron to remove it, remove it after the solder has completely melted so as not to apply stress to the electrode terminals of the product.
 - (4) Do not allow the tip of the soldering iron to touch the body of this product.

■ Flow soldering

- (1) Do not apply flow soldering to the surface mount type model of this product.
- (2) Do not solder this product by immersing its body in molten solder.
- (3) Solder only on the opposite side of the circuit board surface where this product is mounted.
- (4) Do not allow flux to adhere to parts other than the electrode terminals.
- (5) Do not allow other parts to fall over and come into contact with this product during soldering.

■ Reflow soldering

- (1) Do not apply reflow soldering to the radial lead type model of this product.
- (2) Please contact us separately for soldering conditions for using the VPS method.

■ Handling after soldering

Observe the following precautions to avoid applying excessive stress on this product.

- (1) Do not tilt, knock over, or twist this product.
- (2) Do not move the circuit board by grabbing this product.
- (3) Do not hit this product with objects.
- (4) When stacking circuit boards, do not allow circuit boards or other parts to come in contact with this product.

- It is recommended that all components in the bag be used up by opening the bag immediately before use. However, if the remaining components are to be stored after opening the bag, please use them up within the following specified period* to maintain good solderability.

* The surface mount type does not comply with the JEDEC J-STD-020 specification.

- | | |
|---------------------------------------|--|
| (1) Surface mount type | : Within 24 months after shipment (before opening) and within 30 days after opening (packaged with carrier tape) |
| (2) Radial lead type (bagged product) | : Within 30 months after shipment (before opening) and within 7 days after opening |
| (3) Radial lead type (taped product) | : Within 24 months after shipment (before opening) and within 7 days after opening |

Reference information

Intellectual property

Panasonic Group provides customers with safe products and services. We are also making great efforts to protect our intellectual property rights for Panasonic Group products. Typical patents related to this product are as follows.

* No target

Line up

SMD type

| Series | Features | Small size/Low profile | Large cap. | Low ESR | High voltage | Long life/High reliability | Category tem. range (°C) | Rated voltage range (V) | ESR (mΩ) | Rated capacitance range (μF) | Size code | Size (mm) | |
|--------------------|--|------------------------|------------|---------|--------------|----------------------------|--------------------------|-------------------------|----------|------------------------------|-----------|-----------|------|
| | | | | | | | | | | | | øD | L |
| SVT | Low ESR Large capacitnce 125 °C 2000 h | | ● | ● | ● | ● | -55 to 125 | 2.5 to 16 | 15 to 24 | 100 to 820 | C65 | 6.3 | 6.4 |
| | | | | | | | -55 to 125 | 2.5 to 50 | 20 to 35 | 18 to 680 | E7 | 8.0 | 6.9 |
| | | | | | | | -55 to 125 | 16 | 18 | 560 | E10 | 8.0 | 10.0 |
| | | | | | | | -55 to 125 | 2.5 to 50 | 10 to 25 | 39 to 1500 | E12 | 8.0 | 11.9 |
| | | | | | | | -55 to 125 | 16 | 16 | 1000 | F10 | 10.0 | 10.0 |
| | | | | | | | -55 to 125 | 2.5 to 50 | 12 to 20 | 68 to 2700 | F12 | 10.0 | 12.6 |
| SVPT | Low ESR Large capacitnce 105 °C 20000 h | | ● | ● | ● | ● | -55 to 105 | 2.5 to 16 | 15 to 24 | 100 to 820 | C65 | 6.3 | 6.4 |
| | | | | | | | -55 to 105 | 2.5 to 50 | 20 to 35 | 18 to 680 | E7 | 8.0 | 6.9 |
| | | | | | | | -55 to 105 | 16 | 18 | 560 | E10 | 8.0 | 10.0 |
| | | | | | | | -55 to 105 | 2.5 to 50 | 10 to 25 | 39 to 1500 | E12 | 8.0 | 11.9 |
| | | | | | | | -55 to 105 | 16 | 16 | 1000 | F10 | 10.0 | 10.0 |
| | | | | | | | -55 to 105 | 2.5 to 50 | 12 to 20 | 68 to 2700 | F12 | 10.0 | 12.6 |
| SVF | High voltage Large capacitance 125 °C 1000 h | | ● | | ● | ● | -55 to 125 | 16 to 25 | 27 to 40 | 27 to 82 | B6 | 5.0 | 5.9 |
| | | | | | | | -55 to 125 | 16 to 50 | 22 to 40 | 10 to 180 | C6 | 6.3 | 5.9 |
| | | | | | | | -55 to 125 | 16 to 50 | 22 to 35 | 18 to 270 | E7 | 8.0 | 6.9 |
| | | | | | | | -55 to 125 | 16 to 50 | 14 to 25 | 39 to 560 | E12 | 8.0 | 11.9 |
| | | | | | | | -55 to 125 | 16 | 16 | 1000 | F10 | 10.0 | 10.0 |
| | | | | | | | -55 to 125 | 16 to 50 | 12 to 20 | 68 to 1000 | F12 | 10.0 | 12.6 |
| SVPK | High voltage Large capacitance 125 °C 1000 h | | ● | | ● | ● | -55 to 125 | 16 to 50 | 27 to 80 | 10 to 100 | B6 | 5.0 | 5.9 |
| | | | | | | | -55 to 125 | 16 to 50 | 22 to 35 | 22 to 220 | C6 | 6.3 | 5.9 |
| | | | | | | | -55 to 125 | 16 to 50 | 22 to 35 | 33 to 330 | E7 | 8.0 | 6.9 |
| | | | | | | | -55 to 125 | 16 to 50 | 14 to 25 | 68 to 680 | E12 | 8.0 | 11.9 |
| | | | | | | | -55 to 125 | 16 to 50 | 12 to 20 | 120 to 1200 | F12 | 10.0 | 12.6 |
| UPDATE SXV | Super high voltage 125 °C 1000 h | | | | ● | ● | -55 to 125 | 63 to 100 | 60 | 6.8 to 18 | E7 | 8.0 | 6.9 |
| | | | | | | | -55 to 125 | 63 to 100 | 50 to 60 | 15 to 39 | F8 | 10.0 | 7.9 |
| | | | | | | | -55 to 125 | 63 to 100 | 25 to 40 | 15 to 82 | E12 | 8.0 | 11.9 |
| | | | | | | | -55 to 125 | 63 to 100 | 25 to 30 | 18 to 150 | F12 | 10.0 | 12.6 |
| SVPG ^{*1} | Low ESR High ripple current 105 °C 5000 h | | | ● | ● | | -55 to 105 | 16 to 25 | 25 to 30 | 15 to 47 | B45 | 5.0 | 4.4 |
| | | | | | | | -55 to 105 | 16 | 15 | 100 | B6 | 5.0 | 5.9 |
| | | | | | | | -55 to 105 | 16 to 25 | 14 to 18 | 82 to 220 | C6 | 6.3 | 5.9 |
| | | | | | | | -55 to 105 | 16 to 25 | 10 to 14 | 120 to 270 | C8 | 6.3 | 7.9 |
| | | | | | | | -55 to 105 | 16 to 25 | 8 to 13 | 150 to 270 | C10 | 6.3 | 9.9 |
| | | | | | | | -55 to 105 | 16 | 6.5 | 330 | C10L | 6.3 | 10.4 |
| | | | | | | | -55 to 105 | 16 to 25 | 16 to 18 | 120 to 330 | E7 | 8.0 | 6.9 |
| | | | | | | | -55 to 105 | 16 | 10 | 560 | E10 | 8.0 | 10.0 |
| | | | | | | | -55 to 105 | 16 to 25 | 8 to 12 | 270 to 680 | E12 | 8.0 | 11.9 |
| | | | | | | | -55 to 105 | 16 | 9 | 820 | F10 | 10.0 | 10.0 |
| SVPF | High voltage Large capacitance 105 °C 5000 h | | ● | | ● | ● | -55 to 105 | 16 to 25 | 27 to 40 | 27 to 82 | B6 | 5.0 | 5.9 |
| | | | | | | | -55 to 105 | 16 to 50 | 22 to 40 | 10 to 180 | C6 | 6.3 | 5.9 |
| | | | | | | | -55 to 105 | 16 to 50 | 22 to 35 | 18 to 270 | E7 | 8.0 | 6.9 |
| | | | | | | | -55 to 105 | 16 | 18 | 560 | E10 | 8.0 | 10.0 |
| | | | | | | | -55 to 105 | 16 to 50 | 14 to 25 | 39 to 560 | E12 | 8.0 | 11.9 |
| | | | | | | | -55 to 105 | 16 | 16 | 1000 | F10 | 10.0 | 10.0 |
| | | | | | | | -55 to 105 | 16 to 50 | 12 to 20 | 68 to 1000 | F12 | 10.0 | 12.6 |

*1: Some part numbers are not a recommended product

Line up

SMD type

| Series | Features | Small size/Low profile | Large cap. | Low ESR | High voltage | Long life/High reliability | Category tem. range (°C) | Rated voltage range (V) | ESR (mΩ) | Rated capacitance range (μF) | Size code | Size (mm) | |
|--------------------|--|------------------------|-------------|---------|--------------|----------------------------|--------------------------|-------------------------|------------|------------------------------|-----------|-----------|------|
| | | | | | | | | | | | | øD | L |
| SVPA ^{*1} | Low ESR High ripple current | | | ● | | | -55 to 105 | 2.5 to 20 | 30 to 40 | 10 to 82 | B6 | 5.0 | 5.9 |
| | | | | | | | -55 to 105 | 2.5 to 20 | 20 to 35 | 22 to 180 | C6 | 6.3 | 5.9 |
| | | | | | | | -55 to 105 | 2.5 to 20 | 20 to 33 | 47 to 330 | E7 | 8.0 | 6.9 |
| | | | | | | | -55 to 105 | 2.5 to 16 | 19 to 29 | 180 to 820 | F8 | 10.0 | 7.9 |
| SVPC | Low ESR Large capacitance | | ● | ● | | | -55 to 105 | 2.5 to 16 | 19 to 35 | 39 to 180 | B6 | 5.0 | 5.9 |
| | | | | | | | -55 to 105 | 2.5 to 16 | 15 to 30 | 68 to 560 | C6 | 6.3 | 5.9 |
| | | | | | | | -55 to 105 | 2.5 to 16 | 19 to 27 | 120 to 680 | E7 | 8.0 | 6.9 |
| | | | | | | | -55 to 105 | 2.5 to 16 | 9 to 16 | 270 to 1500 | E12 | 8.0 | 11.9 |
| SVPD ^{*1} | Guaranteed at 125°C High voltage 85 °C 85 % RH | | | | ● | ● | -55 to 125 | 10 to 25 | 45 to 65 | 10 to 56 | C6 | 6.3 | 5.9 |
| | | | | | | | -55 to 125 | 16 to 35 | 40 to 70 | 8.2 to 82 | E7 | 8.0 | 6.9 |
| | | | | | | | -55 to 125 | 25 to 35 | 45 to 60 | 18 to 39 | F8 | 10.0 | 7.9 |
| | | | | | | | -55 to 125 | 25 to 35 | 30 to 50 | 22 to 47 | E12 | 8.0 | 11.9 |
| SVPE | Low ESR Large capacitance | | ● | ● | | | -55 to 105 | 2.5 to 6.3 | 10 to 15 | 150 to 390 | B6 | 5.0 | 5.9 |
| | | | | | | | -55 to 105 | 2.5 to 10 | 10 to 20 | 220 to 820 | C6 | 6.3 | 5.9 |
| | | | | | | | -55 to 105 | 2.0 to 16 | 8 to 11 | 180 to 1200 | C10 | 6.3 | 9.9 |
| | | | | | | | -55 to 105 | 16 | 10 | 470 | F12 | 10.0 | 12.6 |
| SVPS ^{*1} | Long life | | | | ● | | -55 to 105 | 4.0 to 10 | 200 to 220 | 10 to 33 | A5 | 4.0 | 5.4 |
| | | | | | | | -55 to 105 | 4.0 to 16 | 30 to 90 | 22 to 68 | B6 | 5.0 | 5.9 |
| | | | | | | | -55 to 105 | 4.0 to 20 | 22 to 60 | 22 to 150 | C6 | 6.3 | 5.9 |
| | | | | | | | -55 to 105 | 4.0 to 25 | 22 to 60 | 10 to 270 | E7 | 8.0 | 6.9 |
| | | | | | | | -55 to 105 | 4.0 to 16 | 20 to 35 | 100 to 680 | F8 | 10.0 | 7.9 |
| SVQP ^{*1} | Guaranteed at 125 °C | | | | ● | | -55 to 105 | 4.0 to 20 | 40 to 60 | 22 to 150 | C6 | 6.3 | 5.9 |
| | | | | | | | -55 to 105 | 6.3 to 20 | 35 to 45 | 47 to 220 | E7 | 8.0 | 6.9 |
| SVP ^{*1} | Standard | | | | | | -55 to 105 | 4.0 to 16 | 200 to 260 | 3.3 to 33 | A5 | 4.0 | 5.4 |
| | | | | | | | -55 to 105 | 4.0 to 20 | 60 to 120 | 10 to 68 | B6 | 5.0 | 5.9 |
| | | | | | | | -55 to 105 | 2.5 to 20 | 23 to 60 | 22 to 220 | C6 | 6.3 | 5.9 |
| | | | | | | | -55 to 105 | 4.0 to 20 | 35 to 45 | 33 to 330 | E7 | 8.0 | 6.9 |
| | | | | | | | -55 to 105 | 4.0 to 20 | 25 to 40 | 56 to 680 | F8 | 10.0 | 7.9 |
| | | | | | | | -55 to 105 | 2.5 to 20 | 13 to 24 | 100 to 680 | E12 | 8.0 | 11.9 |
| -55 to 105 | 2.5 to 20 | 12 to 20 | 150 to 1500 | F12 | 10.0 | 12.6 | | | | | | | |

*1: Some part numbers are not a recommended product

Line up

Radial lead type (Not recommended for new design)

| Series | Features | Small size/Low profile | Large cap. | Low ESR | High voltage | Long life/High reliability | Category tem. range (°C) | Rated voltage range (V) | ESR (mΩ) | Rated capacitance range (μF) | Size code | Size (mm) | |
|--------|--|------------------------|------------|---------|--------------|----------------------------|--------------------------|-------------------------|-----------|------------------------------|-----------|-----------|------|
| | | | | | | | | | | | | øD | L |
| SEF | High voltage Large capacitance 125 °C 1000 h | | ● | | ● | ● | -55 to 125 | 16 to 35 | 22 to 35 | 22 to 180 | C6 | 6.3 | 5.9 |
| | | | | | | | -55 to 125 | 16 to 35 | 22 to 30 | 39 to 270 | E7 | 8.0 | 6.9 |
| | | | | | | | -55 to 125 | 16 to 35 | 14 to 20 | 82 to 560 | E12 | 8.0 | 11.9 |
| | | | | | | | -55 to 125 | 16 to 5 | 12 to 18 | 120 to 1000 | F13 | 8.0 | 12.9 |
| SEK | High voltage Large capacitance 125 °C 1000 h | | ● | | ● | ● | -55 to 125 | 25 to 50 | 25 to 35 | 22 to 82 | C6 | 6.3 | 5.9 |
| | | | | | | | -55 to 125 | 25 to 50 | 24 to 35 | 33 to 120 | E7 | 8.0 | 6.9 |
| | | | | | | | -55 to 125 | 25 to 50 | 16 to 25 | 68 to 270 | E12 | 8.0 | 11.9 |
| | | | | | | | -55 to 125 | 25 to 50 | 14 to 20 | 120 to 470 | F13 | 8.0 | 12.9 |
| SEPG | Low ESR High ripple current 105 °C 5000 h | | | ● | | ● | -55 to 105 | 16 | 12 | 150 | B9 | 5.0 | 8.9 |
| | | | | | | | -55 to 105 | 16 | 10 | 270 | C9 | 10.0 | 8.9 |
| | | | | | | | -55 to 105 | 16 | 8 | 270 | C10 | 6.3 | 9.9 |
| | | | | | | | -55 to 105 | 16 | 8 | 470 | E9 | 8.0 | 8.9 |
| SXE | Super high voltage 125 °C 1000 h | | | | ● | ● | -55 to 125 | 63 to 100 | 60 | 6.8 to 18 | E7 | 8.0 | 6.9 |
| | | | | | | | -55 to 125 | 63 to 100 | 50 to 60 | 15 to 39 | F8 | 8.0 | 7.9 |
| | | | | | | | -55 to 125 | 63 to 100 | 25 to 40 | 15 to 68 | E12 | 8.0 | 11.9 |
| | | | | | | | -55 to 125 | 63 to 100 | 25 to 30 | 18 to 120 | F13 | 8.0 | 12.9 |
| SEPF | Small size Low profile High voltage Large capacitance 105 °C 5000 h | ● | ● | | ● | ● | -55 to 105 | 16 to 32 | 30 to 35 | 22 to 150 | C55 | 6.3 | 5.4 |
| | | | | | | | -55 to 105 | 16 to 35 | 22 to 35 | 22 to 180 | C6 | 6.3 | 5.9 |
| | | | | | | | -55 to 105 | 16 to 35 | 22 to 30 | 39 to 270 | E7 | 8.0 | 6.9 |
| | | | | | | | -55 to 105 | 16 to 35 | 14 to 20 | 82 to 560 | E12 | 8.0 | 11.9 |
| | | | | | | | -55 to 105 | 16 to 35 | 12 to 18 | 120 to 1000 | F13 | 10.0 | 12.9 |
| SEPC | Super low ESR Large capacitance Small size Low profile 105 °C 5000 h | ● | ● | ● | | ● | -55 to 105 | 2.5 | 7 | 100 to 560 | B9 | 5.0 | 8.9 |
| | | | | | | | -55 to 105 | 6.3 | 18 | 220 | C55 | 6.3 | 5.4 |
| | | | | | | | -55 to 105 | 2.5 to 16 | 10 to 24 | 100 to 560 | C6 | 6.3 | 5.9 |
| | | | | | | | -55 to 105 | 2.5 to 16 | 7 to 10 | 100 to 820 | C9 | 6.3 | 8.9 |
| | | | | | | | -55 to 105 | 2.5 to 16 | 8 to 22 | 150 to 1000 | E7 | 8.0 | 6.9 |
| | | | | | | | -55 to 105 | 2.5 to 16 | 5 to 10 | 180 to 1000 | E9 | 8.0 | 8.9 |
| | | | | | | | -55 to 105 | 16 | 11 to 16 | 180 to 270 | E12 | 8.0 | 11.9 |
| | | | | | | | -55 to 105 | 2.5 to 6.3 | 7 to 8 | 470 to 820 | E13 | 8.0 | 12.9 |
| SEQP | 105 °C 5000 h Guaranteed at 125 °C Rated 32 V max. | | | | ● | ● | -55 to 125 | 4.0 to 20 | 40 to 60 | 22 to 150 | C6 | 6.3 | 5.9 |
| | | | | | | | -55 to 125 | 4.0 to 32 | 35 to 100 | 6.8 to 330 | E7 | 8.0 | 6.9 |
| | | | | | | | -55 to 125 | 4.0 to 32 | 25 to 80 | 15 to 680 | F8 | 10.0 | 7.9 |
| | | | | | | | -55 to 125 | 4.0 to 32 | 13 to 50 | 18 to 560 | E12 | 8.0 | 11.9 |
| | | | | | | | -55 to 125 | 4.0 to 20 | 12 to 20 | 150 to 1200 | F13 | 10.0 | 12.9 |
| SEP | Standard | | | | ● | ● | -55 to 105 | 4.0 to 20 | 40 to 60 | 22 to 150 | C6 | 6.3 | 5.9 |
| | | | | | | | -55 to 105 | 4.0 to 20 | 35 to 45 | 33 to 330 | E7 | 8.0 | 6.9 |
| | | | | | | | -55 to 105 | 4.0 to 20 | 25 to 40 | 56 to 680 | F8 | 10.0 | 7.9 |
| | | | | | | | -55 to 105 | 2.5 to 20 | 13 to 24 | 100 to 680 | E12 | 8.0 | 11.9 |
| | | | | | | | -55 to 105 | 2.5 to 20 | 12 to 20 | 150 to 1500 | F12 | 10.0 | 12.9 |

Series flow chart

● SMD type

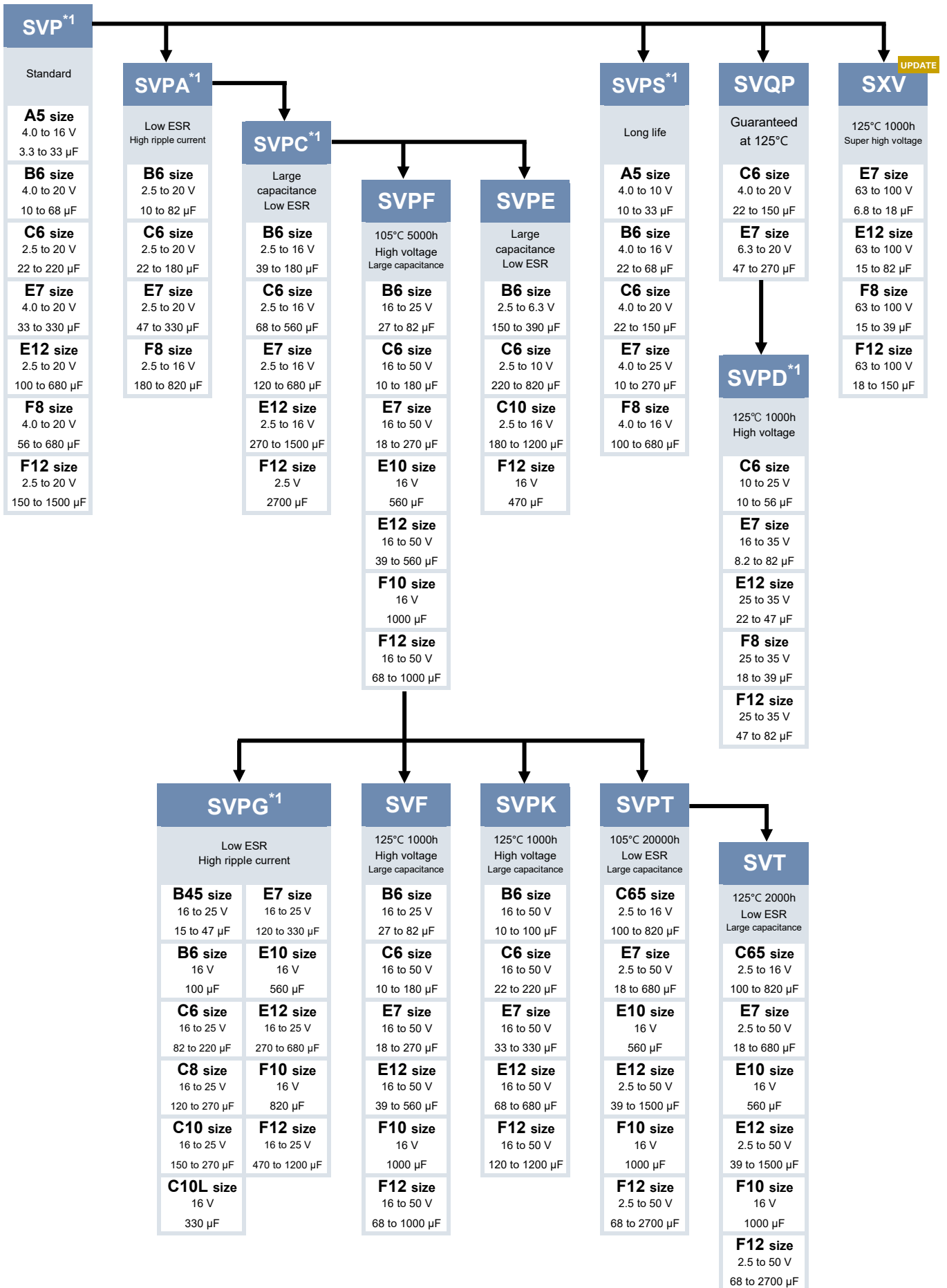

*1: Some part numbers are not a recommended product

Series flow chart

● Radial lead type (Not recommended for new design)

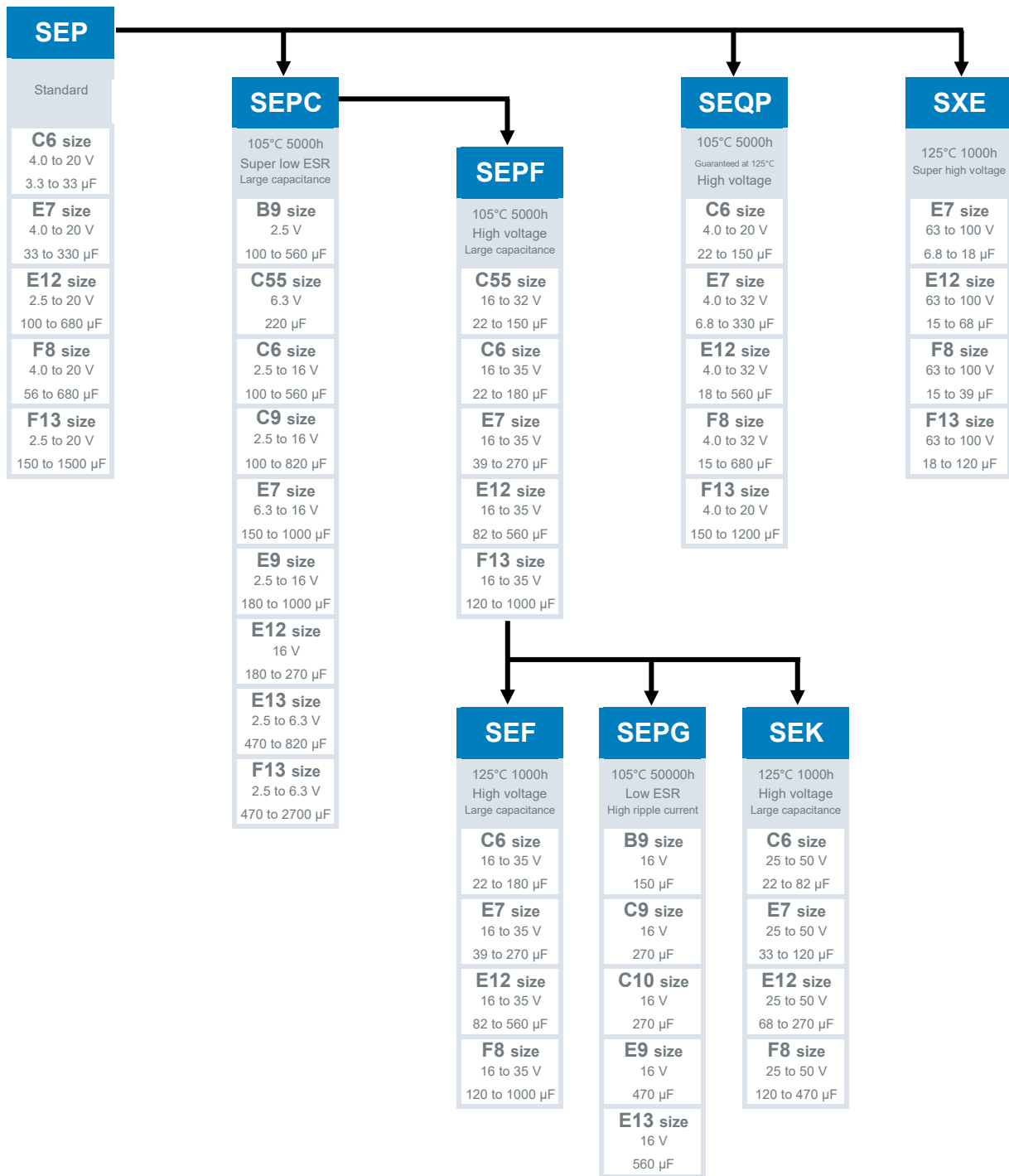

Voltage - Capacitance table (SMD type) (Vol. : 2.0 to 16 V / Cap. : 6.8 to 56 μ F)

Series [Size]
(ESR m Ω)

| V \ μ F | 6.8 | 10 | 12 | 15 | 18 | 22 | 27 | 33 | 39 | 47 | 56 |
|-------------|-----|----|----|----|----|----|-------------------|----|----------------------|--------------------|-------------------|
| 2.0 | | | | | | | | | | | |
| 2.5 | | | | | | | | | | | |
| | | | | | | | | | | | |
| | | | | | | | | | | | |
| 4.0 | | | | | | | | | | | |
| | | | | | | | | | | | |
| | | | | | | | | | | | |
| 6.3 | | | | | | | | | | SVPA [B6] (30) | |
| | | | | | | | | | | SVPS [B6] (30) | |
| | | | | | | | | | | SVP [B6] (70) | |
| | | | | | | | | | | | |
| 10 | | | | | | | | | | SVP [C6] (50) | SVPD [C6] (45) |
| | | | | | | | | | | | SVQP [C6] (45) |
| | | | | | | | | | | | SVP [C6] (45) |
| | | | | | | | | | | | |
| 16 | | | | | | | SVP [B6] (120) | | SVPA [C6] (35,24) | SVPG [B45] (25) | SVP [E7] (45) |
| | | | | | | | | | SVPC [B6] (35,27) | | |
| | | | | | | | | | SVPS [C6] (24) | | |
| | | | | | | | | | SVQP [C6] (50) | | |
| | | | | | | | | | SVP [C6] (50) | | |

Size list ϕ x L (mm)

| | | | | | | | | | | | |
|----|---------|-----|---------|-----|---------|------|----------|-----|----------|-----|-----------|
| A5 | 4.0x5.4 | B45 | 5.0x4.4 | C6 | 6.3x5.9 | C8 | 6.3x7.9 | E7 | 8.0x6.9 | F8 | 10.0x7.9 |
| | | B6 | 5.0x5.9 | C65 | 6.3x6.4 | C10 | 6.3x9.9 | E10 | 8.0x10.0 | F10 | 10.0x10.0 |
| | | | | | | C10L | 6.3x10.4 | E12 | 8.0x11.9 | F12 | 10.0x12.6 |

Voltage - Capacitance table (SMD type) (Vol. : 2.0 to 16 V / Cap. : 68 to 470 μF)

Series [Size]
(ESR mΩ)

| V \ μF | 68 | 82 | 100 | 120 | 150 | 180 | 220 | 270 | 330 | 390 | 470 |
|--------|----------------------|-------------------|----------------------|----------------------|-------------------------|-------------------------|----------------------|--------------------|-------------------------|----------------------|--------------------|
| 2.0 | | | | | | | | | | | |
| 2.5 | | | | | | SVPC [B6] (30,24,19) | SVP [C6] (23) | SVPE [B6] (10) | SVPE [B6] (15,10) | SVPC [C6] (25,15) | |
| | | | | | | | | | | SVPE [B6] (10) | |
| | | | | | | | | | | SVPE [C6] (10) | |
| | | | | | | | | | | | |
| 4.0 | SVPS [B6] (30) | | | | SVPC [B6] (30,23,20) | | | SVPA [E7] (22) | SVPC [C6] (27,21,15) | | |
| | SVP [B6] (60) | | | | SVPS [C6] (22) | | | | SVP [E7] (35) | | |
| | | | | | SVQP [C6] (40) | | | | | | |
| | | | | | SVP [C6] (40) | | | | | | |
| 6.3 | | SVP [C6] (45) | SVPC [B6] (30,25) | SVPA [C6] (22) | SVPE [B6] (12) | | SVPA [E7] (22) | | SVT [C65] (15) | SVT [E7] (22) | SVPA [F8] (20) |
| | | | SVQP [C6] (40) | SVPC [B6] (21) | | | SVPC [C6] (27,15) | | SVPT [C65] (15) | SVPT [E7] (22) | SVPS [F8] (20) |
| | | | SVP [C6] (40) | SVPS [C6] (22) | | | SVPE [B6] (15) | | SVPC [C6] (17) | SVPC [E7] (22) | SVP [E12] (15) |
| | | | | SVP [C6] (17) | | | SVPE [C6] (10) | | SVP [F8] (25) | | SVP [F8] (25) |
| | | | | | | | SVPE [E7] (22) | | | | |
| | | | | | | | SVQP [E7] (35) | | | | |
| 10 | SVPA [C6] (30) | | | SVPC [C6] (27,22) | SVPA [E7] (30) | | SVPE [C6] (20) | SVPC [E7] (22) | SVPA [F8] (24) | | |
| | SVPC [B6] (30,23) | | | SVQP [E7] (35) | SVPS [E7] (30) | | | SVP [F8] (25) | SVPC [E7] (19) | | |
| | SVPS [C6] (30) | | | SVP [E7] (35) | SVPS [F8] (30) | | | | SVPS [F8] (24) | | |
| | | | | | SVQP [E7] (35) | | | | SVP [E12] (17) | | |
| | | | | | SVP [E7] (35) | | | | SVP [F8] (25) | | |
| 16 | SVPC [C6] (30,25) | SVPA [E7] (30) | SVT [C65] (24) | SVPC [E7] (27) | SVPC [E7] (22) | SVPA [F8] (29) | SVPG [C6] (14) | SVT [E7] (22) | SVPG [C10L] (6.5) | | SVPE [F12] (10) |
| | | SVPD [E7] (40) | SVPT [C65] (24) | | SVP [F8] (30) | SVPE [C10] (11) | SVPK [C6] (22) | SVPT [E7] (22) | SVPG [E7] (16) | | |
| | | SVPF [B6] (24) | SVPC [C6] (24) | | | SVPF [C6] (22) | | SVPC [E12] (16) | SVPK [E7] (22) | | |
| | | SVPS [E7] (30) | SVPG [B6] (15) | | | SVPS [F8] (29) | | SVPF [E7] (22) | SVP [F12] (16) | | |
| | | SVQP [E7] (40) | SVPK [B6] (27) | | | SVP [F8] (30) | | SVPG [C8] (10) | | | |
| | | SVP [E7] (40) | SVPS [F8] (35) | | | SVP [E12] (20) | | SVPG [C10] (8) | | | |
| | | SVF [B6] (25) | SVP [F8] (35) | | | SVF [C6] (22) | | SVF [E7] (22) | | | |

Size list ø x L (mm)

| | | | | | | | | | | | |
|----|---------|-----|---------|-----|---------|------|----------|-----|----------|-----|-----------|
| A5 | 4.0x5.4 | B45 | 5.0x4.4 | C6 | 6.3x5.9 | C8 | 6.3x7.9 | E7 | 8.0x6.9 | F8 | 10.0x7.9 |
| | | B6 | 5.0x5.9 | C65 | 6.3x6.4 | C10 | 6.3x9.9 | E10 | 8.0x10.0 | F10 | 10.0x10.0 |
| | | | | | | C10L | 6.3x10.4 | E12 | 8.0x11.9 | F12 | 10.0x12.6 |

Voltage - Capacitance table (SMD type) (Vol. : 2.0 to 16 V / Cap. : 560 to 2700 μF)

Series [Size]
(ESR mΩ)

| V | μF | 560 | 680 | 820 | 1000 | 1200 | 1500 | 2700 |
|-----|----|--------------------|--------------------|--------------------|--------------------|--------------------|--------------------|--------------------|
| 2.0 | | | | | | SVPE [C10] (8) | | |
| | | SVT [C65] (16) | SVT [C65] (16) | SVPA [F8] (19) | | | SVT [E12] (10) | SVT [F12] (12) |
| 2.5 | | SVPT [C65] (16) | SVT [E7] (20) | SVPC [E12] (9) | | | SVPT [E12] (10) | SVPT [F12] (12) |
| | | SVPC [C6] (16) | SVPT [C65] (16) | SVT [C65] (16) | | | SVPC [E12] (10) | SVPC [F12] (12) |
| | | | SVPT [E7] (20) | SVPT [C65] (16) | | | SVP [F12] (12) | |
| | | | SVPC [E7] (20) | | | | | |
| | | | SVP [E12] (13) | | | | | |
| 4.0 | | SVT [E7] (22) | SVPA [F8] (20) | | | SVPC [E12] (12) | SVT [E12] (12) | |
| | | SVPT [E7] (22) | SVPS [F8] (20) | | | SVP [F12] (12) | SVPT [E12] (12) | |
| | | SVPC [E7] (22) | SVP [F8] (25) | | | | SVPC [E12] (12) | |
| | | SVPC [E12] (9) | | | | | | |
| | | SVP [E12] (13) | | | | | | |
| 6.3 | | | | SVT [E12] (12) | | | | |
| | | | | SVPT [E12] (12) | | | | |
| | | | | SVPC [E12] (12) | | | | |
| | | | | SVP [F12] (12) | | | | |
| 10 | | SVP [F12] (13) | | | | | | |
| | | | | | | | | |
| | | | | | | | | |
| | | | | | | | | |
| 16 | | SVT [E10] (18) | SVPG [E12] (8) | SVPG [F10] (9) | SVT [F10] (18) | SVPG [F12] (7) | | |
| | | SVT [E12] (14) | SVPK [E12] (14) | | SVT [F12] (12) | SVPK [F12] (12) | | |
| | | SVPT [E10] (16) | | | SVPT [F10] (16) | | | |
| | | SVPT [E12] (14) | | | SVPT [F12] (12) | | | |
| | | SVPF [E10] (18) | | | SVPF [F10] (16) | | | |
| | | SVPF [E12] (14) | | | SVPF [F12] (12) | | | |
| | | SVPG [E10] (10) | | | SVF [F10] (16) | | | |
| | | SVF [E12] (14) | | | SVF [F12] (12) | | | |

Size list ø x L (mm)

| | | | | | | | | | | | |
|----|---------|-----|---------|-----|---------|------|----------|-----|----------|-----|-----------|
| A5 | 4.0x5.4 | B45 | 5.0x4.4 | C6 | 6.3x5.9 | C8 | 6.3x7.9 | E7 | 8.0x6.9 | F8 | 10.0x7.9 |
| | | B6 | 5.0x5.9 | C65 | 6.3x6.4 | C10 | 6.3x9.9 | E10 | 8.0x10.0 | F10 | 10.0x10.0 |
| | | | | | | C10L | 6.3x10.4 | E12 | 8.0x11.9 | F12 | 10.0x12.6 |

Voltage - Capacitance table (SMD type) (Vol. : 20 to 100 V / Cap. : 6.8 to 56 μF)

Series [Size]
(ESR mΩ)

| V | μF | 6.8 | 10 | 12 | 15 | 18 | 22 | 27 | 33 | 39 | 47 | 56 |
|-----|----|------------------|-------------------|------------------|-------------------|-------------------|--------------------|-------------------|--------------------|--------------------|--------------------|-----------------------|
| 20 | | | SVPA [B6] (40) | | | | SVPA [C6] (35) | SVP [C6] (60) | SVPG [B45] (27) | | SVPA [E7] (33) | SVPF [B6] (30) |
| | | | SVP [B6] (120) | | | | SVPS [C6] (60) | | SVP [E7] (45) | | SVPS [E7] (45) | SVF [F8] (40) |
| | | | | | | | SVQP [C6] (60) | | | | SVQP [E7] (45) | SVF [B6] (30) |
| | | | | | | | SVP [C6] (60) | | | | SVP [E7] (45) | |
| | | | | | | | | | | | | |
| 25 | | | SVPD [C6] (65) | | | | SVPD [E7] (48) | SVPF [B6] (40) | SVPK [B6] (35) | SVPD [F8] (45) | SVPD [E12] (30) | SVPF [C6] (30) |
| | | | SVPS [E7] (60) | | | | | SVF [B6] (40) | | | SVPF [C6] (30) | SVF [C6] (30) |
| | | | | | | | | | | | SVF [C6] (30) | |
| | | | | | | | | | | | | |
| 35 | | | | | | SVPD [F8] (60) | SVPD [E12] (50) | | | | SVT [E7] (30) | SVPD [F12] (30) |
| | | | | | | | SVPF [C6] (35) | | | | SVPT [E7] (30) | SVPK [C6] (27) |
| | | | | | | | SVF [C6] (35) | | | | SVPF [E7] (30) | |
| | | | | | | | SVPK [B6] (35) | | | | SVF [E7] (30) | |
| 50 | | | SVPF [C6] (40) | | | SVT [E7] (35) | SVPK [C6] (35) | | SVPK [E7] (35) | SVT [E12] (25) | | |
| | | | SVF [C6] (40) | | | SVPT [E7] (35) | | | | SVPT [E12] (25) | | |
| | | | SVPK [B6] (80) | | | SVPF [E7] (35) | | | | SVPF [E12] (25) | | |
| | | | | | | SVF [E7] (35) | | | | SVF [E12] (25) | | |
| 63 | | | | | SXV [E7] (60) | | | | SXV [E12] (25) | SXV [E12] (25) | | SXV [E12] (25) |
| | | | | | | | | | | SXV [F8] (50) | | |
| 72 | | | | | | | | | | | | |
| 80 | | | | SXV [E7] (60) | | | | SXV [E12] (35) | SXV [E12] (35) | | SXV [E12] (35) | SXV [E12] (28, 35) |
| | | | | | | | | SXV [F8] (55) | | | SXV [F12] (28) | SXV [F12] (28) |
| 100 | | SXV [E7] (60) | | | SXV [E12] (40) | SXV [E12] (40) | SXV [F12] (30) | SXV [E12] (40) | | | SXV [F12] (30) | |
| | | | | | SXV [F8] (60) | SXV [F12] (30) | | SXV [F12] (30) | | | | |

Size list ø x L (mm)

| | | | | | | | | | | | |
|----|---------|-----|---------|-----|---------|------|----------|-----|----------|-----|-----------|
| A5 | 4.0x5.4 | B45 | 5.0x4.4 | C6 | 6.3x5.9 | C8 | 6.3x7.9 | E7 | 8.0x6.9 | F8 | 10.0x7.9 |
| | | B6 | 5.0x5.9 | C65 | 6.3x6.4 | C10 | 6.3x9.9 | E10 | 8.0x10.0 | F10 | 10.0x10.0 |
| | | | | | | C10L | 6.3x10.4 | E12 | 8.0x11.9 | F12 | 10.0x12.6 |

Voltage - Capacitance table (SMD type) (Vol. : 20 to 100 V / Cap. : 68 to 470 μF)

Series [Size]
(ESR mΩ)

| V | μF | 68 | 82 | 100 | 120 | 150 | 180 | 220 | 270 | 330 | 390 | 470 |
|-----|----|--------------------|--------------------|-------------------|--------------------|--------------------|--------------------|-------------------|--------------------|--------------------|--------------------|--------------------|
| 20 | | SVPK [B6] (30) | | SVP [E12] (24) | SVPF [C6] (25) | SVPK [C6] (25) | SVT [E7] (25) | SVPK [E7] (25) | | | SVT [E12] (14) | SVPK [E12] (14) |
| | | SVP [F8] (40) | | | SVF [C6] (25) | SVP [F12] (20) | SVPT [E7] (25) | SVPG [E7] (18) | | | SVPT [E12] (14) | SVPG [E12] (10) |
| | | | | | SVPG [C6] (18) | | SVPF [E7] (25) | | | | SVPF [E12] (14) | |
| | | | | | | | SVF [E7] (25) | | | | SVF [E12] (14) | |
| | | | | | | | SVPG [C8] (14) | | | | | |
| | | | | | | | SVPG [C10] (11) | | | | | |
| 25 | | | SVPD [F12] (28) | SVT [E7] (24) | SVPK [E7] (24) | SVPG [C10] (13) | SVT [E12] (16) | | SVPK [E12] (16) | SVT [F12] (14) | | SVPK [F12] (14) |
| | | | SVPF [E7] (28) | SVPT [E7] (24) | SVPG [C8] (15) | | SVPT [E12] (16) | | SVPG [E12] (12) | SVPT [F12] (14) | | SVPG [F12] (10) |
| | | | SVPK [C6] (25) | SVPF [E7] (24) | SVPG [E7] (17) | | SVPF [E12] (16) | | | SVPF [F12] (14) | | |
| | | | SVF [E7] (28) | SVF [E7] (24) | | | SVF [E12] (16) | | | SVF [F12] (14) | | |
| | | | SVPG [C6] (18) | | | | | | | | | |
| 35 | | | SVT [E12] (20) | | SVT [F12] (18) | | SVPK [E12] (20) | | | SVPK [F12] (18) | | |
| | | | SVPT [E12] (20) | | SVPT [F12] (18) | | | | | | | |
| | | | SVPF [E12] (20) | | SVPF [F12] (18) | | | | | | | |
| | | | SVF [E12] (20) | | SVF [F12] (18) | | | | | | | |
| | | | SVPK [E7] (25) | | | | | | | | | |
| 50 | | SVT [F12] (20) | | | SVPK [F12] (20) | | | | | | | |
| | | SVPT [F12] (20) | | | | | | | | | | |
| | | SVPF [F12] (20) | | | | | | | | | | |
| | | SVF [F12] (20) | | | | | | | | | | |
| | | SVPK [E12] (25) | | | | | | | | | | |
| 63 | | SXV [E12] (25) | SXV [E12] (25) | SXV [F12] (25) | SXV [F12] (25) | SXV [F12] (25) | | | | | | |
| | | SXV [F12] (25) | | | | | | | | | | |
| 72 | | | SXV [F12] (28) | SXV [F12] (28) | | | | | | | | |
| | | | | | | | | | | | | |
| 80 | | | | SXV [F12] (28) | | | | | | | | |
| | | | | | | | | | | | | |
| 100 | | | | | | | | | | | | |
| | | | | | | | | | | | | |

Size list ø x L (mm)

| | | | | | | | | | | | |
|----|---------|-----|---------|-----|---------|------|----------|-----|----------|-----|-----------|
| A5 | 4.0x5.4 | B45 | 5.0x4.4 | C6 | 6.3x5.9 | C8 | 6.3x7.9 | E7 | 8.0x6.9 | F8 | 10.0x7.9 |
| | | B6 | 5.0x5.9 | C65 | 6.3x6.4 | C10 | 6.3x9.9 | E10 | 8.0x10.0 | F10 | 10.0x10.0 |
| | | | | | | C10L | 6.3x10.4 | E12 | 8.0x11.9 | F12 | 10.0x12.6 |

Voltage - Capacitance table (SMD type) (Vol. : 20 to 100 V / Cap. : 560 to 2700 μ F)

Series [Size]
(ESR m Ω)

| V | μ F | 560 | 680 | 820 | 1000 | 1200 | 1500 | 2700 |
|-----|---------|--------------------|--------------------|-----|------|------|------|------|
| 20 | | SVT [F12] (12) | SVPK [F12] (12) | | | | | |
| | | SVPT [F12] (12) | SVPG [F12] (9) | | | | | |
| | | SVPF [F12] (12) | | | | | | |
| | | SVF [F12] (12) | | | | | | |
| 25 | | | | | | | | |
| | | | | | | | | |
| | | | | | | | | |
| | | | | | | | | |
| 35 | | | | | | | | |
| | | | | | | | | |
| | | | | | | | | |
| | | | | | | | | |
| 50 | | | | | | | | |
| | | | | | | | | |
| | | | | | | | | |
| | | | | | | | | |
| 63 | | | | | | | | |
| | | | | | | | | |
| 72 | | | | | | | | |
| | | | | | | | | |
| 80 | | | | | | | | |
| | | | | | | | | |
| 100 | | | | | | | | |
| | | | | | | | | |

Size list ϕ x L (mm)

| | | | | | | | | | | | |
|----|---------|-----|---------|-----|---------|------|----------|-----|----------|-----|-----------|
| A5 | 4.0x5.4 | B45 | 5.0x4.4 | C6 | 6.3x5.9 | C8 | 6.3x7.9 | E7 | 8.0x6.9 | F8 | 10.0x7.9 |
| | | B6 | 5.0x5.9 | C65 | 6.3x6.4 | C10 | 6.3x9.9 | E10 | 8.0x10.0 | F10 | 10.0x10.0 |
| | | | | | | C10L | 6.3x10.4 | E12 | 8.0x11.9 | F12 | 10.0x12.6 |

Explanation of part numbers

◇ Part number system

• Surface mount type

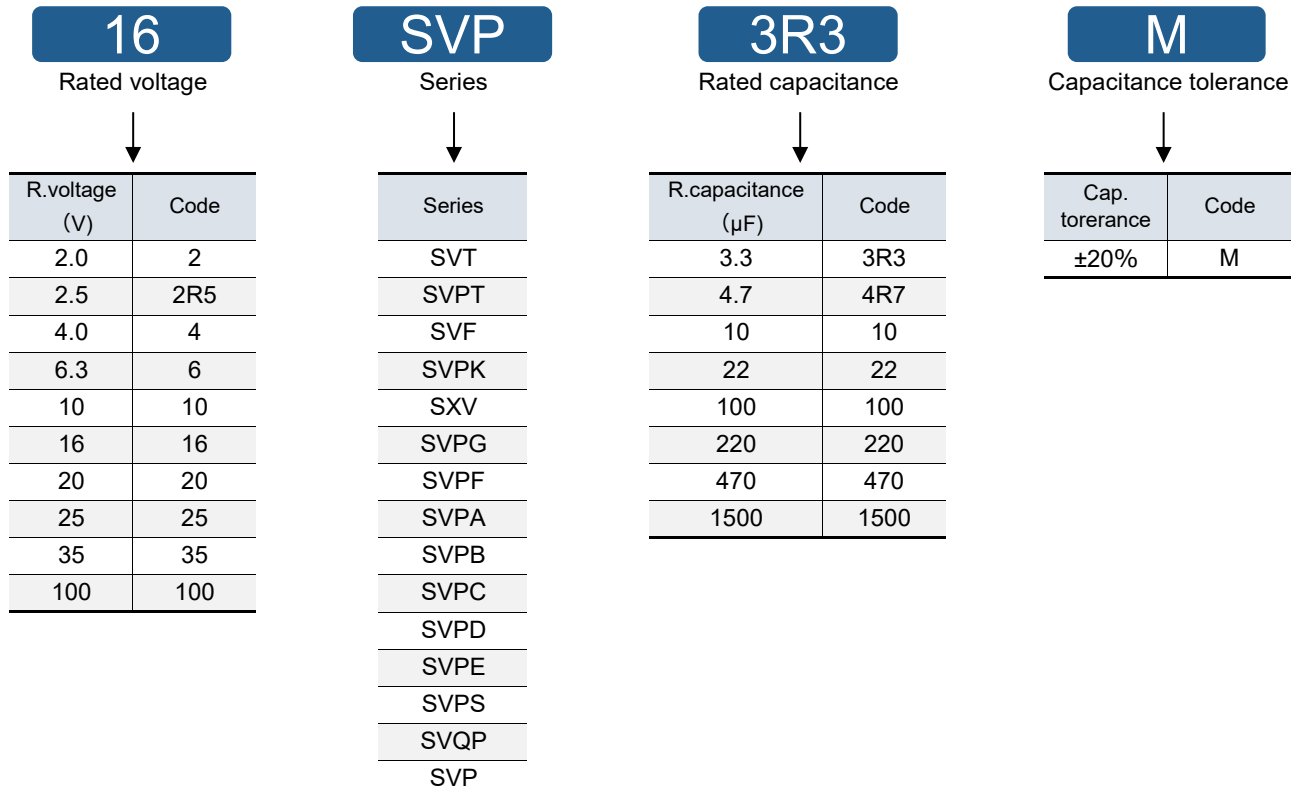

• Radial lead type

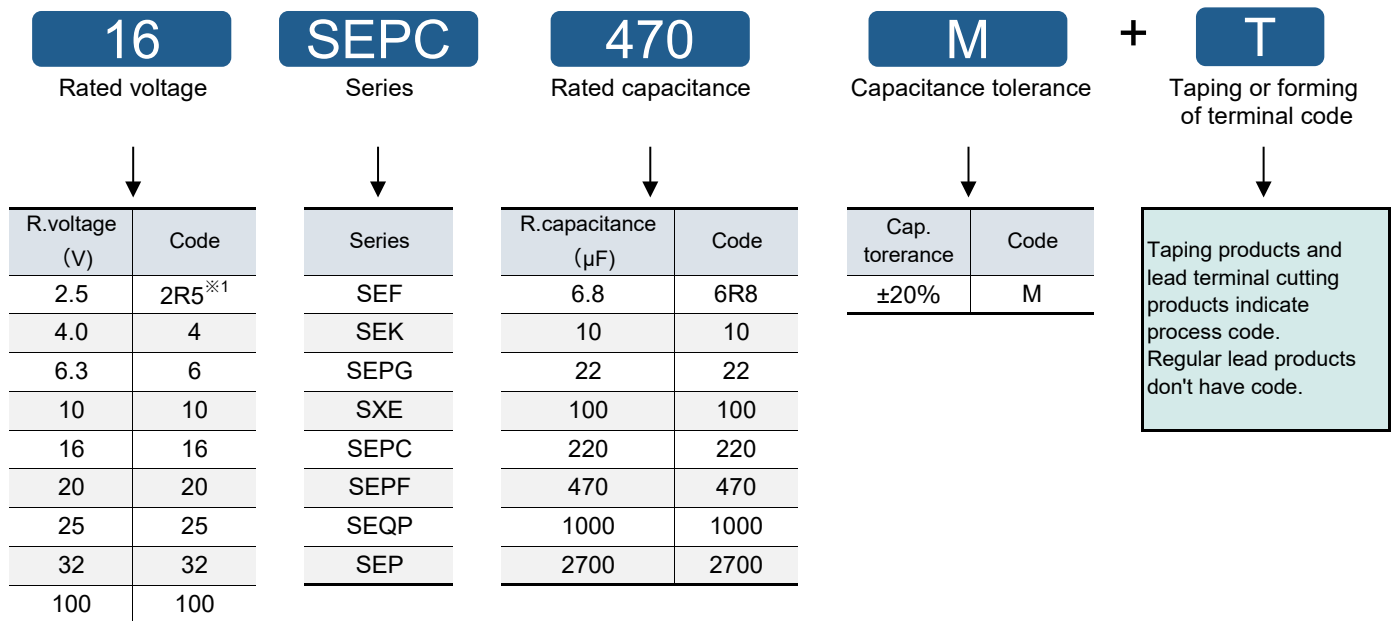

※1 Code 2 is used for 2.5 V products of B9, C6, C9, E7, E9 and F13 size in SEPC series.

Mounting specifications

◇ **Recommendable reflow soldering (SMD type)**

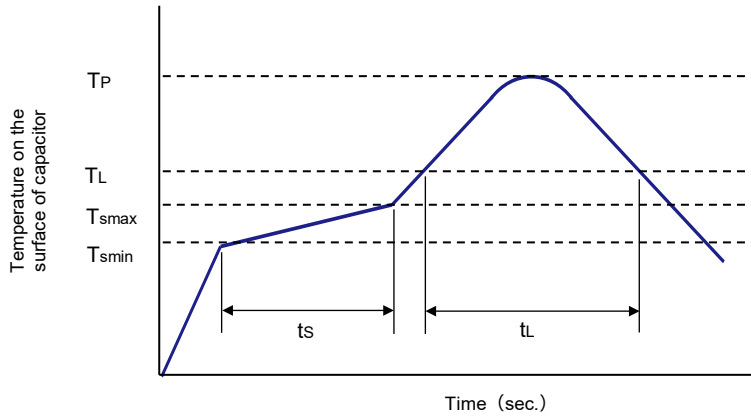

| Reflow soldering | | Condition A | Condition B | Condition C |
|---|-------------------------|--|--|--|
| | | Peak temperature 260 °C lead free soldering profile | Peak temperature 250 °C lead free soldering profile | Peak temperature 250 °C lead free soldering profile (SVPG, SVPF, SVF, SVPK, SXV) |
| Peak temperature (T _P) | | 260 °C | 250 °C | 250 °C |
| Soldering time (t _L) above soldering temperature (T _L) | T _L ≥ 245 °C | - | | 30 seconds max. |
| | T _L ≥ 230 °C | 40 seconds max. | | - |
| | T _L ≥ 220 °C | 50 seconds max. | | - |
| | T _L ≥ 217 °C | - | | 90 seconds max. |
| Preheat | | 180 °C | | 200 °C*1 |
| Temperature max. (T _{smax}) | | 150 °C | | |
| Temperature min. (T _{smin}) | | 120 seconds max. | | |
| Time (t _s) from (T _{smin}) to (T _{smax}) | | | | |
| The cycles of reflow soldering | | 1 times | 2 times | 2 times |

*1 SXV series : 180°C

◇ **Flow soldering (Radial lead type)**

| | Temperature | Time | Flow number |
|---------------------|---|-------------------|-------------------|
| Preheating | 120 °C or less (ambient temperature) | 120 sec. or less | 1 time |
| Soldering condition | 260 °C+5 °C or less | 10+1 sec. or less | 2 times or less*1 |

*1 : When soldering 2 times, total immersion time should be 10+1 sec. or less.

◇ **Soldering with a soldering iron**

Tip of a soldering iron : 400 °C±10 °C
Working time : 5 sec. max.

Land Pattern

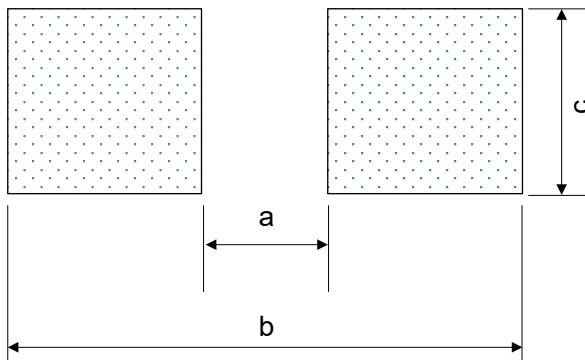

| Size code | Unit : mm | | |
|-----------|-----------|------|-----|
| | a | b | c |
| A5 | 1.0 | 6.2 | 1.6 |
| B45 | 1.4 | 7.4 | 1.6 |
| B6 | 1.4 | 7.4 | 1.6 |
| C6 | 2.1 | 9.1 | 1.6 |
| C65 | 2.1 | 9.1 | 1.6 |
| C8 | 2.1 | 9.1 | 1.6 |
| C10 | 2.1 | 9.1 | 1.6 |
| C10L | 2.1 | 9.1 | 2.5 |
| E7 | 2.8 | 11.1 | 1.9 |
| E10 | 2.8 | 11.1 | 1.9 |
| E12 | 2.8 | 11.1 | 1.9 |
| F8 | 4.3 | 13.1 | 1.9 |
| F10 | 4.3 | 13.1 | 1.9 |
| F12 | 4.3 | 13.1 | 1.9 |

Packing specifications

◇ SMD type

● Taping

1-1. Carrier tape

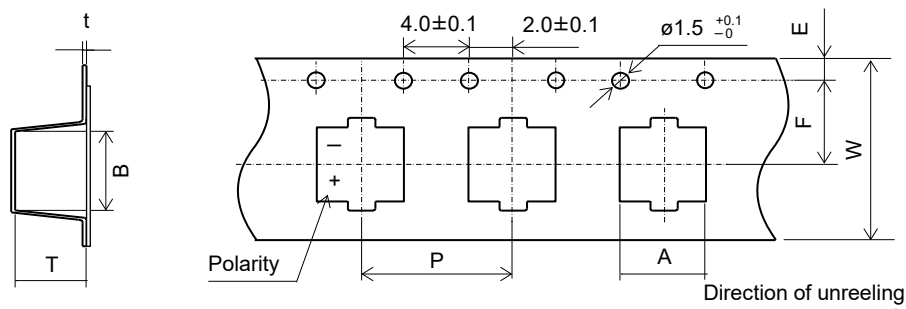

| Size code | A±0.2 | B±0.2 | W±0.3 | F±0.1 | E±0.1 | P±0.1 | t±0.1 | T±0.2 |
|-----------|-------|-------|-------|-------|-------|-------|-------|-------|
| A5 | 4.7 | 4.7 | 12.0 | 5.5 | 1.75 | 8.0 | 0.4 | 5.8 |
| B45 | 5.6 | 5.6 | 16.0 | 7.5 | 1.75 | 8.0 | 0.4 | 4.8 |
| B6 | 5.6 | 5.6 | 16.0 | 7.5 | 1.75 | 8.0 | 0.4 | 6.2 |
| C6 | 6.9 | 6.9 | 16.0 | 7.5 | 1.75 | 12.0 | 0.4 | 6.2 |
| C65 | 6.9 | 6.9 | 16.0 | 7.5 | 1.75 | 12.0 | 0.4 | 6.7 |
| C8 | 7.0 | 7.0 | 16.0 | 7.5 | 1.75 | 12.0 | 0.5 | 8.2 |
| C10 | 7.0 | 7.0 | 24.0 | 11.5 | 1.75 | 16.0 | 0.5 | 10.5 |
| C10L | 7.0 | 7.0 | 16.0 | 7.5 | 1.75 | 12.0 | 0.5 | 11.0 |
| E7 | 8.6 | 8.6 | 24.0 | 11.5 | 1.75 | 12.0 | 0.4 | 7.2 |
| E10 | 8.6 | 8.6 | 24.0 | 11.5 | 1.75 | 16.0 | 0.5 | 11.0 |
| E12 | 8.6 | 8.6 | 24.0 | 11.5 | 1.75 | 16.0 | 0.5 | 12.3 |
| F8 | 10.7 | 10.7 | 24.0 | 11.5 | 1.75 | 16.0 | 0.4 | 8.2 |
| F10 | 10.7 | 10.7 | 24.0 | 11.5 | 1.75 | 16.0 | 0.4 | 11.0 |
| F12 | 10.7 | 10.7 | 24.0 | 11.5 | 1.75 | 16.0 | 0.4 | 13.0 |

1-2. Reel

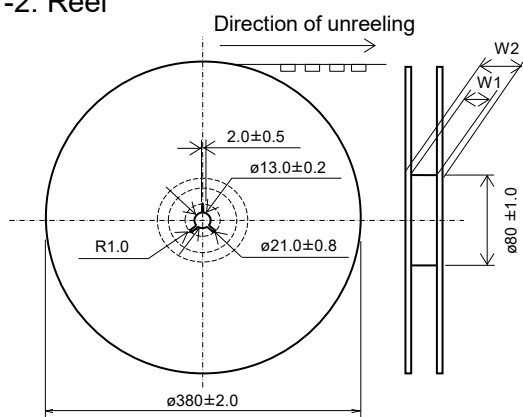

| Size code | W1±0.5 | W2±1.0 |
|---------------------------------|--------|--------|
| A5 | 13.0 | 17.5 |
| B45, B6, C6, C65, C8, C10L | 17.0 | 21.5 |
| C10, E7, E10, E12, F8, F10, F12 | 25.0 | 29.5 |

● Minimum packing quantity and weight

| Size code | Quantity (pcs./Reel, ø380) | Typical weight (g) |
|-----------|----------------------------|--------------------|
| A5 | 2000 | 700 |
| B45 | 2500 | 900 |
| B6 | 1500 | 800 |
| C6 | 1000 | 800 |
| C65 | 1000 | 800 |
| C8 | 900 | 800 |
| C10 | 500 | 700 |
| C10L | 700 | 900 |

| Size code | Quantity (pcs./Reel, ø380) | Typical weight (g) |
|-----------|----------------------------|--------------------|
| E7 | 1000 | 1100 |
| E10 | 500 | 900 |
| E12 | 400 | 800 |
| F8 | 500 | 1000 |
| F10 | 500 | 1000 |
| F12 | 400 | 1000 |

Packing specifications

◇ Radial lead type (Not recommended for new design)

● Lead terminal process

1-1. Correspondence list

※ The following table is a standard specification. Please contact us separately concerning specifications except for that mentioned below.
 Because of a limit on the length of a model name, the part of process name changes to +S from +TSS, +D from +TS,
 +3 from +C3. Please contact us for details.

| Series | Size code | Bag-packed products (lead terminal cutting) | | Taping products |
|-----------------|-----------------------------------|---|--------------|-----------------|
| | | Not processed | Straight cut | |
| SEP, SEQP, SEPC | B9, C55, C6, C9, C10, E7, E9, E12 | No code | +C3 (+3) | +TSS (+S) |
| SEPF, SXE, SEPG | E13 | No code | +C3 (+3) | +TS (+D) |
| SEF, SEK | F8, F13 | No code | +C3 (+3) | +T |

1-2. Lead terminal cutting specifications

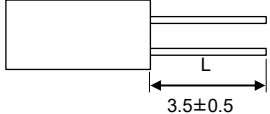
| Process names | Size code | Lead terminal cutting code | Lead terminal dimensions |
|---------------|---|----------------------------|--|
| Straight cut | B9 C55, C6, C9, C10 E7, E9, E12, E13 F8, F13 | +C3 (+3) |  Unit : mm |

1-3. Taping specifications for automatic insertion

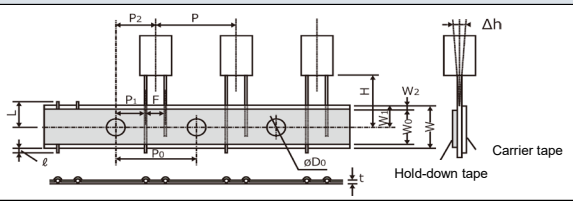
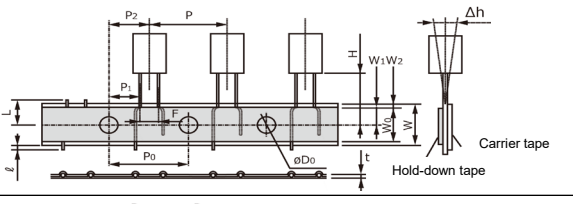
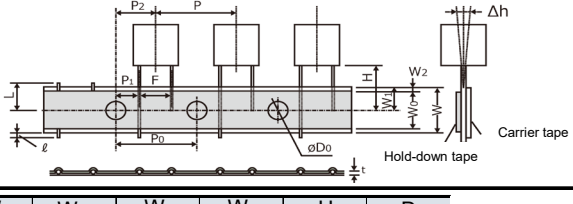
| Size code | Case size | F | Taping code | Taping dimensions |
|------------------|-----------|----------|-------------|--|
| B9 | ø5 | F=2.0 mm | +TSS (+S) |  |
| C55, C6, C9, C10 | ø6.3 | F=2.5 mm | | |
| E7, E9, E12 | ø8 | F=3.5 mm | | |
| E13 | ø8 | F=3.5 mm | +TS (+D) |  |
| F8, F13 | ø10 | F=5.0 mm | +T |  |

| Taping code | Case size | F | P | P ₀ | P ₁ | P ₂ | Δh | W | W ₀ | W ₁ | W ₂ | H | øD ₀ |
|-------------|-----------|-----------------------------------|------|----------------|----------------|----------------|------|------|----------------|----------------|----------------|-------|-----------------|
| | | ^{+0.8} / _{-0.2} | ±1.0 | ±0.2 | ±0.5 | ±1.0 | ±1.0 | ±0.5 | min. | ±0.5 | max. | ±0.75 | ±0.2 |
| +TSS (+S) | ø5 | 2.0 | 12.7 | 12.7 | 5.35 | 6.35 | 0 | 18.0 | 9.5 | 9.0 | 2.5 | 17.5 | 4.0 |
| | ø6.3 | 2.5 | 12.7 | 12.7 | 5.10 | 6.35 | 0 | 18.0 | 9.5 | 9.0 | 2.5 | 17.5 | 4.0 |
| | ø8 | 3.5 | 12.7 | 12.7 | 4.60 | 6.35 | 0 | 18.0 | 9.5 | 9.0 | 2.5 | 17.5 | 4.0 |
| +TS (+D) | ø8 | 3.5 | 12.7 | 12.7 | 4.60 | 6.35 | 0 | 18.0 | 9.5 | 9.0 | 2.5 | 17.5 | 4.0 |
| +T | ø10 | 5.0 | 12.7 | 12.7 | 3.85 | 6.35 | 0 | 18.0 | 9.5 | 9.0 | 2.5 | 18.5 | 4.0 |

| Taping code | Case size | t | ℓ | L |
|-------------|-----------|------|------|------|
| | | ±0.3 | max. | max. |
| +TSS (+S) | ø5 | 0.6 | 0 | 11.0 |
| | ø6.3 | 0.6 | 0 | 11.0 |
| | ø8 | 0.6 | 0 | 11.0 |
| +TS (+D) | ø8 | 0.6 | 0 | 11.0 |
| +T | ø10 | 0.6 | 0 | 11.0 |

Unit : mm

● Minimum packing quantity and weight

| Size code | Case size | Bag-packed products | | Taping products | |
|-----------|-----------|---------------------|-------------------|--------------------|-------------------|
| | | Quantity(pcs./Bag) | Typical weight(g) | Quantity(pcs./Bag) | Typical weight(g) |
| B9 | ø5 | 500 | 180 | 2000 | 1000 |
| C55 | ø6.3 | 500 | 150 | 1500 | 650 |
| C6 | ø6.3 | 500 | 160 | 1500 | 700 |
| C9 | ø6.3 | 500 | 240 | 1500 | 1000 |
| C10 | ø6.3 | 500 | 260 | 1500 | 1100 |

| Size code | Case size | Bag-packed products | | Taping products | |
|-----------|-----------|---------------------|-------------------|--------------------|-------------------|
| | | Quantity(pcs./Bag) | Typical weight(g) | Quantity(pcs./Bag) | Typical weight(g) |
| E7 | ø8 | 200 | 110 | 1000 | 820 |
| E9 | ø8 | 200 | 130 | 1000 | 900 |
| E12 | ø8 | 200 | 200 | 1000 | 980 |
| E13 | ø8 | 200 | 160 | 1000 | 1060 |
| F8 | ø10 | 200 | 180 | 500 | 890 |
| F13 | ø10 | 200 | 280 | 500 | 940 |

**Conductive Polymer Aluminum
Solid Capacitors**
Surface Mount Type
SVT series

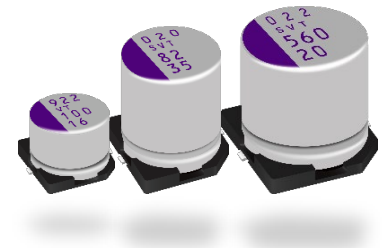

Features

- Low ESR (10 mΩ max.)
- Large capacitance (2700 μF max.)
- 125 °C 2000 h
- RoHS compliance, Halogen free

Specifications

| Size code | C65 | E7 | E10 | E12 | F10 | F12 |
|-----------------------------|---|---|-----|------------|------|------------|
| Category temp. range | -55 °C to +125 °C | | | | | |
| Rated voltage range (V) | 2.5 to 16 | 2.5 to 50 | 16 | 2.5 to 50 | 16 | 2.5 to 50 |
| Nominal cap. range (μF) | 100 to 820 | 18 to 680 | 560 | 39 to 1500 | 1000 | 68 to 2700 |
| Capacitance tolerance | ±20 % (120 Hz / +20 °C) | | | | | |
| DC leakage current | Please see the attached characteristics list | | | | | |
| Dissipation factor (tan δ) | Please see the attached characteristics list | | | | | |
| Endurance | +125 °C 2000 h, rated voltage applied | | | | | |
| | Capacitance change | Within ±20 % of the initial value | | | | |
| | Dissipation factor (tanδ) | ≤ 200 % of the initial limit | | | | |
| | DC leakage current | Within the initial limit | | | | |
| Damp heat (Steady state) | +60 °C, 90 % to 95 % RH, 1000 h, No-applied voltage | | | | | |
| | Capacitance change | Within ±20 % of the initial value | | | | |
| | Dissipation factor (tanδ) | ≤ 150 % of the initial limit | | | | |
| | DC leakage current | Within the initial limit (after voltage processing) | | | | |

Marking

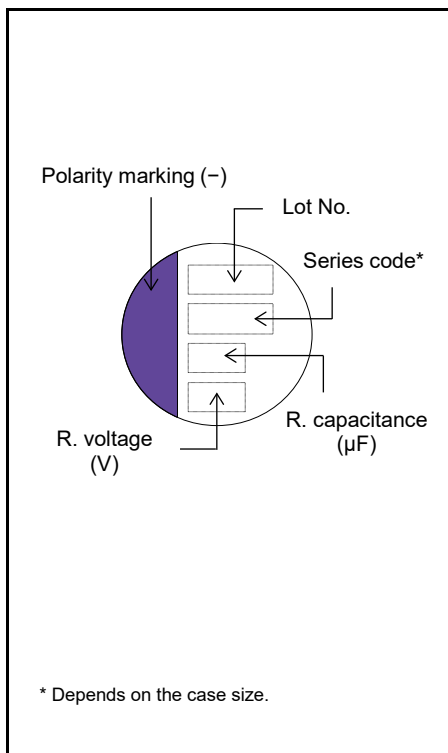

Dimensions (not to scale)

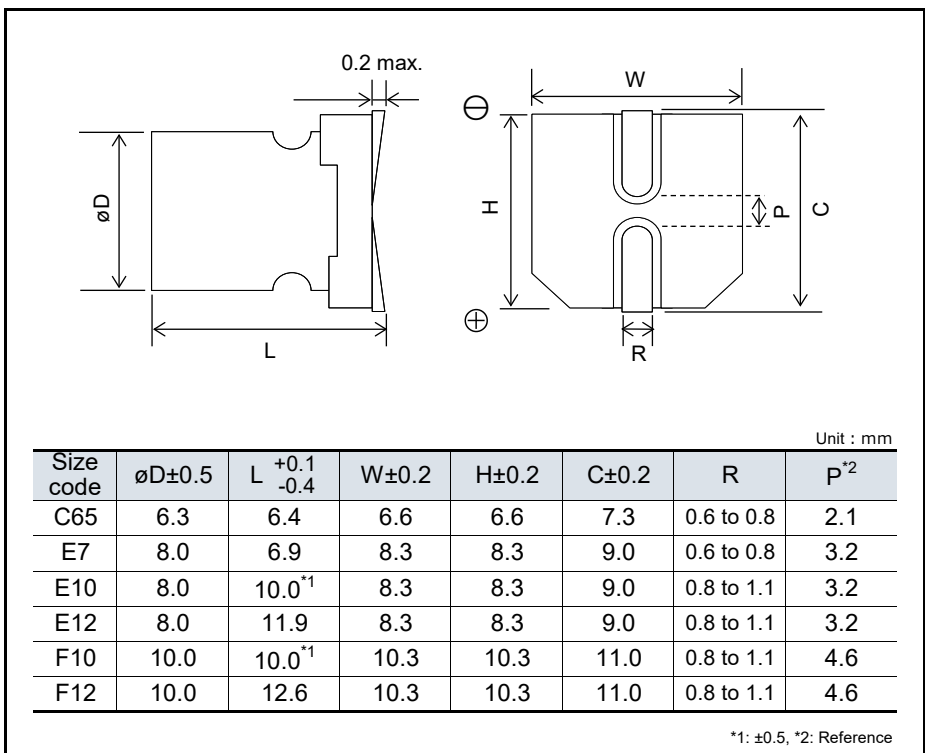

Characteristics list

| Rated voltage (V) | Rated capacitance ($\pm 20\%$) (μF) | Case size (mm) | | Size code | Specifications | | | | | Standard (Reel size : $\phi 380$) | |
|-------------------|--|----------------|------|-----------|---------------------------------------|---|-------------------------------------|------------------------------|------------------------------------|------------------------------------|---------------------------|
| | | ϕD | L | | Ripple current* ¹ (mA rms) | Allowable ripple current* ¹ (mA rms) | ESR* ² (m Ω max.) | $\tan \delta$ * ³ | LC* ⁴ (μA) | Part number | Min. Packaging Q'ty (pcs) |
| 2.5 | 560 | 6.3 | 6.4 | C65 | 1100 | 3500 | 16 | 0.12 | 300 | 2R5SVT560M | 1000 |
| | 680 | 6.3 | 6.4 | | 1000 | 3500 | 16 | 0.12 | 850 | 2R5SVT680MX | 1000 |
| | | | 8.0 | 6.9 | E7 | 1060 | 3370 | 20 | 0.12 | 500 | 2R5SVT680M |
| | 820 | 6.3 | 6.4 | C65 | 1100 | 3500 | 16 | 0.12 | 1020 | 2R5SVT820M | 1000 |
| | 1500 | 8.0 | 11.9 | E12 | 1620 | 5150 | 10 | 0.12 | 750 | 2R5SVT1500M | 400 |
| | 2700 | 10.0 | 12.6 | F12 | 1600 | 5070 | 12 | 0.12 | 1350 | 2R5SVT2700M | 400 |
| 4.0 | 560 | 8.0 | 6.9 | E7 | 1010 | 3220 | 22 | 0.12 | 500 | 4SVT560M | 1000 |
| | 1500 | 8.0 | 11.9 | E12 | 1480 | 4700 | 12 | 0.12 | 1200 | 4SVT1500M | 400 |
| 6.3 | 330 | 6.3 | 6.4 | C65 | 1070 | 3390 | 15 | 0.12 | 415 | 6SVT330M | 1000 |
| | 390 | 8.0 | 6.9 | E7 | 1010 | 3220 | 22 | 0.12 | 491 | 6SVT390M | 1000 |
| | 820 | 8.0 | 11.9 | E12 | 1480 | 4700 | 12 | 0.12 | 1033 | 6SVT820M | 400 |
| 16 | 100 | 6.3 | 6.4 | C65 | 780 | 2490 | 24 | 0.12 | 300 | 16SVT100M | 1000 |
| | 270 | 8.0 | 6.9 | E7 | 1040 | 3300 | 22 | 0.12 | 864 | 16SVT270M | 1000 |
| | 560 | 8.0 | 10.0 | E10 | 1230 | 3900 | 18 | 0.12 | 1792 | 16SVT560MX | 500 |
| | 560 | 8.0 | 11.9 | E12 | 1560 | 4950 | 14 | 0.12 | 1792 | 16SVT560M | 400 |
| | 1000 | 10.0 | 10.0 | F10 | 1350 | 4300 | 16 | 0.12 | 3200 | 16SVT1000MX | 500 |
| | 1000 | 10.0 | 12.6 | F12 | 1700 | 5400 | 12 | 0.12 | 3200 | 16SVT1000M | 400 |
| 20 | 180 | 8.0 | 6.9 | E7 | 1010 | 3200 | 25 | 0.12 | 720 | 20SVT180M | 1000 |
| | 390 | 8.0 | 11.9 | E12 | 1560 | 4950 | 14 | 0.12 | 1560 | 20SVT390M | 400 |
| | 560 | 10.0 | 12.6 | F12 | 1700 | 5400 | 12 | 0.12 | 2240 | 20SVT560M | 400 |
| 25 | 100 | 8.0 | 6.9 | E7 | 1010 | 3200 | 24 | 0.12 | 500 | 25SVT100M | 1000 |
| | 180 | 8.0 | 11.9 | E12 | 1470 | 4650 | 16 | 0.12 | 900 | 25SVT180M | 400 |
| | 330 | 10.0 | 12.6 | F12 | 1580 | 5000 | 14 | 0.12 | 1650 | 25SVT330M | 400 |
| 35 | 39 | 8.0 | 6.9 | E7 | 880 | 2800 | 30 | 0.12 | 273 | 35SVT39M | 1000 |
| | 82 | 8.0 | 11.9 | E12 | 1260 | 4000 | 20 | 0.12 | 574 | 35SVT82M | 400 |
| | 120 | 10.0 | 12.6 | F12 | 1390 | 4400 | 18 | 0.12 | 840 | 35SVT120M | 400 |
| 50 | 18 | 8.0 | 6.9 | E7 | 850 | 2700 | 35 | 0.12 | 180 | 50SVT18M | 1000 |
| | 39 | 8.0 | 11.9 | E12 | 1200 | 3800 | 25 | 0.12 | 390 | 50SVT39M | 400 |
| | 68 | 10.0 | 12.6 | F12 | 1350 | 4300 | 20 | 0.12 | 680 | 50SVT68M | 400 |

*1: Ripple current (100 kHz / $+105\text{ }^\circ\text{C} < T_x \leq +125\text{ }^\circ\text{C}$) / Allowable ripple current (100 kHz / $T_x \leq +105\text{ }^\circ\text{C}$)

Tx: Temperature measured at the top surface of aluminum case including self-heating by ripple current

*2: ESR (100 kHz to 300 kHz / $+20\text{ }^\circ\text{C}$)

*3: $\tan \delta$ (120 Hz / $+20\text{ }^\circ\text{C}$)

*4: After 2 minutes

◆ Please refer to each page in this catalog for "Reflow conditions" and "Taping specifications".

Frequency correction factor for ripple current

| Frequency(f) | $120\text{ Hz} \leq f < 1\text{ kHz}$ | $1\text{ kHz} \leq f < 10\text{ kHz}$ | $10\text{ kHz} \leq f < 100\text{ kHz}$ | $100\text{ kHz} \leq f < 500\text{ kHz}$ |
|--------------|---------------------------------------|---------------------------------------|---|--|
| Coefficient | 0.05 | 0.3 | 0.7 | 1 |

**Conductive Polymer Aluminum
Solid Capacitors**
Surface Mount Type
SVPT series

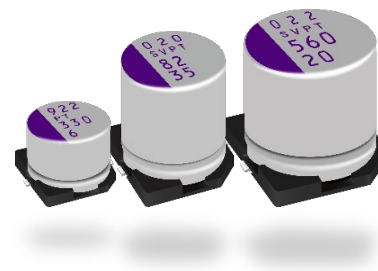

Features

- Low ESR (10 mΩ max.)
- Large capacitance (2700 μF max.)
- 105 °C 20000 h
- RoHS compliance, Halogen free

Specifications

| Size code | C65 | E7 | E10 | E12 | F10 | F12 |
|-----------------------------|---|---|-----|------------|------|------------|
| Category temp. range | -55 °C to +105 °C | | | | | |
| Rated voltage range (V) | 2.5 to 16 | 2.5 to 50 | 16 | 2.5 to 50 | 16 | 2.5 to 50 |
| Nominal cap. range (μF) | 100 to 820 | 18 to 680 | 560 | 39 to 1500 | 1000 | 68 to 2700 |
| Capacitance tolerance | ±20 % (120 Hz / +20 °C) | | | | | |
| DC leakage current | Please see the attached characteristics list | | | | | |
| Dissipation factor (tan δ) | Please see the attached characteristics list | | | | | |
| Endurance | +105 °C 20000 h, rated voltage applied | | | | | |
| | Capacitance change | Within ±20 % of the initial value | | | | |
| | Dissipation factor (tanδ) | ≤ 150 % of the initial limit | | | | |
| | DC leakage current | Within the initial limit | | | | |
| Damp heat (Steady state) | +60 °C, 90 % to 95 % RH, 1000 h, No-applied voltage | | | | | |
| | Capacitance change | Within ±20 % of the initial value | | | | |
| | Dissipation factor (tanδ) | ≤ 150 % of the initial limit | | | | |
| | DC leakage current | Within the initial limit (after voltage processing) | | | | |

Marking

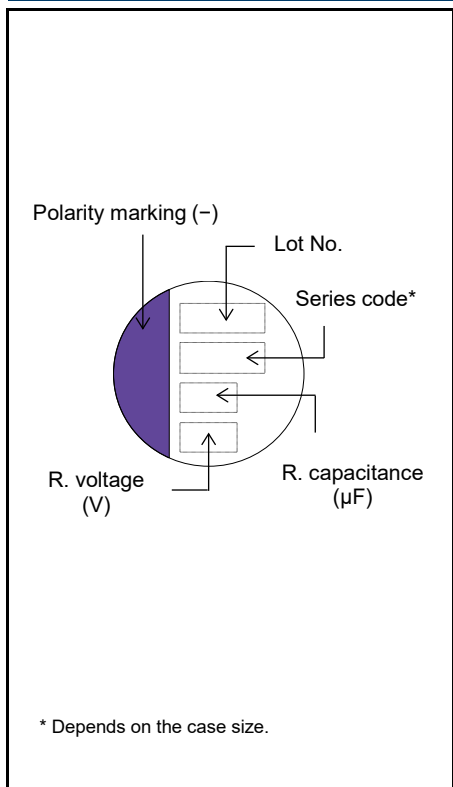

Dimensions (not to scale)

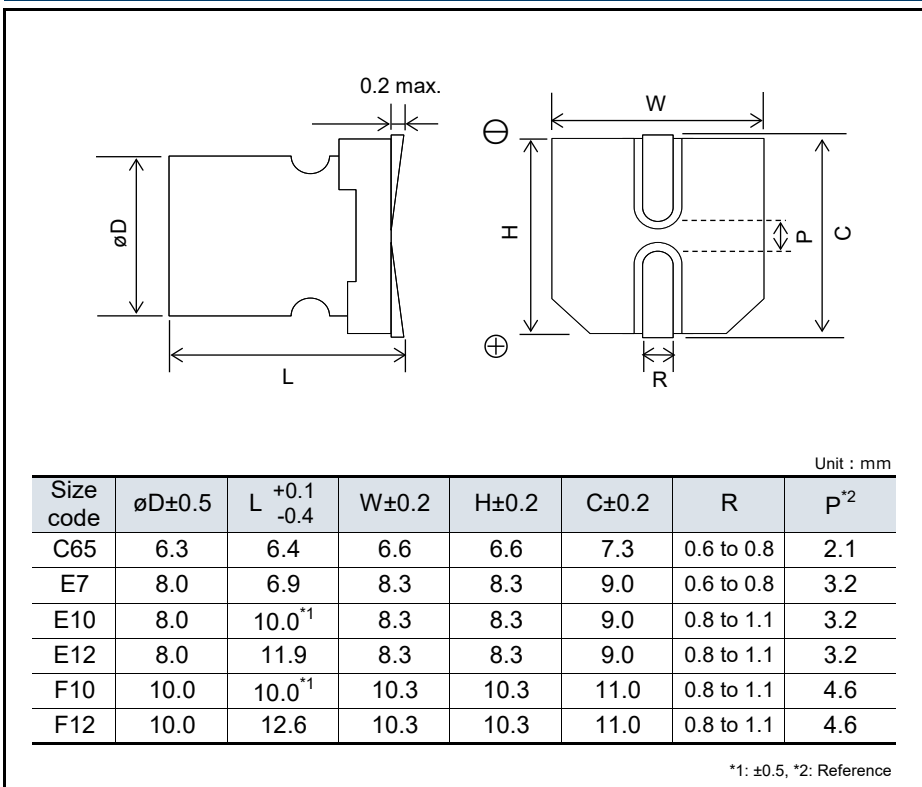

Characteristics list

| Rated voltage (V) | Rated capacitance ($\pm 20\%$) (μF) | Case size (mm) | | Size code | Specifications | | | | Standard (Reel size : $\phi 380$) | |
|-------------------|--|----------------|------|-----------|---------------------------------------|-------------------------------------|-----------------------------|------------------------------------|------------------------------------|---------------------------|
| | | ϕD | L | | Ripple current ^{*1} (mA rms) | ESR ^{*2} (m Ω max.) | $\tan \delta$ ^{*3} | LC ^{*4} (μA) | Part number | Min. Packaging Q'ty (pcs) |
| 2.5 | 560 | 6.3 | 6.4 | C65 | 3500 | 16 | 0.12 | 300 | 2R5SVPT560M | 1000 |
| | 680 | 6.3 | 6.4 | | 3500 | 16 | 0.12 | 850 | 2R5SVPT680MX | 1000 |
| | | 8.0 | 6.9 | E7 | 3370 | 20 | 0.12 | 500 | 2R5SVPT680M | 1000 |
| | 820 | 6.3 | 6.4 | C65 | 3500 | 16 | 0.12 | 1020 | 2R5SVPT820M | 1000 |
| | 1500 | 8.0 | 11.9 | E12 | 5150 | 10 | 0.12 | 750 | 2R5SVPT1500M | 400 |
| 4.0 | 2700 | 10.0 | 12.6 | F12 | 5070 | 12 | 0.12 | 1350 | 2R5SVPT2700M | 400 |
| | 560 | 8.0 | 6.9 | E7 | 3220 | 22 | 0.12 | 500 | 4SVPT560M | 1000 |
| 6.3 | 1500 | 8.0 | 11.9 | E12 | 4700 | 12 | 0.12 | 1200 | 4SVPT1500M | 400 |
| | 330 | 6.3 | 6.4 | C65 | 3390 | 15 | 0.12 | 415 | 6SVPT330M | 1000 |
| | 390 | 8.0 | 6.9 | E7 | 3220 | 22 | 0.12 | 491 | 6SVPT390M | 1000 |
| 16 | 820 | 8.0 | 11.9 | E12 | 4700 | 12 | 0.12 | 1033 | 6SVPT820M | 400 |
| | 100 | 6.3 | 6.4 | C65 | 2490 | 24 | 0.12 | 300 | 16SVPT100M | 1000 |
| | 270 | 8.0 | 6.9 | E7 | 3300 | 22 | 0.12 | 864 | 16SVPT270M | 1000 |
| | 560 | 8.0 | 10.0 | E10 | 3900 | 18 | 0.12 | 1792 | 16SVPT560MX | 500 |
| | 560 | 8.0 | 11.9 | E12 | 4950 | 14 | 0.12 | 1792 | 16SVPT560M | 400 |
| | 1000 | 10.0 | 10.0 | F10 | 4300 | 16 | 0.12 | 3200 | 16SVPT1000MX | 500 |
| 20 | 1000 | 10.0 | 12.6 | F12 | 5400 | 12 | 0.12 | 3200 | 16SVPT1000M | 400 |
| | 180 | 8.0 | 6.9 | E7 | 3200 | 25 | 0.12 | 720 | 20SVPT180M | 1000 |
| | 390 | 8.0 | 11.9 | E12 | 4950 | 14 | 0.12 | 1560 | 20SVPT390M | 400 |
| 25 | 560 | 10.0 | 12.6 | F12 | 5400 | 12 | 0.12 | 2240 | 20SVPT560M | 400 |
| | 100 | 8.0 | 6.9 | E7 | 3200 | 24 | 0.12 | 500 | 25SVPT100M | 1000 |
| | 180 | 8.0 | 11.9 | E12 | 4650 | 16 | 0.12 | 900 | 25SVPT180M | 400 |
| 35 | 330 | 10.0 | 12.6 | F12 | 5000 | 14 | 0.12 | 1650 | 25SVPT330M | 400 |
| | 39 | 8.0 | 6.9 | E7 | 2800 | 30 | 0.12 | 273 | 35SVPT39M | 1000 |
| | 82 | 8.0 | 11.9 | E12 | 4000 | 20 | 0.12 | 574 | 35SVPT82M | 400 |
| 50 | 120 | 10.0 | 12.6 | F12 | 4400 | 18 | 0.12 | 840 | 35SVPT120M | 400 |
| | 18 | 8.0 | 6.9 | E7 | 2700 | 35 | 0.12 | 180 | 50SVPT18M | 1000 |
| | 39 | 8.0 | 11.9 | E12 | 3800 | 25 | 0.12 | 390 | 50SVPT39M | 400 |
| | 68 | 10.0 | 12.6 | F12 | 4300 | 20 | 0.12 | 680 | 50SVPT68M | 400 |

*1: Ripple current (100 kHz / +105 °C)

The surface temperature of aluminum case top must not exceed 105 °C. A rise in temperature due to self-heating by ripple current should be factored in.

*2: ESR (100 kHz to 300 kHz / +20 °C)

*3: $\tan \delta$ (120 Hz / +20 °C)

*4: After 2 minutes

◆ Please refer to each page in this catalog for "Reflow conditions" and "Taping specifications".

Frequency correction factor for ripple current

| Frequency(f) | 120 Hz \leq f < 1 kHz | 1 kHz \leq f < 10 kHz | 10 kHz \leq f < 100 kHz | 100 kHz \leq f < 500 kHz |
|--------------|-------------------------|-------------------------|---------------------------|----------------------------|
| Coefficient | 0.05 | 0.3 | 0.7 | 1 |

**Conductive Polymer Aluminum
Solid Capacitors**
Surface Mount Type
SVF series

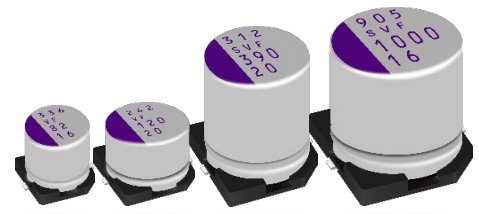

Features

- High voltage (50 V max.)
- Large capacitance (1000 μF max.)
- 125 °C 1000 h
- RoHS compliance, Halogen free

Specifications

| Size code | B6 | C6 | E7 | E12 | F10 | F12 |
|-----------------------------|---|---|-----------------|-----------------|---------|------------------|
| Category temp. range | -55 °C to +125 °C | | | | | |
| Rated voltage range | 16 V to 25 V | 16 V to 50 V | | | 16 V | 16 V to 50 V |
| Nominal cap.range | 27 μF to 82 μF | 10 μF to 180 μF | 18 μF to 270 μF | 39 μF to 560 μF | 1000 μF | 68 μF to 1000 μF |
| Capacitance tolerance | ±20 % (120 Hz / +20 °C) | | | | | |
| DC leakage current | Please see the attached characteristics list | | | | | |
| Dissipation factor (tan δ) | Please see the attached characteristics list | | | | | |
| Endurance | +125 °C 1000 h, rated voltage applied | | | | | |
| | Capacitance change | Within ±20 % of the initial value | | | | |
| | Dissipation factor (tanδ) | ≤ 200 % of the initial limit | | | | |
| | DC leakage current | Within the initial limit | | | | |
| Damp heat (Steady state) | +60 °C, 90 % to 95 % RH, 1000 h, No-applied voltage | | | | | |
| | Capacitance change | Within ±20 % of the initial value | | | | |
| | Dissipation factor (tanδ) | ≤ 150 % of the initial limit | | | | |
| | DC leakage current | Within the initial limit (after voltage processing) | | | | |

Marking

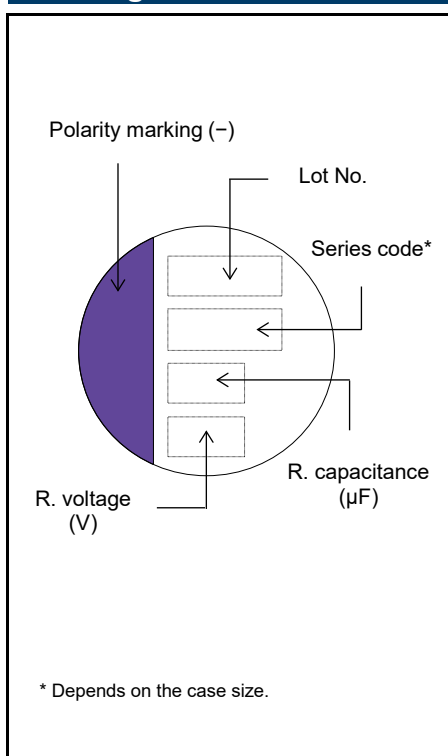

Dimensions (not to scale)

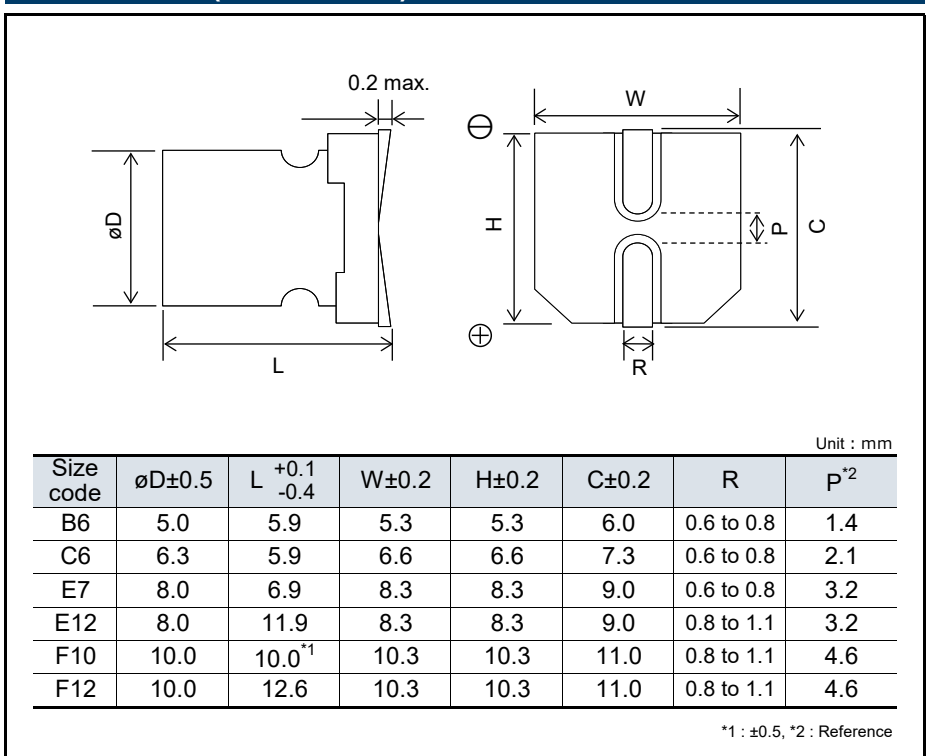

Characteristics list

| Rated voltage (V) | Rated capacitance (±20 %) (μF) | Case size (mm) | | Size code | Specifications | | | | | Standard (Reel size : ø380) | |
|-------------------|--------------------------------|----------------|------|-----------|---------------------------------------|---|-----------------------------|---------------------|-----------------------|-----------------------------|---------------------------|
| | | øD | L | | Ripple current* ¹ (mA rms) | Allowable ripple current* ¹ (mA rms) | ESR* ² (mΩ max.) | tan δ* ³ | LC* ⁴ (μA) | Part number | Min. Packaging Q'ty (pcs) |
| 16 | 82 | 5.0 | 5.9 | B6 | 940 | 3000 | 27 | 0.12 | 262 | 16SVF82M | 1500 |
| | 180 | 6.3 | 5.9 | C6 | 1040 | 3300 | 22 | 0.12 | 576 | 16SVF180M | 1000 |
| | 270 | 8.0 | 6.9 | E7 | 1040 | 3300 | 22 | 0.12 | 864 | 16SVF270M | 1000 |
| | 560 | 8.0 | 11.9 | E12 | 1560 | 4950 | 14 | 0.12 | 1792 | 16SVF560M | 400 |
| | 1000 | 10.0 | 10.0 | F10 | 1350 | 4300 | 16 | 0.12 | 3200 | 16SVF1000MX | 500 |
| | | 10.0 | 12.6 | F12 | 1700 | 5400 | 12 | 0.12 | 3200 | 16SVF1000M | 400 |
| 20 | 56 | 5.0 | 5.9 | B6 | 880 | 2800 | 30 | 0.12 | 224 | 20SVF56M | 1500 |
| | 120 | 6.3 | 5.9 | C6 | 1010 | 3200 | 25 | 0.12 | 480 | 20SVF120M | 1000 |
| | 180 | 8.0 | 6.9 | E7 | 1010 | 3200 | 25 | 0.12 | 720 | 20SVF180M | 1000 |
| | 390 | 8.0 | 11.9 | E12 | 1560 | 4950 | 14 | 0.12 | 1560 | 20SVF390M | 400 |
| | 560 | 10.0 | 12.6 | F12 | 1700 | 5400 | 12 | 0.12 | 2240 | 20SVF560M | 400 |
| 25 | 27 | 5.0 | 5.9 | B6 | 770 | 2450 | 40 | 0.12 | 135 | 25SVF27M | 1500 |
| | 47 | 6.3 | 5.9 | C6 | 880 | 2800 | 30 | 0.12 | 235 | 25SVF47M | 1000 |
| | 56 | 6.3 | 5.9 | | 880 | 2800 | 30 | 0.12 | 280 | 25SVF56M | 1000 |
| | 82 | 8.0 | 6.9 | E7 | 940 | 3000 | 28 | 0.12 | 410 | 25SVF82M | 1000 |
| | 100 | 8.0 | 6.9 | | 1010 | 3200 | 24 | 0.12 | 500 | 25SVF100M | 1000 |
| | 180 | 8.0 | 11.9 | E12 | 1470 | 4650 | 16 | 0.12 | 900 | 25SVF180M | 400 |
| | 330 | 10.0 | 12.6 | F12 | 1580 | 5000 | 14 | 0.12 | 1650 | 25SVF330M | 400 |
| 35 | 22 | 6.3 | 5.9 | C6 | 820 | 2600 | 35 | 0.12 | 154 | 35SVF22M | 1000 |
| | 39 | 8.0 | 6.9 | E7 | 880 | 2800 | 30 | 0.12 | 273 | 35SVF39M | 1000 |
| | 82 | 8.0 | 11.9 | E12 | 1260 | 4000 | 20 | 0.12 | 574 | 35SVF82M | 400 |
| | 120 | 10.0 | 12.6 | F12 | 1390 | 4400 | 18 | 0.12 | 840 | 35SVF120M | 400 |
| 50 | 10 | 6.3 | 5.9 | C6 | 790 | 2500 | 40 | 0.12 | 100 | 50SVF10M | 1000 |
| | 18 | 8.0 | 6.9 | E7 | 850 | 2700 | 35 | 0.12 | 180 | 50SVF18M | 1000 |
| | 39 | 8.0 | 11.9 | E12 | 1200 | 3800 | 25 | 0.12 | 390 | 50SVF39M | 400 |
| | 68 | 10.0 | 12.6 | F12 | 1350 | 4300 | 20 | 0.12 | 680 | 50SVF68M | 400 |

*1: Ripple current (100 kHz / +105 °C < Tx ≤ +125 °C) / Allowable ripple current (100 kHz / Tx ≤ +105 °C)

*2: ESR (100 kHz to 300 kHz / +20 °C)

*3: tan δ (120 Hz / +20 °C)

*4: After 2 minutes

◆ Please refer to each page in this catalog for "Reflow conditions" and "Taping specifications".

Frequency correction factor for ripple current

| Frequency(f) | 120 Hz ≤ f < 1 kHz | 1 kHz ≤ f < 10 kHz | 10 kHz ≤ f < 100 kHz | 100 kHz ≤ f < 500 kHz |
|--------------|--------------------|--------------------|----------------------|-----------------------|
| Coefficient | 0.05 | 0.3 | 0.7 | 1 |

**Conductive Polymer Aluminum
Solid Capacitors**
Surface Mount Type
SVPK series



Features

- High voltage (50 V max.)
- 125 °C 1000 h
- RoHS compliance, Halogen free

Specifications

| Size code | B6 | C6 | E7 | E12 | F12 |
|----------------------------|---|---|-----------------|-----------------|-------------------|
| Category temp. range | -55 °C to +125 °C | | | | |
| Rated voltage range | 16 V to 50 V | | | | |
| Nominal cap.range | 10 µF to 100 µF | 22 µF to 220 µF | 33 µF to 330 µF | 68 µF to 680 µF | 120 µF to 1200 µF |
| Capacitance tolerance | ±20 % (120 Hz / +20 °C) | | | | |
| DC leakage current | Please see the attached characteristics list | | | | |
| Dissipation factor (tan δ) | Please see the attached characteristics list | | | | |
| Endurance | +125 °C 1000 h, rated voltage applied | | | | |
| | Capacitance change | Within ±20 % of the initial value | | | |
| | Dissipation factor (tanδ) | ≤ 200 % of the initial limit | | | |
| | DC leakage current | Within the initial limit | | | |
| Damp heat (Steady state) | +60 °C, 90 % to 95 % RH, 1000 h, No-applied voltage | | | | |
| | Capacitance change | Within ±20 % of the initial value | | | |
| | Dissipation factor (tanδ) | ≤ 150 % of the initial limit | | | |
| | DC leakage current | Within the initial limit (after voltage processing) | | | |

Marking

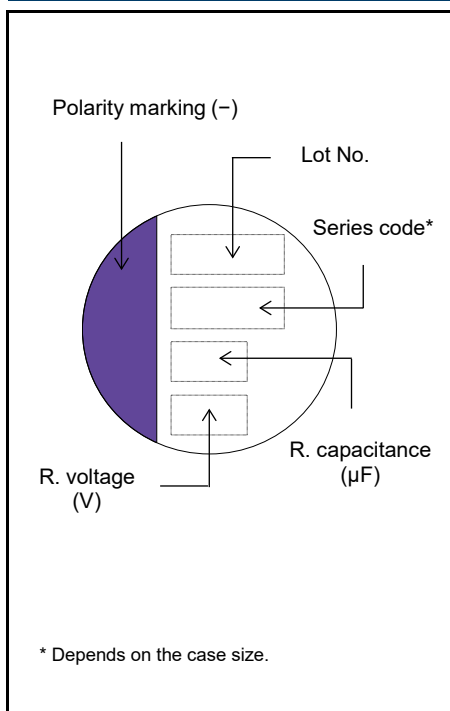

Dimensions (not to scale)

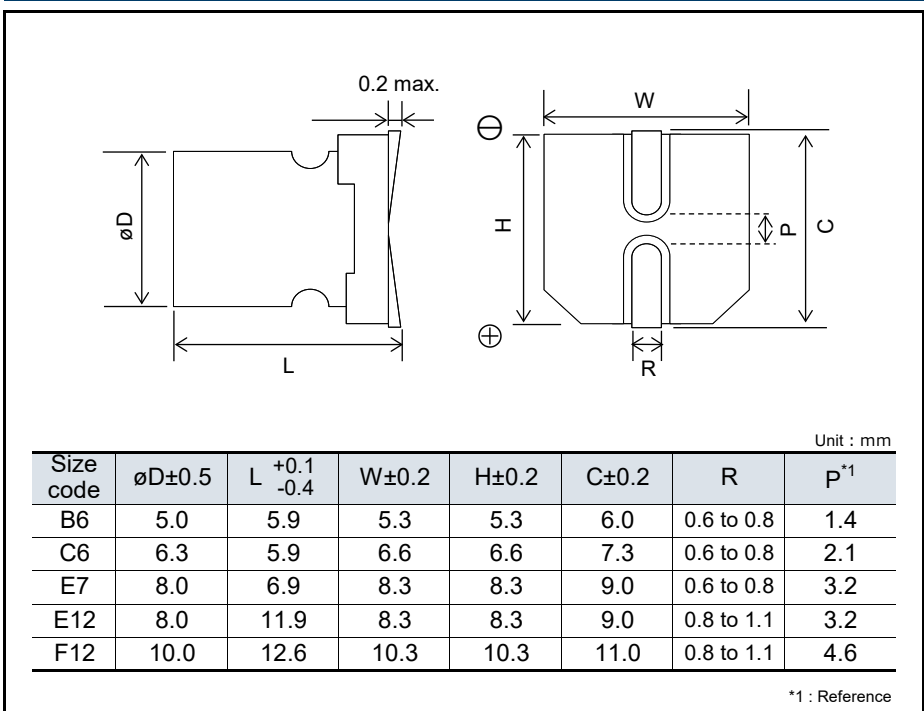

Characteristics list

| Rated voltage (V) | Rated capacitance (±20 %) (μF) | Case size (mm) | | Size code | Specifications | | | | | Standard (Reel size : ø380) | |
|-------------------|--------------------------------|----------------|------|-----------|---------------------------------------|---|-----------------------------|---------------------|-----------------------|-----------------------------|---------------------------|
| | | øD | L | | Ripple current* ¹ (mA rms) | Allowable ripple current* ¹ (mA rms) | ESR* ² (mΩ max.) | tan δ* ³ | LC* ⁴ (μA) | Part number | Min. Packaging Q'ty (pcs) |
| 16 | 100 | 5.0 | 5.9 | B6 | 940 | 3000 | 27 | 0.12 | 320 | 16SVPK100M | 1500 |
| | 220 | 6.3 | 5.9 | C6 | 1040 | 3300 | 22 | 0.12 | 704 | 16SVPK220M | 1000 |
| | 330 | 8.0 | 6.9 | E7 | 1040 | 3300 | 22 | 0.12 | 1056 | 16SVPK330M | 1000 |
| | 680 | 8.0 | 11.9 | E12 | 1560 | 4950 | 14 | 0.12 | 2176 | 16SVPK680M | 400 |
| | 1200 | 10.0 | 12.6 | F12 | 1700 | 5400 | 12 | 0.12 | 3840 | 16SVPK1200M | 400 |
| 20 | 68 | 5.0 | 5.9 | B6 | 880 | 2800 | 30 | 0.12 | 272 | 20SVPK68M | 1500 |
| | 150 | 6.3 | 5.9 | C6 | 1010 | 3200 | 25 | 0.12 | 600 | 20SVPK150M | 1000 |
| | 220 | 8.0 | 6.9 | E7 | 1010 | 3200 | 25 | 0.12 | 880 | 20SVPK220M | 1000 |
| | 470 | 8.0 | 11.9 | E12 | 1560 | 4950 | 14 | 0.12 | 1880 | 20SVPK470M | 400 |
| | 680 | 10.0 | 12.6 | F12 | 1700 | 5400 | 12 | 0.12 | 2720 | 20SVPK680M | 400 |
| 25 | 33 | 5.0 | 5.9 | B6 | 820 | 2600 | 35 | 0.12 | 165 | 25SVPK33M | 1500 |
| | 82 | 6.3 | 5.9 | C6 | 960 | 3060 | 25 | 0.12 | 410 | 25SVPK82M | 1000 |
| | 120 | 8.0 | 6.9 | E7 | 1010 | 3200 | 24 | 0.12 | 600 | 25SVPK120M | 1000 |
| | 270 | 8.0 | 11.9 | E12 | 1470 | 4650 | 16 | 0.12 | 1350 | 25SVPK270M | 400 |
| | 470 | 10.0 | 12.6 | F12 | 1590 | 5000 | 14 | 0.12 | 2350 | 25SVPK470M | 400 |
| 35 | 22 | 5.0 | 5.9 | B6 | 820 | 2600 | 35 | 0.12 | 154 | 35SVPK22M | 1500 |
| | 47 | 6.3 | 5.9 | C6 | 930 | 2950 | 27 | 0.12 | 329 | 35SVPK47M | 1000 |
| | 82 | 8.0 | 6.9 | E7 | 960 | 3060 | 25 | 0.12 | 574 | 35SVPK82M | 1000 |
| | 180 | 8.0 | 11.9 | E12 | 1260 | 4000 | 20 | 0.12 | 1260 | 35SVPK180M | 400 |
| | 330 | 10.0 | 12.6 | F12 | 1390 | 4400 | 18 | 0.12 | 2310 | 35SVPK330M | 400 |
| 50 | 10 | 5.0 | 5.9 | B6 | 550 | 1750 | 80 | 0.12 | 100 | 50SVPK10M | 1500 |
| | 22 | 6.3 | 5.9 | C6 | 820 | 2600 | 35 | 0.12 | 220 | 50SVPK22M | 1000 |
| | 33 | 8.0 | 6.9 | E7 | 850 | 2700 | 35 | 0.12 | 330 | 50SVPK33M | 1000 |
| | 68 | 8.0 | 11.9 | E12 | 1200 | 3800 | 25 | 0.12 | 680 | 50SVPK68M | 400 |
| | 120 | 10.0 | 12.6 | F12 | 1350 | 4300 | 20 | 0.12 | 1200 | 50SVPK120M | 400 |

*1: Ripple current (100 kHz / +105 °C < Tx ≤ +125 °C) / Allowable ripple current (100 kHz / Tx ≤ +105 °C)

*2: ESR (100 kHz to 300 kHz / +20 °C)

*3: tan δ (120 Hz / +20 °C)

*4: After 2 minutes

◆ Please refer to each page in this catalog for "Reflow conditions" and "Taping specifications".

Frequency correction factor for ripple current

| Frequency(f) | 120 Hz ≤ f < 1 kHz | 1 kHz ≤ f < 10 kHz | 10 kHz ≤ f < 100 kHz | 100 kHz ≤ f < 500 kHz |
|--------------|--------------------|--------------------|----------------------|-----------------------|
| Coefficient | 0.05 | 0.3 | 0.7 | 1 |

Conductive Polymer Aluminum
Solid Capacitors
Surface Mount Type
SXV series



Features

- Super high voltage (100 V max.)
- 125 °C 1000 h
- RoHS compliance, Halogen free

Specifications

| Size code | E7 | E12 | F8 | F12 |
|----------------------------|---|---|----------------|-----------------|
| Category temp. range | -55 °C to +125 °C | | | |
| Rated voltage range | 63 V to 100 V | | | |
| Nominal cap.range | 6.8 μF to 18 μF | 15 μF to 82 μF | 15 μF to 39 μF | 18 μF to 150 μF |
| Capacitance tolerance | ±20 % (120 Hz / +20 °C) | | | |
| DC leakage current | Please see the attached characteristics list | | | |
| Dissipation factor (tan δ) | Please see the attached characteristics list | | | |
| Endurance | +125 °C 1000 h, rated voltage applied | | | |
| | Capacitance change | Within ±20 % of the initial value | | |
| | Dissipation factor (tanδ) | Within the initial limit | | |
| Damp heat (Steady state) | +60 °C, 90 % to 95 % RH, 1000 h, No-applied voltage | | | |
| | Capacitance change | Within ±20 % of the initial value | | |
| | Dissipation factor (tanδ) | ≤ 150 % of the initial limit | | |
| | DC leakage current | Within the initial limit (after voltage processing) | | |

Marking

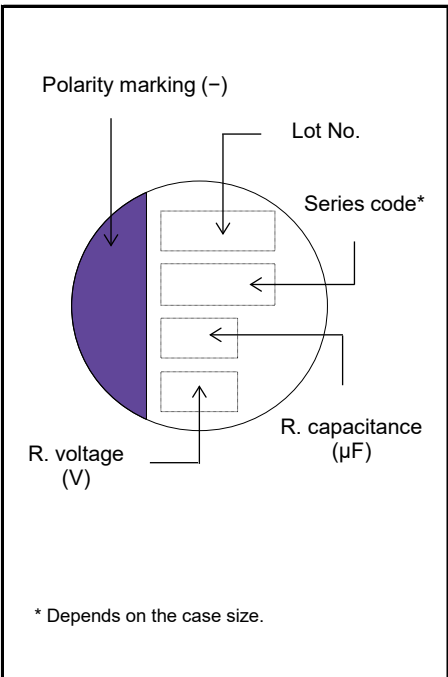

Dimensions (not to scale)

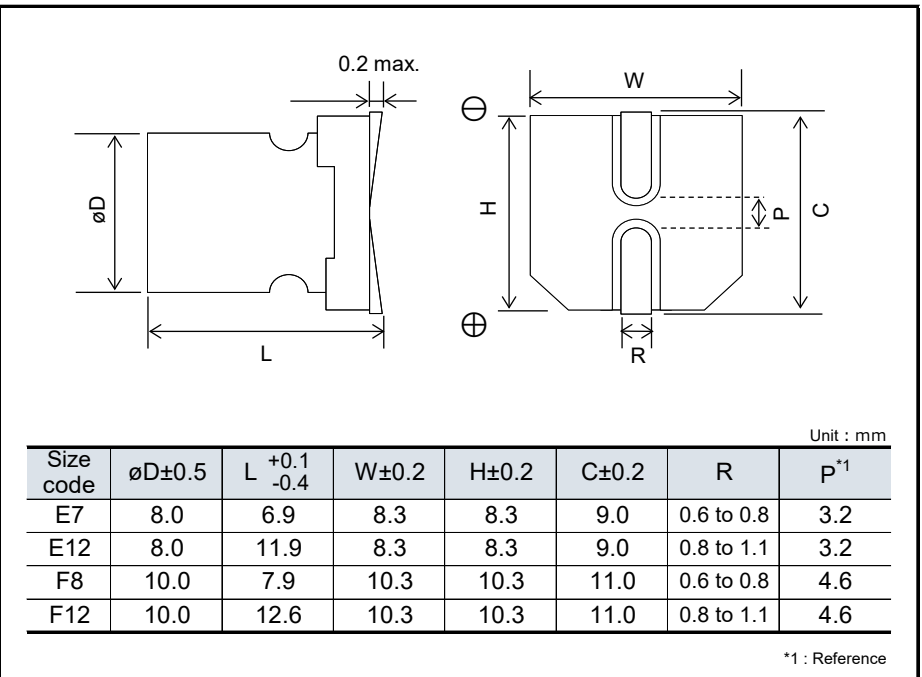

Characteristics list

| Rated voltage (V) | Rated capacitance (±20 %) (μF) | Case size (mm) | | Size code | Specifications | | | | | Standard (Reel size : ø380) | |
|-------------------|--------------------------------|----------------|------|-----------|---------------------------------------|---|-----------------------------|---------------------|-----------------------|-----------------------------|---------------------------|
| | | øD | L | | Ripple current* ¹ (mA rms) | Allowable ripple current* ¹ (mA rms) | ESR* ² (mΩ max.) | tan δ* ³ | LC* ⁴ (μA) | Part number | Min. Packaging Q'ty (pcs) |
| 63 | 18 | 8.0 | 6.9 | E7 | 340 | 1100 | 60 | 0.12 | 56 | 63SXV18M | 1000 |
| | 33 | 8.0 | 11.9 | E12 | 930 | 2950 | 25 | 0.12 | 104 | 63SXV33M | 400 |
| | 39 | 8.0 | 11.9 | E12 | 930 | 2950 | 25 | 0.12 | 122 | 63SXV39M | 400 |
| | | 10.0 | 7.9 | F8 | 690 | 2190 | 50 | 0.12 | 122 | 63SXV39MX | 500 |
| | 56 | 8.0 | 11.9 | E12 | 930 | 2950 | 25 | 0.12 | 176 | 63SXV56M | 400 |
| | 68 | 8.0 | 11.9 | E12 | 930 | 2950 | 25 | 0.12 | 214 | 63SXV68MX | 400 |
| | | 10.0 | 12.6 | F12 | 1030 | 3280 | 25 | 0.12 | 214 | 63SXV68M | 400 |
| | 82 | 8.0 | 11.9 | E12 | 930 | 2950 | 25 | 0.12 | 258 | 63SXV82M | 400 |
| | 100 | 10.0 | 12.6 | F12 | 1030 | 3280 | 25 | 0.12 | 315 | 63SXV100M | 400 |
| | 120 | 10.0 | 12.6 | F12 | 1030 | 3280 | 25 | 0.12 | 378 | 63SXV120M | 400 |
| 150 | 10.0 | 12.6 | F12 | 1030 | 3280 | 25 | 0.12 | 472 | 63SXV150M | 400 | |
| 72 | 82 | 10.0 | 12.6 | F12 | 980 | 3100 | 28 | 0.12 | 295 | 72SXV82M | 400 |
| | 100 | 10.0 | 12.6 | F12 | 980 | 3100 | 28 | 0.12 | 360 | 72SXV100M | 400 |
| 80 | 12 | 8.0 | 6.9 | E7 | 340 | 1100 | 60 | 0.12 | 48 | 80SXV12M | 1000 |
| | 27 | 8.0 | 11.9 | E12 | 780 | 2490 | 35 | 0.12 | 108 | 80SXV27M | 400 |
| | | 10.0 | 7.9 | F8 | 660 | 2080 | 55 | 0.12 | 108 | 80SXV27MX | 500 |
| | 33 | 8.0 | 11.9 | E12 | 780 | 2490 | 35 | 0.12 | 132 | 80SXV33M | 400 |
| | 47 | 8.0 | 11.9 | E12 | 780 | 2490 | 35 | 0.12 | 188 | 80SXV47MX | 400 |
| | | 10.0 | 12.6 | F12 | 980 | 3100 | 28 | 0.12 | 188 | 80SXV47M | 400 |
| | 56 | 8.0 | 11.9 | E12 | 780 | 2490 | 35 | 0.12 | 224 | 80SXV56MX | 400 |
| | | 10.0 | 12.6 | F12 | 980 | 3100 | 28 | 0.12 | 224 | 80SXV56M | 400 |
| | 82 | 10.0 | 12.6 | F12 | 980 | 3100 | 28 | 0.12 | 328 | 80SXV82M | 400 |
| | 100 | 10.0 | 12.6 | F12 | 980 | 3100 | 28 | 0.12 | 400 | 80SXV100M | 400 |
| 100 | 6.8 | 8.0 | 6.9 | E7 | 340 | 1100 | 60 | 0.12 | 34 | 100SXV6R8M | 1000 |
| | 15 | 10.0 | 7.9 | F8 | 630 | 2000 | 60 | 0.12 | 75 | 100SXV15MX | 500 |
| | | 8.0 | 11.9 | E12 | 730 | 2350 | 40 | 0.12 | 75 | 100SXV15M | 400 |
| | 18 | 10.0 | 12.6 | F12 | 940 | 3000 | 30 | 0.12 | 90 | 100SXV18M | 400 |
| | | 8.0 | 11.9 | E12 | 730 | 2350 | 40 | 0.12 | 90 | 100SXV18MX | 400 |
| | 22 | 10.0 | 12.6 | F12 | 940 | 3000 | 30 | 0.12 | 110 | 100SXV22M | 400 |
| | 27 | 8.0 | 11.9 | E12 | 730 | 2350 | 40 | 0.12 | 135 | 100SXV27MX | 400 |
| | | 10.0 | 12.6 | F12 | 940 | 3000 | 30 | 0.12 | 135 | 100SXV27M | 400 |
| | 39 | 10.0 | 12.6 | F12 | 940 | 3000 | 30 | 0.12 | 195 | 100SXV39M | 400 |

*1: Ripple current (100 kHz / +105 °C < Tx ≤ +125 °C) / Allowable ripple current (100 kHz / Tx ≤ +105 °C)

*2: ESR (100 kHz to 300 kHz / +20 °C)

*3: tan δ (120 Hz / +20 °C)

*4: After 2 minutes

◆ Please refer to each page in this catalog for "Reflow conditions" and "Taping specifications".

Frequency correction factor for ripple current

| Frequency(f) | 120 Hz ≤ f < 1 kHz | 1 kHz ≤ f < 10 kHz | 10 kHz ≤ f < 100 kHz | 100 kHz ≤ f < 500 kHz |
|--------------|--------------------|--------------------|----------------------|-----------------------|
| Coefficient | 0.05 | 0.3 | 0.7 | 1 |

Conductive Polymer Aluminum Solid Capacitors

Surface Mount Type

SVPG series



Features

- Low profile (Height 4.5 mm max.)
- Low ESR (6.5 mΩ max.)
- High ripple current (7500 mA rms max.)
- RoHS compliance, Halogen free

Specifications

| Size code | B45 | B6 | C6 | C8 | C10 | C10L | E7 | E10 | E12 | F10 | F12 |
|----------------------------|---|---|-----------|------------|------------|------|------------|-----|------------|-----|-------------|
| Category temp. range | -55 °C to +105 °C | | | | | | | | | | |
| Rated voltage range (V) | 16 to 25 | 16 | 16 ~ 25 | | | 16 | 16 ~ 25 | 16 | 16 to 25 | 16 | 16 to 25 |
| Nominal cap.range (μF) | 15 to 47 | 100 | 82 to 220 | 120 to 270 | 150 to 270 | 330 | 120 to 330 | 560 | 270 to 680 | 820 | 470 to 1200 |
| Capacitance tolerance | ±20 % (120 Hz / +20 °C) | | | | | | | | | | |
| DC leakage current | Please see the attached characteristics list | | | | | | | | | | |
| Dissipation factor (tan δ) | Please see the attached characteristics list | | | | | | | | | | |
| Endurance | +105 °C 5000 h, rated voltage applied | | | | | | | | | | |
| | Capacitance change | Within ±20 % of the initial value | | | | | | | | | |
| | Dissipation factor (tanδ) | ≤ 150 % of the initial limit | | | | | | | | | |
| | DC leakage current | Within the initial limit | | | | | | | | | |
| Damp heat (Steady state) | +60 °C, 90 % to 95 % RH, 1000 h, No-applied voltage | | | | | | | | | | |
| | Capacitance change | Within ±20 % of the initial value | | | | | | | | | |
| | Dissipation factor (tanδ) | ≤ 150 % of the initial limit | | | | | | | | | |
| | DC leakage current | Within the initial limit (after voltage processing) | | | | | | | | | |

Marking

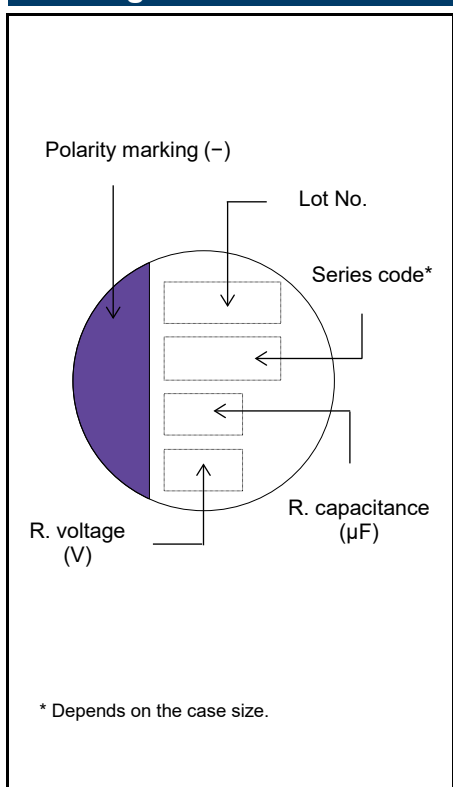

Dimensions (not to scale)

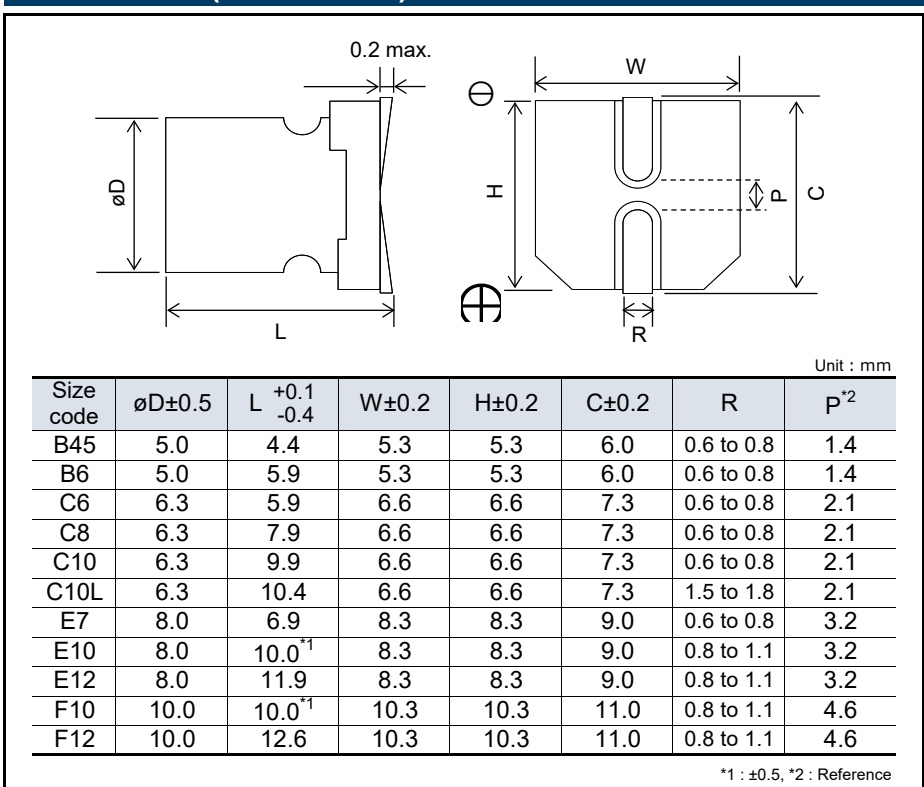

Characteristics list

| Rated voltage (V) | Rated capacitance (±20 %) (μF) | Case size (mm) | | Size code | Specifications | | | | Standard (Reel size : ø380) | |
|-------------------|--------------------------------|----------------|------|-----------|---------------------------------------|-----------------------------|---------------------|-----------------------|-----------------------------|---------------------------|
| | | øD | L | | Ripple current* ¹ (mA rms) | ESR* ² (mΩ max.) | tan δ* ³ | LC* ⁴ (μA) | Part number | Min. Packaging Q'ty (pcs) |
| 16 | 47 | 5.0 | 4.4 | B45 | 3200 | 25 | 0.12 | 150 | 16SVPG47M | 2500 |
| | 100 | 5.0 | 5.9 | B6 | 4000 | 15 | 0.12 | 320 | 16SVPG100M | 1500 |
| | 220 | 6.3 | 5.9 | C6 | 4100 | 14 | 0.12 | 704 | 16SVPG220M | 1000 |
| | 270 | 6.3 | 7.9 | C8 | 5080 | 10 | 0.12 | 864 | 16SVPG270MX | 900 |
| | | 6.3 | 9.9 | C10 | 5800 | 8 | 0.12 | 864 | 16SVPG270M | 500 |
| | 330 | 6.3 | 10.4 | C10L | 7500 | 6.5 | 0.12 | 1056 | 16SVPG330M | 700 |
| | | 8.0 | 6.9 | E7 | 4100 | 16 | 0.12 | 1056 | 16SVPG330MX | 1000 |
| | 560 | 8.0 | 10.0 | E10 | 5200 | 10 | 0.12 | 1792 | 16SVPG560M | 500 |
| | 680 | 8.0 | 11.9 | E12 | 6500 | 8 | 0.12 | 2176 | 16SVPG680M | 400 |
| 820 | 10.0 | 10.0 | F10 | 5700 | 9 | 0.12 | 2624 | 16SVPG820M | 500 | |
| 1200 | 10.0 | 12.6 | F12 | 7000 | 7 | 0.12 | 3840 | 16SVPG1200M | 400 | |
| 20 | 33 | 5.0 | 4.4 | B45 | 3000 | 27 | 0.12 | 132 | 20SVPG33M | 2500 |
| | 120 | 6.3 | 5.9 | C6 | 3750 | 18 | 0.12 | 480 | 20SVPG120M | 1000 |
| | 180 | 6.3 | 7.9 | C8 | 4200 | 14 | 0.12 | 720 | 20SVPG180MX | 900 |
| | | 6.3 | 9.9 | C10 | 4700 | 11 | 0.12 | 720 | 20SVPG180M | 500 |
| | 220 | 8.0 | 6.9 | E7 | 3750 | 18 | 0.12 | 880 | 20SVPG220M | 1000 |
| | 470 | 8.0 | 11.9 | E12 | 5850 | 10 | 0.12 | 1880 | 20SVPG470M | 400 |
| | 680 | 10.0 | 12.6 | F12 | 6200 | 9 | 0.12 | 2720 | 20SVPG680M | 400 |
| 25 | NRFND 15 | 5.0 | 4.4 | B45 | 2800 | 30 | 0.12 | 75 | 25SVPG15M | 2500 |
| | 82 | 6.3 | 5.9 | C6 | 3750 | 18 | 0.12 | 410 | 25SVPG82M | 1000 |
| | 120 | 6.3 | 7.9 | C8 | 3900 | 15 | 0.12 | 600 | 25SVPG120MX | 900 |
| | | 8.0 | 6.9 | E7 | 3800 | 17 | 0.12 | 600 | 25SVPG120M | 1000 |
| | 150 | 6.3 | 9.9 | C10 | 4200 | 13 | 0.12 | 750 | 25SVPG150M | 500 |
| | 270 | 8.0 | 11.9 | E12 | 5350 | 12 | 0.12 | 1350 | 25SVPG270M | 400 |
| | 470 | 10.0 | 12.6 | F12 | 5900 | 10 | 0.12 | 2350 | 25SVPG470M | 400 |

*1: Ripple current (100 kHz / +105 °C)

*2: ESR (100 kHz to 300 kHz / +20 °C)

NRFND Not recommended for new design

*3: tan δ (120 Hz / +20 °C)

*4: After 2 minutes

◆ Please refer to each page in this catalog for "Reflow conditions" and "Taping specifications".

Frequency correction factor for ripple current

| Frequency(f) | 120 Hz ≤ f < 1 kHz | 1 kHz ≤ f < 10 kHz | 10 kHz ≤ f < 100 kHz | 100 kHz ≤ f < 500 kHz |
|--------------|--------------------|--------------------|----------------------|-----------------------|
| Coefficient | 0.05 | 0.3 | 0.7 | 1 |

**Conductive Polymer Aluminum
Solid Capacitors**
Surface Mount Type
SVPF series

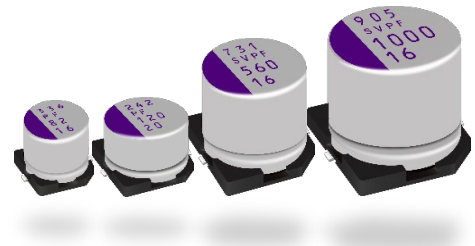

Features

- High voltage (50 V max.)
- Large capacitance (1000 μ F max.)
- 105 °C 5000 h
- RoHS compliance, Halogen free

Specifications

| Size code | B6 | C6 | E7 | E10 | E12 | F10 | F12 |
|------------------------------------|---|---|-----------|-----|-----------|------|------------|
| Category temp. range | -55 °C to +105 °C | | | | | | |
| Rated voltage range (V) | 16 to 25 | 16 to 50 | | 16 | 16 to 50 | 16 | 16 to 50 |
| Nominal cap.range (μ F) | 27 to 82 | 10 to 180 | 18 to 270 | 560 | 39 to 560 | 1000 | 68 to 1000 |
| Capacitance tolerance | ± 20 % (120 Hz / +20 °C) | | | | | | |
| DC leakage current | Please see the attached characteristics list | | | | | | |
| Dissipation factor (tan δ) | Please see the attached characteristics list | | | | | | |
| Endurance | +105 °C 5000 h, rated voltage applied | | | | | | |
| | Capacitance change | Within ± 20 % of the initial value | | | | | |
| | Dissipation factor (tan δ) | ≤ 150 % of the initial limit | | | | | |
| | DC leakage current | Within the initial limit | | | | | |
| Damp heat (Steady state) | +60 °C, 90 % to 95 % RH, 1000 h, No-applied voltage | | | | | | |
| | Capacitance change | Within ± 20 % of the initial value | | | | | |
| | Dissipation factor (tan δ) | ≤ 150 % of the initial limit | | | | | |
| | DC leakage current | Within the initial limit (after voltage processing) | | | | | |

Marking

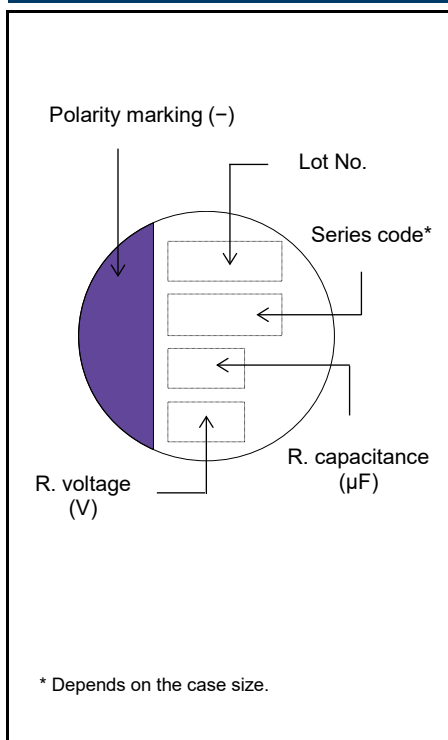

Dimensions (not to scale)

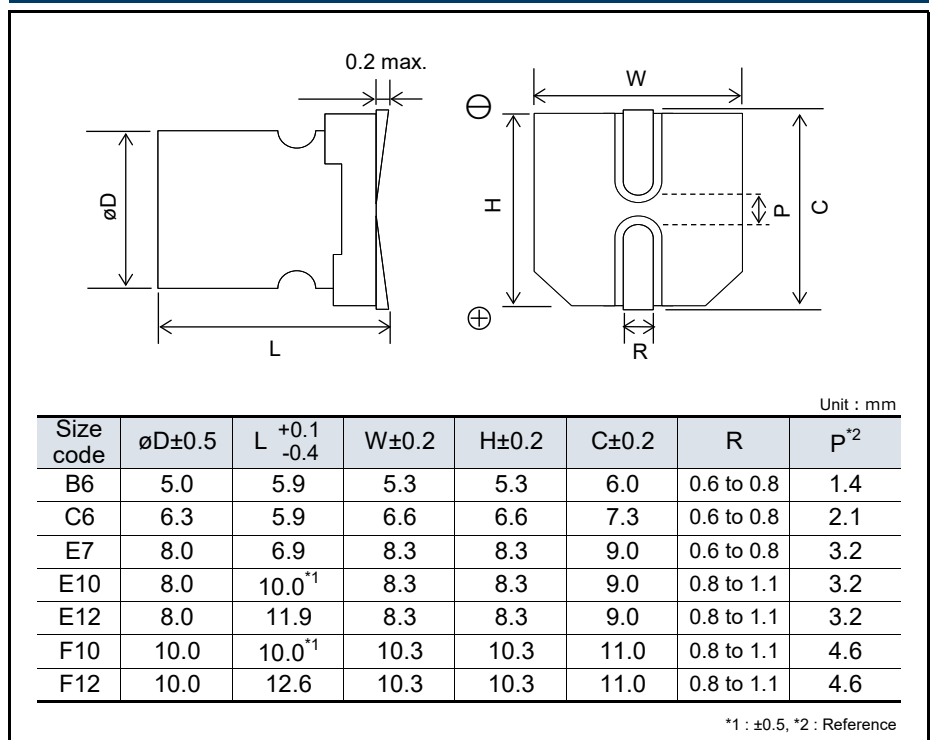

Characteristics list

| Rated voltage (V) | Rated capacitance ($\pm 20\%$) (μF) | Case size (mm) | | Size code | Specifications | | | | Standard (Reel size : $\phi 380$) | |
|-------------------|--|----------------|------|-----------|---------------------------------------|-------------------------------------|------------------------------|------------------------------------|------------------------------------|---------------------------|
| | | ϕD | L | | Ripple current* ¹ (mA rms) | ESR* ² (m Ω max.) | $\tan \delta$ * ³ | LC* ⁴ (μA) | Part number | Min. Packaging Q'ty (pcs) |
| 16 | 82 | 5.0 | 5.9 | B6 | 3000 | 27 | 0.12 | 262 | 16SVPF82M | 1500 |
| | 180 | 6.3 | 5.9 | C6 | 3300 | 22 | 0.12 | 576 | 16SVPF180M | 1000 |
| | 270 | 8.0 | 6.9 | E7 | 3300 | 22 | 0.12 | 864 | 16SVPF270M | 1000 |
| | 560 | 8.0 | 10.0 | E10 | 3900 | 18 | 0.12 | 1792 | 16SVPF560MX | 500 |
| | | 8.0 | 11.9 | E12 | 4950 | 14 | 0.12 | 1792 | 16SVPF560M | 400 |
| | 1000 | 10.0 | 10.0 | F10 | 4300 | 16 | 0.12 | 3200 | 16SVPF1000MX | 500 |
| 10.0 | | 12.6 | F12 | 5400 | 12 | 0.12 | 3200 | 16SVPF1000M | 400 | |
| 20 | 56 | 5.0 | 5.9 | B6 | 2800 | 30 | 0.12 | 224 | 20SVPF56MX | 1500 |
| | 120 | 6.3 | 5.9 | C6 | 3200 | 25 | 0.12 | 480 | 20SVPF120M | 1000 |
| | 180 | 8.0 | 6.9 | E7 | 3200 | 25 | 0.12 | 720 | 20SVPF180M | 1000 |
| | 390 | 8.0 | 11.9 | E12 | 4950 | 14 | 0.12 | 1560 | 20SVPF390M | 400 |
| | 560 | 10.0 | 12.6 | F12 | 5400 | 12 | 0.12 | 2240 | 20SVPF560M | 400 |
| 25 | 27 | 5.0 | 5.9 | B6 | 2450 | 40 | 0.12 | 135 | 25SVPF27MX | 1500 |
| | 47 | 6.3 | 5.9 | C6 | 2800 | 30 | 0.12 | 235 | 25SVPF47M | 1000 |
| | 56 | 6.3 | 5.9 | | 2800 | 30 | 0.12 | 280 | 25SVPF56M | 1000 |
| | 82 | 8.0 | 6.9 | E7 | 3000 | 28 | 0.12 | 410 | 25SVPF82M | 1000 |
| | 100 | 8.0 | 6.9 | | 3200 | 24 | 0.12 | 500 | 25SVPF100M | 1000 |
| | 180 | 8.0 | 11.9 | E12 | 4650 | 16 | 0.12 | 900 | 25SVPF180M | 400 |
| | 330 | 10.0 | 12.6 | F12 | 5000 | 14 | 0.12 | 1650 | 25SVPF330M | 400 |
| 35 | 22 | 6.3 | 5.9 | C6 | 2600 | 35 | 0.12 | 154 | 35SVPF22M | 1000 |
| | 39 | 8.0 | 6.9 | E7 | 2800 | 30 | 0.12 | 273 | 35SVPF39M | 1000 |
| | 82 | 8.0 | 11.9 | E12 | 4000 | 20 | 0.12 | 574 | 35SVPF82M | 400 |
| | 120 | 10.0 | 12.6 | F12 | 4400 | 18 | 0.12 | 840 | 35SVPF120M | 400 |
| 50 | 10 | 6.3 | 5.9 | C6 | 2500 | 40 | 0.12 | 100 | 50SVPF10M | 1000 |
| | 18 | 8.0 | 6.9 | E7 | 2700 | 35 | 0.12 | 180 | 50SVPF18M | 1000 |
| | 39 | 8.0 | 11.9 | E12 | 3800 | 25 | 0.12 | 390 | 50SVPF39M | 400 |
| | 68 | 10.0 | 12.6 | F12 | 4300 | 20 | 0.12 | 680 | 50SVPF68M | 400 |

*1: Ripple current (100 kHz / +105 °C)

*2: ESR (100 kHz to 300 kHz / +20 °C)

*3: $\tan \delta$ (120 Hz / +20 °C)

*4: After 2 minutes

◆ Please refer to each page in this catalog for "Reflow conditions" and "Taping specifications".

Frequency correction factor for ripple current

| Frequency(f) | 120 Hz \leq f < 1 kHz | 1 kHz \leq f < 10 kHz | 10 kHz \leq f < 100 kHz | 100 kHz \leq f < 500 kHz |
|--------------|-------------------------|-------------------------|---------------------------|----------------------------|
| Coefficient | 0.05 | 0.3 | 0.7 | 1 |

Conductive Polymer Aluminum
Solid Capacitors
Surface Mount Type
SVPA series

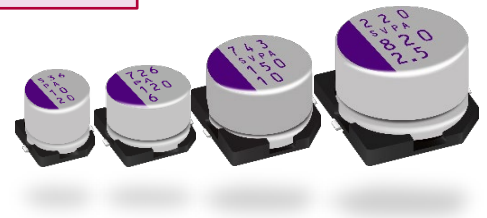

Features

- Low ESR (19 mΩ max.)
- High ripple (4240 mA rms)
- RoHS compliance, Halogen free

Specifications

| Size code | B6 | C6 | E7 | F8 |
|----------------------------|---|---|-----------------|------------------|
| Category temp. range | -55 °C to +105 °C | | | |
| Rated voltage range | 2.5 V to 20 V | | | 2.5 V to 16 V |
| Nominal cap.range | 10 μF to 82 μF | 22 μF to 180 μF | 47 μF to 330 μF | 180 μF to 820 μF |
| Capacitance tolerance | ±20 % (120 Hz / +20 °C) | | | |
| DC leakage current | Please see the attached characteristics list | | | |
| Dissipation factor (tan δ) | Please see the attached characteristics list | | | |
| Endurance | +105 °C 2000 h, rated voltage applied | | | |
| | Capacitance change | Within ±20 % of the initial value | | |
| | Dissipation factor (tanδ) | ≤ 150 % of the initial limit | | |
| | DC leakage current | Within the initial limit | | |
| Damp heat (Steady state) | +60 °C, 90 % to 95 % RH, 1000 h, No-applied voltage | | | |
| | Capacitance change | Within ±20 % of the initial value | | |
| | Dissipation factor (tanδ) | ≤ 150 % of the initial limit | | |
| | DC leakage current | Within the initial limit (after voltage processing) | | |

Marking

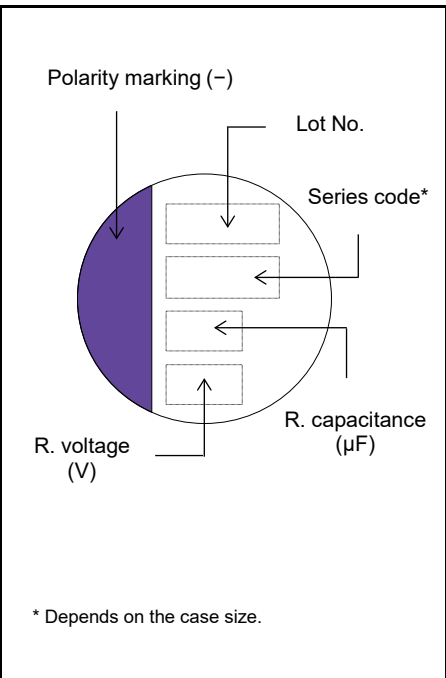

Dimensions (not to scale)

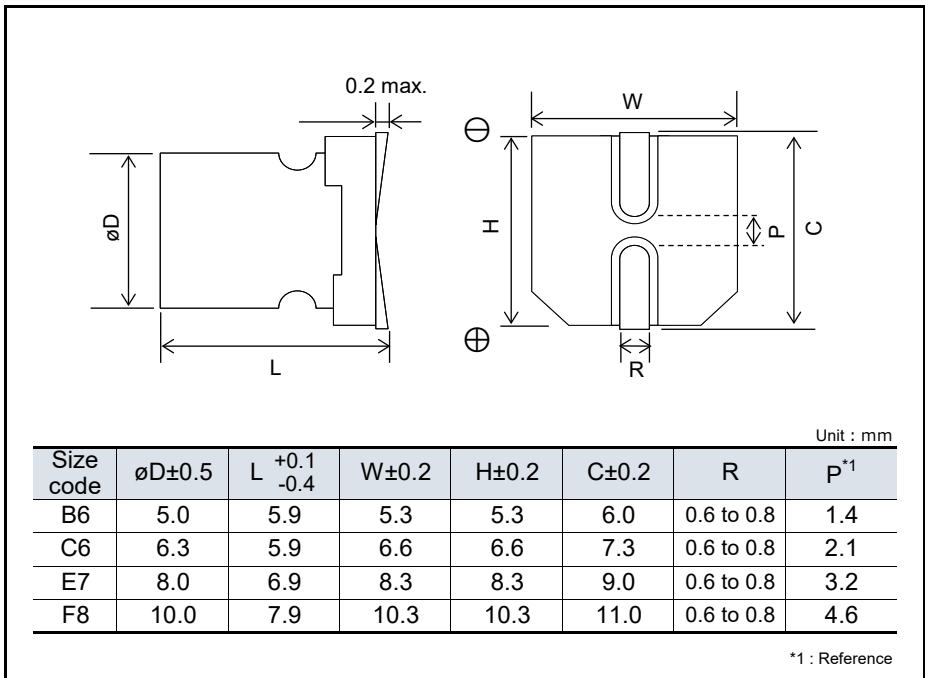

Characteristics list

| Rated voltage (V) | Rated capacitance (±20 %) (μF) | Case size (mm) | | Size code | Specifications | | | | Standard (Reel size : ø380) | |
|-------------------|--------------------------------|----------------|-----|-----------|---------------------------------------|-----------------------------|---------------------|-----------------------|-----------------------------|--------------------------|
| | | øD | L | | Ripple current* ¹ (mA rms) | ESR* ² (mΩ max.) | tan δ* ³ | LC* ⁴ (μA) | Part number | Min. Packaging Qty (pcs) |
| 2.5 | NRFND 82 | 5.0 | 5.9 | B6 | 1970 | 30 | 0.12 | 300 | 2R5SVPA82MAA | 1500 |
| | NRFND 180 | 6.3 | 5.9 | C6 | 2690 | 20 | 0.12 | 300 | 2R5SVPA180MAA | 1000 |
| | NRFND 330 | 8.0 | 6.9 | E7 | 3370 | 20 | 0.12 | 500 | 2R5SVPA330MAA | 1000 |
| | 820 | 10.0 | 7.9 | F8 | 4240 | 19 | 0.12 | 500 | 2R5SVPA820M | 500 |
| 4.0 | NRFND 68 | 5.0 | 5.9 | B6 | 1970 | 30 | 0.12 | 300 | 4SVPA68MAA | 1500 |
| | NRFND 150 | 6.3 | 5.9 | C6 | 2570 | 22 | 0.12 | 300 | 4SVPA150MAA | 1000 |
| | 270 | 8.0 | 6.9 | E7 | 3220 | 22 | 0.12 | 500 | 4SVPA270MAA | 1000 |
| | 680 | 10.0 | 7.9 | F8 | 4130 | 20 | 0.12 | 544 | 4SVPA680M | 500 |
| 6.3 | 47 | 5.0 | 5.9 | B6 | 1970 | 30 | 0.12 | 300 | 6SVPA47MAA | 1500 |
| | 120 | 6.3 | 5.9 | C6 | 2570 | 22 | 0.12 | 300 | 6SVPA120MAA | 1000 |
| | 220 | 8.0 | 6.9 | E7 | 3220 | 22 | 0.12 | 500 | 6SVPA220MAA | 1000 |
| | 470 | 10.0 | 7.9 | F8 | 4130 | 20 | 0.12 | 592 | 6SVPA470M | 500 |
| 10 | 68 | 6.3 | 5.9 | C6 | 2200 | 30 | 0.12 | 300 | 10SVPA68MAA | 1000 |
| | 150 | 8.0 | 6.9 | E7 | 2760 | 30 | 0.12 | 500 | 10SVPA150MAA | 1000 |
| | 330 | 10.0 | 7.9 | F8 | 3770 | 24 | 0.12 | 660 | 10SVPA330M | 500 |
| 16 | 39 | 6.3 | 5.9 | C6 | 2040 | 35 | 0.12 | 300 | 16SVPA39MAA | 1000 |
| | | 6.3 | 5.9 | | 2460 | 24 | 0.12 | 300 | 16SVPA39MAAY | 1000 |
| | 82 | 8.0 | 6.9 | E7 | 2760 | 30 | 0.12 | 262 | 16SVPA82MAA | 1000 |
| | 180 | 10.0 | 7.9 | F8 | 3430 | 29 | 0.12 | 576 | 16SVPA180M | 500 |
| 20 | 10 | 5.0 | 5.9 | B6 | 1700 | 40 | 0.12 | 80 | 20SVPA10M | 1500 |
| | 22 | 6.3 | 5.9 | C6 | 2040 | 35 | 0.12 | 88 | 20SVPA22M | 1000 |
| | 47 | 8.0 | 6.9 | E7 | 2630 | 33 | 0.12 | 188 | 20SVPA47M | 1000 |

*1: Ripple current (100 kHz / +105 °C)

NRFND

Not recommended for new design

*2: ESR (100 kHz / +20 °C)

*3: tan δ (120 Hz / +20 °C)

*4: After 2 minutes

◆ Please refer to each page in this catalog for "Reflow conditions" and "Taping specifications".

Frequency correction factor for ripple current

| Frequency(f) | 120 Hz ≤ f < 1 kHz | 1 kHz ≤ f < 10 kHz | 10 kHz ≤ f < 100 kHz | 100 kHz ≤ f < 500 kHz |
|--------------|--------------------|--------------------|----------------------|-----------------------|
| Coefficient | 0.05 | 0.3 | 0.7 | 1 |

**Conductive Polymer Aluminum
Solid Capacitors**
Surface Mount Type
SVPC series

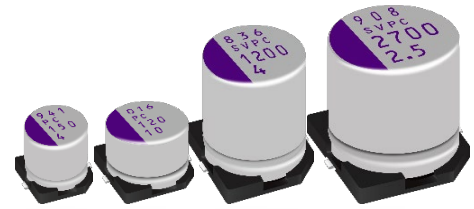

Features

- Low ESR (9 mΩ max.)
- Large capacitance (2700 μF max.)
- RoHS compliance, Halogen free

Specifications

| Size code | B6 | C6 | E7 | E12 | F12 |
|----------------------------|---|-----------------------------------|------------------|-------------------|---|
| Category temp. range | -55 °C to +105 °C | | | | |
| Rated voltage range | 2.5 V to 16 V | | | | 2.5 V |
| Nominal cap.range | 39 μF to 180 μF | 68 μF to 560 μF | 120 μF to 680 μF | 270 μF to 1500 μF | 2700 μF |
| Capacitance tolerance | ±20 % (120 Hz / +20 °C) | | | | |
| DC leakage current | Please see the attached characteristics list | | | | |
| Dissipation factor (tan δ) | Please see the attached characteristics list | | | | |
| Endurance | +105 °C 2000 h, rated voltage applied | | | | |
| | Capacitance change | Within ±20 % of the initial value | | | |
| | Dissipation factor (tanδ) | ≤ 150 % of the initial limit | | | |
| Damp heat (Steady state) | +60 °C, 90 % to 95 % RH, 1000 h, No-applied voltage | | | | |
| | Capacitance change | Within ±20 % of the initial value | | | |
| | Dissipation factor (tanδ) | ≤ 150 % of the initial limit | | | |
| | DC leakage current | | | | Within the initial limit (after voltage processing) |

Marking

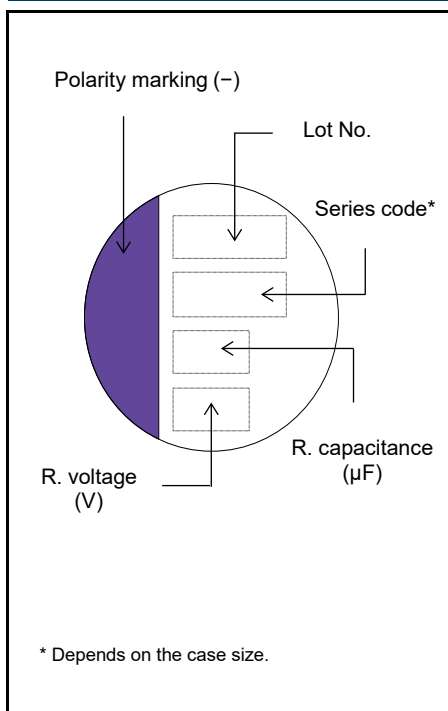

Dimensions (not to scale)

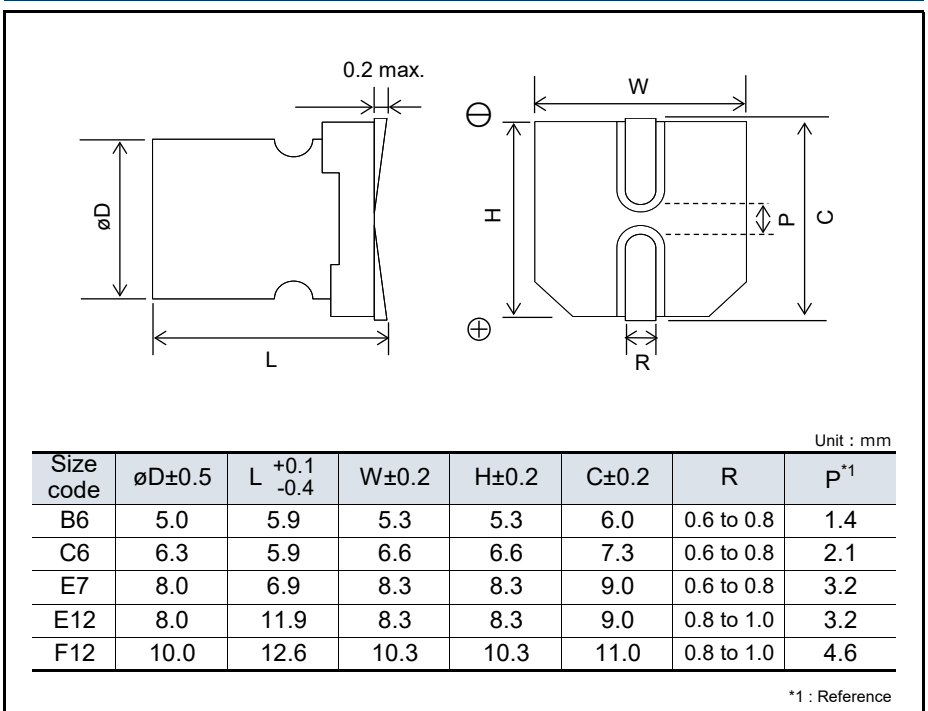

Characteristics list

| Rated voltage (V) | Rated capacitance ($\pm 20\%$) (μF) | Case size (mm) | | Size code | Specifications | | | | | Standard (Reel size : $\phi 380$) | |
|-------------------|--|----------------|------|-----------|---------------------------------------|-----------------------|-------------------------------|-----------------------------|------------------------------------|------------------------------------|--------------------------|
| | | ϕD | L | | Ripple current ^{*1} (mA rms) | ESR (m Ω max.) | | $\tan \delta$ ^{*3} | LC ^{*4} (μA) | Part number | Min. Packaging Qty (pcs) |
| | | | | | | 100 kHz / 20 °C | 300 kHz ^{*2} / 20 °C | | | | |
| 2.5 | 180 | 5.0 | 5.9 | B6 | 1970 | 30 | 26 | 0.12 | 300 | 2R5SVPC180M | 1500 |
| | | 5.0 | 5.9 | | 2200 | 24 | 20 | 0.12 | 300 | 2R5SVPC180MY | 1500 |
| | | 5.0 | 5.9 | | 2800 | 19 | 16 | 0.12 | 300 | 2R5SVPC180MV | 1500 |
| | 390 | 6.3 | 5.9 | C6 | 2410 | 25 | 22 | 0.12 | 300 | 2R5SVPC390M | 1000 |
| | | 6.3 | 5.9 | | 3160 | 15 | 13 | 0.12 | 300 | 2R5SVPC390MV | 1000 |
| | | 6.3 | 5.9 | | 3500 | 16 | 14 | 0.12 | 300 | 2R5SVPC560M | 1000 |
| | 680 | 8.0 | 6.9 | E7 | 3370 | 20 | 17 | 0.12 | 500 | 2R5SVPC680M | 1000 |
| | 820 | 8.0 | 11.9 | E12 | 5380 | 9 | 8 | 0.15 | 500 | 2R5SVPC820M | 400 |
| | 1500 | 8.0 | 11.9 | | 5150 | 10 | 9 | 0.15 | 750 | 2R5SVPC1500M | 400 |
| 2700 | 10.0 | 12.6 | F12 | 5070 | 12 | 10 | 0.15 | 1350 | 2R5SVPC2700M | 400 | |
| 4.0 | 150 | 5.0 | 5.9 | B6 | 1970 | 30 | 26 | 0.12 | 300 | 4SVPC150M | 1500 |
| | | 5.0 | 5.9 | | 2240 | 23 | 20 | 0.12 | 300 | 4SVPC150MY | 1500 |
| | | 5.0 | 5.9 | | 2730 | 20 | 17 | 0.12 | 300 | 4SVPC150MV | 1500 |
| | 330 | 6.3 | 5.9 | C6 | 2320 | 27 | 23 | 0.12 | 300 | 4SVPC330M | 1000 |
| | | 6.3 | 5.9 | | 2630 | 21 | 18 | 0.12 | 300 | 4SVPC330MY | 1000 |
| | | 6.3 | 5.9 | | 3160 | 15 | 13 | 0.12 | 300 | 4SVPC330MV | 1000 |
| | 560 | 8.0 | 6.9 | E7 | 3220 | 22 | 19 | 0.12 | 500 | 4SVPC560M | 1000 |
| | | 8.0 | 11.9 | E12 | 5380 | 9 | 8 | 0.15 | 500 | 4SVPC560MX | 400 |
| | 1200 | 8.0 | 11.9 | | 4700 | 12 | 10 | 0.15 | 960 | 4SVPC1200M | 400 |
| 1500 | 8.0 | 11.9 | 4700 | | 12 | 10 | 0.15 | 1200 | 4SVPC1500M | 400 | |
| 6.3 | 100 | 5.0 | 5.9 | B6 | 1970 | 30 | 26 | 0.12 | 300 | 6SVPC100M | 1500 |
| | | 5.0 | 5.9 | | 2150 | 25 | 21 | 0.12 | 300 | 6SVPC100MY | 1500 |
| | 120 | 5.0 | 5.9 | C6 | 2660 | 21 | 18 | 0.12 | 300 | 6SVPC120MV | 1500 |
| | 220 | 6.3 | 5.9 | | 2320 | 27 | 23 | 0.12 | 300 | 6SVPC220M | 1000 |
| | | 6.3 | 5.9 | | 3160 | 15 | 13 | 0.12 | 300 | 6SVPC220MV | 1000 |
| | 330 | 6.3 | 5.9 | 3390 | 17 | 15 | 0.12 | 415 | 6SVPC330M | 1000 | |
| | 390 | 8.0 | 6.9 | E7 | 3220 | 22 | 19 | 0.12 | 491 | 6SVPC390M | 1000 |
| | 820 | 8.0 | 11.9 | E12 | 4700 | 12 | 10 | 0.15 | 1033 | 6SVPC820M | 400 |
| 10 | 68 | 5.0 | 5.9 | B6 | 1970 | 30 | 26 | 0.12 | 300 | 10SVPC68M | 1500 |
| | | 5.0 | 5.9 | | 2540 | 23 | 20 | 0.12 | 300 | 10SVPC68MV | 1500 |
| | 120 | 6.3 | 5.9 | C6 | 2320 | 27 | 23 | 0.12 | 300 | 10SVPC120M | 1000 |
| | | 6.3 | 5.9 | | 2600 | 22 | 19 | 0.12 | 300 | 10SVPC120MV | 1000 |
| | 270 | 8.0 | 6.9 | E7 | 3220 | 22 | 19 | 0.12 | 500 | 10SVPC270M | 1000 |
| 330 | 8.0 | 6.9 | E7 | 3460 | 19 | 17 | 0.12 | 660 | 10SVPC330M | 1000 | |
| 16 | 39 | 5.0 | 5.9 | B6 | 1820 | 35 | 30 | 0.12 | 300 | 16SVPC39M | 1500 |
| | | 5.0 | 5.9 | | 2350 | 27 | 23 | 0.12 | 300 | 16SVPC39MV | 1500 |
| | 68 | 6.3 | 5.9 | C6 | 2200 | 30 | 26 | 0.12 | 300 | 16SVPC68M | 1000 |
| | | 6.3 | 5.9 | | 2440 | 25 | 22 | 0.12 | 300 | 16SVPC68MV | 1000 |
| | 100 | 6.3 | 5.9 | 2490 | 24 | 23 | 0.12 | 300 | 16SVPC100M | 1000 | |
| | 120 | 8.0 | 6.9 | E7 | 2900 | 27 | 23 | 0.12 | 500 | 16SVPC120M | 1000 |
| | 150 | 8.0 | 6.9 | | 3220 | 22 | 21 | 0.12 | 500 | 16SVPC150M | 1000 |
| | 270 | 8.0 | 11.9 | | E12 | 4070 | 16 | 14 | 0.15 | 864 | 16SVPC270M |

*1: Ripple current (100 kHz / +105 °C) *2: Reference value at 300 kHz *3: $\tan \delta$ (120 Hz / +20 °C) *4: After 2 minutes

◆ Please refer to each page in this catalog for "Reflow conditions" and "Taping specifications".

Frequency correction factor for ripple current

| Frequency(f) | 120 Hz \leq f < 1 kHz | 1 kHz \leq f < 10 kHz | 10 kHz \leq f < 100 kHz | 100 kHz \leq f < 500 kHz |
|--------------|-------------------------|-------------------------|---------------------------|----------------------------|
| Coefficient | 0.05 | 0.3 | 0.7 | 1 |

Design and specifications are each subject to change without notice. Ask factory for the current technical specifications before purchase and/or use.
Should a safety concern arise regarding this product, please be sure to contact us immediately.

06-Feb-17

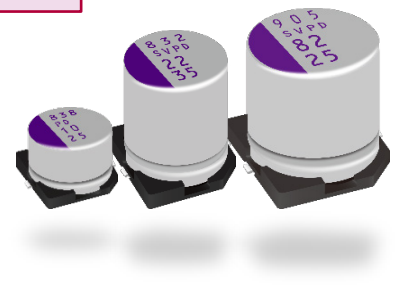

Conductive Polymer Aluminum Solid Capacitors

Surface Mount Type

SVPD series

Features

- 125 °C 2000 h
- Guaranteed at 85 °C 85 %
- RoHS compliance, Halogen free

Specifications

| Size code | C6 | E7 | E12 | F8 | F12 |
|----------------------------|---|-----------------------------------|----------------|----------------|---|
| Category temp. range | -55 °C to +125 °C | | | | |
| Rated voltage range | 10 V to 25 V | 16 V to 35 V | 25 V to 35 V | | |
| Nominal cap.range | 10 μF to 56 μF | 8.2 μF to 82 μF | 22 μF to 47 μF | 18 μF to 39 μF | 47 μF to 82 μF |
| Capacitance tolerance | ±20 % (120 Hz / +20 °C) | | | | |
| DC leakage current | Please see the attached characteristics list | | | | |
| Dissipation factor (tan δ) | Please see the attached characteristics list | | | | |
| Endurance | +125 °C 2000 h, rated voltage applied | | | | |
| | Capacitance change | Within ±20 % of the initial value | | | |
| | Dissipation factor (tanδ) | ≤ 200 % of the initial limit | | | |
| Damp heat (Steady state) | +85 °C, 80 % to 90 % RH, 1000 h, rated voltage applied. | | | | |
| | Capacitance change | Within ±20 % of the initial value | | | |
| | Dissipation factor (tanδ) | ≤ 200 % of the initial limit | | | |
| | DC leakage current | | | | Within the initial limit (after voltage processing) |

Marking

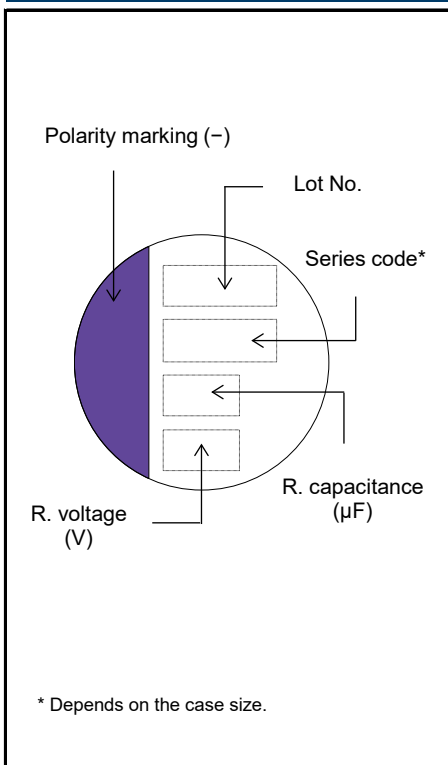

Dimensions (not to scale)

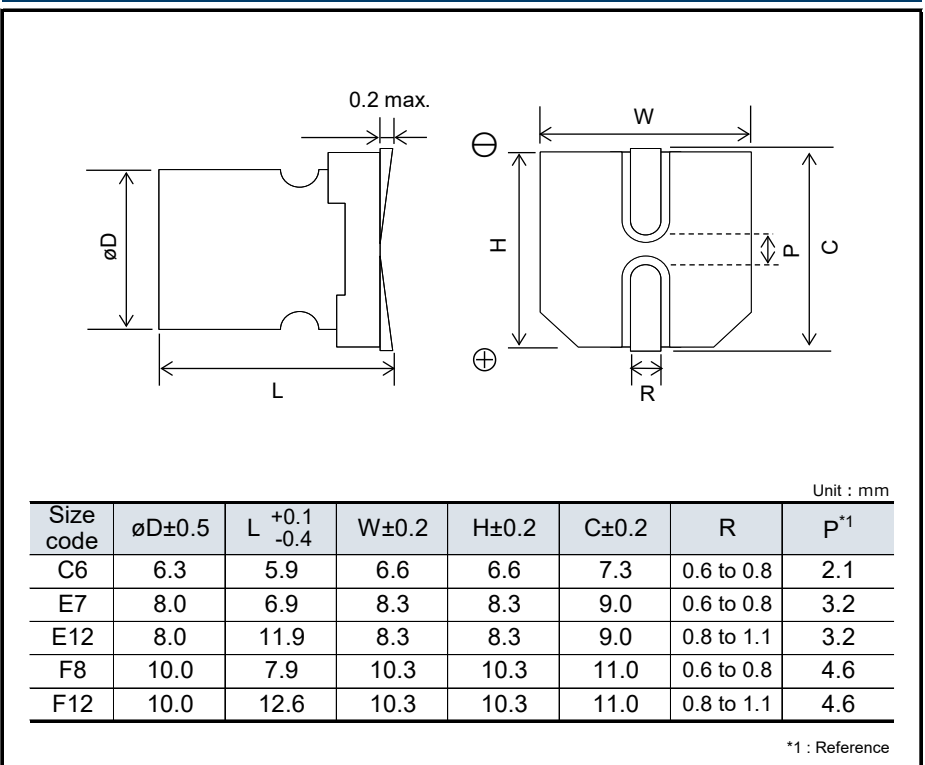

Characteristics list

| Rated voltage (V) | Rated capacitance ($\pm 20\%$) (μF) | Case size (mm) | | Size code | Specifications | | | | | Standard (Reel size : $\phi 380$) | |
|-------------------|--|----------------|------|-----------|---------------------------------------|---|-------------------------------------|------------------------------|------------------------------------|------------------------------------|---------------------------|
| | | ϕD | L | | Ripple current* ¹ (mA rms) | Allowable ripple current* ¹ (mA rms) | ESR* ² (m Ω max.) | $\tan \delta$ * ³ | LC* ⁴ (μA) | Part number | Min. Packaging Q'ty (pcs) |
| 10 | 56 | 6.3 | 5.9 | C6 | 538 | 1700 | 45 | 0.12 | 112 | 10SVPD56M | 1000 |
| 16 | 82 | 8.0 | 6.9 | E7 | 670 | 2120 | 40 | 0.12 | 262 | 16SVPD82M | 1000 |
| 25 | 10 | 6.3 | 5.9 | C6 | 474 | 1500 | 65 | 0.10 | 50 | 25SVPD10M | 1000 |
| | 22 | 8.0 | 6.9 | E7 | 580 | 1835 | 48 | 0.10 | 110 | 25SVPD22M | 1000 |
| | 39 | 10.0 | 7.9 | F8 | 664 | 2100 | 45 | 0.10 | 195 | 25SVPD39M | 500 |
| | 47 | 8.0 | 11.9 | E12 | 943 | 2980 | 30 | 0.12 | 235 | 25SVPD47M | 400 |
| | 82 | 10.0 | 12.6 | F12 | 1202 | 3800 | 28 | 0.12 | 410 | 25SVPD82M | 400 |
| 35 | NRFND 8.2 | 8.0 | 6.9 | E7 | 400 | 1300 | 70 | 0.10 | 57 | 35SVPD8R2M | 1000 |
| | 18 | 10.0 | 7.9 | F8 | 550 | 1800 | 60 | 0.10 | 126 | 35SVPD18M | 500 |
| | 22 | 8.0 | 11.9 | E12 | 700 | 2300 | 50 | 0.12 | 154 | 35SVPD22M | 400 |
| | 47 | 10.0 | 12.6 | F12 | 1150 | 3650 | 30 | 0.12 | 329 | 35SVPD47M | 400 |

*1: Ripple current (100 kHz / $+105\text{ }^\circ\text{C} < \text{T}_x \leq +125\text{ }^\circ\text{C}$), Allowable ripple current (100 kHz / $\text{T}_x \leq +105\text{ }^\circ\text{C}$)

*2: ESR (100 kHz to 300 kHz / $+20\text{ }^\circ\text{C}$)

NRFND Not recommended for new design

*3: $\tan \delta$ (120 Hz / $+20\text{ }^\circ\text{C}$)

*4: After 2 minutes

◆ Please refer to each page in this catalog for "Reflow conditions" and "Taping specifications".

Frequency correction factor for ripple current

| Frequency(f) | $120\text{ Hz} \leq f < 1\text{ kHz}$ | $1\text{ kHz} \leq f < 10\text{ kHz}$ | $10\text{ kHz} \leq f < 100\text{ kHz}$ | $100\text{ kHz} \leq f < 500\text{ kHz}$ |
|--------------|---------------------------------------|---------------------------------------|---|--|
| Coefficient | 0.05 | 0.3 | 0.7 | 1 |

**Conductive Polymer Aluminum
Solid Capacitors**
Surface Mount Type
SVPE series

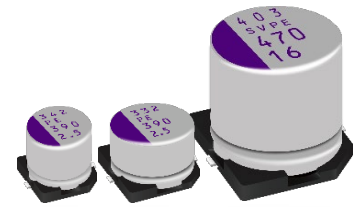

Features

- Low ESR (8 mΩ max.)
- Large capacitance (1200 μF max.)
- RoHS compliance, Halogen free

Specifications

| Size code | B6 | C6 | C10 | F12 |
|----------------------------|---|---|-------------------|--------|
| Category temp. range | -55 °C to +105 °C | | | |
| Rated voltage range | 2.5 V to 6.3 V | 2.5 V to 10 V | 2.0 V to 16 V | 16 V |
| Nominal cap.range | 150 μF to 390 μF | 220 μF to 820 μF | 180 μF to 1200 μF | 470 μF |
| Capacitance tolerance | ±20 % (120 Hz / +20 °C) | | | |
| DC leakage current | Please see the attached characteristics list | | | |
| Dissipation factor (tan δ) | Please see the attached characteristics list | | | |
| Endurance | +105 °C 2000 h, rated voltage applied | | | |
| | Capacitance change | Within ±20 % of the initial value | | |
| | Dissipation factor (tanδ) | ≤ 150 % of the initial limit | | |
| Damp heat (Steady state) | +60 °C, 90 % to 95 % RH, 1000 h, No-applied voltage | | | |
| | Capacitance change | Within ±20 % of the initial value | | |
| | Dissipation factor (tanδ) | ≤ 150 % of the initial limit | | |
| | DC leakage current | Within the initial limit (after voltage processing) | | |

Marking

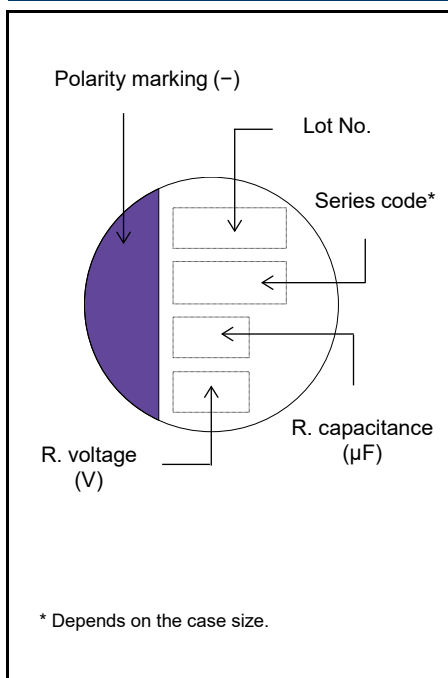

Dimensions (not to scale)

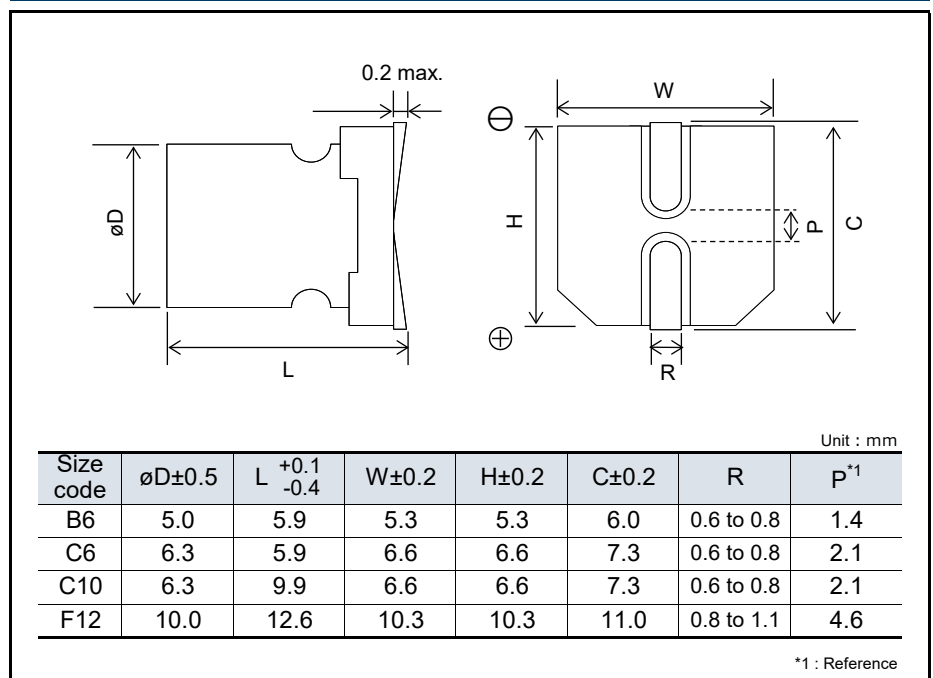

Characteristics list

| Rated voltage (V) | Rated capacitance ($\pm 20\%$) (μF) | Case size (mm) | | Size code | Specifications | | | | | Standard (Reel size : $\phi 380$) | |
|-------------------|--|----------------|------|-----------|---------------------------------------|-----------------------|-------------------------------|-----------------------------|------------------------------------|------------------------------------|--------------------------|
| | | ϕD | L | | Ripple current ^{*1} (mA rms) | ESR (m Ω max.) | | $\tan \delta$ ^{*3} | LC ^{*4} (μA) | Part number | Min. Packaging Qty (pcs) |
| | | | | | | 100 kHz / 20 °C | 300 kHz ^{*2} / 20 °C | | | | |
| 2.0 | 1200 | 6.3 | 9.9 | C10 | 5230 | 8 | 8 | 0.12 | 500 | 2SVPE1200M | 500 |
| 2.5 | 270 | 5.0 | 5.9 | B6 | 3860 | 10 | 9 | 0.12 | 500 | 2R5SVPE270M | 1500 |
| | 330 | 5.0 | 5.9 | | 3150 | 15 | 13 | 0.12 | 500 | 2R5SVPE330M | 1500 |
| | | 5.0 | 5.9 | | 3860 | 10 | 9 | 0.12 | 500 | 2R5SVPE330MY | 1500 |
| | 390 | 5.0 | 5.9 | | 3860 | 10 | 9 | 0.12 | 700 | 2R5SVPE390MX | 1500 |
| | | 6.3 | 5.9 | C6 | 3900 | 10 | 9 | 0.12 | 500 | 2R5SVPE390M | 1000 |
| | 820 | 6.3 | 5.9 | 3900 | 10 | 9 | 0.12 | 1020 | 2R5SVPE820M | 1000 | |
| 6.3 | 150 | 5.0 | 5.9 | B6 | 3520 | 12 | 10 | 0.12 | 500 | 6SVPE150M | 1500 |
| | 180 | 5.0 | 5.9 | | 3150 | 15 | 13 | 0.12 | 500 | 6SVPE180M | 1500 |
| | 220 | 5.0 | 5.9 | | 3150 | 15 | 13 | 0.12 | 500 | 6SVPE220MW | 1500 |
| | | 6.3 | 5.9 | C6 | 3900 | 10 | 9 | 0.12 | 500 | 6SVPE220M | 1000 |
| | 390 | 6.3 | 5.9 | 3900 | 10 | 9 | 0.12 | 1220 | 6SVPE390M | 1000 | |
| 10 | 220 | 6.3 | 5.9 | | 2700 | 20 | 18 | 0.12 | 500 | 10SVPE220M | 1000 |
| 16 | 180 | 6.3 | 9.9 | C10 | 4460 | 11 | 10 | 0.12 | 576 | 16SVPE180M | 500 |
| | 470 | 10.0 | 12.6 | F12 | 6100 | 10 | 9 | 0.12 | 1504 | 16SVPE470M | 400 |

*1: Ripple current (100 kHz / +105 °C)

*2: Reference value at 300 kHz

*3: $\tan \delta$ (120 Hz / +20 °C)

*4: After 2 minutes

◆ Please refer to each page in this catalog for "Reflow conditions" and "Taping specifications".

Frequency correction factor for ripple current

| Frequency(f) | 120 Hz \leq f < 1 kHz | 1 kHz \leq f < 10 kHz | 10 kHz \leq f < 100 kHz | 100 kHz \leq f < 500 kHz |
|--------------|-------------------------|-------------------------|---------------------------|----------------------------|
| Coefficient | 0.05 | 0.3 | 0.7 | 1 |

Conductive Polymer Aluminum Solid Capacitors

Surface Mount Type

SVPS series



Features

- 105 °C 5000 h
- RoHS compliance, Halogen free

Specifications

| Size code | A5 | B6 | C6 | E7 | F8 |
|-----------------------------|---|---|-----------------|-----------------|------------------|
| Category temp. range | -55 °C to +105 °C | | | | |
| Rated voltage range | 4.0 V to 10 V | 4.0 V to 16 V | 4.0 V to 20 V | 4.0 V to 25 V | 4.0 V to 16 V |
| Nominal cap.range | 10 μF to 33 μF | 22 μF to 68 μF | 22 μF to 150 μF | 10 μF to 270 μF | 100 μF to 680 μF |
| Capacitance tolerance | ±20 % (120 Hz / +20 °C) | | | | |
| DC leakage current | Please see the attached characteristics list | | | | |
| Dissipation factor (tan δ) | Please see the attached characteristics list | | | | |
| Endurance | +105 °C 5000 h, rated voltage applied (25 V product : 20 V applied) | | | | |
| | Capacitance change | Within ±20 % of the initial value | | | |
| | Dissipation factor (tanδ) | ≤ 150 % of the initial limit | | | |
| | DC leakage current | Within the initial limit | | | |
| Damp heat (Steady state) | +60 °C, 90 % to 95 % RH, 1000 h, No-applied voltage | | | | |
| | Capacitance change | Within ±20 % of the initial value | | | |
| | Dissipation factor (tanδ) | ≤ 150 % of the initial limit | | | |
| | DC leakage current | Within the initial limit (after voltage processing) | | | |

Marking

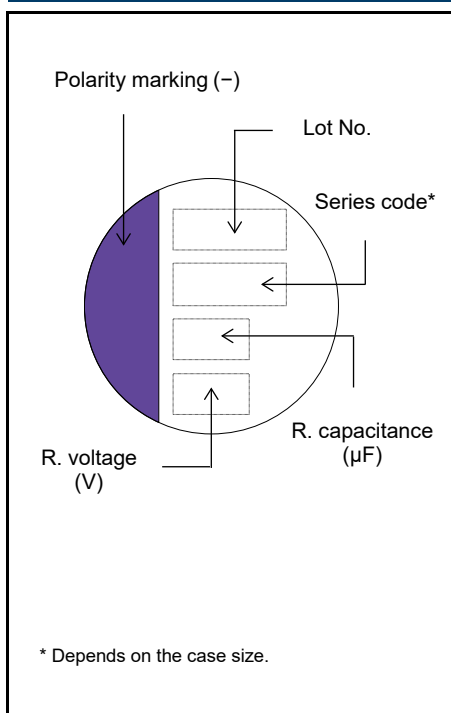

Dimensions (not to scale)

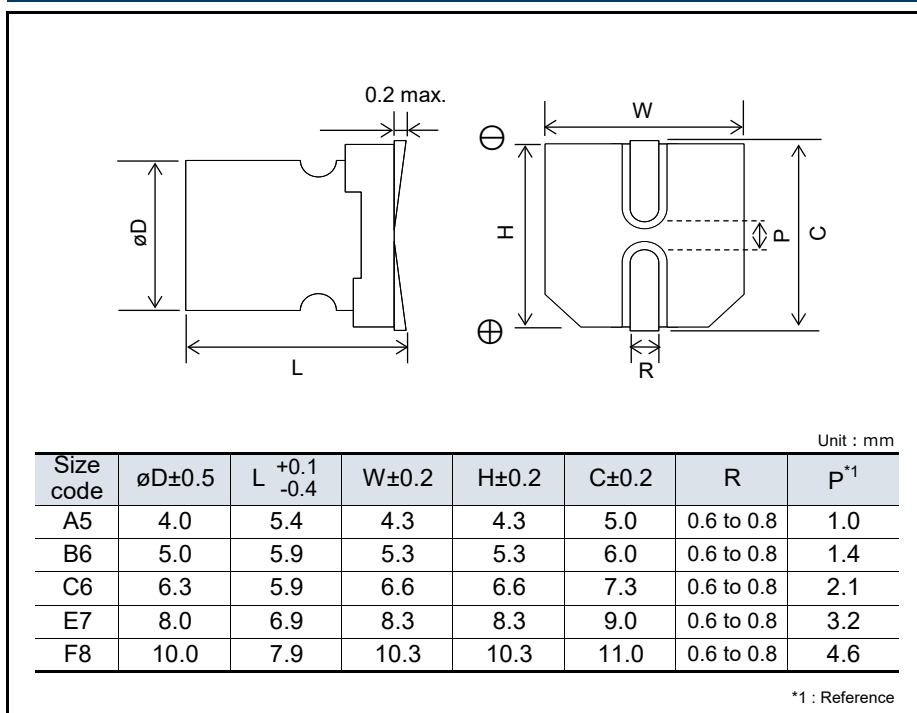

Characteristics list

| Rated voltage (V) | Rated capacitance (±20 %) (μF) | Case size (mm) | | Size code | Specifications | | | | Standard (Reel size : ø380) | |
|-------------------|--------------------------------|----------------|------|-----------|---------------------------------------|-----------------------------|---------------------|-----------------------|-----------------------------|--------------------------|
| | | øD | L | | Ripple current* ¹ (mA rms) | ESR* ² (mΩ max.) | tan δ* ³ | LC* ⁴ (μA) | Part number | Min. Packaging Qty (pcs) |
| 4.0 | NRFND 33 | 4.0 | 5.4 | A5 | 740 | 200 | 0.15 | 66 | 4SVPS33M | 2000 |
| | NRFND 68 | 5.0 | 5.9 | B6 | 1970 | 30 | 0.12 | 300 | 4SVPS68M | 1500 |
| | 150 | 6.3 | 5.9 | C6 | 2570 | 22 | 0.12 | 300 | 4SVPS150M | 1000 |
| | NRFND 270 | 8.0 | 6.9 | E7 | 3220 | 22 | 0.12 | 500 | 4SVPS270M | 1000 |
| | 680 | 10.0 | 7.9 | F8 | 4130 | 20 | 0.12 | 544 | 4SVPS680M | 500 |
| 6.3 | NRFND 22 | 4.0 | 5.4 | A5 | 740 | 200 | 0.12 | 69.3 | 6SVPS22M | 2000 |
| | 47 | 5.0 | 5.9 | B6 | 1970 | 30 | 0.12 | 300 | 6SVPS47M | 1500 |
| | 120 | 6.3 | 5.9 | C6 | 2570 | 22 | 0.12 | 300 | 6SVPS120M | 1000 |
| | 220 | 8.0 | 6.9 | E7 | 3220 | 22 | 0.12 | 500 | 6SVPS220M | 1000 |
| | 470 | 10.0 | 7.9 | F8 | 4130 | 20 | 0.12 | 592 | 6SVPS470M | 500 |
| 10 | NRFND 10 | 4.0 | 5.4 | A5 | 700 | 220 | 0.10 | 50 | 10SVPS10M | 2000 |
| | NRFND 15 | 4.0 | 5.4 | | 740 | 200 | 0.10 | 75 | 10SVPS15M | 2000 |
| | 33 | 5.0 | 5.9 | B6 | 1100 | 70 | 0.12 | 165 | 10SVPS33M | 1500 |
| | 68 | 6.3 | 5.9 | C6 | 2200 | 30 | 0.12 | 300 | 10SVPS68M | 1000 |
| | 150 | 8.0 | 6.9 | F8 | 2760 | 30 | 0.12 | 500 | 10SVPS150MX | 1000 |
| | | 10.0 | 7.9 | | 3020 | 30 | 0.12 | 300 | 10SVPS150M | 500 |
| | 330 | 10.0 | 7.9 | | 3770 | 24 | 0.12 | 660 | 10SVPS330M | 500 |
| 16 | 22 | 5.0 | 5.9 | B6 | 1060 | 90 | 0.10 | 176 | 16SVPS22M | 1500 |
| | 39 | 6.3 | 5.9 | C6 | 2460 | 24 | 0.12 | 300 | 16SVPS39M | 1000 |
| | 82 | 8.0 | 6.9 | E7 | 2760 | 30 | 0.12 | 262 | 16SVPS82M | 1000 |
| | 100 | 10.0 | 7.9 | F8 | 2670 | 35 | 0.12 | 320 | 16SVPS100M | 500 |
| | | 180 | 10.0 | | 7.9 | 3430 | 29 | 0.12 | 576 | 16SVPS180M |
| 20 | 22 | 6.3 | 5.9 | C6 | 1450 | 60 | 0.10 | 88 | 20SVPS22M | 1000 |
| | 47 | 8.0 | 6.9 | E7 | 1890 | 45 | 0.12 | 188 | 20SVPS47M | 1000 |
| 25 | 10 | 8.0 | 6.9 | E7 | 1500 | 60 | 0.10 | 125 | 25SVPS10M | 1000 |

*1: Ripple current (100 kHz / +105 °C)

NRFND

Not recommended for new design

: The surface temperature of aluminum case top must not exceed 105 °C.

A rise in temperature due to self-heating by ripple current should be factored in.

*2: ESR (100 kHz to 300 kHz / +20 °C)

*3: tan δ (120 Hz / +20 °C)

*4: After 2 minutes

◆ Please refer to each page in this catalog for "Reflow conditions" and "Taping specifications".

Frequency correction factor for ripple current

| Frequency(f) | 120 Hz ≤ f < 1 kHz | 1 kHz ≤ f < 10 kHz | 10 kHz ≤ f < 100 kHz | 100 kHz ≤ f < 500 kHz |
|--------------|--------------------|--------------------|----------------------|-----------------------|
| Coefficient | 0.05 | 0.3 | 0.7 | 1 |



Conductive Polymer Aluminum Solid Capacitors

Surface Mount Type

SVQP series

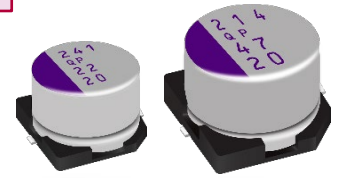

Features

- 125 °C 1000 h
- RoHS compliance, Halogen free

Specifications

| Size code | C6 | E7 |
|----------------------------|---|---|
| Category temp. range | -55 °C to +125 °C | |
| Rated voltage range | 4.0 V to 20 V | 6.3 V to 20 V |
| Nominal cap.range | 22 μF to 150 μF | 47 μF to 220 μF |
| Capacitance tolerance | ±20 % (120 Hz / +20 °C) | |
| DC leakage current | Please see the attached characteristics list | |
| Dissipation factor (tan δ) | Please see the attached characteristics list | |
| Endurance | +125 °C 1000 h, rated voltage applied | |
| | Capacitance change | Within ±20 % of the initial value |
| | Dissipation factor (tanδ) | ≤ 200 % of the initial limit |
| | DC leakage current | Within the initial limit |
| Damp heat (Steady state) | +60 °C, 90 % to 95 % RH, 1000 h, No-applied voltage | |
| | Capacitance change | Within ±20 % of the initial value |
| | Dissipation factor (tanδ) | ≤ 150 % of the initial limit |
| | DC leakage current | Within the initial limit (after voltage processing) |

Marking

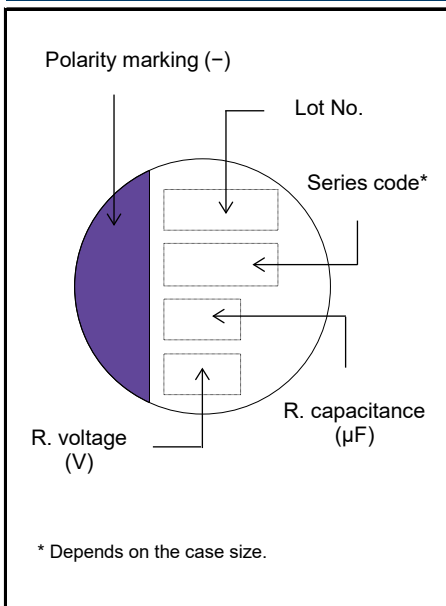

Dimensions (not to scale)

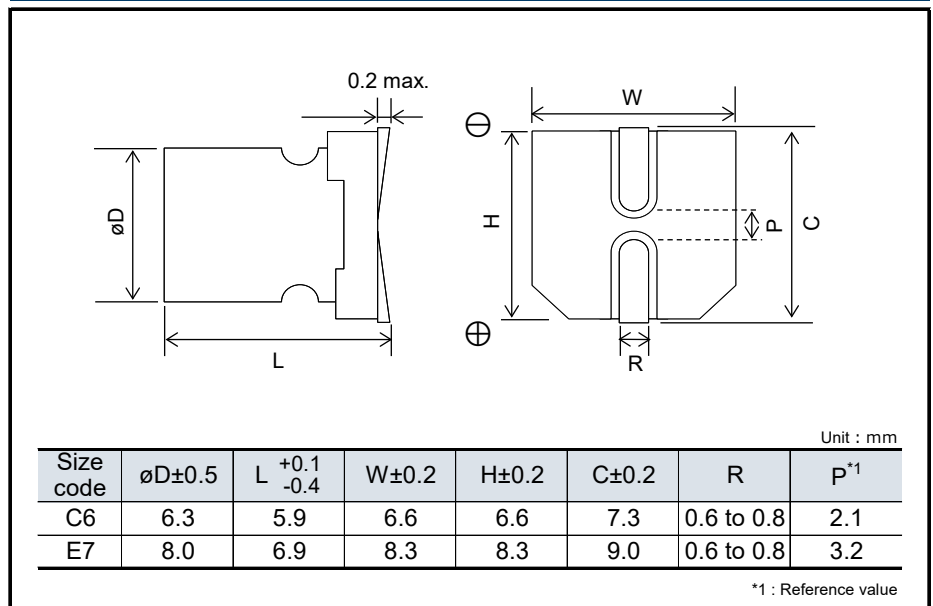

Characteristics list

| Rated voltage (V) | Rated capacitance ($\pm 20\%$) (μF) | Case size (mm) | | Size code | Specifications | | | | | Standard (Reel size : $\phi 380$) | |
|-------------------|--|----------------|-----|-----------|---------------------------------------|---|-------------------------------------|-----------------------------|------------------------------------|------------------------------------|--------------------------|
| | | ϕD | L | | Ripple current ^{*1} (mA rms) | Allowable ripple current ^{*1} (mA rms) | ESR ^{*2} (m Ω max.) | $\tan \delta$ ^{*3} | LC ^{*4} (μA) | Part number | Min. Packaging Qty (pcs) |
| 4.0 | 150 | 6.3 | 5.9 | C6 | 572 | 1810 | 40 | 0.12 | 300 | 4SVQP150M | 1000 |
| | NRFND 82 | 6.3 | 5.9 | | 538 | 1700 | 45 | 0.12 | 258 | 6SVQP82M | 1000 |
| 6.3 | 100 | 6.3 | 5.9 | E7 | 572 | 1810 | 40 | 0.12 | 315 | 6SVQP100M | 1000 |
| | 220 | 8.0 | 6.9 | | 810 | 2560 | 35 | 0.12 | 693 | 6SVQP220M | 1000 |
| 10 | 56 | 6.3 | 5.9 | C6 | 538 | 1700 | 45 | 0.12 | 280 | 10SVQP56M | 1000 |
| | 120 | 8.0 | 6.9 | E7 | 810 | 2560 | 35 | 0.12 | 600 | 10SVQP120M | 1000 |
| | 150 | 8.0 | 6.9 | | 810 | 2560 | 35 | 0.12 | 750 | 10SVQP150M | 1000 |
| 16 | 39 | 6.3 | 5.9 | C6 | 512 | 1620 | 50 | 0.10 | 312 | 16SVQP39M | 1000 |
| | 82 | 8.0 | 6.9 | E7 | 670 | 2120 | 40 | 0.12 | 656 | 16SVQP82M | 1000 |
| 20 | 22 | 6.3 | 5.9 | C6 | 459 | 1450 | 60 | 0.10 | 220 | 20SVQP22M | 1000 |
| | 47 | 8.3 | 6.9 | E7 | 598 | 1890 | 45 | 0.12 | 470 | 20SVQP47M | 1000 |

*1: Ripple current (100 kHz / $+105^\circ\text{C} < \text{Tx} \leq +125^\circ\text{C}$), Allowable ripple current (100 kHz / $\text{Tx} \leq +105^\circ\text{C}$)

NRFND Not recommended for new design

*2: ESR (100 kHz to 300 kHz / $+20^\circ\text{C}$)

*3: $\tan \delta$ (120 Hz / $+20^\circ\text{C}$)

*4: After 2 minutes

◆ Please refer to each page in this catalog for "Reflow conditions" and "Taping specifications".

Frequency correction factor for ripple current

| Frequency(f) | 120 Hz $\leq f < 1$ kHz | 1 kHz $\leq f < 10$ kHz | 10 kHz $\leq f < 100$ kHz | 100 kHz $\leq f < 500$ kHz |
|--------------|-------------------------|-------------------------|---------------------------|----------------------------|
| Coefficient | 0.05 | 0.3 | 0.7 | 1 |

Conductive Polymer Aluminum Solid Capacitors

Surface Mount Type

SVP series



Features

- Standard
- RoHS compliance, Halogen free

Specifications

| Size code | A5 | B6 | C6 | E7 | E12 | F8 | F12 |
|-----------------------------|---|---|-----------|-----------|------------|-----------|-------------|
| Category temp. range | -55 °C to +105 °C | | | | | | |
| Rated voltage range (V) | 4.0 to 16 | 4.0 to 20 | 2.5 to 20 | 4.0 to 20 | 2.5 to 20 | 4.0 to 20 | 2.5 to 20 |
| Nominal cap.range (µF) | 3.3 to 33 | 10 to 68 | 22 to 220 | 33 to 330 | 100 to 680 | 56 to 680 | 150 to 1500 |
| Capacitance tolerance | ±20 % (120 Hz / +20 °C) | | | | | | |
| DC leakage current | Please see the attached characteristics list | | | | | | |
| Dissipation factor (tan δ) | Please see the attached characteristics list | | | | | | |
| Endurance | +105 °C 2000 h, rated voltage applied | | | | | | |
| | Capacitance change | Within ±20 % of the initial value | | | | | |
| | Dissipation factor (tanδ) | ≤ 150 % of the initial limit | | | | | |
| | DC leakage current | Within the initial limit | | | | | |
| Damp heat (Steady state) | +60 °C, 90 % to 95 % RH, 1000 h, No-applied voltage | | | | | | |
| | Capacitance change | Within ±20 % of the initial value | | | | | |
| | Dissipation factor (tanδ) | ≤ 150 % of the initial limit | | | | | |
| | DC leakage current | Within the initial limit (after voltage processing) | | | | | |

Marking

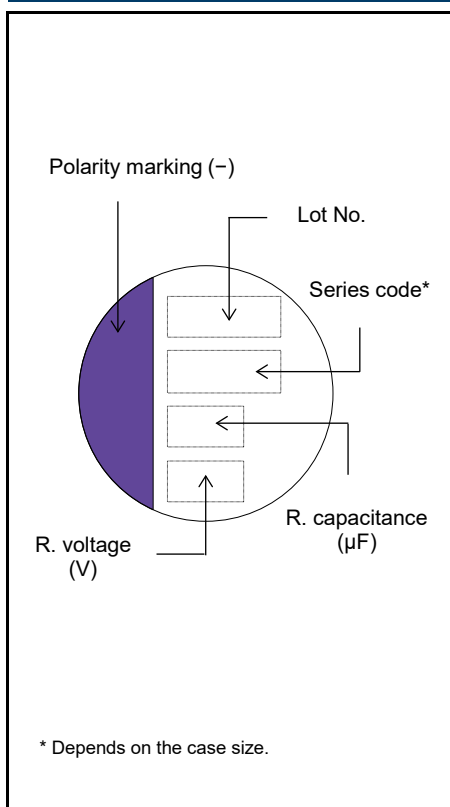

Dimensions (not to scale)

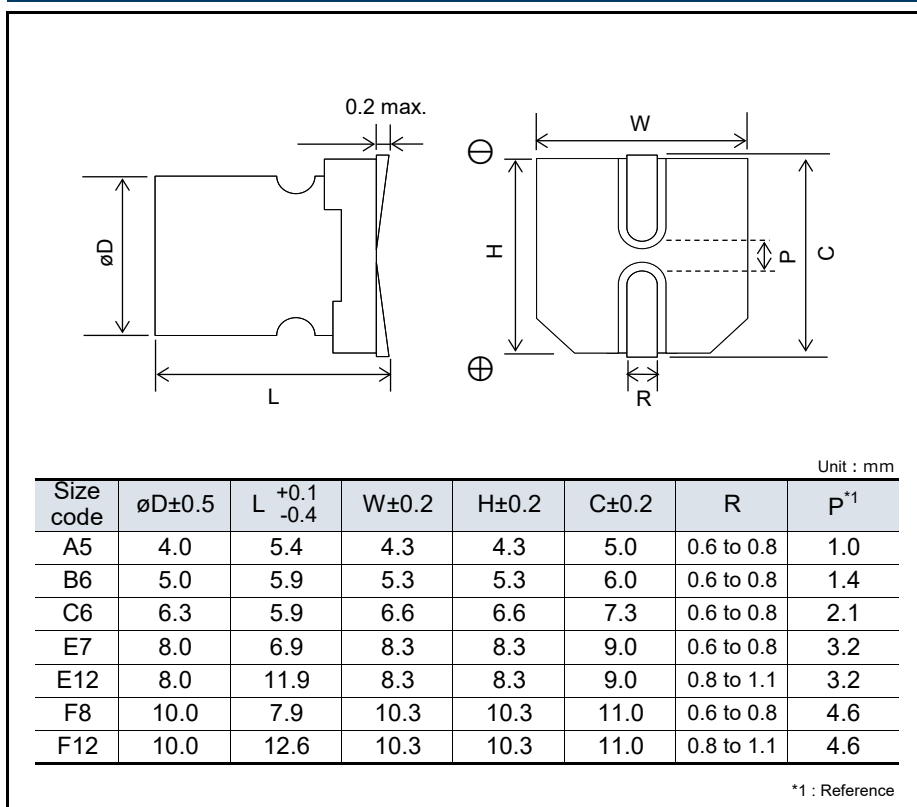

Characteristics list

| Rated voltage (V) | Rated capacitance ($\pm 20\%$) (μF) | Case size (mm) | | Size code | Specifications | | | | Standard (Reel size : $\phi 380$) | |
|-------------------|--|----------------|------|-----------|---------------------------------------|-------------------------------------|-----------------------------|------------------------------------|------------------------------------|--------------------------|
| | | ϕD | L | | Ripple current ^{*1} (mA rms) | ESR ^{*2} (m Ω max.) | $\tan \delta$ ^{*3} | LC ^{*4} (μA) | Part number | Min. Packaging Qty (pcs) |
| 2.5 | 220 | 6.3 | 5.9 | C6 | 2390 | 23 | 0.12 | 110 | 2R5SVP220M | 1000 |
| | 680 | 8.0 | 11.9 | E12 | 4520 | 13 | 0.15 | 340 | 2R5SVP680M | 400 |
| | 1500 | 10.0 | 12.6 | F12 | 5440 | 12 | 0.18 | 750 | 2R5SVP1500M | 400 |
| 4.0 | NRFND 33 | 4.0 | 5.4 | A5 | 740 | 200 | 0.15 | 66 | 4SVP33M | 2000 |
| | NRFND 39 | 5.0 | 5.9 | B6 | 1100 | 70 | 0.12 | 78 | 4SVP39M | 1500 |
| | 68 | 5.0 | 5.9 | | 1400 | 60 | 0.12 | 136 | 4SVP68M | 1500 |
| | 150 | 6.3 | 5.9 | C6 | 1810 | 40 | 0.12 | 120 | 4SVP150MX | 1000 |
| | 330 | 8.0 | 6.9 | E7 | 2560 | 35 | 0.12 | 264 | 4SVP330M | 1000 |
| | 560 | 8.0 | 11.9 | E12 | 4520 | 13 | 0.15 | 448 | 4SVP560M | 400 |
| | 680 | 10.0 | 7.9 | F8 | 3700 | 25 | 0.12 | 544 | 4SVP680M | 500 |
| | 1200 | 10.0 | 12.6 | F12 | 5440 | 12 | 0.18 | 960 | 4SVP1200M | 400 |
| 6.3 | NRFND 22 | 4.0 | 5.4 | A5 | 740 | 200 | 0.12 | 69.3 | 6SVP22M | 2000 |
| | 47 | 5.0 | 5.9 | B6 | 1100 | 70 | 0.12 | 148 | 6SVP47M | 1500 |
| | 82 | 6.3 | 5.9 | C6 | 1700 | 45 | 0.12 | 103 | 6SVP82M | 1000 |
| | 100 | 6.3 | 5.9 | | 1810 | 40 | 0.12 | 126 | 6SVP100M | 1000 |
| | 120 | 6.3 | 5.9 | 2780 | 17 | 0.12 | 151 | 6SVP120MV | 1000 | |
| | 220 | 8.0 | 6.9 | E7 | 2560 | 35 | 0.12 | 277 | 6SVP220MX | 1000 |
| | 330 | 10.0 | 7.9 | F8 | 3700 | 25 | 0.12 | 277 | 6SVP220M | 500 |
| | | 10.0 | 7.9 | | 3700 | 25 | 0.12 | 416 | 6SVP330M | 500 |
| | 470 | 10.0 | 7.9 | E12 | 3700 | 25 | 0.12 | 592 | 6SVP470MX | 500 |
| | | 8.0 | 11.9 | | 4210 | 15 | 0.15 | 592 | 6SVP470M | 400 |
| | 820 | 10.0 | 12.6 | F12 | 5440 | 12 | 0.15 | 775 | 6SVP820M | 400 |
| 10 | NRFND 4.7 | 4.0 | 5.4 | A5 | 670 | 240 | 0.08 | 23.5 | 10SVP4R7M | 2000 |
| | NRFND 6.8 | 4.0 | 5.4 | | 670 | 240 | 0.09 | 34 | 10SVP6R8M | 2000 |
| | NRFND 10 | 4.0 | 5.4 | | 700 | 220 | 0.10 | 50 | 10SVP10M | 2000 |
| | NRFND 15 | 4.0 | 5.4 | | 740 | 200 | 0.10 | 75 | 10SVP15M | 2000 |
| | 33 | 5.0 | 5.9 | B6 | 1100 | 70 | 0.12 | 165 | 10SVP33M | 1500 |
| | 47 | 6.3 | 5.9 | C6 | 1620 | 50 | 0.12 | 94 | 10SVP47M | 1000 |
| | 56 | 6.3 | 5.9 | | 1700 | 45 | 0.12 | 112 | 10SVP56M | 1000 |
| | 120 | 8.0 | 6.9 | E7 | 2560 | 35 | 0.12 | 240 | 10SVP120M | 1000 |
| | 150 | 8.0 | 6.9 | F8 | 2560 | 35 | 0.12 | 300 | 10SVP150MX | 1000 |
| | | 10.0 | 7.9 | | 3020 | 30 | 0.12 | 300 | 10SVP150M | 500 |
| | 270 | 10.0 | 7.9 | 3700 | 25 | 0.12 | 540 | 10SVP270M | 500 | |
| | 330 | 10.0 | 7.9 | E12 | 3700 | 25 | 0.12 | 660 | 10SVP330MX | 500 |
| | | 8.0 | 11.9 | | 3950 | 17 | 0.15 | 660 | 10SVP330M | 400 |
| | 560 | 10.0 | 12.6 | F12 | 5230 | 13 | 0.15 | 840 | 10SVP560M | 400 |
| 16 | NRFND 3.3 | 4.0 | 5.4 | A5 | 660 | 260 | 0.07 | 26.4 | 16SVP3R3M | 2000 |
| | 15 | 5.0 | 5.9 | B6 | 1020 | 120 | 0.10 | 120 | 16SVP15M | 1500 |
| | 22 | 5.0 | 5.9 | | 1060 | 90 | 0.10 | 176 | 16SVP22M | 1500 |
| | 39 | 6.3 | 5.9 | C6 | 1620 | 50 | 0.10 | 125 | 16SVP39M | 1000 |
| | 56 | 8.0 | 6.9 | E7 | 1890 | 45 | 0.12 | 179 | 16SVP56M | 1000 |
| | 82 | 8.0 | 6.9 | | 2120 | 40 | 0.12 | 262 | 16SVP82M | 1000 |
| | 100 | 10.0 | 7.9 | F8 | 2670 | 35 | 0.12 | 320 | 16SVP100M | 500 |
| | 150 | 10.0 | 7.9 | | 3020 | 30 | 0.12 | 480 | 16SVP150M | 500 |
| | 180 | 10.0 | 7.9 | | 3020 | 30 | 0.12 | 576 | 16SVP180MX | 500 |
| | | 8.0 | 11.9 | | E12 | 3640 | 20 | 0.15 | 576 | 16SVP180M |
| | 330 | 10.0 | 12.6 | F12 | 4720 | 16 | 0.15 | 792 | 16SVP330M | 400 |
| 20 | 10 | 5.0 | 5.9 | B6 | 1020 | 120 | 0.10 | 100 | 20SVP10M | 1500 |
| | 22 | 6.3 | 5.9 | C6 | 1450 | 60 | 0.10 | 88 | 20SVP22M | 1000 |
| | 27 | 6.3 | 5.9 | | 1450 | 60 | 0.10 | 108 | 20SVP27M | 1000 |
| | 33 | 8.0 | 6.9 | E7 | 1890 | 45 | 0.12 | 132 | 20SVP33M | 1000 |
| | 47 | 8.0 | 6.9 | F8 | 1890 | 45 | 0.12 | 188 | 20SVP47M | 1000 |
| | 56 | 10.0 | 7.9 | | 2400 | 40 | 0.12 | 224 | 20SVP56M | 500 |
| | 68 | 10.0 | 7.9 | 2400 | 40 | 0.12 | 272 | 20SVP68M | 500 | |
| | 100 | 8.0 | 11.9 | E12 | 3320 | 24 | 0.15 | 400 | 20SVP100M | 400 |
| | 150 | 10.0 | 12.6 | F12 | 4320 | 20 | 0.15 | 600 | 20SVP150M | 400 |

*1: Ripple current (100 kHz / +105 °C)

*2: ESR (100 kHz to 300 kHz/+20 °C)

*3: $\tan \delta$ (120 Hz / +20 °C)

*4: After 2 minutes

NRFND Not recommended for new design

◆ Please refer to each page in this catalog for "Reflow conditions" and "Taping specifications".

Frequency correction factor for ripple current

| Frequency(f) | 120 Hz $\leq f < 1$ kHz | 1 kHz $\leq f < 10$ kHz | 10 kHz $\leq f < 100$ kHz | 100 kHz $\leq f < 500$ kHz |
|--------------|-------------------------|-------------------------|---------------------------|----------------------------|
| Coefficient | 0.05 | 0.3 | 0.7 | 1 |

Conductive Polymer Aluminum Solid Capacitors Radial Lead Type SEF series



Features

- High voltage (35 V max.)
- Large capacitance (1000 μ F max.)
- RoHS compliance, Halogen free

Specifications

| Size code | C6 | E7 | E12 | F13 |
|------------------------------------|---|---|---------------------------|-----------------------------|
| Category temp. range | -55 °C to +125 °C | | | |
| Rated voltage range | 16 V to 35 V | | | |
| Nominal cap.range | 22 μ F to 180 μ F | 39 μ F to 270 μ F | 82 μ F to 560 μ F | 120 μ F to 1000 μ F |
| Capacitance tolerance | \pm 20 % (120 Hz / +20 °C) | | | |
| DC leakage current | Please see the attached characteristics list | | | |
| Dissipation factor (tan δ) | Please see the attached characteristics list | | | |
| Endurance | +125 °C 1000 h, rated voltage applied | | | |
| | Capacitance change | Within \pm 20 % of the initial value | | |
| | Dissipation factor (tan δ) | \leq 200 % of the initial limit | | |
| | DC leakage current | Within the initial limit | | |
| Damp heat (Steady state) | +60 °C, 90 % to 95 % RH, 1000 h, No-applied voltage | | | |
| | Capacitance change | Within \pm 20 % of the initial value | | |
| | Dissipation factor (tan δ) | \leq 150 % of the initial limit | | |
| | DC leakage current | Within the initial limit (after voltage processing) | | |

Marking

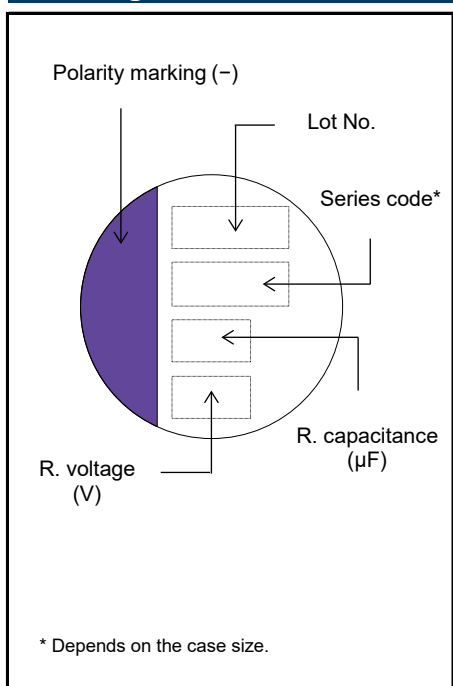

Dimensions (not to scale)

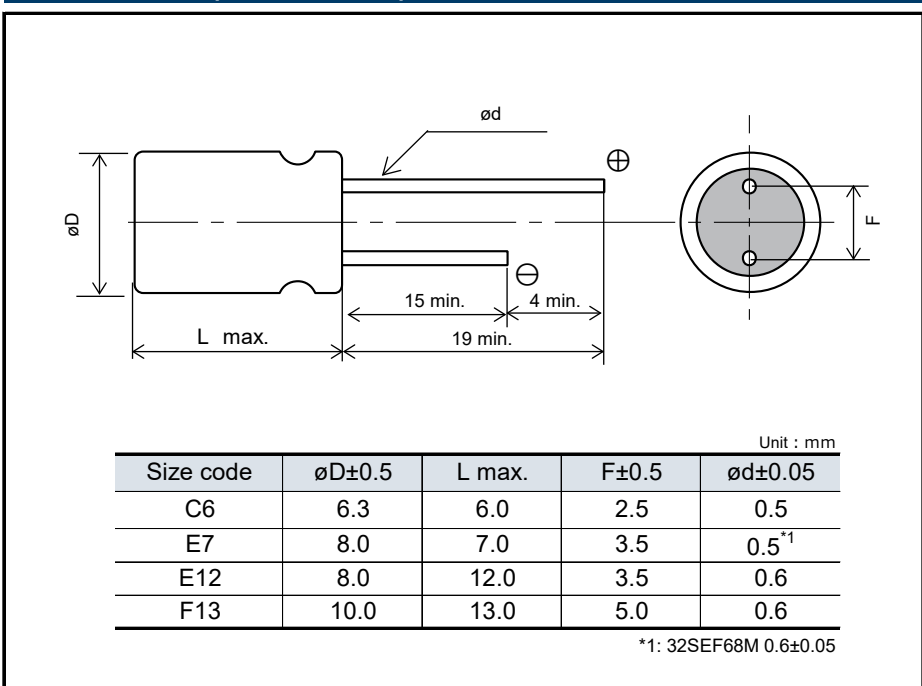

Characteristics list

| Rated voltage (V) | Rated capacitance ($\pm 20\%$) (μF) | Case size (mm) | | Size code | Specifications | | | | | Part number <small>Click here for part number list of lead terminal cutting and lead terminal taping</small> |
|-------------------|--|-----------------------|------|-----------|---------------------------------------|---|-------------------------------------|-----------------------------|------------------------------------|---|
| | | $\varnothing\text{D}$ | L | | Ripple current ^{*1} (mA rms) | Allowable ripple current ^{*1} (mA rms) | ESR ^{*2} (m Ω max.) | $\tan \delta$ ^{*3} | LC ^{*4} (μA) | |
| 16 | 180 | 6.3 | 6.0 | C6 | 1040 | 3300 | 22 | 0.12 | 576 | 16SEF180M |
| | 270 | 8.0 | 7.0 | E7 | 1040 | 3300 | 22 | 0.12 | 864 | 16SEF270M |
| | 560 | 8.0 | 12.0 | E12 | 1560 | 4950 | 14 | 0.12 | 1792 | 16SEF560M |
| | 1000 | 10.0 | 13.0 | F13 | 1700 | 5400 | 12 | 0.12 | 3200 | 16SEF1000M |
| 20 | 120 | 6.3 | 6.0 | C6 | 1010 | 3200 | 25 | 0.12 | 480 | 20SEF120M |
| | 180 | 8.0 | 7.0 | E7 | 1010 | 3200 | 25 | 0.12 | 720 | 20SEF180M |
| | 390 | 8.0 | 12.0 | E12 | 1560 | 4950 | 14 | 0.12 | 1560 | 20SEF390M |
| | 560 | 10.0 | 13.0 | F13 | 1700 | 5400 | 12 | 0.12 | 2240 | 20SEF560M |
| 25 | 56 | 6.3 | 6.0 | C6 | 880 | 2800 | 30 | 0.12 | 280 | 25SEF56M |
| | 82 | 8.0 | 7.0 | E7 | 940 | 3000 | 28 | 0.12 | 410 | 25SEF82M |
| | 180 | 8.0 | 12.0 | E12 | 1470 | 4650 | 16 | 0.12 | 900 | 25SEF180M |
| | 330 | 10.0 | 13.0 | F13 | 1580 | 5000 | 14 | 0.12 | 1650 | 25SEF330M |
| 32 | 68 | 8.0 | 7.0 | E7 | 1010 | 3200 | 25 | 0.10 | 435 | 32SEF68M |
| 35 | 22 | 6.3 | 6.0 | C6 | 820 | 2600 | 35 | 0.12 | 154 | 35SEF22M |
| | 39 | 8.0 | 7.0 | E7 | 880 | 2800 | 30 | 0.12 | 273 | 35SEF39M |
| | 82 | 8.0 | 12.0 | E12 | 1260 | 4000 | 20 | 0.12 | 574 | 35SEF82M |
| | 120 | 10.0 | 13.0 | F13 | 1390 | 4400 | 18 | 0.12 | 840 | 35SEF120M |

*1: Ripple current (100 kHz / +105 °C < Tx ≤ +125 °C) / Allowable ripple current (100 kHz / Tx ≤ +105 °C)

*2: ESR (100 kHz to 300 kHz / +20 °C)

*3: $\tan \delta$ (120 Hz / +20 °C)

*4: After 2 minutes

◆ Please refer to each page in this catalog for "Flow conditions" and "Taping specifications".

Frequency correction factor for ripple current

| Frequency(f) | 120 Hz ≤ f < 1 kHz | 1 kHz ≤ f < 10 kHz | 10 kHz ≤ f < 100 kHz | 100 kHz ≤ f < 500 kHz |
|--------------|--------------------|--------------------|----------------------|-----------------------|
| Coefficient | 0.05 | 0.3 | 0.7 | 1 |



**Conductive Polymer Aluminum
Solid Capacitors
Radial Lead Type
SEK series**

Features

- High voltage (50 V max.)
- 125 °C 1000 h
- RoHS compliance, Halogen free

Specifications

| Size code | C6 | E7 | E12 | F13 |
|-----------------------------|---|---|-----------------|------------------|
| Category temp. range | -55 °C to +125 °C | | | |
| Rated voltage range | 25 V to 50 V | | | |
| Nominal cap.range | 22 µF to 82 µF | 33 µF to 120 µF | 68 µF to 270 µF | 120 µF to 470 µF |
| Capacitance tolerance | ±20 % (120 Hz / +20 °C) | | | |
| DC leakage current | Please see the attached characteristics list | | | |
| Dissipation factor (tan δ) | Please see the attached characteristics list | | | |
| Endurance | +125 °C 1000 h, rated voltage applied | | | |
| | Capacitance change | Within ±20 % of the initial value | | |
| | Dissipation factor (tanδ) | ≤ 200 % of the initial limit | | |
| | DC leakage current | Within the initial limit | | |
| Damp heat (Steady state) | +60 °C, 90 % to 95 % RH, 1000 h, No-applied voltage | | | |
| | Capacitance change | Within ±20 % of the initial value | | |
| | Dissipation factor (tanδ) | ≤ 150 % of the initial limit | | |
| | DC leakage current | Within the initial limit (after voltage processing) | | |

Marking

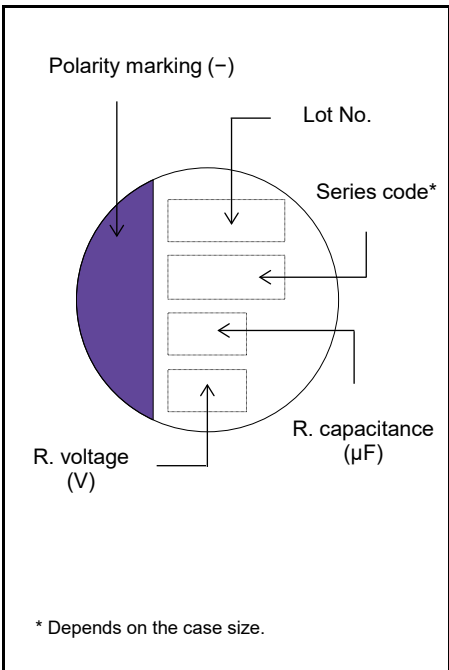

Dimensions (not to scale)

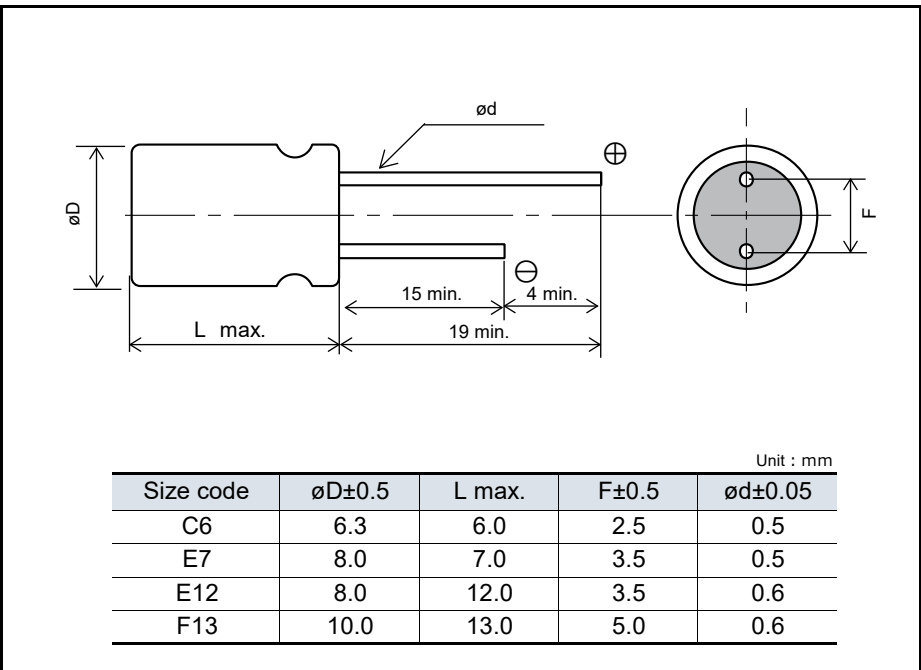

Characteristics list

| Rated voltage (V) | Rated capacitance ($\pm 20\%$) (μF) | Case size (mm) | | Size code | Specifications | | | | | Part number Click here for part number list of lead terminal cutting and lead terminal taping |
|-------------------|--|-----------------------|------|-----------|---------------------------------------|---|-------------------------------------|-----------------------------|------------------------------------|--|
| | | $\varnothing\text{D}$ | L | | Ripple current ^{*1} (mA rms) | Allowable ripple current ^{*1} (mA rms) | ESR ^{*2} (m Ω max.) | $\tan \delta$ ^{*3} | LC ^{*4} (μA) | |
| 25 | 82 | 6.3 | 6.0 | C6 | 960 | 3060 | 25 | 0.12 | 410 | 25SEK82M |
| | 120 | 8.0 | 7.0 | E7 | 1010 | 3200 | 24 | 0.12 | 600 | 25SEK120M |
| | 270 | 8.0 | 12.0 | E12 | 1470 | 4650 | 16 | 0.12 | 1350 | 25SEK270M |
| | 470 | 10.0 | 13.0 | F13 | 1590 | 5000 | 14 | 0.12 | 2350 | 25SEK470M |
| 35 | 47 | 6.3 | 6.0 | C6 | 930 | 2950 | 27 | 0.12 | 329 | 35SEK47M |
| | 82 | 8.0 | 7.0 | E7 | 960 | 3060 | 25 | 0.12 | 574 | 35SEK82M |
| | 180 | 8.0 | 12.0 | E12 | 1260 | 4000 | 20 | 0.12 | 1260 | 35SEK180M |
| | 330 | 10.0 | 13.0 | F13 | 1390 | 4400 | 18 | 0.12 | 2310 | 35SEK330M |
| 50 | 22 | 6.3 | 6.0 | C6 | 820 | 2600 | 35 | 0.12 | 220 | 50SEK22M |
| | 33 | 8.0 | 7.0 | E7 | 850 | 2700 | 35 | 0.12 | 330 | 50SEK33M |
| | 68 | 8.0 | 12.0 | E12 | 1200 | 3800 | 25 | 0.12 | 680 | 50SEK68M |
| | 120 | 10.0 | 13.0 | F13 | 1350 | 4300 | 20 | 0.12 | 1200 | 50SEK120M |

*1: Ripple current (100 kHz / +105 °C < Tx \leq +125 °C) / Allowable ripple current (100 kHz / Tx \leq +105 °C)

*2: ESR (100 kHz to 300 kHz / +20 °C)

*3: $\tan \delta$ (120 Hz / +20 °C)

*4: After 2 minutes

◆ Please refer to each page in this catalog for "Flow conditions" and "Taping specifications".

Frequency correction factor for ripple current

| Frequency(f) | 120 Hz \leq f < 1 kHz | 1 kHz \leq f < 10 kHz | 10 kHz \leq f < 100 kHz | 100 kHz \leq f < 500 kHz |
|--------------|-------------------------|-------------------------|---------------------------|----------------------------|
| Coefficient | 0.05 | 0.3 | 0.7 | 1 |

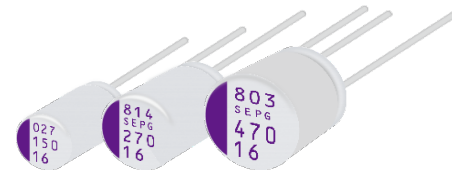

Conductive Polymer Aluminum Solid Capacitors Radial Lead Type SEPG series

Features

- High ripple current (6100 mA rms max.)
- RoHS compliance, Halogen free

Specifications

| Size code | B9 | C9 | C10 | E9 | E13 |
|-----------------------------|---|---|-----|--------|--------|
| Category temp. range | -55 °C to +105 °C | | | | |
| Rated voltage range | 16 V | | | | |
| Rated cap. range | 150 μF | 270 μF | | 470 μF | 560 μF |
| Capacitance tolerance | ±20 % (120 Hz / +20 °C) | | | | |
| Leakage current | Please see the attached characteristics list | | | | |
| Dissipation factor (tan δ) | Please see the attached characteristics list | | | | |
| Endurance | +105 °C 5000 h, rated voltage applied | | | | |
| | Capacitance change | Within ±20 % of the initial value | | | |
| | Dissipation factor (tan δ) | ≤ 200 % of the initial limit | | | |
| | DC leakage current | Within the initial limit | | | |
| Damp heat (Steady State) | +60 °C, 90 % to 95 % RH, 1000 h, No-applied voltage | | | | |
| | Capacitance change | Within ±20 % of the initial value | | | |
| | Dissipation factor (tan δ) | ≤ 150 % of the initial limit | | | |
| | DC leakage current | Within the initial limit (after voltage processing) | | | |

Marking

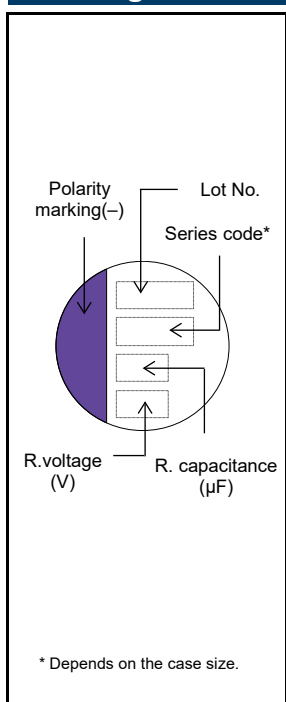

Dimensions (not to scale)

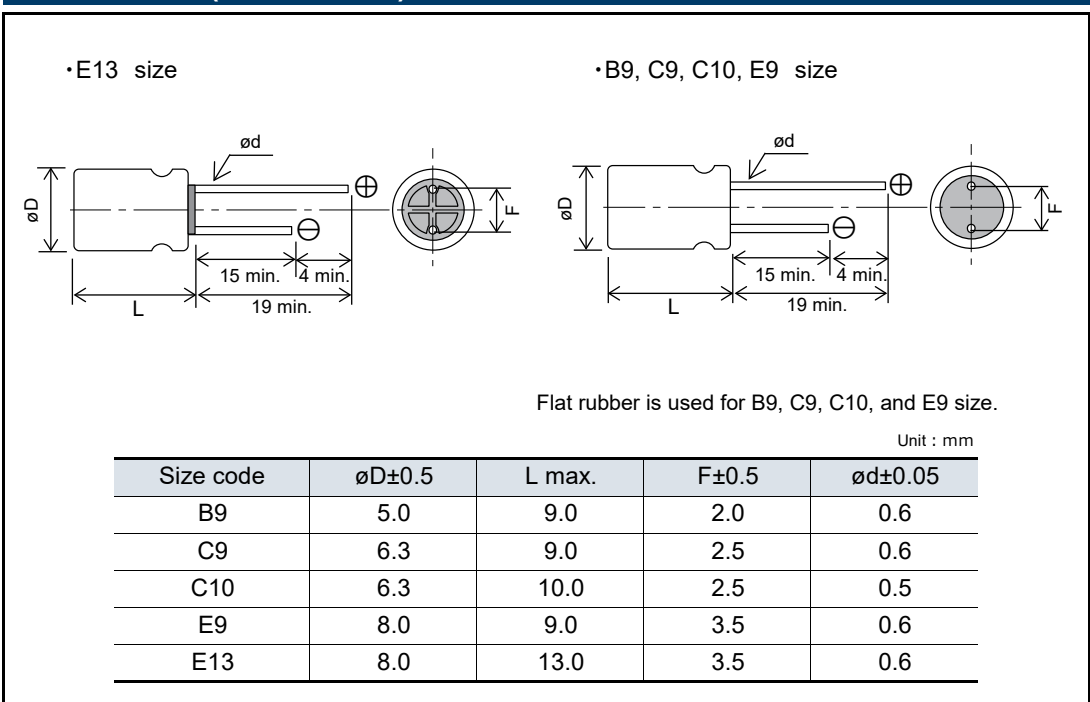

Characteristics list

| Rated voltage (V) | Rated capacitance ($\pm 20\%$) (μF) | Case size (mm) | | Size code | Specifications | | | | Part number <small>Click here for part number list of lead terminal cutting and lead terminal taping</small> |
|-------------------|--|-----------------------|------|-----------|---------------------------------------|-------------------------------------|-----------------------------|------------------------------------|---|
| | | $\varnothing\text{D}$ | L | | Ripple current ^{*1} (mA rms) | ESR ^{*2} (m Ω max.) | $\tan \delta$ ^{*3} | LC ^{*4} (μA) | |
| 16 | 150 | 5.0 | 9.0 | B9 | 4500 | 12 | 0.12 | 480 | 16SEPG150M |
| | 270 | 6.3 | 9.0 | C9 | 5040 | 10 | 0.12 | 864 | 16SEPG270W |
| | | 6.3 | 10.0 | C10 | 5800 | 8 | 0.12 | 864 | 16SEPG270M |
| | 470 | 8.0 | 9.0 | E9 | 5400 | 8 | 0.12 | 1504 | 16SEPG470M |
| | 560 | 8.0 | 13.0 | E13 | 6100 | 8 | 0.12 | 1792 | 16SEPG560M |

*1: Ripple current (100 kHz / +105 °C)

*2: ESR (100 kHz / +20 °C)

*3: $\tan \delta$ (120 Hz / +20 °C)

*4: After 2 minutes

◆ Please refer to each page in this catalog for "Flow conditions" and "Taping specifications".

Frequency correction factor for ripple current

| Frequency(f) | 120 Hz \leq f < 1 kHz | 1 kHz \leq f < 10 kHz | 10 kHz \leq f < 100 kHz | 100 kHz \leq f < 500 kHz |
|--------------|-------------------------|-------------------------|---------------------------|----------------------------|
| Coefficient | 0.05 | 0.3 | 0.7 | 1 |

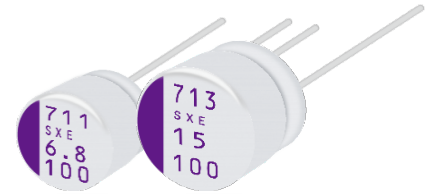

Conductive Polymer Aluminum Solid Capacitors Radial Lead Type SXE series

Features

- Super high voltage (100 V max.)
- 125 °C 1000 h
- RoHS compliance, Halogen free

Specifications

| Size code | E7 | E12 | F8 | F13 |
|-----------------------------|---|---|----------------|-----------------|
| Category temp. range | -55 °C to +125 °C | | | |
| Rated voltage range | 63 V to 100 V | | | |
| Nominal cap.range | 6.8 μF to 18 μF | 15 μF to 68 μF | 15 μF to 39 μF | 18 μF to 120 μF |
| Capacitance tolerance | ±20 % (120 Hz / +20 °C) | | | |
| DC leakage current | Please see the attached characteristics list | | | |
| Dissipation factor (tan δ) | Please see the attached characteristics list | | | |
| Endurance | +125 °C 1000 h, rated voltage applied | | | |
| | Capacitance change | Within ±20 % of the initial value | | |
| | Dissipation factor (tanδ) | ≤ 200 % of the initial limit | | |
| | DC leakage current | Within the initial limit | | |
| Damp heat (Steady state) | +60 °C, 90 % to 95 % RH, 1000 h, No-applied voltage | | | |
| | Capacitance change | Within ±20 % of the initial value | | |
| | Dissipation factor (tanδ) | ≤ 150 % of the initial limit | | |
| | DC leakage current | Within the initial limit (after voltage processing) | | |

Marking

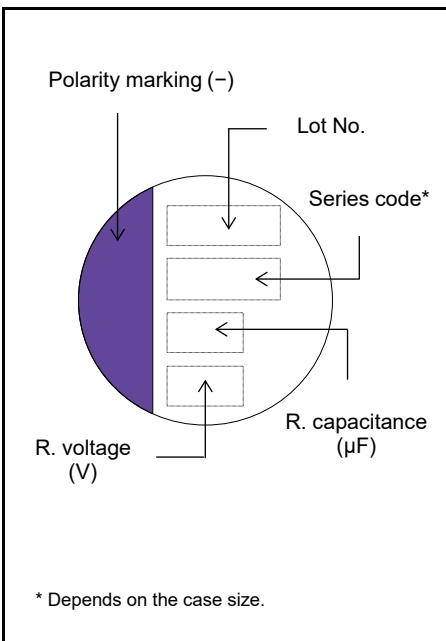

Dimensions (not to scale)

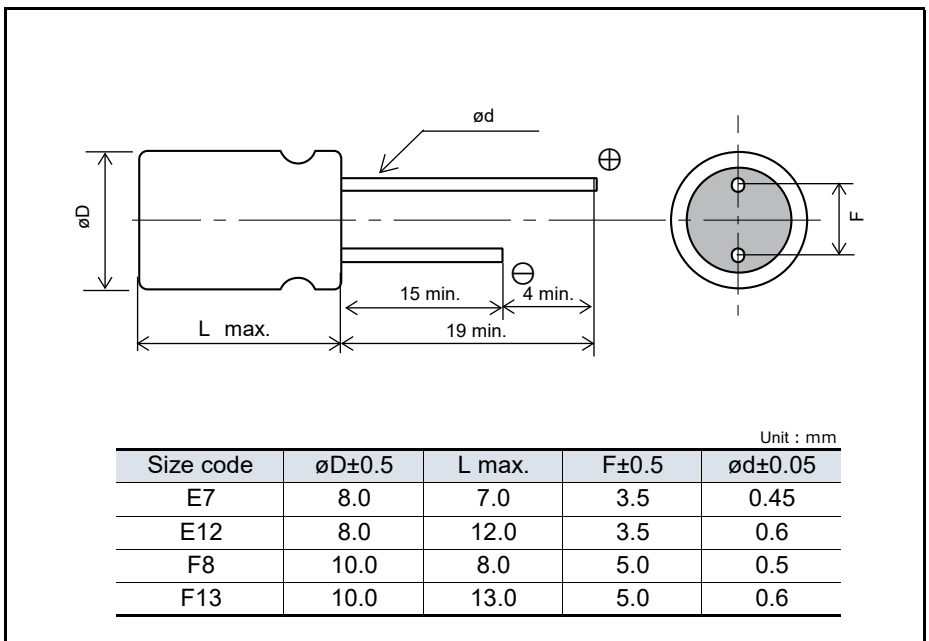

Characteristics list

| Rated voltage (V) | Rated capacitance (±20 %) (μF) | Case size (mm) | | Size code | Specifications | | | | | Part number Click here for part number list of lead terminal cutting and lead terminal taping |
|-------------------|--------------------------------|----------------|------|-----------|---------------------------------------|---|-----------------------------|---------------------|-----------------------|--|
| | | øD | L | | Ripple current* ¹ (mA rms) | Allowable ripple current* ¹ (mA rms) | ESR* ² (mΩ max.) | tan δ* ³ | LC* ⁴ (μA) | |
| 63 | 18 | 8.0 | 7.0 | E7 | 340 | 1100 | 60 | 0.12 | 56 | 63SXE18M |
| | 33 | 8.0 | 12.0 | E12 | 930 | 2950 | 25 | 0.12 | 104 | 63SXE33M |
| | 39 | 8.0 | 12.0 | E12 | 930 | 2950 | 25 | 0.12 | 122 | 63SXE39M |
| | | 10.0 | 8.0 | F8 | 690 | 2190 | 50 | 0.12 | 122 | 63SXE39MX |
| | 56 | 8.0 | 12.0 | E12 | 930 | 2950 | 25 | 0.12 | 176 | 63SXE56M |
| | 68 | 8.0 | 12.0 | E12 | 930 | 2950 | 25 | 0.12 | 214 | 63SXE68MX |
| | | 10.0 | 13.0 | F13 | 1030 | 3280 | 25 | 0.12 | 214 | 63SXE68M |
| | 100 | 10.0 | 13.0 | F13 | 1030 | 3280 | 25 | 0.12 | 315 | 63SXE100M |
| 120 | 10.0 | 13.0 | F13 | 1030 | 3280 | 25 | 0.12 | 378 | 63SXE120M | |
| 72 | 82 | 10.0 | 13.0 | F13 | 980 | 3100 | 28 | 0.12 | 295 | 72SXE82M |
| | 100 | 10.0 | 13.0 | F13 | 980 | 3100 | 28 | 0.12 | 360 | 72SXE100M |
| 80 | 12 | 8.0 | 7.0 | E7 | 340 | 1100 | 60 | 0.12 | 48 | 80SXE12M |
| | 27 | 8.0 | 12.0 | E12 | 780 | 2490 | 35 | 0.12 | 108 | 80SXE27M |
| | | 10.0 | 8.0 | F8 | 660 | 2080 | 55 | 0.12 | 108 | 80SXE27MX |
| | 33 | 8.0 | 12.0 | E12 | 780 | 2490 | 35 | 0.12 | 132 | 80SXE33M |
| | 47 | 8.0 | 12.0 | E12 | 780 | 2490 | 35 | 0.12 | 188 | 80SXE47MX |
| | | 10.0 | 13.0 | F13 | 980 | 3100 | 28 | 0.12 | 188 | 80SXE47M |
| | 56 | 10.0 | 13.0 | F13 | 980 | 3100 | 28 | 0.12 | 224 | 80SXE56M |
| 82 | 10.0 | 13.0 | F13 | 980 | 3100 | 28 | 0.12 | 328 | 80SXE82M | |
| 100 | 6.8 | 8.0 | 7.0 | E7 | 340 | 1100 | 60 | 0.12 | 34 | 100SXE6R8M |
| | 15 | 10.0 | 8.0 | F8 | 630 | 2000 | 60 | 0.12 | 75 | 100SXE15MX |
| | | 8.0 | 12.0 | E12 | 730 | 2350 | 40 | 0.12 | 75 | 100SXE15M |
| | 18 | 10.0 | 13.0 | F13 | 940 | 3000 | 30 | 0.12 | 90 | 100SXE18M |
| | | 8.0 | 12.0 | E12 | 730 | 2350 | 40 | 0.12 | 90 | 100SXE18MX |
| | 22 | 10.0 | 13.0 | F13 | 940 | 3000 | 30 | 0.12 | 110 | 100SXE22M |
| | 27 | 8.0 | 12.0 | E12 | 730 | 2350 | 40 | 0.12 | 135 | 100SXE27MX |
| | | 10.0 | 13.0 | F13 | 940 | 3000 | 30 | 0.12 | 135 | 100SXE27M |
| | 39 | 10.0 | 13.0 | F13 | 940 | 3000 | 30 | 0.12 | 195 | 100SXE39M |

*1: Ripple current (100 kHz / +105 °C < Tx ≤ +125 °C) / Allowable ripple current (100 kHz / Tx ≤ +105 °C)

*2: ESR (100 kHz to 300 kHz / +20 °C)

*3: tan δ (120 Hz / +20 °C)

*4: After 2 minutes

◆ Please refer to each page in this catalog for "Flow conditions" and "Taping specifications".

Frequency correction factor for ripple current

| Frequency(f) | 120 Hz ≤ f < 1 kHz | 1 kHz ≤ f < 10 kHz | 10 kHz ≤ f < 100 kHz | 100 kHz ≤ f < 500 kHz |
|--------------|--------------------|--------------------|----------------------|-----------------------|
| Coefficient | 0.05 | 0.3 | 0.7 | 1 |

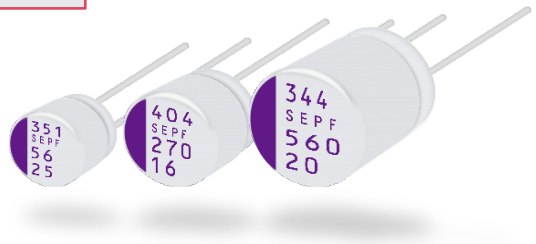

**Conductive Polymer Aluminum
Solid Capacitors**
Radial Lead Type
SEPF series

Features

- High voltage (35 V max.)
- Large capacitance (1000 μF max.)
- RoHS compliance, Halogen free

Specifications

| Size code | C55 | C6 | E7 | E12 | F13 |
|----------------------------|---|---|-----------------|-----------------|-------------------|
| Category temp. range | -55 °C to +105 °C | | | | |
| Rated voltage range | 16 V to 32 V | 16 V to 35 V | | | |
| Nominal cap.range | 22 μF to 150 μF | 22 μF to 180 μF | 39 μF to 270 μF | 82 μF to 560 μF | 120 μF to 1000 μF |
| Capacitance tolerance | ±20 % (120 Hz / +20 °C) | | | | |
| DC leakage current | Please see the attached characteristics list | | | | |
| Dissipation factor (tan δ) | Please see the attached characteristics list | | | | |
| Endurance | +105 °C 5000 h, rated voltage applied | | | | |
| | Capacitance change | Within ±20 % of the initial value | | | |
| | Dissipation factor (tanδ) | ≤ 150 % of the initial limit | | | |
| | DC leakage current | Within the initial limit | | | |
| Damp heat (Steady state) | +60 °C, 90 % to 95 % RH, 1000 h, No-applied voltage | | | | |
| | Capacitance change | Within ±20 % of the initial value | | | |
| | Dissipation factor (tanδ) | ≤ 150 % of the initial limit | | | |
| | DC leakage current | Within the initial limit (after voltage processing) | | | |

Marking

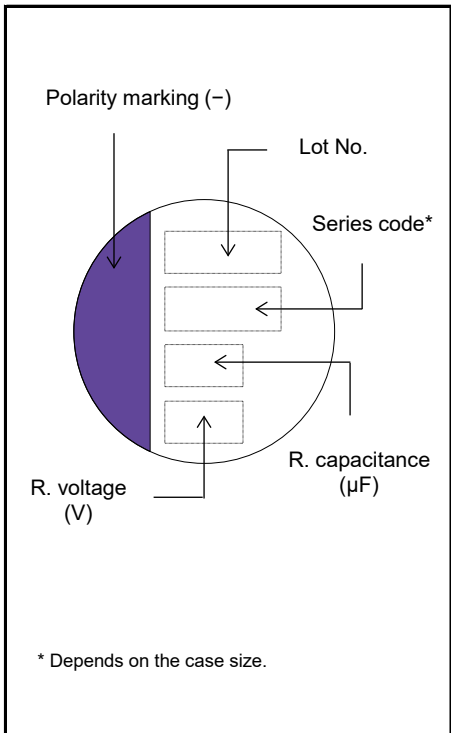

Dimensions (not to scale)

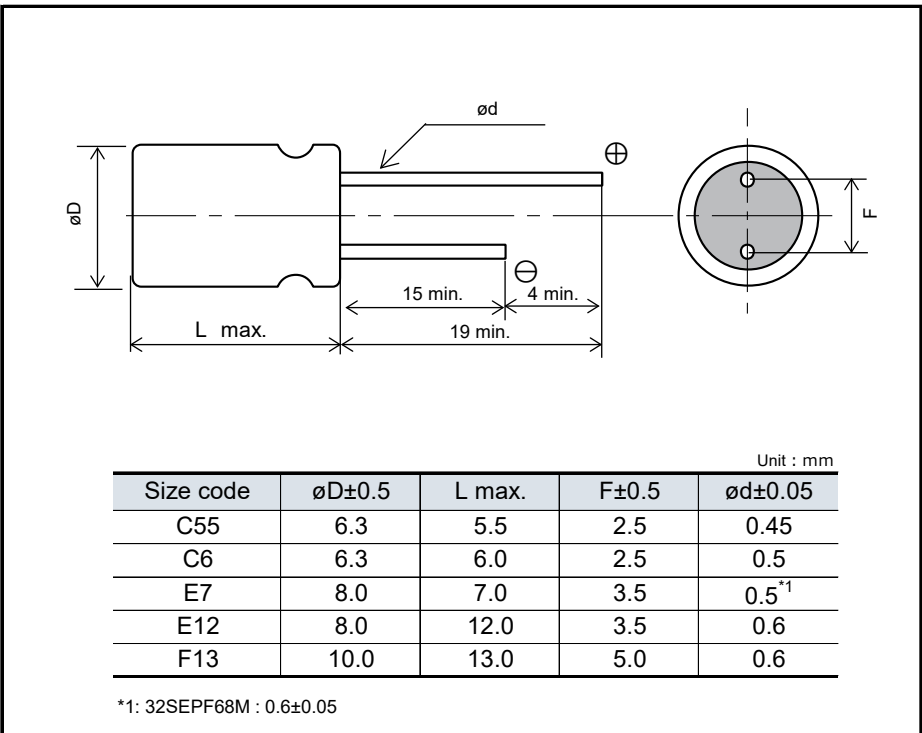

Characteristics list

| Rated voltage (V) | Rated capacitance ($\pm 20\%$) (μF) | Case size (mm) | | Size code | Specifications | | | | Part number <small>Click here for part number list of lead terminal cutting and lead terminal taping</small> |
|-------------------|--|-----------------------|------|-----------|---------------------------------------|-------------------------------------|-----------------------------|------------------------------------|---|
| | | $\varnothing\text{D}$ | L | | Ripple current ^{*1} (mA rms) | ESR ^{*2} (m Ω max.) | $\tan \delta$ ^{*3} | LC ^{*4} (μA) | |
| 16 | 150 | 6.3 | 5.5 | C55 | 2590 | 30 | 0.12 | 480 | 16SEPF150M |
| | 180 | 6.3 | 6.0 | C6 | 3300 | 22 | 0.12 | 576 | 16SEPF180M |
| | 270 | 8.0 | 7.0 | E7 | 3300 | 22 | 0.12 | 864 | 16SEPF270M |
| | 560 | 8.0 | 12.0 | E12 | 4950 | 14 | 0.12 | 1792 | 16SEPF560M |
| | 1000 | 10.0 | 13.0 | F13 | 5400 | 12 | 0.12 | 3200 | 16SEPF1000M |
| 20 | 120 | 6.3 | 6.0 | C6 | 3200 | 25 | 0.12 | 480 | 20SEPF120M |
| | 180 | 8.0 | 7.0 | E7 | 3200 | 25 | 0.12 | 720 | 20SEPF180M |
| | 390 | 8.0 | 12.0 | E12 | 4950 | 14 | 0.12 | 1560 | 20SEPF390M |
| | 560 | 10.0 | 13.0 | F13 | 5400 | 12 | 0.12 | 2240 | 20SEPF560M |
| 25 | 56 | 6.3 | 6.0 | C6 | 2800 | 30 | 0.12 | 280 | 25SEPF56M |
| | 82 | 8.0 | 7.0 | E7 | 3000 | 28 | 0.12 | 410 | 25SEPF82M |
| | 180 | 8.0 | 12.0 | E12 | 4650 | 16 | 0.12 | 900 | 25SEPF180M |
| | 330 | 10.0 | 13.0 | F13 | 5000 | 14 | 0.12 | 1650 | 25SEPF330M |
| 32 | 22 | 6.3 | 5.5 | C55 | 2400 | 35 | 0.12 | 140 | 32SEPF22M |
| | 68 | 8.0 | 7.0 | E7 | 3200 | 25 | 0.10 | 435 | 32SEPF68M |
| 35 | 22 | 6.3 | 6.0 | C6 | 2600 | 35 | 0.12 | 154 | 35SEPF22M |
| | 39 | 8.0 | 7.0 | E7 | 2800 | 30 | 0.12 | 273 | 35SEPF39M |
| | 82 | 8.0 | 12.0 | E12 | 4000 | 20 | 0.12 | 574 | 35SEPF82M |
| | 120 | 10.0 | 13.0 | F13 | 4400 | 18 | 0.12 | 840 | 35SEPF120M |

*1: Ripple current (100 kHz / +105 °C)

*2: ESR (100 kHz to 300 kHz / +20 °C)

*3: $\tan \delta$ (120 Hz / +20 °C)

*4: After 2 minutes

◆ Please refer to each page in this catalog for "Flow conditions" and "Taping specifications".

Frequency correction factor for ripple current

| Frequency(f) | 120 Hz \leq f < 1 kHz | 1 kHz \leq f < 10 kHz | 10 kHz \leq f < 100 kHz | 100 kHz \leq f < 500 kHz |
|--------------|-------------------------|-------------------------|---------------------------|----------------------------|
| Coefficient | 0.05 | 0.3 | 0.7 | 1 |

Conductive Polymer Aluminum Solid Capacitors

Radial Lead Type

SEPC series



Features

- Super low ESR (5 mΩ max.)
- Large capacitance (2700 μF max.)
- RoHS compliance, Halogen free

Specifications

| Size code | B9 | C55 | C6 | C9 | E7 | E9 | E12 | E13 | F13 |
|-----------------------------|---|---|------------|------------|-------------|-------------|------------|------------|-------------|
| Category temp. range | -55 °C to +105 °C | | | | | | | | |
| Rated voltage range (V) | 2.5 | 6.3 | 2.5 to 16 | | 6.3 to 16 | 2.5 to 16 | 16 | 2.5 to 6.3 | 2.5 to 16 |
| Nominal cap.range (μF) | 100 to 560 | 220 | 100 to 560 | 100 to 820 | 150 to 1000 | 180 to 1000 | 180 to 270 | 470 to 820 | 470 to 2700 |
| Capacitance tolerance | ±20 % (120 Hz / +20 °C) | | | | | | | | |
| DC leakage current | Please see the attached characteristics list | | | | | | | | |
| Dissipation factor (tan δ) | Please see the attached characteristics list | | | | | | | | |
| Endurance | +105 °C 5000 h, rated voltage applied | | | | | | | | |
| | Capacitance change | Within ±20 % of the initial value | | | | | | | |
| | Dissipation factor (tanδ) | ≤ 150 % of the initial limit | | | | | | | |
| | DC leakage current | Within the initial limit | | | | | | | |
| Damp heat (Steady state) | +60 °C, 90 % to 95 % RH, 1000 h, No-applied voltage | | | | | | | | |
| | Capacitance change | Within ±20 % of the initial value | | | | | | | |
| | Dissipation factor (tanδ) | ≤ 150 % of the initial limit | | | | | | | |
| | DC leakage current | Within the initial limit (after voltage processing) | | | | | | | |

Marking

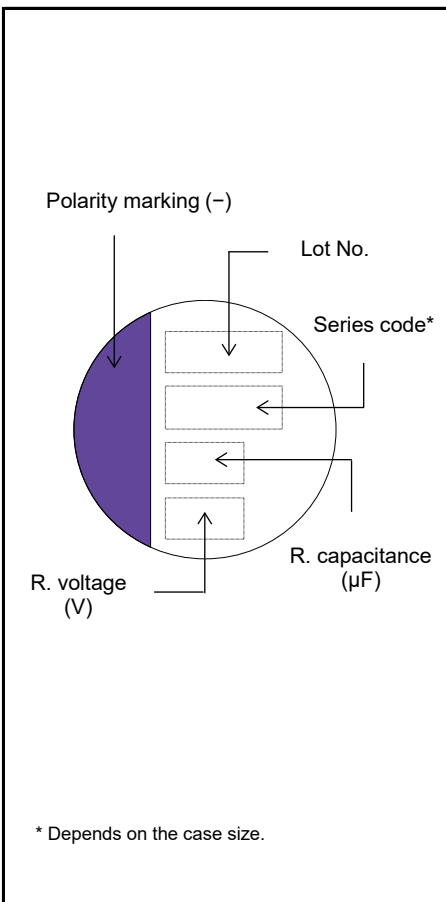

Dimensions (not to scale)

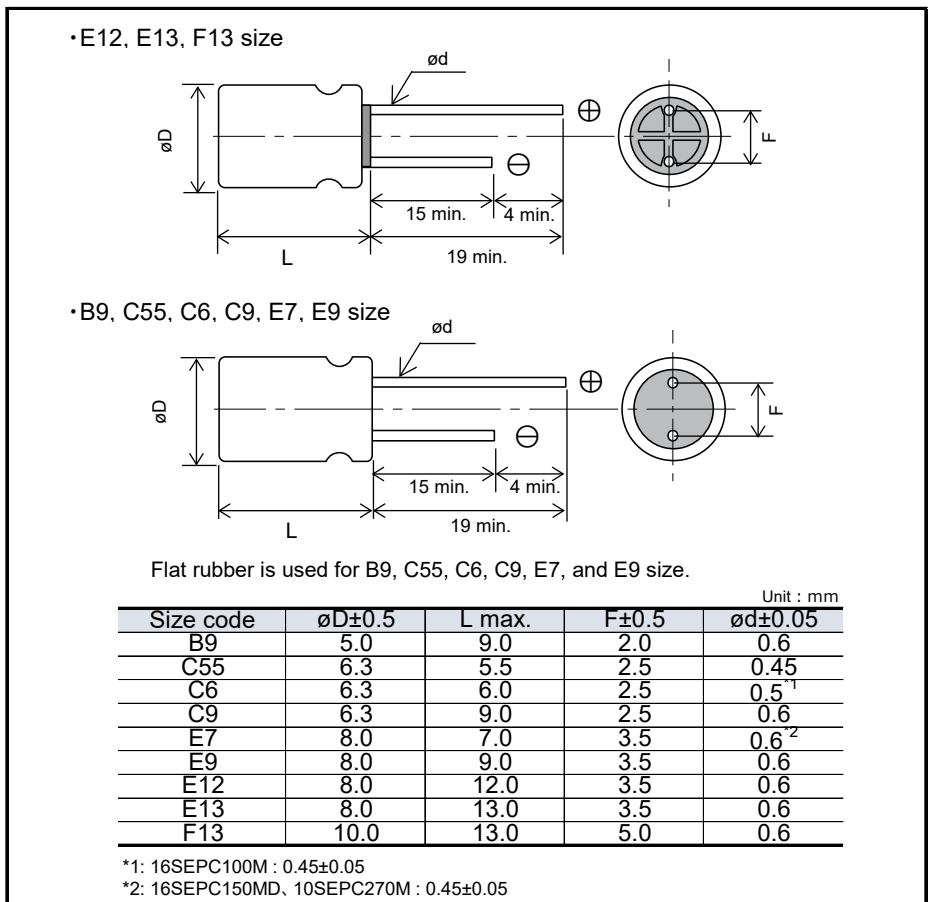

Characteristics list

| Rated voltage (V) | Rated capacitance ($\pm 20\%$) (μF) | Case size (mm) | | Size code | Specifications | | | | Part number Click here for part number list of lead terminal cutting and lead terminal taping |
|-------------------|--|-----------------------|------|-----------|---------------------------------------|-------------------------------------|-----------------------------|------------------------------------|--|
| | | $\varnothing\text{D}$ | L | | Ripple current ^{*1} (mA rms) | ESR ^{*2} (m Ω max.) | $\tan \delta$ ^{*3} | LC ^{*4} (μA) | |
| 2.5 | 100 | 5.0 | 9.0 | B9 | 4180 | 7 | 0.10 | 500 | 2SEPC100MZ |
| | 330 | 5.0 | 9.0 | | 4180 | 7 | 0.10 | 500 | 2SEPC330MZ |
| | 390 | 6.3 | 6.0 | C6 | 3900 | 10 | 0.12 | 500 | 2SEPC390M |
| | 470 | 5.0 | 9.0 | B9 | 4180 | 7 | 0.10 | 500 | 2SEPC470MZ |
| | 560 | 5.0 | 9.0 | | 4180 | 7 | 0.10 | 500 | 2SEPC560MZ |
| | | 6.3 | 6.0 | C6 | 3900 | 10 | 0.12 | 500 | 2SEPC560M |
| | | 6.3 | 9.0 | C9 | 5600 | 7 | 0.10 | 500 | 2SEPC560MW |
| | | 8.0 | 9.0 | E9 | 4700 | 8 | 0.10 | 280 | 2SEPC560MX |
| | 820 | 6.3 | 9.0 | C9 | 5600 | 7 | 0.10 | 500 | 2SEPC820MW |
| | | 8.0 | 7.0 | E7 | 5300 | 8 | 0.10 | 500 | 2SEPC820MD |
| | | 8.0 | 9.0 | E9 | 6100 | 7 | 0.10 | 500 | 2SEPC820MX |
| | | 8.0 | 9.0 | | 7200 | 5 | 0.10 | 500 | 2SEPC820MY |
| | | 8.0 | 13.0 | E13 | 6100 | 7 | 0.10 | 500 | 2R5SEPC820M |
| | 1000 | 8.0 | 9.0 | E9 | 6100 | 7 | 0.10 | 500 | 2SEPC1000MX |
| 2700 | 10.0 | 13.0 | F13 | 5560 | 10 | 0.10 | 1350 | 2SEPC2700M | |
| 4.0 | 560 | 6.3 | 9.0 | C9 | 5600 | 7 | 0.10 | 500 | 4SEPC560MW |
| | | 8.0 | 9.0 | E9 | 6100 | 7 | 0.10 | 500 | 4SEPC560MX |
| | | 8.0 | 13.0 | E13 | 6100 | 7 | 0.10 | 500 | 4SEPC560M |
| | 680 | 8.0 | 13.0 | | 6100 | 7 | 0.10 | 544 | 4SEPC680M |
| | 820 | 10.0 | 13.0 | F13 | 6640 | 7 | 0.10 | 656 | 4SEPC820M |
| 6.3 | 220 | 6.3 | 5.5 | C55 | 2980 | 18 | 0.12 | 280 | 6SEPC220M |
| | 470 | 6.3 | 9.0 | C9 | 5600 | 7 | 0.10 | 592 | 6SEPC470MW |
| | | 8.0 | 9.0 | E9 | 5700 | 8 | 0.10 | 592 | 6SEPC470MX |
| | | 8.0 | 13.0 | E13 | 5700 | 8 | 0.10 | 592 | 6SEPC470M |
| | 560 | 6.3 | 9.0 | C9 | 5600 | 7 | 0.10 | 705 | 6SEPC560MW |
| | | 8.0 | 9.0 | E9 | 6100 | 7 | 0.10 | 705 | 6SEPC560MX |
| | 680 | 10.0 | 13.0 | F13 | 6640 | 7 | 0.10 | 857 | 6SEPC680M |
| | 1000 | 8.0 | 7.0 | E7 | 3530 | 18 | 0.10 | 1260 | 6SEPC1000MD |
| 1500 | 10.0 | 13.0 | F13 | 5560 | 10 | 0.10 | 1890 | 6SEPC1500M | |
| 10 | 270 | 8.0 | 7.0 | E7 | 3220 | 22 | 0.12 | 500 | 10SEPC270MD |
| 16 | 100 | 6.3 | 6.0 | C6 | 2490 | 24 | 0.10 | 320 | 16SEPC100M |
| | | 6.3 | 9.0 | C9 | 4680 | 10 | 0.10 | 500 | 16SEPC100MW |
| | 150 | 8.0 | 7.0 | E7 | 3220 | 22 | 0.12 | 500 | 16SEPC150MD |
| | 180 | 8.0 | 9.0 | E9 | 5000 | 10 | 0.10 | 576 | 16SEPC180MX |
| | | 8.0 | 12.0 | E12 | 4360 | 16 | 0.10 | 576 | 16SEPC180M |
| | 220 | 8.0 | 7.0 | E7 | 4150 | 13 | 0.10 | 500 | 16SEPC220MD |
| | 270 | 8.0 | 9.0 | E9 | 5000 | 10 | 0.10 | 864 | 16SEPC270MX |
| | | 8.0 | 12.0 | E12 | 5000 | 11 | 0.10 | 864 | 16SEPC270M |
| | 470 | 10.0 | 13.0 | F13 | 6100 | 10 | 0.10 | 1504 | 16SEPC470M |

*1: Ripple current (100 kHz / +105 °C)

*2: ESR (100 kHz to 300 kHz / +20 °C)

*3: $\tan \delta$ (120 Hz / +20 °C)

*4: After 2 minutes

◆ Please refer to each page in this catalog for "Flow conditions" and "Taping specifications".

Frequency correction factor for ripple current

| Frequency(f) | 120 Hz \leq f < 1 kHz | 1 kHz \leq f < 10 kHz | 10 kHz \leq f < 100 kHz | 100 kHz \leq f < 500 kHz |
|--------------|-------------------------|-------------------------|---------------------------|----------------------------|
| Coefficient | 0.05 | 0.3 | 0.7 | 1 |

Conductive Polymer Aluminum Solid Capacitors

Radial Lead Type

SEQP series



Features

- High voltage (32 V max.)
- 125 °C 1000 h
- RoHS compliance, Halogen free

Specifications

| Size code | C6 | E7 | E12 | F8 | F13 |
|-----------------------------|--|---|-----------------|-----------------|-------------------|
| Category temp. range | -55 °C to +125 °C | | | | |
| Rated voltage range | 4.0 V to 20 V | 4.0 V to 32 V | | | 4.0 V to 20 V |
| Nominal cap.range | 22 µF to 150 µF | 6.8 µF to 330 µF | 18 µF to 560 µF | 15 µF to 680 µF | 150 µF to 1200 µF |
| Capacitance tolerance | ±20 % (120 Hz / +20 °C) | | | | |
| DC leakage current | Please see the attached characteristics list | | | | |
| Dissipation factor (tan δ) | Please see the attached characteristics list | | | | |
| Endurance | +125 °C 1000 h / +105 °C 5000 h, rated voltage applied | | | | |
| | Capacitance change | Within ±20 % of the initial value | | | |
| | Dissipation factor (tanδ) | ≤ 200 % of the initial limit | | | |
| | DC leakage current | Within the initial limit | | | |
| Damp heat (Steady state) | +60 °C, 90 % to 95 % RH, 1000 h, No-applied voltage | | | | |
| | Capacitance change | Within ±20 % of the initial value | | | |
| | Dissipation factor (tanδ) | ≤ 150 % of the initial limit | | | |
| | DC leakage current | Within the initial limit (after voltage processing) | | | |

Marking

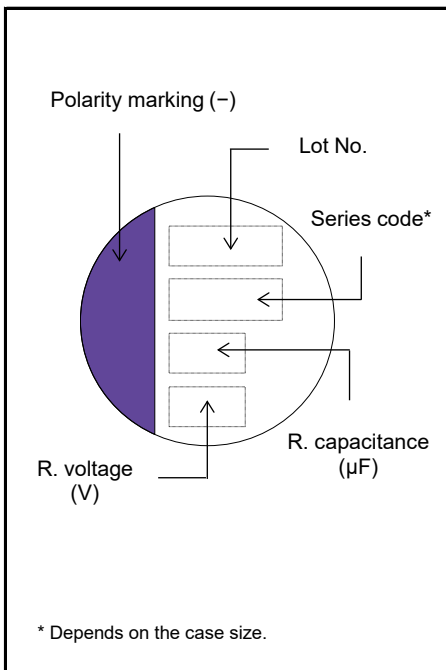

Dimensions (not to scale)

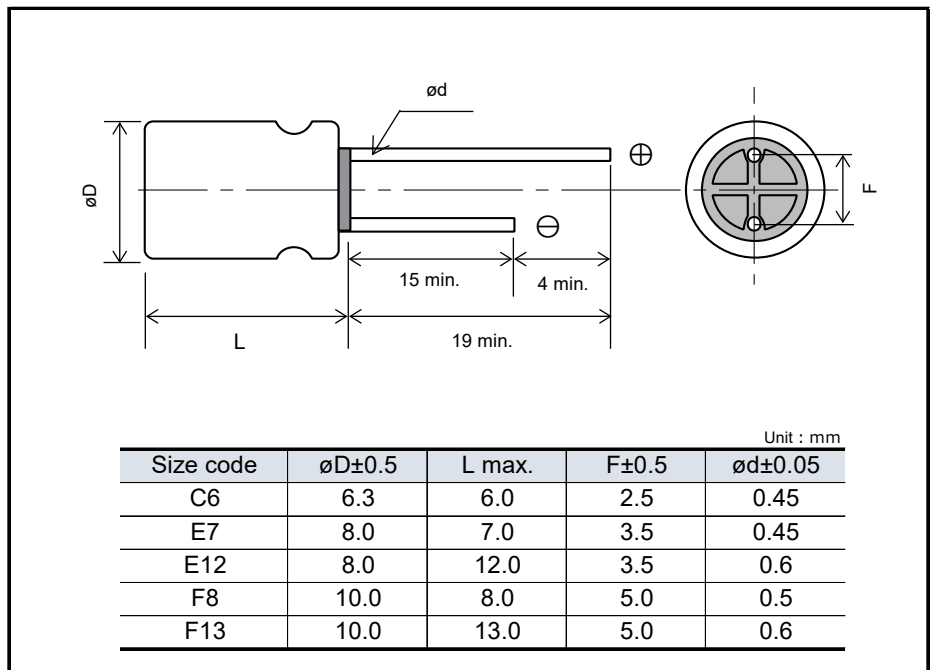

Characteristics list

| Rated voltage (V) | Rated capacitance ($\pm 20\%$) (μF) | Case size (mm) | | Size code | Specifications | | | | | Part number <small>Click here for part number list of lead terminal cutting and lead terminal taping</small> |
|-------------------|--|-----------------------|------|-----------|---------------------------------------|---|-------------------------------------|-----------------------------|------------------------------------|---|
| | | $\varnothing\text{D}$ | L | | Ripple current ^{*1} (mA rms) | Allowable ripple current ^{*1} (mA rms) | ESR ^{*2} (m Ω max.) | $\tan \delta$ ^{*3} | LC ^{*4} (μA) | |
| 4.0 | 150 | 6.3 | 6.0 | C6 | 572 | 1810 | 40 | 0.12 | 300 | 4SEQP150M |
| | 330 | 8.0 | 7.0 | E7 | 810 | 2560 | 35 | 0.12 | 660 | 4SEQP330M |
| | 560 | 8.0 | 12.0 | E12 | 1430 | 4520 | 13 | 0.15 | 448 | 4SEQP560M |
| | 680 | 10.0 | 8.0 | F8 | 1170 | 3700 | 25 | 0.12 | 544 | 4SEQP680M |
| | 1200 | 10.0 | 13.0 | F13 | 1721 | 5440 | 12 | 0.18 | 960 | 4SEQP1200M |
| 6.3 | 82 | 6.3 | 6.0 | C6 | 537 | 1700 | 45 | 0.12 | 258 | 6SEQP82M |
| | 150 | 8.0 | 7.0 | E7 | 810 | 2560 | 35 | 0.12 | 472 | 6SEQP150M |
| | 330 | 10.0 | 8.0 | F8 | 1170 | 3700 | 25 | 0.12 | 416 | 6SEQP330M |
| | 470 | 8.0 | 12.0 | E12 | 1332 | 4210 | 15 | 0.15 | 592 | 6SEQP470M |
| | 820 | 10.0 | 13.0 | F13 | 1721 | 5440 | 12 | 0.15 | 775 | 6SEQP820M |
| 10 | 56 | 6.3 | 6.0 | C6 | 537 | 1700 | 45 | 0.12 | 280 | 10SEQP56M |
| | 120 | 8.0 | 7.0 | E7 | 810 | 2560 | 35 | 0.12 | 600 | 10SEQP120M |
| | 270 | 10.0 | 8.0 | F8 | 1170 | 3700 | 25 | 0.12 | 540 | 10SEQP270M |
| | 330 | 8.0 | 12.0 | E12 | 1250 | 3950 | 17 | 0.15 | 660 | 10SEQP330M |
| | 560 | 10.0 | 13.0 | F13 | 1655 | 5230 | 13 | 0.15 | 840 | 10SEQP560M |
| 16 | 39 | 6.3 | 6.0 | C6 | 512 | 1620 | 50 | 0.10 | 312 | 16SEQP39M |
| | 82 | 8.0 | 7.0 | E7 | 670 | 2120 | 40 | 0.12 | 656 | 16SEQP82M |
| | 150 | 10.0 | 8.0 | F8 | 955 | 3020 | 30 | 0.12 | 480 | 16SEQP150M |
| | 180 | 8.0 | 12.0 | E12 | 1151 | 3640 | 20 | 0.15 | 576 | 16SEQP180M |
| | 330 | 10.0 | 13.0 | F13 | 1493 | 4720 | 16 | 0.15 | 792 | 16SEQP330M |
| 20 | 22 | 6.3 | 6.0 | C6 | 458 | 1450 | 60 | 0.10 | 220 | 20SEQP22M |
| | 47 | 8.0 | 7.0 | E7 | 598 | 1890 | 45 | 0.12 | 470 | 20SEQP47M |
| | 68 | 10.0 | 8.0 | F8 | 759 | 2400 | 40 | 0.12 | 272 | 20SEQP68M |
| | 100 | 8.0 | 12.0 | E12 | 1050 | 3320 | 24 | 0.15 | 400 | 20SEQP100M |
| | 150 | 10.0 | 13.0 | F13 | 1367 | 4320 | 20 | 0.15 | 600 | 20SEQP150M |
| 32 | 6.8 | 8.0 | 7.0 | E7 | 440 | 1400 | 100 | 0.10 | 44 | 32SEQP6R8M |
| | 15 | 10.0 | 8.0 | F8 | 560 | 1800 | 80 | 0.10 | 96 | 32SEQP15M |
| | 18 | 8.0 | 12.0 | E12 | 790 | 2500 | 50 | 0.12 | 115 | 32SEQP18M |

*1: Ripple current (100 kHz / +105 °C < Tx \leq +125 °C) / Allowable ripple current (100 kHz / Tx \leq +105 °C)

*2: ESR (100 kHz to 300 kHz / +20 °C)

*3: $\tan \delta$ (120 Hz / +20 °C)

*4: After 2 minutes

◆ Please refer to each page in this catalog for "Flow conditions" and "Taping specifications".

Frequency correction factor for ripple current

| Frequency(f) | 120 Hz \leq f < 1 kHz | 1 kHz \leq f < 10 kHz | 10 kHz \leq f < 100 kHz | 100 kHz \leq f < 500 kHz |
|--------------|-------------------------|-------------------------|---------------------------|----------------------------|
| Coefficient | 0.05 | 0.3 | 0.7 | 1 |

Conductive Polymer Aluminum
Solid Capacitors
Radial Lead Type
SEP series



Features

- Standard
- 105 °C 3000 h
- RoHS compliance, Halogen free

Specifications

| Size code | C6 | E7 | E12 | F8 | F13 |
|----------------------------|---|---|------------------|-----------------|-------------------|
| Category temp. range | -55 °C to +105 °C | | | | |
| Rated voltage range | 4.0 V to 20 V | | 2.5 V to 20 V | 4.0 V to 20 V | 2.5 V to 20 V |
| Nominal cap.range | 22 µF to 150 µF | 33 µF to 330 µF | 100 µF to 680 µF | 56 µF to 680 µF | 150 µF to 1500 µF |
| Capacitance tolerance | ±20 % (120 Hz / +20 °C) | | | | |
| DC leakage current | Please see the attached characteristics list | | | | |
| Dissipation factor (tan δ) | Please see the attached characteristics list | | | | |
| Endurance | +105 °C 3000 h, rated voltage applied (2.5 V products : 2000 h) | | | | |
| | Capacitance change | Within ±20 % of the initial value | | | |
| | Dissipation factor (tanδ) | ≤ 150 % of the initial limit | | | |
| | DC leakage current | Within the initial limit | | | |
| Damp heat (Steady state) | +60 °C, 90 % to 95 % RH, 1000 h, No-applied voltage | | | | |
| | Capacitance change | Within ±20 % of the initial value | | | |
| | Dissipation factor (tanδ) | ≤ 150 % of the initial limit | | | |
| | DC leakage current | Within the initial limit (after voltage processing) | | | |

Marking

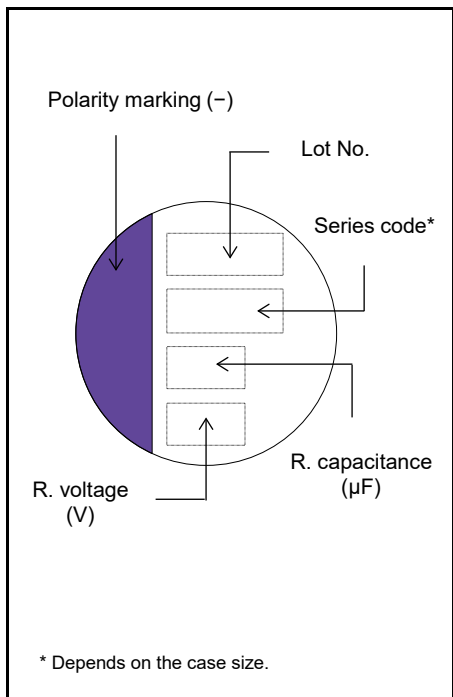

Dimensions (not to scale)

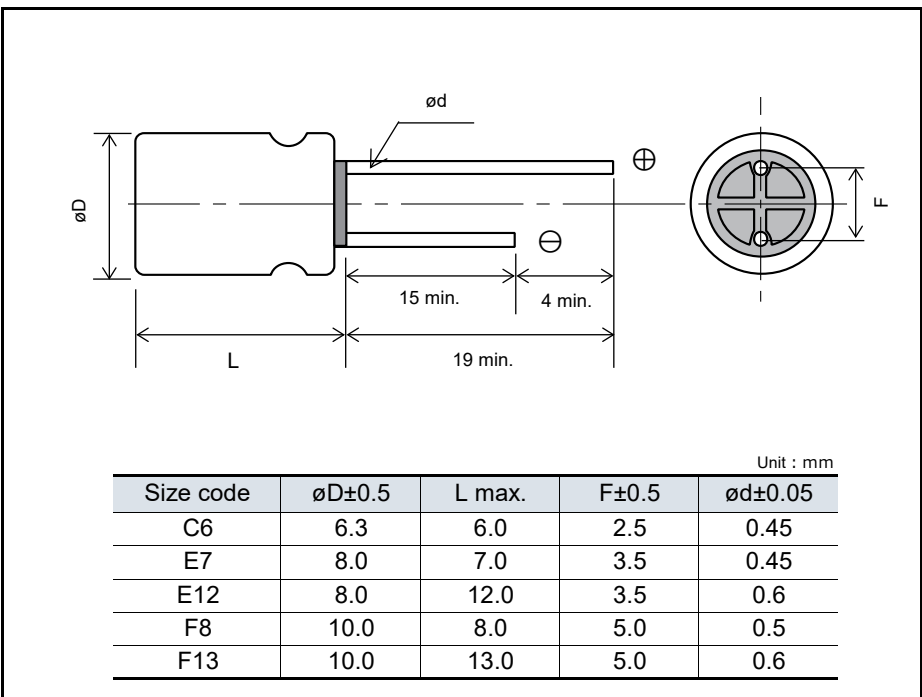

Characteristics list

| Rated voltage (V) | Rated capacitance ($\pm 20\%$) (μF) | Case size (mm) | | Size code | Specifications | | | | Part number Click here for part number list of lead terminal cutting and lead terminal taping |
|-------------------|--|-----------------------|------|-----------|---------------------------------------|-------------------------------------|-----------------------------|------------------------------------|--|
| | | $\varnothing\text{D}$ | L | | Ripple current ^{*1} (mA rms) | ESR ^{*2} (m Ω max.) | $\tan \delta$ ^{*3} | LC ^{*4} (μA) | |
| 2.5 | 680 | 8.0 | 12.0 | E12 | 4520 | 13 | 0.15 | 340 | 2R5SEP680M |
| | 1500 | 10.0 | 13.0 | F13 | 5440 | 12 | 0.18 | 750 | 2R5SEP1500M |
| 4.0 | 100 | 6.3 | 6.0 | C6 | 1810 | 40 | 0.12 | 200 | 4SEP100M |
| | 150 | 6.3 | 6.0 | | 1810 | 40 | 0.12 | 300 | 4SEP150M |
| | 220 | 8.0 | 7.0 | E7 | 2560 | 35 | 0.12 | 440 | 4SEP220M |
| | 330 | 8.0 | 7.0 | | 2560 | 35 | 0.12 | 660 | 4SEP330M |
| | 470 | 10.0 | 8.0 | F8 | 3700 | 25 | 0.12 | 376 | 4SEP470M |
| | 560 | 8.0 | 12.0 | E12 | 4520 | 13 | 0.15 | 448 | 4SEP560M |
| | 680 | 10.0 | 8.0 | F8 | 3700 | 25 | 0.12 | 544 | 4SEP680M |
| | 1200 | 10.0 | 13.0 | F13 | 5440 | 12 | 0.18 | 960 | 4SEP1200M |
| 6.3 | 82 | 6.3 | 6.0 | C6 | 1700 | 45 | 0.12 | 258 | 6SEP82M |
| | 150 | 8.0 | 7.0 | E7 | 2560 | 35 | 0.12 | 472 | 6SEP150M |
| | 330 | 10.0 | 8.0 | F8 | 3700 | 25 | 0.12 | 416 | 6SEP330M |
| | 470 | 8.0 | 12.0 | E12 | 4210 | 15 | 0.15 | 592 | 6SEP470M |
| | 820 | 10.0 | 13.0 | F13 | 5440 | 12 | 0.15 | 775 | 6SEP820M |
| 10 | 56 | 6.3 | 6.0 | C6 | 1700 | 45 | 0.12 | 280 | 10SEP56M |
| | 120 | 8.0 | 7.0 | E7 | 2560 | 35 | 0.12 | 600 | 10SEP120M |
| | 270 | 10.0 | 8.0 | F8 | 3700 | 25 | 0.12 | 540 | 10SEP270M |
| | 330 | 8.0 | 12.0 | E12 | 3950 | 17 | 0.15 | 660 | 10SEP330M |
| | 560 | 10.0 | 13.0 | F13 | 5230 | 13 | 0.15 | 840 | 10SEP560M |
| 16 | 39 | 6.3 | 6.0 | C6 | 1620 | 50 | 0.10 | 312 | 16SEP39M |
| | 82 | 8.0 | 7.0 | E7 | 2120 | 40 | 0.12 | 656 | 16SEP82M |
| | 150 | 10.0 | 8.0 | F8 | 3020 | 30 | 0.12 | 480 | 16SEP150M |
| | 180 | 8.0 | 12.0 | E12 | 3640 | 20 | 0.15 | 576 | 16SEP180M |
| | 330 | 10.0 | 13.0 | F13 | 4720 | 16 | 0.15 | 792 | 16SEP330M |
| 20 | 22 | 6.3 | 6.0 | C6 | 1450 | 60 | 0.10 | 220 | 20SEP22M |
| | 33 | 8.0 | 7.0 | E7 | 1890 | 45 | 0.12 | 330 | 20SEP33M |
| | 47 | 8.0 | 7.0 | | 1890 | 45 | 0.12 | 470 | 20SEP47M |
| | 56 | 10.0 | 8.0 | F8 | 2400 | 40 | 0.12 | 224 | 20SEP56M |
| | 68 | 10.0 | 8.0 | | 2400 | 40 | 0.12 | 272 | 20SEP68M |
| | 100 | 10.0 | 8.0 | | 2570 | 35 | 0.12 | 400 | 20SEP100MX |
| | | 8.0 | 12.0 | E12 | 3320 | 24 | 0.15 | 400 | 20SEP100M |
| | 150 | 10.0 | 13.0 | F13 | 4320 | 20 | 0.15 | 600 | 20SEP150M |

*1: Ripple current (100 kHz / +105 °C)

*2: ESR (100 kHz to 300 kHz / +20 °C)

*3: $\tan \delta$ (120 Hz / +20 °C)

*4: After 2 minutes

◆ Please refer to each page in this catalog for "Flow conditions" and "Taping specifications".

Frequency correction factor for ripple current

| Frequency(f) | 120 Hz \leq f < 1 kHz | 1 kHz \leq f < 10 kHz | 10 kHz \leq f < 100 kHz | 100 kHz \leq f < 500 kHz |
|--------------|-------------------------|-------------------------|---------------------------|----------------------------|
| Coefficient | 0.05 | 0.3 | 0.7 | 1 |

Conductive Polymer Hybrid Aluminum Electrolytic Capacitors

Hybrid

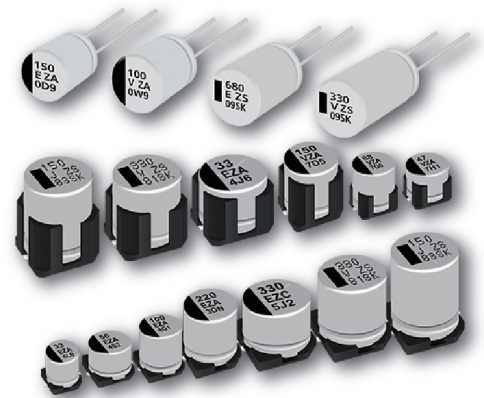

INDEX

| | |
|-----------------------------------|------|
| Application Guidelines (Hybrid) | P153 |
| Line-up / Diagram | P159 |
| Voltage - Capacitance table | P161 |
| Explanation of part numbers | P163 |
| Mounting / Packing specifications | P165 |
| Each series | P167 |

Applications

Main market

Communications infrastructure



Automotive

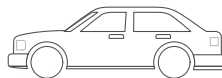

Industrial equipment

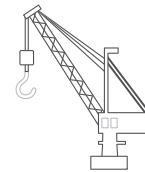

Desktop computer



Audio / Visual

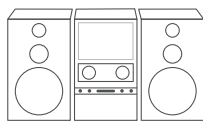

Server

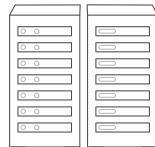

Home appliance

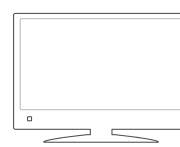

Industrial robot

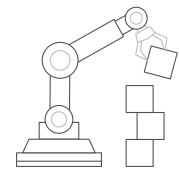

Matters to Be Observed When Using This Product

(Conductive polymer hybrid aluminum electrolytic capacitor / Aluminum electrolytic capacitor)

Use environments and cleaning conditions

- This product (capacitor) is intended for standard general-purpose use in electronic equipment, and is not designed for use in the specific environments described below. Using the product in such specific environments or service conditions, therefore, may affect the performance of the product.
Check with us about the performance and reliability of the product first before using the product.

- (1) Used at a temperature higher than the upper limit category temperature or lower than the lower limit category temperature.
- (2) Used in an environment where the product is directly exposed to water, salt water, oil, etc., or in a liquid, such as water, oil, chemicals, and organic solvents.
- (3) Used in an outdoor environment where the product is exposed to direct sunlight, ozone, radiation, UV-rays, etc., or in a dusty place.
- (4) Used in a wet place (dew concentration on a resistor, water leakage, etc.), a place exposed to sea breeze, or a place filled with a corrosive gas, such as Cl₂, H₂S, NH₃, SO₂, or NO_x.
- (5) Used in an environment filled with a toxic gas (hydrogen sulfide, sulfurous acid, nitrous acid, chlorine and chlorine compound, bromine and bromine compound, ammonia, etc.)
- (6) Used in an environment where static electricity and electromagnetic waves are strong.
- (7) Located close to heating component or a flammable material, such as a vinyl cable.
- (8) Sealed with a resin, etc.
- (9) Cleansed with a solvent, water, or a water-soluble cleaner, to remove solder flux after soldering.
- (10) Used in an environment where an acidic or alkali atmosphere is present.
- (11) Used in an environment where excessive vibration or mechanical shocks exceeding a specified range is applied to the product (even if the applied vibration or mechanical shocks is within the specified range, it may cause the product to resonate, in which a large vibration acceleration may be generated. Make sure to evaluate/check such vibrations or mechanical shocks applied to the product in an actual condition).

Panasonic Industry's conditions for vibration test are shown in the table below. Random waveform is not guaranteed. For radial type, datasheet is also available if requested.

| Item | Standard | Vibration-proof |
|-------------------|-----------------------------|-----------------------------|
| Waveform | Sine | Sine |
| Frequency | 10 - 55 Hz | 5 - 2000 Hz |
| Direction | X, Y, Z axis | X, Y, Z axis |
| Duration | 2 hours each direction | 2 hours each direction |
| Max p-p amplitude | 1.5mm _{pp} | 5mm _{pp} |
| Max acceleration | 90 m/s ² (9.1 G) | 294 m/s ² (30 G) |

- (12) Used under a low atmospheric pressure condition or depressurized condition.
- The capacitor withstands an immersion cleaning process where the board carrying the product is immersed in a cleaning solution of 60 °C or lower for less than 5 minutes and withstands an ultrasonic cleaning process as well. However, ensure to thoroughly rinse and dry it. Some cleaning methods erase or blur notes on the capacitor in some cases. Some types of capacitors are not washable and some cleaning solutions cannot be used to clean a capacitor. The following water-base solvents have been validated for cleaning. Contact a sales representative for more information.
Pine Alpha ST-100S, Cleanthrough 750H/750L/710M
 - Keep the cleaning solution under strict contamination control (conductivity, pH, specific gravity, water content, etc.). A contaminated cleaning solution will show a high chlorine concentration, thereby corroding the interior of the capacitor in some cases. Keep the flux concentration in the cleaning solution at a 2% mass or less.
 - Unless otherwise specified in the specifications, avoid cleaning the capacitor with a halogen-based solvent, an alkaline solvent, a petroleum-based solvent, xylene, or acetone. Using a halogen-based solvent may result in a case where the solvent infiltrates (leaks) into the capacitor and break-down releasing chlorine, which reacts with aluminum which can corrode the capacitor interior. 1-1-1 trichloroethane is particularly harmful to a capacitor. Never use it to clean a capacitor. A alkaline solvent may corrode (dissolve) an aluminum case, a petroleum-based solvent and xylene may damage the sealing rubber and accelerate its deterioration, and acetone may erase notes on the capacitor.
To protect the global environment, refrain from using an ozone depleting substance as the cleaning solution.
 - Right after the board cleaning, subject the capacitor to a forced drying process so that no cleaning solution remains between the sealing part of the capacitor and the printed board.
Set a drying temperature equal to or lower than the upper limit category temperature.

- When an adhesive or coating agent is used to fix the capacitor and prevent dampening of the board, specific types of solvents included in some adhesives or coating agents may corrode the capacitor. Select a non-halogen solvent for the material making up the adhesive or coating agent. Do not use a chloroprene-based polymer. Solidify and dry the adhesive or coating agent sufficiently to prevent its solvent component from remaining on the capacitor. Leave at least 1/3 of the sealing part unsealed on the surface to which the adhesive or coating agent is applied.
- Do not use the product in a structure sealed by potting or molding. The pressure of a molding resin on a capacitor may deform the capacitor. In addition, the resin covering the capacitor may affect its heat dissipation performance or may leak into the product. These factors lead to the significant degradation of the capacitor's characteristics and reliability. There is also a concern that an electrolytic solution permeating the sealing rubber may agglomerate and cause a short circuit.
- When the capacitor is used in a circuit where an impact voltage is applied or a high voltage is applied in a short period (transient phenomenon) or a high pulse voltage is applied, make sure to use the capacitor at a voltage equal to or lower than its rated voltage.
- The product contains an electrolytic. Improper use of the capacitor leads not only to the rapid degradation of its characteristics but also to electrolytic leakage. These problems damage the circuit board and may lead to destruction of the entire circuit set.

Response to anomalies and handling conditions

- When you see gas coming out of an activated pressure relief valve of a capacitor during use of a circuit set, turn off the main power supply of the circuit set or pull the power cord plug out of the wall-outlet. If you leave the power supply on and the capacitor short-circuits, it will damage the circuit, or the gas can turn into a liquid, which will cause the circuit to short. In the worst case scenarios, these events may develop into a more serious incident, such as burnout of the circuit set. The gas coming out of the pressure relief valve of a capacitor is not smoke, but is the electrolytic solution in its gaseous state.
- When the pressure valve of the capacitor is activated, it emits a high-temperature gas of over 100 °C. Do not bring your face near the valve. In case the gas jetting out of the valve gets in your eyes or comes into your mouth, wash your eyes with water or rinse your mouth immediately. If the gas hits your skin, wash it away with soap.
- If you touch a terminal of the product during use of the circuit set, you will get an electric shock. The aluminum case of the product has an exposed part with no insulation. Do not touch the exposed part because it is as dangerous as the terminal.
- Do not create a short circuit between terminals of the product by inserting a conductor therebetween. Do not splash a conductive solution, such as an acidic or alkali solution, on the capacitor. It puts the capacitor in a shorted state, which causes the circuit to fail and destroys the capacitor as well.
- When a silicone material containing a relatively large amount of a low-molecular-weight siloxane is located close to the product, it may cause the capacitor problems with its electrical performance.
- When electronic equipment having the capacitor built therein is exported to overseas markets, wooden packaging materials are fumigated with a halogen compound, such as methyl bromide. In such cases, if the packaging material subjected to the fumigation treatment is not dried sufficiently, halogen remaining on the packaging material may leach into the capacitor during transportation and trigger a corrosive reaction in the capacitor. When carrying out the fumigation treatment, carefully examine the dried packaging material to confirm that no halogen remains on the packaging material. Never fumigate the entire electronic equipment in its packaged state.

Reliability and product life

- The product life is affected by temperatures. In general, a 10 °C drop in the temperature will double the life. Use the capacitor at a temperature as low as possible from the upper limit category temperature.
- Using a capacitor under a temperature condition outside a specified temperature range causes heavy degradation of the capacitor characteristics, which may result in breakage of the capacitor. You need to confirm not only the ambient temperature and internal temperature of the capacitor but also the temperature of the capacitor's top surface, which is given by radiant heat from built-in heating elements (a power transistor, IC, resistance, etc.) and heat generated by self-heating induced by ripple current. Do not place a heating element on the back of the capacitor.

- The product life is given by the following equation.

$$L2 = L1 \times 2^{\frac{T1-(T2+\Delta T)}{10}} \quad \text{Where } T1 \geq T2$$

- L1 : Guaranteed life (h) at temperature T1 (°C)
- L2 : Expected life (h) at temperature T2 (°C) * In the case of a hybrid type, category temperature (°C)
- T1 : Upper category temperature (°C) + temperature increase caused by rated ripple current (°C)
- T2 : Ambient temperature of capacitor (°C)
- ΔT : Temperature increase caused by ripple current (°C)

- Do not use the product for a period longer than its specified service life. A capacitor with its service life ended may cause the following problems: rapid degradation of the product characteristics, short circuit, unnecessary activation of the pressure valve, electrolytic solution leakage, etc. Note that the estimated service life is not longer than 15 years due to the limited environment-resistant property of the sealing rubber.
- When the capacitor is used under a high-temperature condition for a long period, minute cracks develop on the surface of the sealing rubber or the case surface turns brown in some cases. These phenomena, however, have no effects on the reliability of the capacitor.
- A capacitor conforming to "AEC-Q200" refers to a capacitor having passed some or all of evaluation test items defined in AEC-Q200.
To know the detailed specifications of each capacitor or specific evaluation test scores, please contact us.
We issue a the product specifications sheet for each product ordered. Please confirm the product specifications sheet when you place an order to us.

Circuit design and circuit board design

- The electrical characteristics change as a result of temperature/frequency fluctuations. Take electrical characteristic changes into consideration when working out a circuit design.
 - (1) Temperature fluctuations
 - High-temperature condition : increase in leak current
 - Low-temperature condition : decrease in capacitance, increase in the tangent to the loss angle, increase in impedance (the hybrid type is excluded), etc.
 - (2) Frequency fluctuations
 - High-frequency condition : decrease in capacitance, increase in the tangent to the loss angle, decrease in impedance, etc.
 - Low-frequency condition : more heat generation by ripple current as a result of an increase in equivalent series resistance
- The group of factors described below may lead to rapid degradation of the capacitor characteristics, short circuit, or electrolytic solution leakage. They may give rise to sharp heat/gas generation, too, in which case the increasing internal pressure actuates the pressure valve, causes the electrolytic solution to leak out of the sealing part, and, in a worst-case scenario, causes an explosion or ignition incident. When a capacitor bursts, it may scatter flammable materials (electrolytic solution, etc.) in its surroundings.
 - (1) Reverse voltage: The capacitor has preset polarity. Do not apply a reverse voltage to the capacitor.
Confirm the polarity indicated on the capacitor and then use it.
 - (2) Charge/discharge: Avoid using the capacitor in a circuit that frequently repeats sharp charge/discharge cycles or a circuit that requires relatively slow but highly frequent charge/discharge cycles. In cases where you use the capacitor in such circuits, make sure to inform us of the charge/discharge conditions.
Ensure that a rush current does not exceed 100 A.
 - (3) ON/OFF: Avoid using the capacitor in an on/off circuit that repeatedly switches on and off more than 10,000 times a day. In cases where you use the product in such circuits, make sure to inform us of the circuit conditions, etc.
 - (4) Overvoltage: Do not apply an overvoltage higher than the rated voltage (higher than the surge voltage when the voltage application period is short). A peak value given by superposing a ripple voltage (AC component) on a DC voltage must be equal to or lower than the rated voltage.
 - (5) Ripple current: Do not allow an excessively large ripple current (larger than the rated ripple current specified in the specifications) to flow through the capacitor. Even if a ripple current flow in the capacitor is equal to or smaller than the rated ripple current, a reverse voltage flow may be generated in the capacitor when the DC bias voltage is low flow in the capacitor. Keep the ripple current flow within a range in which no reverse voltage is generated.
Even if the ripple current flow is kept equal to or smaller than the rated ripple current, using the capacitor for a period longer than its service life intensifies the degradation of the ESR characteristics, resulting in an increase in internal heating caused by the ripple current. As a result, the pressure valve is actuated, the exterior case or rubber swells, the electrolytic solution leaks, and, in a worst-case scenario, the capacitor short-circuits and ignites or explodes.

- Because the impedance of the capacitor is close to the circuit impedance, capacitors connected in parallel in the circuit may damage the whole current balance, in which, a ripple current higher than the rated ripple current may flow in some of the capacitors. To prevent concentration of ripple current on the low-impedance side, use capacitors with the same part number and avoid the partiality of cable impedances. Do not use capacitors connected in series.
- When the capacitor is mounted on a double-side wiring board, do not place the wiring pattern directly underneath where the product is mounted. In case the electrolytic solution leaks out, it may short-circuit the pattern and cause tracking or migration. Consider a case where the product is a radial lead capacitor and is mounted on a board with through-holes. In this case, if the sealing part of the capacitor and the board surface stick close to each other, solder flows up to the capacitor during a dip soldering process, which may cause short circuit between the anode and cathode of the capacitor. In such a case, the outer laminate of the product may be damaged. The position of holes, therefore, must be determined properly.
- When designing a printed board carrying radial lead capacitors, make through-holes across the gap equal to the gap between the leads (terminals) of the capacitor. If the gap between the through-holes is narrower or wider than the gap between the leads, stress is applied to the leads when the capacitor is inserted in the holes. This may result in increasing leak current, short circuit, wire breaking, or electrolytic solution leakage.
- A capacitor which has the pressure valve on the case must be provided with a space formed above the pressure valve so that the pressure valve operates without hinderance. When the product is 6.3 mm to 16 mm in diameter, form a space of 2 mm or larger. When the product is 18 mm in diameter, form a space of 3 mm or larger. If the space is not large enough, it will impair the operability of the pressure valve and may lead to an explosion incident.
- Design the circuit in such that the pattern, especially a line pattern carrying high voltage or large current, is not formed above the pressure valve. Upon its activation, the pressure valve emits a flammable high-temperature gas of over 100 °C. This may cause a secondary accident, such as the gas condensing on the pattern and the wire sheathing being melted and catching on fire.
- Be careful with resonance of the capacitor mounted on the board. When a large load is applied to the capacitor at the frequency close to the resonance frequency, it may cause the capacitor to come off or widely change its characteristics.
- Completely isolate the case of the capacitor from the cathode terminal and the circuit pattern.
- The laminate or outer sleeve covering of the product is for displaying information on the product and does not have a guaranteed insulating function. The laminate may turn brown under a high-temperature condition. However, that does not cause problems with markings recognition on the product surface or electrical performance. The outer sleeve may crack when dipped in a xylene or toluene solution and exposed to high temperature.

Mounting conditions

- Do not reuse a capacitor that was incorporated in a circuit set and energized in the past. Do not use a capacitor that was dropped on the floor. Do not use a capacitor in its compressed form. Compressing the capacitor makes it less airtight, resulting in poor performance, shorter guaranteed life, and electrolyte leakage.
- A re-striking voltage is generated in a capacitor in some cases. In such a case, let the capacitor discharge through a resistor of about 1 k Ω .
- When a capacitor is kept in storage for a long period, you may find the leak current from the capacitor has increased. In such a case, make voltage adjustment through a resistor of about 1 k Ω .
- Before mounting the capacitor on the board, confirm the ratings (capacitance, rated voltage, etc.) and polarity of the capacitor. Before mounting a surface-mounted type capacitor, confirm its terminal dimensions and land size. Before mounting a radial lead type capacitor, confirm its terminal interval and hole interval. If the terminal interval is not the specified one, stress is applied to internal elements, which may cause problems, such as a short circuit and insufficient mounting strength. When the terminal interval and the hole interval of the radial lead type capacitor do not match and therefore the capacitor's leads need to be readjusted, make sure that the readjustment does not apply any stress to the capacitor's body.

- Confirm the applied pressure when using an automatically mounting process for a surface-mounted type capacitor. Excessive pressure may result in increasing leak current, short circuit, the capacitor coming off from the board, and the like. When automatically mounting the radial lead type capacitor, check the wear of a cutter for cutting the leads and confirm that the angle of clinching the leads is not too acute with regards to the board. Clinching the leads at too acute of an angle applies tensile stress to the leads, which may lead to destruction of the capacitor.
- Follow soldering conditions (preheating, soldering temperature/time, the number of soldering, etc.) in the specification sheet. A high peak temperature or a long heating time causes the degradation of electrical characteristics or a reduction in the guaranteed life. Note that the specified soldering conditions indicate conditions under which the degradation of capacitor characteristics do not occur but do not indicate conditions under which stable soldering can be performed. Check and set conditions under which stable soldering can be performed, on a case-by-case basis. Measure the temperature of the capacitor, using a thermocouple bonded to the top of the capacitor with an epoxy-based adhesive. This temperature measurement must be conducted in a mass-production setup.
- The surface-mounted type capacitor is soldered by reflow soldering only. It cannot be soldered by flow soldering or dip soldering. Carry out reflow soldering with an atmospheric heat transfer method using infrared hot air, etc. When carrying out two rounds of reflow processes, carry out the second reflow process after the capacitor's temperature settles down to a normal temperature. In the case of VPS reflow, a sharp rise in the capacitor temperature causes a change in the characteristics and appearance of the capacitor, which may give rise to a problem with capacitor mounting. We therefore recommend execution of VPS flow at a temperature rise rate of 3 °C/second or lower. For more information about this matter, please contact us.
- Reflow soldering, under the reflow conditions we recommend, might result in discoloring or swelling of the case or crack formation on the ink mark indicating the cathode. These minor problems, however, do not affect the reliability of the capacitor at all.
- A 6.3-mm diameter vibration-resistant capacitor has a structure that covers the auxiliary terminals to the sides of a seat plate. In cases where you confirm formation of a fillet on the sides of the auxiliary terminals by an image recognition means, etc., examine soldering conditions for the formation of a sufficient fillet on the auxiliary terminals in advance before carrying out the soldering process. Even if the formation of a sufficient fillet on the auxiliary terminals is not confirmed, a solder junction between the lower surface of the auxiliary terminals and the board ensures vibration-resistant performance, meaning the reliability of the capacitor is not affected.
- The radial lead type capacitor cannot be soldered by reflow soldering. Do not dip the capacitor body, except the leads, in solder. Heat from the solder raises the internal pressure of the capacitor and destroys it. Solder the capacitor according to the following soldering conditions: soldering temperature of 260 °C ±5 °C and soldering time of 10 seconds ±1 second.
- Ensure that other components do not come in contact with the capacitor during the soldering process. When a radial lead type capacitor is set in close contact with the board, check the soldered state of the capacitor well, because its sealing rubber has no venting structure.
- When manually soldering the capacitor, follow the soldering conditions (soldering temperature/time) specified in the specification sheet or adopt a soldering temperature of 350 °C and a soldering time of 3 seconds or less. When you need to remove a capacitor already soldered, remove it after the solder is melted sufficiently so that no stress is applied to the terminals of the capacitor. Be careful not to let the solder iron tip touch the capacitor. The solder iron touching the capacitor may damage the capacitor.
- When the temperature of the capacitor becomes extremely high due to preheating, solidification of the setting resin, etc., may cause the outer sleeve of the capacitor to shrink or crack. When treating the capacitor in a thermosetting furnace, etc., place the capacitor in an atmosphere of 150 °C for 2 minutes or less.
- Do not tilt or twist the capacitor soldered to a printed board or hold the capacitor to carry the board or hit the capacitor against something. Such actions apply a force to the internal elements through the terminals and may destroy the product.
- Using highly active halogenous (chlorine-based or bromic) solder flux poses a concern that residual solder flux will have negative impact on the performance and reliability of the capacitor. Check the influence of residual solder flux before using such solder flux.

Storage conditions

- A capacitor left for a long period is prone to have a greater flow of leak current. This happens because the oxide film deteriorates under a no-load condition. Voltage application to the capacitor reduces the leak current. However, at the start of voltage application, a large flow of film recovery current increases the leak current, which may cause a circuit failure, etc.
- The storage period of a capacitor is 42 months from the shipment inspection day. However, the storage period of capacitors not listed in the following table is specified as 12 months. Store the capacitor in a place where a normal temperature condition (5°C to 35°C) and a normal humidity condition (45% to 85%) are maintained and direct sunlight is blocked.

| Product category | Series | Storage period |
|---|--|--|
| Hybrid type | All hybrid series | 42 months from the shipment inspection day |
| Surface-mounted type other than the hybrid type | S (hot lead-free reflow), HA (hot lead-free reflow) HB (hot lead-free reflow, 5.4 mm in height) HC, HD, FCA, FC, FKA, FK, FKS, FP, FT, FH, FN TG, TK, TP, TC, TCU, TQ | |
| Radial lead type other than the hybrid type | FC-A, FK-A, HD-A, TA-A, TP-A, FP-A | |

- Avoid storing the capacitor in environments not specified in the delivery specification sheet or in the following environments or conditions.
 - (1) Used at a temperature higher than the upper limit category temperature or lower than the lower limit category temperature
 - (2) Environments where the capacitor is exposed to water, salt water, or oil
 - (3) Environments where dew concentrates on the capacitor
 - (4) Environments filled with a toxic gas (hydrogen sulfide, sulfurous acid, nitrous acid, chlorine and chlorine compound, bromine and bromine compound, ammonia, etc.)
 - (5) Environments where the product is exposed to ozone, radiation, UV-rays, etc.
 - (6) Environments where vibrations or mechanical shocks exceeding a specified range is applied to the capacitor

Reference information

Guidelines

Some of the product use guidelines described herein are excerpted from JEITA RCR-2367D "Safety application guide for fixed aluminum electrolytic capacitors for use in electronic equipment," a technical report issued by the Japan Electronics and Information Technology Industries Association on October 2017. For more detailed information, please see the above technical report.

Intellectual property

Panasonic Group provides customers with safe products and services. We are also making great efforts to protect our intellectual property rights for Panasonic Group products. Typical patents related to this product are as follows. (Hybrid type)

[U.S. patent]

USP Nos. 7497879, 7621970, 9208954, 9595396, 9966200, 10453618, 10559432, 10679800, 10685788, 10790095, 10262806, 10896783, 11348739, 11094471, 12062501, 10563318, 10865494, 10373763

Lineup

Surface mount type

| Series | Part No. | Features | Small size | Large cap. | High ripple | High temp. | Long life | Category temperature range (°C) | Rated voltage range (V) | ESR (mΩ) | Capacitance range (μF) | Size code | Size (mm) | |
|----------|------------|--|------------|------------|-------------|------------|------------|---------------------------------|-------------------------|-------------|------------------------|-----------|-----------|------|
| | | | | | | | | | | | | | øD | L |
| ZA | EEHZA--- | Low ESR High ripple current Long life 105 °C 10000 h | ● | | | | | -55 to 105 | 25 to 50 | 80 to 120 | 10 to 33 | C | 5.0 | 5.8 |
| | | | | | | | | | 25 to 63 | 50 to 120 | 10 to 56 | D | 6.3 | 5.8 |
| | | | | | | | | | | 30 to 80 | 22 to 100 | D8 | 6.3 | 7.7 |
| | | | | | | | | | 25 to 80 | 27 to 45 | 22 to 220 | F | 8.0 | 10.2 |
| 20 to 36 | 33 to 330 | G | 10.0 | 10.2 | | | | | | | | | | |
| ZC | EEHZC--- | Low ESR High ripple current Long life 125 °C 4000 h | ● | | | | -55 to 125 | 25 to 50 | 80 to 120 | 10 to 33 | C | 5.0 | 5.8 | |
| | | | | | | | | 25 to 63 | 50 to 120 | 10 to 56 | D | 6.3 | 5.8 | |
| | | | | | | | | | 30 to 80 | 22 to 100 | D8 | 6.3 | 7.7 | |
| | | | | | | | | 25 to 80 | 27 to 45 | 22 to 220 | F | 8.0 | 10.2 | |
| 20 to 36 | 33 to 330 | G | 10.0 | 10.2 | | | | | | | | | | |
| ZK | EEHZK--- | Large capacitance High ripple current Long life 125 °C 4000 h | ● | ● | ● | | -55 to 125 | 25 to 35 | 80 to 100 | 33 to 47 | C | 5.0 | 5.8 | |
| | | | | | | | | | 50 to 60 | 56 to 82 | D | 6.3 | 5.8 | |
| | | | | | | | | | 30 to 35 | 100 to 150 | D8 | 6.3 | 7.7 | |
| | | | | | | | | | 27 | 180 to 270 | F | 8.0 | 10.2 | |
| ZKU | EEHZK--U- | Large capacitance Long life 125 °C 4000 h | ● | ● | ● | | -55 to 125 | 25 to 35 | 80 to 100 | 39 to 56 | C | 5.0 | 5.8 | |
| | | | | | | | | | 50 to 60 | 68 to 100 | D | 6.3 | 5.8 | |
| | | | | | | | | | 30 to 35 | 120 to 180 | D8 | 6.3 | 7.7 | |
| | | | | | | | | | 27 | 220 to 330 | F | 8.0 | 10.2 | |
| ZL | EEHZL--- | 125 °C 4000 h 135 °C 4000 h | ● | ● | ● | | -55 to 135 | 25 to 35 | 58 to 60 | 47 to 82 | C | 5.0 | 5.8 | |
| | | | | | | | | | 38 to 40 | 82 to 150 | D | 6.3 | 5.8 | |
| | | | | | | | | | 24 to 26 | 150 to 220 | D8 | 6.3 | 7.7 | |
| | | | | | | | | | 18 to 20 | 270 to 470 | F | 8.0 | 10.2 | |
| ZT | EEHZT--- | 125 °C 4000 h 135 °C 4000 h | ● | ● | | | -55 to 135 | 25 to 63 | 14 to 16 | 470 to 680 | G | 10.0 | 10.2 | |
| | | | | | | | | | 22 to 32 | 33 to 220 | F | 8.0 | 10.2 | |
| | | | | | | | | | 16 to 25 | 56 to 330 | G | 10.0 | 10.2 | |
| | | | | | | | | | 25 to 35 | 22 | 220 to 330 | F | 8.0 | 10.2 |
| 16 | 390 to 560 | G | 10.0 | 10.2 | | | | | | | | | | |
| ZV | EEHZV--- | 125 °C 4000 h 135 °C 4000 h | ● | ● | | | -55 to 135 | 25 to 63 | 16 to 22 | 33 to 220 | F | 8.0 | 10.2 | |
| | | | | | | | | | 12 to 17 | 56 to 330 | G | 10.0 | 10.2 | |
| ZVU | EEHZV--U- | 125 °C 4000 h 135 °C 4000 h | ● | ● | | | -55 to 135 | 25 to 63 | 16 to 22 | 56 to 330 | F | 8.0 | 10.2 | |
| | | | | | | | | | 12 to 17 | 100 to 560 | G | 10.0 | 10.2 | |
| ZS | EEHZS--- | 125 °C 4000 h 135 °C 4000 h | ● | ● | | | -55 to 135 | 25 to 63 | 14 to 19 | 100 to 470 | G12 | 10.0 | 12.5 | |
| | | | | | | | | | 11 to 15 | 150 to 560 | G16 | 10.0 | 16.5 | |
| ZSU | EEHZS--U- | 125 °C 4000 h 135 °C 4000 h | ● | ● | | | -55 to 135 | 25 to 63 | 14 to 19 | 120 to 680 | G12 | 10.0 | 12.5 | |
| | | | | | | | | | 11 to 15 | 180 to 1000 | G16 | 10.0 | 16.5 | |
| ZU | EEHZU--- | 125 °C 4000 h 135 °C 4000 h | ● | ● | | | -55 to 135 | 25 to 63 | 10 to 12 | 100 to 470 | G12 | 10.0 | 12.5 | |
| | | | | | | | | | 8 to 10 | 150 to 560 | G16 | 10.0 | 16.5 | |
| ZUU | EEHZU--U- | 125 °C 4000 h 135 °C 4000 h | ● | ● | | | -55 to 135 | 25 to 63 | 10 to 12 | 120 to 680 | G12 | 10.0 | 12.5 | |
| | | | | | | | | | 8 to 10 | 180 to 1000 | G16 | 10.0 | 16.5 | |
| ZE | EEHZE--- | 145 °C 2000 h 135 °C 4000 h | | | | ● | ● | -55 to 145 | 25 to 63 | 27 to 40 | 33 to 220 | F | 8.0 | 10.2 |
| | | | | | | | | | 20 to 30 | 56 to 330 | G | 10.0 | 10.2 | |
| ZF | EEHZF--- | 150 °C 1000 h | | | | ● | ● | -55 to 150 | 25 to 63 | 27 to 40 | 33 to 150 | F | 8.0 | 10.2 |
| | | | | | | | | | 20 to 30 | 56 to 270 | G | 10.0 | 10.2 | |

Line up

Radial lead type

| Series | Part No. | Features | Small size | Large cap. | High ripple | High temp. | Long life | Category temperature range (°C) | Rated voltage range (V) | ESR (mΩ) | Capacitance range (μF) | Size code | Size (mm) | |
|--------|------------|----------------|------------|------------|-------------|------------|-----------|---------------------------------|-------------------------|----------|------------------------|-----------|-----------|------|
| | | | | | | | | | | | | | ∅D | L |
| ZA-A | EEHAZA---B | 105 °C 10000 h | | | | | | -55 to 105 | 25 to 80 | 27 to 45 | 22 to 220 | F | 8.0 | 9.5 |
| | | | | | | | | | | 20 to 36 | 33 to 330 | G | 10.0 | 9.5 |
| ZC-A | EEHAZC---B | 125 °C 4000 h | | | | | ● | -55 to 125 | 25 to 80 | 27 to 45 | 22 to 220 | F | 8.0 | 9.5 |
| | | | | | | | | | | 20 to 36 | 33 to 330 | G | 10.0 | 9.5 |
| ZK-A | EEHAZK---B | 125 °C 4000 h | | ● | ● | | | -55 to 125 | 25 to 35 | 27 | 180 to 270 | F | 8.0 | 9.5 |
| | | | | | | | | | | 20 | 330 to 470 | G | 10.0 | 9.5 |
| ZKU-A | EEHAZK--UB | 125 °C 4000 h | | ● | ● | | | -55 to 125 | 25 to 35 | 27 | 220 to 330 | F | 8.0 | 9.5 |
| | | | | | | | | | | 20 | 390 to 560 | G | 10.0 | 9.5 |
| ZT-A | EEHAZT---B | 125 °C 4000 h | | ● | ● | | | -55 to 135 | 25 to 63 | 22 to 32 | 33 to 220 | F | 8.0 | 9.5 |
| | | 135 °C 4000 h | | | | | | | | 16 to 25 | 56 to 330 | G | 10.0 | 9.5 |
| ZS-A | EEHAZS---B | 125 °C 4000 h | | ● | ● | | | -55 to 135 | 25 to 63 | 14 to 19 | 100 to 470 | G12 | 10.0 | 11.7 |
| | | 135 °C 4000 h | | | | | | | | 11 to 15 | 150 to 560 | G16 | 10.0 | 15.7 |
| ZSU-A | EEHAZS--UB | 125 °C 4000 h | | ● | ● | | | -55 to 135 | 25 to 63 | 14 to 19 | 120 to 680 | G12 | 10.0 | 11.7 |
| | | 135 °C 4000 h | | | | | | | | 11 to 15 | 180 to 1000 | G16 | 10.0 | 15.7 |
| ZE-A | EEHAZE---B | 145 °C 2000 h | | | | ● | ● | -55 to 145 | 25 to 63 | 27 to 40 | 33 to 220 | F | 8.0 | 9.5 |
| | | 135 °C 4000 h | | | | | | | | 20 to 30 | 56 to 330 | G | 10.0 | 9.5 |
| ZF-A | EEHAZF---B | 150 °C 1000 h | | | | ● | ● | -55 to 150 | 25 to 63 | 27 to 40 | 33 to 150 | F | 8.0 | 9.5 |
| | | | | | | | | | | 20 to 30 | 56 to 270 | G | 10.0 | 9.5 |

Series flow chart

● Surface mount type

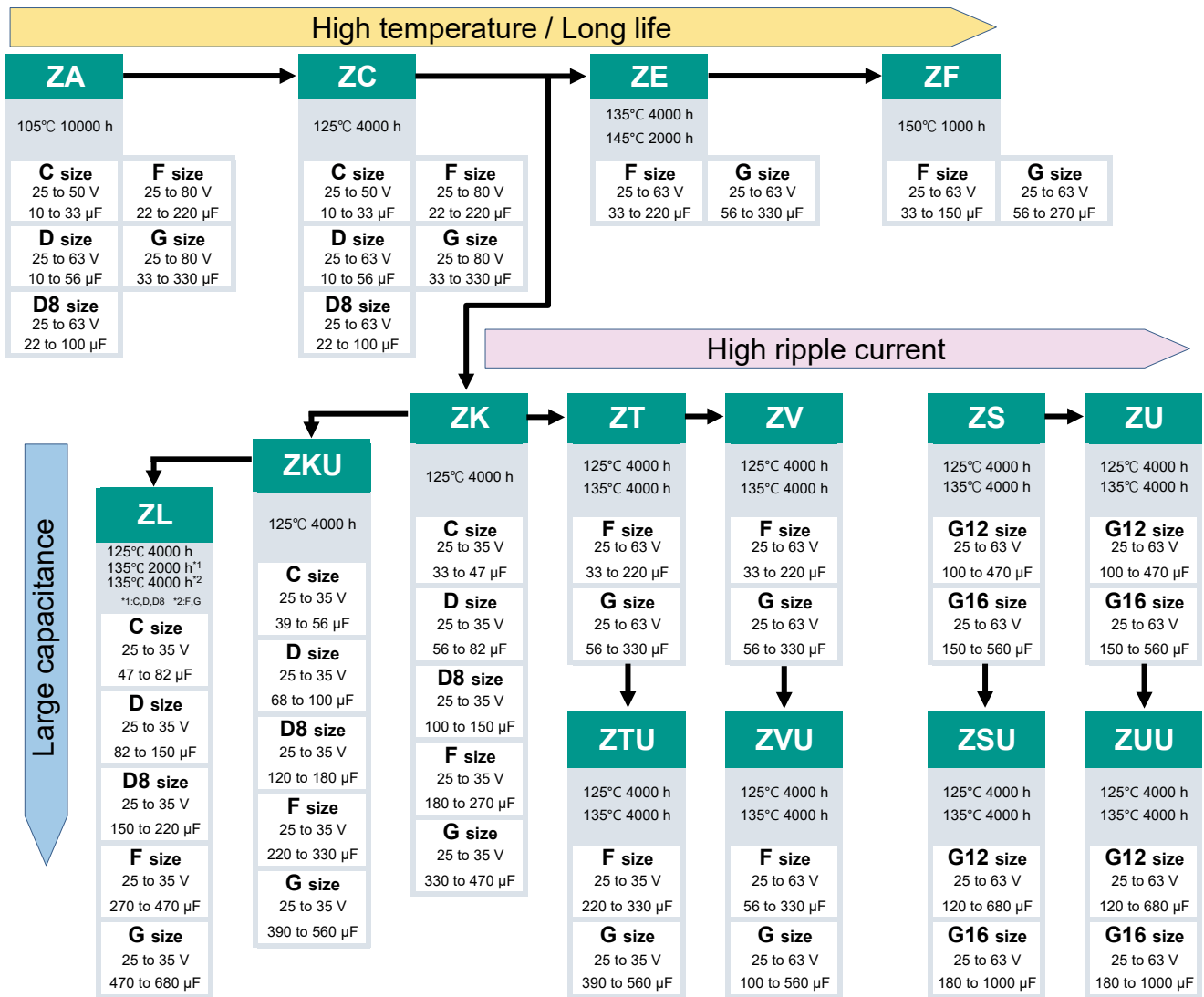

● Radial lead type

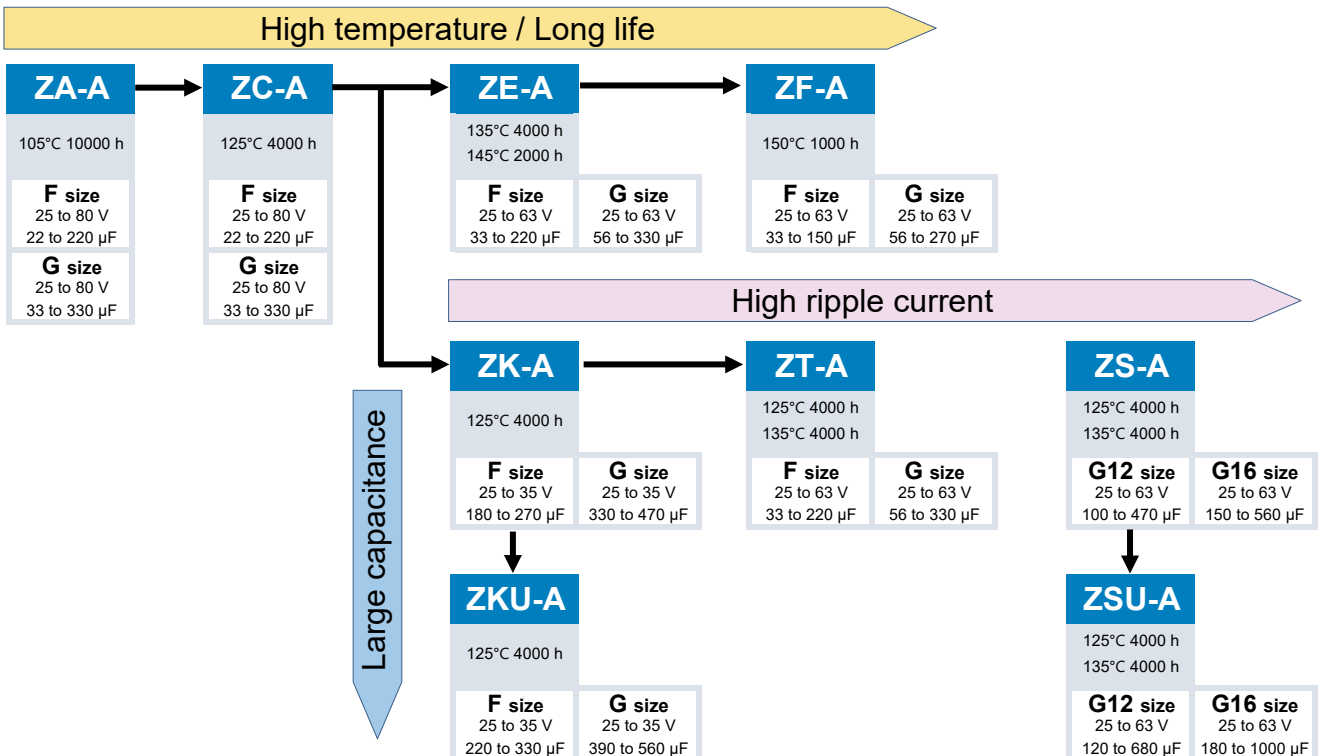

Voltage - Capacitance table (SMD type) (Vol. : 25 to 80 V / Cap. : 10 to 120 μF)

Series [Size]
(ESR mΩ)

| W | μF | 10 | 22 | 27 | 33 | 39 | 47 | 56 | 68 | 82 | 100 | 120 |
|----|----|-----------------|-----------------|----------------|-----------------|------------------|----------------|-----------------|-----------------|-----------------|------------------|-------------------|
| 25 | | | ZA [C] (80) | | ZA [C] (80) | | ZA [D] (50) | ZA [D] (50) | ZA [D8] (30) | ZK [D] (50) | ZA [D8] (30) | |
| | | | ZC [C] (80) | | ZC [C] (80) | | ZC [D] (50) | ZC [D] (50) | ZC [D8] (30) | ZL [C] (58) | ZC [D8] (30) | |
| | | | | | | | ZK [C] (80) | ZKU [C] (80) | ZK [D] (50) | | ZKU [D] (50) | |
| | | | | | | | | | | | | |
| | | | | | | | | | | | | |
| | | | | | | | | | | | | |
| | | | | | | | | | | | | |
| 35 | | ZA [C] (100) | ZA [C] (100) | ZA [D] (60) | ZA [D] (60) | ZKU [C] (100) | ZA [D] (60) | ZK [D] (60) | ZA [D8] (35) | ZL [D] (40) | ZA [F] (27) | ZKU [D8] (35) |
| | | ZC [C] (100) | ZC [C] (100) | | ZC [D] (60) | | ZC [D] (60) | | ZC [D8] (35) | | ZC [F] (27) | |
| | | | | | ZK [C] (100) | | ZL [C] (60) | | ZKU [D] (60) | | ZK [D8] (35) | |
| | | | | | | | | | | | ZF [F] (30) | |
| | | | | | | | | | | | | |
| | | | | | | | | | | | | |
| 50 | | ZA [C] (120) | ZA [D] (80) | | ZA [D8] (40) | | ZA [F] (30) | ZF [F] (35) | ZA [F] (30) | ZVU [F] (19) | ZA [G] (28) | ZC [G] (28) |
| | | ZC [C] (120) | ZC [D] (80) | | ZC [D8] (40) | | ZC [F] (30) | | ZC [F] (30) | | ZC [G] (28) | ZT [G] (23) |
| | | | | | | | | | ZT [F] (25) | | ZT [G] (23) | ZV [G] (15) |
| | | | | | | | | | ZE [F] (30) | | ZE [G] (28) | |
| | | | | | | | | | ZV [F] (19) | | ZF [G] (28) | |
| | | | | | | | | | | | ZV [G] (15) | |
| 63 | | ZA [D] (120) | ZA [D8] (80) | | ZA [F] (40) | | ZA [F] (40) | ZA [G] (30) | ZA [G] (30) | ZA [G] (30) | ZS [G12] (19) | ZSU [G12] (19) |
| | | ZC [D] (120) | ZC [D8] (80) | | ZC [F] (40) | | ZC [F] (40) | ZC [G] (30) | ZC [G] (30) | ZC [G] (30) | ZU [G12] (12) | ZUU [G12] (12) |
| | | | | | ZT [F] (32) | | ZT [F] (32) | ZT [G] (25) | ZT [G] (25) | ZT [G] (25) | ZVU [G] (17) | |
| | | | | | ZE [F] (40) | | ZV [F] (22) | ZE [G] (30) | ZV [G] (17) | ZE [G] (30) | | |
| | | | | | ZF [F] (40) | | | ZF [G] (30) | | ZV [G] (17) | | |
| | | | | | ZV [F] (22) | | | ZV [G] (17) | | | | |
| | | | | | | | | ZVU [F] (22) | | | | |
| 80 | | | ZA [F] (45) | | ZA [G] (36) | | ZA [G] (36) | | | | | |
| | | | ZC [F] (45) | | ZC [G] (36) | | ZC [G] (36) | | | | | |
| | | | | | | | | | | | | |

Size list ø x L (mm)

| | | | | | | | |
|---|---------|----|---------|---|----------|-----|-----------|
| C | 5.0x5.8 | D | 6.3x5.8 | F | 8.0x10.2 | G | 10.0x10.2 |
| | | D8 | 6.3x7.7 | | | G12 | 10.0x12.5 |
| | | | | | | G16 | 10.0x16.5 |

Voltage - Capacitance table (SMD type) (Vol. : 25 to 80 V / Cap. : 150 to 1000 µF)

Series [Size]
(ESR mΩ)

| V | µF | 150 | 180 | 220 | 270 | 330 | 390 | 470 | 560 | 680 | 1000 |
|----|----|------------------|-------------------|------------------|-------------------|------------------|-----------------|-------------------|------------------|-------------------|-------------------|
| 25 | | ZA [F] (27) | ZKU [D8] (30) | ZA [F] (27) | ZK [F] (27) | ZA [G] (20) | | ZK [G] (20) | ZKU [G] (20) | ZSU [G12] (14) | ZSU [G16] (11) |
| | | ZC [F] (27) | | ZC [F] (27) | ZF [G] (20) | ZC [G] (20) | | ZS [G12] (14) | ZS [G16] (11) | ZUU [G12] (10) | ZUU [G16] (8) |
| | | ZK [D8] (30) | | ZT [F] (22) | | ZKU [F] (27) | | ZU [G12] (10) | ZU [G16] (8) | ZL [G] (14) | |
| | | ZF [F] (27) | | ZE [F] (27) | | ZT [G] (16) | | ZL [F] (18) | ZTU [G] (16) | | |
| | | ZL [D] (38) | | ZV [F] (16) | | ZE [G] (20) | | | ZVU [G] (12) | | |
| | | | | ZL [D8] (24) | | ZTU [F] (22) | | | | | |
| | | | | | | ZV [G] (12) | | | | | |
| | | | | | | ZVU [F] (16) | | | | | |
| 35 | | ZA [F] (27) | ZK [F] (27) | ZA [G] (20) | ZA [G] (20) | ZK [G] (20) | ZKU [G] (20) | ZS [G16] (11) | | ZSU [G16] (11) | |
| | | ZC [F] (27) | | ZC [G] (20) | ZC [G] (20) | ZS [G12] (14) | ZTU [G] (16) | ZSU [G12] (14) | | ZUU [G16] (9) | |
| | | ZT [F] (22) | | ZKU [F] (27) | ZT [G] (16) | ZU [G12] (11) | ZVU [G] (12) | ZU [G16] (9) | | | |
| | | ZE [F] (27) | | ZTU [F] (22) | ZE [G] (20) | | | ZUU [G12] (11) | | | |
| | | ZF [G] (23) | | ZVU [F] (16) | ZV [G] (12) | | | ZL [G] (16) | | | |
| | | ZV [F] (16) | | | ZL [F] (20) | | | | | | |
| | | ZL [D8] (26) | | | | | | | | | |
| 50 | | ZS [G12] (17) | ZSU [G12] (17) | ZS [G16] (13) | ZSU [G16] (13) | | | | | | |
| | | ZU [G12] (12) | ZUU [G12] (12) | ZU [G16] (10) | ZUU [G16] (10) | | | | | | |
| | | ZVU [G] (15) | | | | | | | | | |
| 63 | | ZS [G16] (15) | ZSU [G16] (15) | | | | | | | | |
| | | ZU [G16] (10) | ZUU [G16] (10) | | | | | | | | |
| 80 | | | | | | | | | | | |
| | | | | | | | | | | | |

Size list ø x L (mm)

| | | | | | | | |
|---|---------|----|---------|---|----------|-----|-----------|
| C | 5.0x5.8 | D | 6.3x5.8 | F | 8.0x10.2 | G | 10.0x10.2 |
| | | D8 | 6.3x7.7 | | | G12 | 10.0x12.5 |
| | | | | | | G16 | 10.0x16.5 |

Voltage - Capacitance table (Radial lead type) (Vol. : 25 to 80 V / Cap. : 22 to 150 μ F)

Series [Size]
(ESR m Ω)

| V | μ F | 22 | 27 | 33 | 39 | 47 | 56 | 68 | 82 | 100 | 120 | 150 |
|----|---------|----------------|----------------|----------------|----|----------------|----------------|----------------|----------------|------------------|-------------------|------------------|
| 25 | | | | | | | | | | | | ZA [F] (27) |
| | | | | | | | | | | | | ZC [F] (27) |
| | | | | | | | | | | | | ZF [F] (27) |
| | | | | | | | | | | | | |
| | | | | | | | | | | | | |
| 35 | | | | | | | | | | ZA [F] (27) | | ZA [F] (27) |
| | | | | | | | | | | ZC [F] (27) | | ZC [F] (27) |
| | | | | | | | | | | ZF [F] (30) | | ZK [F] (22) |
| | | | | | | | | | | | | ZE [F] (27) |
| | | | | | | | | | | | | ZF [G] (23) |
| 50 | | | | | | ZA [F] (30) | ZF [F] (35) | ZA [F] (30) | | ZA [G] (28) | ZC [G] (28) | ZS [G12] (17) |
| | | | | | | ZC [F] (30) | | ZC [F] (30) | | ZC [G] (28) | ZT [G] (23) | |
| | | | | | | | | ZT [F] (25) | | ZT [G] (23) | | |
| | | | | | | | | ZE [F] (30) | | ZE [G] (28) | | |
| | | | | | | | | | | ZF [G] (28) | | |
| 63 | | | ZA [F] (40) | | | ZA [F] (40) | ZA [G] (30) | ZA [G] (30) | ZA [G] (30) | ZS [G12] (19) | ZSU [G12] (19) | ZS [G16] (15) |
| | | | ZC [F] (40) | | | ZC [F] (40) | ZC [G] (30) | ZC [G] (30) | ZC [G] (30) | | | |
| | | | ZT [F] (32) | | | ZT [F] (32) | ZT [G] (25) | ZT [G] (25) | ZT [G] (25) | | | |
| | | | ZE [F] (40) | | | | ZE [G] (30) | | ZE [G] (30) | | | |
| | | | ZF [F] (40) | | | | ZF [G] (30) | | | | | |
| 80 | | ZA [F] (45) | | ZA [G] (36) | | ZA [G] (36) | | | | | | |
| | | ZC [F] (45) | | ZC [G] (36) | | ZC [G] (36) | | | | | | |

Size list ϕ x L (mm)

| | | | | | | | |
|---|-----------|---|------------|-----|-------------|-----|-------------|
| F | 8.0 x 9.5 | G | 10.0 x 9.5 | G12 | 10.0 x 11.7 | G16 | 10.0 x 15.7 |
|---|-----------|---|------------|-----|-------------|-----|-------------|

Voltage - Capacitance table (Radial lead type) (Vol. : 25 to 80 V / Cap. : 180 to 1000 μ F)

Series [Size]
(ESR m Ω)

| V | μ F | 180 | 220 | 270 | 330 | 390 | 470 | 560 | 680 | 1000 |
|----|---------|-------------------|------------------|-------------------|------------------|-----------------|-------------------|------------------|-------------------|-------------------|
| 25 | | | ZA [F] (27) | ZK [F] (27) | ZA [G] (20) | | ZK [G] (20) | ZKU [G] (20) | ZSU [G12] (14) | ZSU [G16] (11) |
| | | | ZC [F] (27) | ZF [G] (20) | ZC [G] (20) | | ZS [G12] (14) | ZS [G16] (11) | | |
| | | | ZT [F] (22) | | ZKU [F] (27) | | | | | |
| | | | ZE [F] (27) | | ZT [G] (16) | | | | | |
| | | | | | ZE [G] (20) | | | | | |
| | | | | | | | | | | |
| 35 | | ZK [F] (27) | ZA [G] (20) | ZA [G] (20) | ZK [G] (20) | ZKU [G] (20) | ZS [G16] (11) | | ZSU [G16] (11) | |
| | | | ZC [G] (20) | ZC [G] (20) | ZS [G12] (14) | | ZSU [G12] (14) | | | |
| | | | ZKU [F] (27) | ZT [G] (16) | | | | | | |
| | | | | ZE [G] (20) | | | | | | |
| | | | | | | | | | | |
| 50 | | ZSU [G12] (17) | ZS [G16] (13) | ZSU [G16] (13) | | | | | | |
| | | | | | | | | | | |
| | | | | | | | | | | |
| | | | | | | | | | | |
| | | | | | | | | | | |
| 63 | | ZSU [G16] (15) | | | | | | | | |
| | | | | | | | | | | |
| | | | | | | | | | | |
| | | | | | | | | | | |
| 80 | | | | | | | | | | |
| | | | | | | | | | | |

Size list ϕ x L (mm)

| | | | | | | | |
|---|-----------|---|------------|-----|-------------|-----|-------------|
| F | 8.0 x 9.5 | G | 10.0 x 9.5 | G12 | 10.0 x 11.7 | G16 | 10.0 x 15.7 |
|---|-----------|---|------------|-----|-------------|-----|-------------|

Explanation of part numbers

◇ Part number system

• Surface mount type

| | | | | | | |
|---|--|---|---|--|---|---|
| EEH Product classification 3 figures | ZC Series 2 figures | 1E Voltage code 1 to 2 figures | 101 Capacitance code 3 figures | X Size code 0 to 1 figure | * Special code 0 to 1 figure | P Taping/ Special code 1 figure |
| | Series Code | Rated voltage (V) Code | Cap. (μF) Code | øD x L Code | Dia øD Code | Tape width (mm) Code |
| | ZA ZA ZC ZC ZK ZK ZKU ZK ZL ZL ZT ZT ZTU ZT ZV ZV ZVU ZV ZS ZS ZSU ZS ZU ZU ZUU ZU ZE ZE ZF ZF | 25 1E 35 1V 50 1H 63 1J 80 1K | 10 100 22 220 27 270 33 330 39 390 47 470 56 560 68 680 82 820 100 101 120 121 150 151 180 181 220 221 270 271 330 331 390 391 470 471 560 561 680 681 1000 102 | 6.3 x 7.7 (D8) X | Minia-turization product U | 12 R 16, 24 P |
| | | | | * Only D8 is marked with X | | Replace for the following configuration |
| | | | | | | Configuration Code Vibration proof V |

* If the total figures number of the part number exceeds 12 figures, "1" is omitted.
e.g.) 1E → E

• Radial lead type

| | | | | | |
|--|---|--|---|---|-------------------------------------|
| EEHA Product classification 4 figures | ZC Series 2 figures | 1E Voltage code 1 to 2 figure | 151 Capacitance code 3 figures | * Special code 0 to 1 figure | B Taping code 1 figure |
| | Series Code | Rated voltage (V) Code | Cap. (μF) Code | Dia øD Code | Lead space (mm) Code |
| | ZA ZA ZC ZC ZK ZK ZKU ZK ZT ZT ZS ZS ZSU ZS ZE ZE ZF ZF | 25 1E 35 1V 50 1H 63 1J 80 1K | 22 220 33 330 47 470 56 560 68 680 82 820 100 101 120 121 150 151 180 181 220 221 270 271 330 331 390 391 470 471 560 561 680 681 1000 102 | Minia-turization product U | 3.5, 5.0 B |

* If the total figures number of the part number exceeds 12 figures, "1" is omitted.
e.g.) 1E → E

Recommended reflow soldering

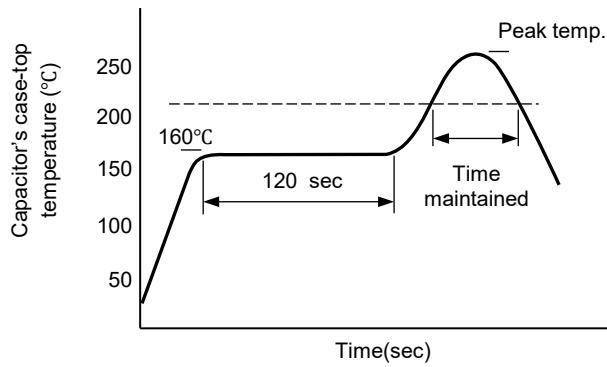

| Size code | C, D, D8 | F, G, G12, G16 | |
|--------------------------|--------------------|----------------|--------------|
| Peak temp. | 260°C (255°C) | 245°C | 260°C |
| Time in peak temperature | ≥ 250°C 5 s (10 s) | ≥ 240°C 10 s | ≥ 250°C 5 s |
| Time maintained | ≥ 230°C 30 s | ≥ 230°C 30 s | ≥ 230°C 30 s |
| | ≥ 217°C 40 s | ≥ 217°C 40 s | ≥ 217°C 40 s |
| | ≥ 200°C 70 s | ≥ 200°C 70 s | ≥ 200°C 70 s |
| Reflow cycles | 2 times | 2 times | 1 time |

* For reflow, use a thermal condition system such as infrared and radiation (IR) or hot blas.

* Reflow temperature is measured on capacitor's case top.

Specifications for radial lead type

- Flow soldering condition
- < RoHS compliant >

| Soldering condition | Temperature | Time | Flow number |
|---------------------|---------------------|-----------------------|-------------|
| | 260°C + 5°C or less | 10 sec +1 sec or less | 1 time |

Dimensions (Vibration-proof products)

The size and shape are different from standard products.

< Size code : D, D8 >

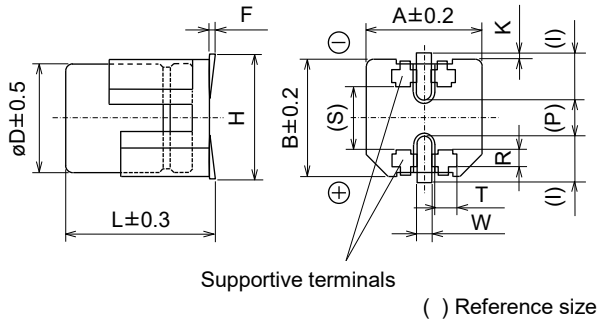

Unit : mm

| Size code | øD | L | A, B | H max. | F | I | W |
|-----------|-----|-----|------|--------|------------|-----|----------|
| D | 6.3 | 6.1 | 6.6 | 7.8 | 0 to +0.15 | 2.4 | 0.65±0.1 |
| D8 | 6.3 | 8.0 | 6.6 | 7.8 | 0 to +0.15 | 2.4 | 0.65±0.1 |

| Size code | P | K | R | S | T |
|-----------|-----|--|---------|-----|----------|
| D | 2.2 | 0.35 ^{+0.15} _{-0.20} | 1.1±0.2 | 3.3 | 1.05±0.2 |
| D8 | 2.2 | 0.35 ^{+0.15} _{-0.20} | 1.1±0.2 | 3.3 | 1.05±0.2 |

< Size code : F, G, G12, G16 >

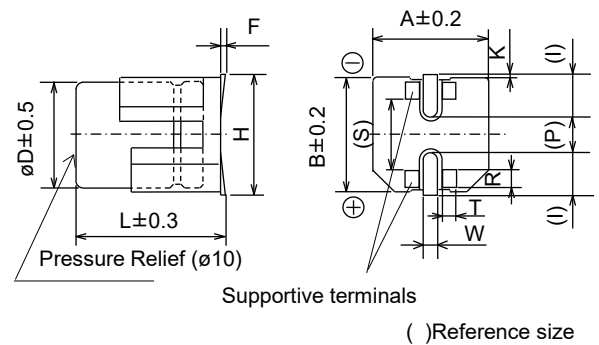

Unit : mm

| Size code | øD | L | A, B | H max. | F | I | W |
|-----------|------|------|------|--------------------|------------|-----|---------|
| F | 8.0 | 10.5 | 8.3 | 10.0 | 0 to +0.15 | 3.4 | 1.2±0.2 |
| G | 10.0 | 10.5 | 10.3 | 12.0 | 0 to +0.15 | 3.5 | 1.2±0.2 |
| G12 | 10.0 | 12.8 | 10.3 | 11.0 ^{*1} | 0 to +0.15 | 3.2 | 1.2±0.2 |
| G16 | 10.0 | 16.8 | 10.3 | 11.0 ^{*1} | 0 to +0.15 | 3.2 | 1.2±0.2 |

^{*1}:±0.2

| Size code | P | K | R | S | T |
|-----------|-----|----------|----------|-----|---------|
| F | 3.1 | 0.70±0.2 | 0.70±0.2 | 5.3 | 1.3±0.2 |
| G | 4.6 | 0.70±0.2 | 0.70±0.2 | 6.9 | 1.3±0.2 |
| G12 | 4.6 | — | 0.70±0.2 | 6.9 | 1.3±0.2 |
| G16 | 4.6 | — | 0.70±0.2 | 6.9 | 1.3±0.2 |

Mounting specification

Land / Pad pattern

The circuit board land/pad pattern size for chip capacitors is specified in the following table.
The land pitch influences installation strength.

● Standard products

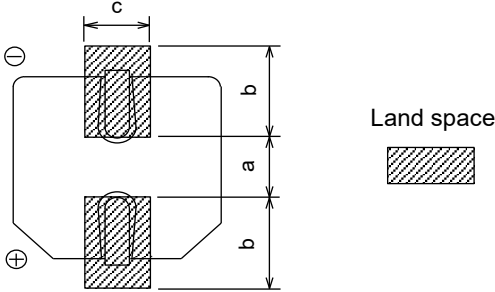

Unit : mm

| Size code | a | b | c |
|------------------------------|-----|-----|-----|
| C : $\phi 5 \times L5.8$ | 1.5 | 2.8 | 1.6 |
| D : $\phi 6.3 \times L5.8$ | 1.8 | 3.2 | 1.6 |
| D8 : $\phi 6.3 \times L7.7$ | 1.8 | 3.2 | 1.6 |
| F : $\phi 8 \times L10.2$ | 3.1 | 4.0 | 2.0 |
| G : $\phi 10 \times L10.2$ | 4.6 | 4.1 | 2.0 |
| G12 : $\phi 10 \times L12.5$ | 4.6 | 4.1 | 2.0 |
| G16 : $\phi 10 \times L16.5$ | 4.6 | 4.1 | 2.0 |

Larger dimension of "a" may prevent back fillet from being formed adequately to obtain required solder strength.

* Take mounting conditions, solderability and fitting strength into consideration when selecting parts for your design.

● Vibration-proof products

< Size code : D, D8 >

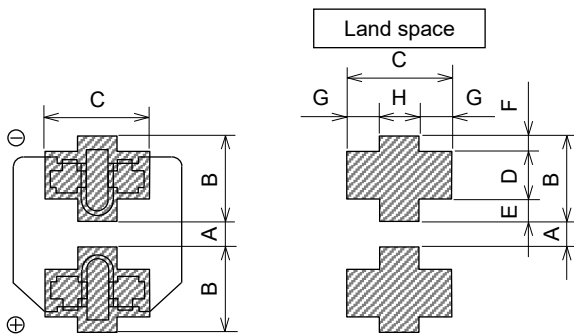

Unit : mm

| Size code | A | B | C | D |
|-----------------------------|-----|-----|-----|-----|
| D : $\phi 6.3 \times L6.1$ | 1.2 | 3.6 | 3.2 | 2.0 |
| D8 : $\phi 6.3 \times L8.0$ | 1.2 | 3.6 | 3.2 | 2.0 |

| Size code | E | F | G | H |
|-----------------------------|------|------|-----|-----|
| D : $\phi 6.3 \times L6.1$ | 0.95 | 0.65 | 1.0 | 1.2 |
| D8 : $\phi 6.3 \times L8.0$ | 0.95 | 0.65 | 1.0 | 1.2 |

Larger dimension of "A" may prevent back fillet from being formed adequately to obtain required solder strength.

< Size code : F, G, G12, G16 >

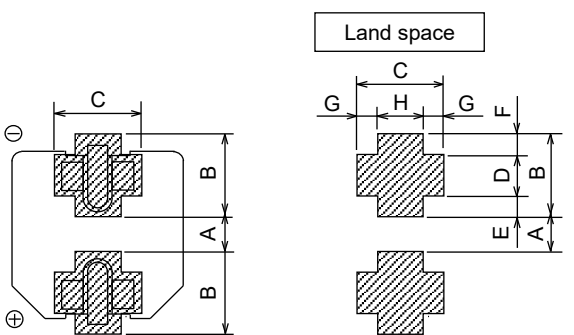

Unit : mm

| Size code | A | B | C | D |
|------------------------------|-----|-----|-----|-----|
| F : $\phi 8 \times L10.5$ | 2.7 | 4.0 | 4.7 | 1.3 |
| G : $\phi 10 \times L10.5$ | 3.9 | 4.4 | 4.7 | 1.3 |
| G12 : $\phi 10 \times L12.8$ | 3.9 | 4.4 | 4.7 | 1.3 |
| G16 : $\phi 10 \times L16.8$ | 3.9 | 4.4 | 4.7 | 1.3 |

| Size code | E | F | G | H |
|------------------------------|-----|-----|-----|-----|
| F : $\phi 8 \times L10.5$ | 1.0 | 1.7 | 1.1 | 2.5 |
| G : $\phi 10 \times L10.5$ | 1.2 | 1.9 | 1.1 | 2.5 |
| G12 : $\phi 10 \times L12.8$ | 1.2 | 1.9 | 1.1 | 2.5 |
| G16 : $\phi 10 \times L16.8$ | 1.2 | 1.9 | 1.1 | 2.5 |

Larger dimension of "A" may prevent back fillet from being formed adequately to obtain required solder strength.

* Take mounting conditions, solderability and fitting strength into consideration when selecting parts for your design.

* The vibration-proof capacitors of size $\phi 6.3$ has support terminals extending from the bottom side to the lead edge. Then, make sure to find appropriate soldering conditions to form fillet on the support terminals if required for appearance inspection.

Packaging specifications

Specifications for surface mount type

● Reel dimensions (not to scale)

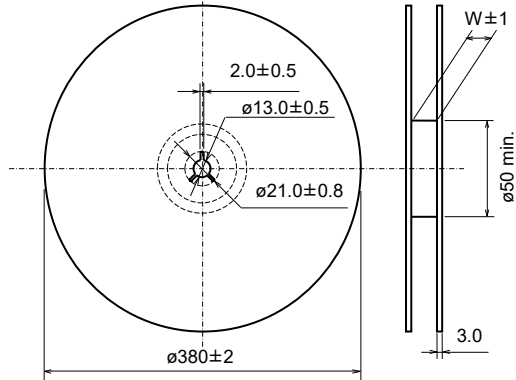

Unit : mm

| Size code | W |
|----------------|------|
| C | 14.0 |
| D, D8 | 18.0 |
| F, G, G12, G16 | 26.0 |

● Dimensions of outer carton box

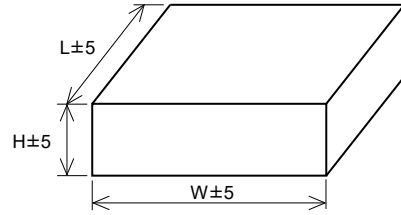

Unit : mm

| Size code | H | W, L |
|----------------|-----|------|
| C | 180 | 395 |
| D, D8 | 220 | 395 |
| F, G, G12, G16 | 180 | 395 |

● Min.packing quantity

| Size code | Min.packing quantity (pcs.) |
|-----------|-----------------------------|
| C, D | 1000 |
| D8 | 900 |
| F, G | 500 |
| G12 | 400 |
| G16 | 250 |

● Taping dimensions

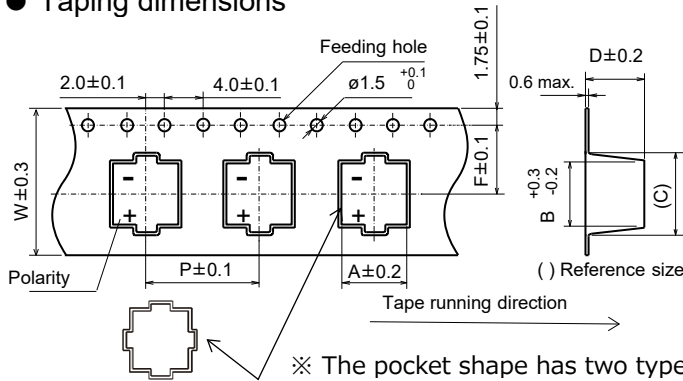

Unit : mm

| Size code | A | B | C | D | P | F | W |
|-----------|------|------|------|------|------|------|------|
| C | 5.7 | 5.7 | 8.0 | 6.4 | 12.0 | 5.5 | 12.0 |
| D | 7.0 | 7.0 | 9.0 | 6.4 | 12.0 | 7.5 | 16.0 |
| D8 | 7.0 | 7.0 | 9.0 | 8.4 | 12.0 | 7.5 | 16.0 |
| F | 8.7 | 8.7 | 12.5 | 11.0 | 16.0 | 11.5 | 24.0 |
| G | 10.7 | 10.7 | 14.5 | 11.0 | 16.0 | 11.5 | 24.0 |
| G12 | 10.7 | 10.7 | 14.5 | 13.7 | 16.0 | 11.5 | 24.0 |
| G16 | 10.7 | 10.7 | 14.5 | 17.5 | 20.0 | 11.5 | 24.0 |

Radial lead type

● Taping dimensions

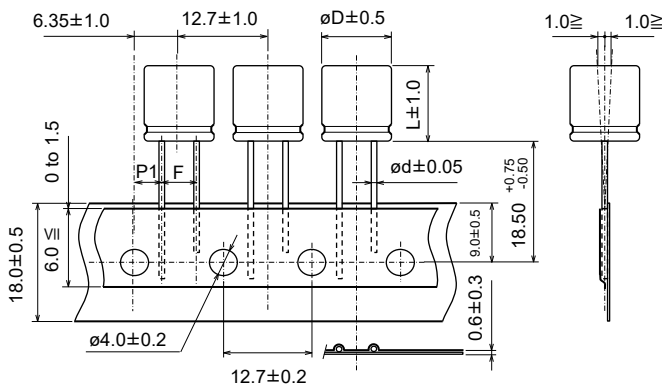

Unit : mm

| Size code | øD | L | ød | F | P1 |
|-----------|------|------|-----|--------------|-----------|
| F | 8.0 | 9.5 | 0.6 | 3.5±0.5 | 4.60±0.50 |
| G | 10.0 | 9.5 | 0.6 | 5.0+0.8/-0.2 | 3.85±0.50 |
| G12 | 10.0 | 11.7 | 0.8 | 5.0+0.8/-0.2 | 3.85±0.50 |
| G16 | 10.0 | 15.7 | 0.8 | 5.0+0.8/-0.2 | 3.85±0.50 |

● Dimensions of outer carton box / Packaging method

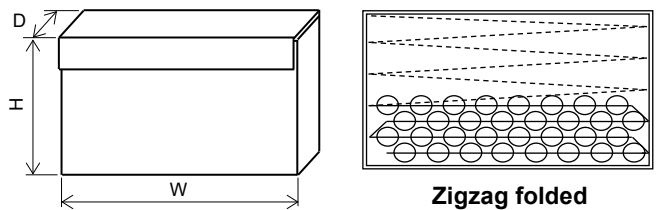

Unit : mm

| Size code | W | H | D |
|-----------|----------|----------|---------|
| F | 340 max. | 230 max. | 55 max. |
| G | 340 max. | 170 max. | 55 max. |
| G12 | 340 max. | 170 max. | 55 max. |
| G16 | 340 max. | 170 max. | 55 max. |

● Min.packing quantity

| Size code | Min.packing quantity (pcs.) |
|-----------|-----------------------------|
| F | 1000 |
| G | 500 |
| G12 | 500 |
| G16 | 500 |

Conductive Polymer Hybrid Aluminum Electrolytic Capacitors
Surface Mount Type

ZA series

High temperature lead-free reflow

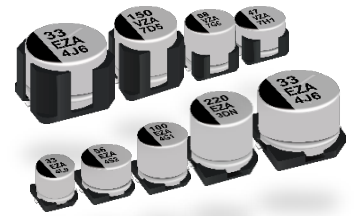

Features

- Endurance : 10000 h at 105 °C
- Low ESR and high ripple current (over 70% lower ESR and 100% higher ripple current than V-FP)
- High voltage (to 80 V)
- Characteristics dependencies in frequency and low temperature are as small as polymer type
- Vibration-proof product is available upon request (ø6.3, ø8, ø10)
- AEC-Q200 compliant
- RoHS compliant

Specifications

| Size code | C | D | D8 | F | G |
|---|--|----------------------------------|-----------------|-----------------|-----------------|
| Category temp. range | -55 °C to +105 °C | | | | |
| Rated voltage range | 25 V to 50 V | 25 V to 63 V | | 25 V to 80 V | |
| Nominal capacitance range | 10 µF to 33 µF | 10 µF to 56 µF | 22 µF to 100 µF | 22 µF to 220 µF | 33 µF to 330 µF |
| Capacitance tolerance | ±20 % (120 Hz / +20 °C) | | | | |
| Leakage current | I ≤ 0.01 CV (µA), 2 minutes after reaching rated voltage, 20 °C *CV = (Capacitance in µF) x (Rated voltage in V) | | | | |
| Dissipation factor (tan δ) | Please see the attached characteristics list | | | | |
| Surge voltage (V) | Rated voltage × 1.25 (15 °C to 35 °C) | | | | |
| Endurance | +105 °C ± 2 °C, 10000 h, apply the rated ripple current without exceeding the rated voltage. | | | | |
| | Capacitance change | Within ±30% of the initial value | | | |
| | Dissipation factor (tan δ) | ≤ 200 % of the initial limit | | | |
| | ESR | ≤ 200 % of the initial limit | | | |
| | Leakage current | Within the initial limit | | | |
| ESR after endurance (Ω / 100 kHz)(-40 °C) | Size code | | | | |
| | C | D | D8 | F | G |
| | 2.0 | 1.4 | 0.8 | 0.4 | 0.3 |
| Shelf life | After storage for 1000 hours at +105 °C ± 2 °C with no voltage applied and then being stabilized at +20 °C, capacitors shall meet the limits specified in endurance. (Capacitors are left at room temperature and humidity for 2 hours after the test. Then, apply the rated voltage for 30min with a series protection resistance of 1000 Ω ± 10 Ω. Measure electrical characteristics after discharging the capacitor.) | | | | |
| | +85 °C ± 2 °C, 85 % to 90 %RH, 2000 h, rated voltage applied | | | | |
| Damp heat (Load) | +85 °C ± 2 °C, 85 % to 90 %RH, 2000 h, rated voltage applied | | | | |
| | Capacitance change | Within ±30% of the initial value | | | |
| | Dissipation factor (tan δ) | ≤ 200 % of the initial limit | | | |
| | ESR | ≤ 200 % of the initial limit | | | |
| | Leakage current | Within the initial limit | | | |
| Resistance to soldering heat | After reflow soldering and then being stabilized at +20 °C, capacitors shall meet the following limits. | | | | |
| | Capacitance change | Within ±10% of the initial value | | | |
| | Dissipation factor (tan δ) | Within the initial limit | | | |
| | Leakage current | Within the initial limit | | | |

Marking

Example : 25 V 33 µF
Marking color : BLACK

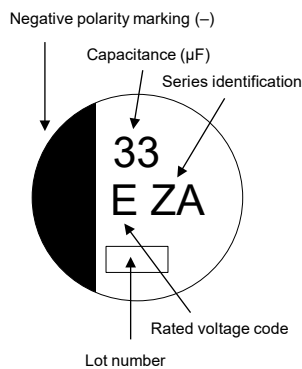

| R. voltage code | Unit : V |
|-----------------|----------|
| E | 25 |
| V | 35 |
| H | 50 |
| J | 63 |
| K | 80 |

Dimensions (not to scale)

[Standard]

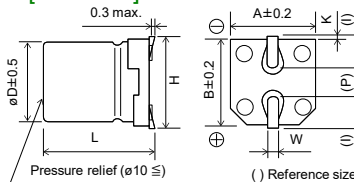

| Size code | øD | L | A, B | H _{max.} | I | W | P | K |
|-----------|------|----------|------|-------------------|-----|----------|-----|--|
| C | 5.0 | 5.8±0.3 | 5.3 | 6.5 | 2.2 | 0.65±0.1 | 1.5 | 0.35 ^{+0.15} _{-0.20} |
| D | 6.3 | 5.8±0.3 | 6.6 | 7.8 | 2.6 | 0.65±0.1 | 1.8 | 0.35 ^{+0.15} _{-0.20} |
| D8 | 6.3 | 7.7±0.3 | 6.6 | 7.8 | 2.6 | 0.65±0.1 | 1.8 | 0.35 ^{+0.15} _{-0.20} |
| F | 8.0 | 10.2±0.3 | 8.3 | 10 | 3.4 | 0.90±0.2 | 3.1 | 0.70±0.2 |
| G | 10.0 | 10.2±0.3 | 10.3 | 12.0 | 3.5 | 0.90±0.2 | 4.6 | 0.70±0.2 |

[Vibration-proof product]

< Size code : D, D8 >

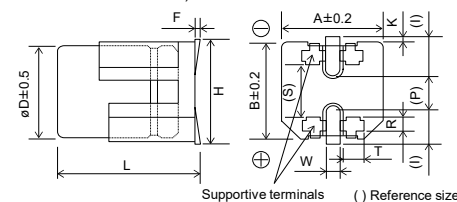

| Size code | øD | L | A, B | H _{max.} | F | I | W | P | K | R | S | T |
|-----------|------|----------|------|-------------------|------------|-----|----------|-----|--|----------|-----|----------|
| D | 6.3 | 6.1±0.3 | 6.6 | 7.8 | 0 to +0.15 | 2.4 | 0.65±0.1 | 2.2 | 0.35 ^{+0.15} _{-0.20} | 1.1±0.2 | 3.3 | 1.05±0.2 |
| D8 | 6.3 | 8.0±0.3 | 6.6 | 7.8 | 0 to +0.15 | 2.4 | 0.65±0.1 | 2.2 | 0.35 ^{+0.15} _{-0.20} | 1.1±0.2 | 3.3 | 1.05±0.2 |
| F | 8.0 | 10.5±0.3 | 8.3 | 10.0 | 0 to +0.15 | 3.4 | 1.2±0.2 | 3.1 | 0.70±0.2 | 0.70±0.2 | 5.3 | 1.3±0.2 |
| G | 10.0 | 10.5±0.3 | 10.3 | 12.0 | 0 to +0.15 | 3.5 | 1.2±0.2 | 4.6 | 0.70±0.2 | 0.70±0.2 | 6.9 | 1.3±0.2 |

Explanation of part numbers

◆ **Part number system**

e.g.: EEHZA1E220R

| | | | | | | | | | | | | |
|------------------------|-----------|------|-------------------|--------|------------------|------|------------------|------|-----------------------|------|-----------------|------|
| EEH | ZA | | 1E | | 220 | | | | X | | R | |
| Product classification | Series | Code | Rated voltage (V) | Code * | Capacitance (μF) | Code | Capacitance (μF) | Code | D8 size** øDxL(mm) | Code | Tape width (mm) | Code |
| | ZA | ZA | 25 | 1E | 10 | 100 | 68 | 680 | 6.3 x 7.7 | X | 12 | R |
| | | | 35 | 1V | 22 | 220 | 100 | 101 | | | 16, 24 | P |
| | | | 50 | 1H | 27 | 270 | 150 | 151 | | | | |
| | | | 63 | 1J | 33 | 330 | 220 | 221 | | | | |
| | | | 80 | 1K | 39 | 390 | 270 | 271 | | | | |
| | | | | | 47 | 470 | 330 | 331 | | | | |
| | | | | | 56 | 560 | | | | | | |

*: If the total figures number of the part number exceeds 12 figures, "1" is omitted.

**: Only D8 is marked with X

| | |
|---|------|
| Replace for the following configuration | |
| Configuration | Code |
| Vibration proof | V |

Characteristics list

Endurance : 105 °C 10000 h

| Rated voltage (V) | Capacitance (±20 %) (μF) | Case size (mm) | | | Size code | Specification | | | Part number | | Min. packaging q'ty (pcs) |
|-------------------|--------------------------|----------------|----------|-----------------|-----------|---------------------------|------------|---------|------------------|-------------------------|---------------------------|
| | | øD | L | | | Ripple current*1 (mA rms) | ESR*2 (mΩ) | tan δ*3 | Standard product | Vibration-proof product | Taping |
| | | | Standard | Vibration-proof | | | | | | | |
| 25 | 22 | 5.0 | 5.8 | - | C | 900 | 80 | 0.14 | EEHZA1E220R | - | 1000 |
| | 33 | 5.0 | 5.8 | - | C | 900 | 80 | 0.14 | EEHZA1E330R | - | 1000 |
| | 47 | 6.3 | 5.8 | 6.1 | D | 1300 | 50 | 0.14 | EEHZA1E470P | EEHZA1E470V | 1000 |
| | 56 | 6.3 | 5.8 | 6.1 | D | 1300 | 50 | 0.14 | EEHZA1E560P | EEHZA1E560V | 1000 |
| | 68 | 6.3 | 7.7 | 8.0 | D8 | 2000 | 30 | 0.14 | EEHZA1E680XP | EEHZA1E680XV | 900 |
| | 100 | 6.3 | 7.7 | 8.0 | D8 | 2000 | 30 | 0.14 | EEHZA1E101XP | EEHZA1E101XV | 900 |
| | 150 | 8.0 | 10.2 | 10.5 | F | 2300 | 27 | 0.14 | EEHZA1E151P | EEHZA1E151V | 500 |
| | 220 | 8.0 | 10.2 | 10.5 | F | 2300 | 27 | 0.14 | EEHZA1E221P | EEHZA1E221V | 500 |
| 35 | 330 | 10.0 | 10.2 | 10.5 | G | 2500 | 20 | 0.14 | EEHZA1E331P | EEHZA1E331V | 500 |
| | 10 | 5.0 | 5.8 | - | C | 900 | 100 | 0.12 | EEHZA1V100R | - | 1000 |
| | 22 | 5.0 | 5.8 | - | C | 900 | 100 | 0.12 | EEHZA1V220R | - | 1000 |
| | 27 | 6.3 | 5.8 | 6.1 | D | 1300 | 60 | 0.12 | EEHZA1V270P | EEHZA1V270V | 1000 |
| | 33 | 6.3 | 5.8 | 6.1 | D | 1300 | 60 | 0.12 | EEHZA1V330P | EEHZA1V330V | 1000 |
| | 47 | 6.3 | 5.8 | 6.1 | D | 1300 | 60 | 0.12 | EEHZA1V470P | EEHZA1V470V | 1000 |
| | 68 | 6.3 | 7.7 | 8.0 | D8 | 2000 | 35 | 0.12 | EEHZA1V680XP | EEHZA1V680XV | 900 |
| | 100 | 8.0 | 10.2 | 10.5 | F | 2300 | 27 | 0.12 | EEHZA1V101P | EEHZA1V101V | 500 |
| 50 | 150 | 8.0 | 10.2 | 10.5 | F | 2300 | 27 | 0.12 | EEHZA1V151P | EEHZA1V151V | 500 |
| | 220 | 10.0 | 10.2 | 10.5 | G | 2500 | 20 | 0.12 | EEHZA1V221P | EEHZA1V221V | 500 |
| | 270 | 10.0 | 10.2 | 10.5 | G | 2500 | 20 | 0.12 | EEHZA1V271P | EEHZA1V271V | 500 |
| | 10 | 5.0 | 5.8 | - | C | 750 | 120 | 0.10 | EEHZA1H100R | - | 1000 |
| | 22 | 6.3 | 5.8 | 6.1 | D | 1100 | 80 | 0.10 | EEHZA1H220P | EEHZA1H220V | 1000 |
| | 33 | 6.3 | 7.7 | 8.0 | D8 | 1600 | 40 | 0.10 | EEHZA1H330XP | EEHZA1H330XV | 900 |
| | 47 | 8.0 | 10.2 | 10.5 | F | 1800 | 30 | 0.10 | EEHZA1H470P | EEHZA1H470V | 500 |
| | 68 | 8.0 | 10.2 | 10.5 | F | 1800 | 30 | 0.10 | EEHZA1H680P | EEHZA1H680V | 500 |
| 63 | 100 | 10.0 | 10.2 | 10.5 | G | 2000 | 28 | 0.10 | EEHZA1H101P | EEHZA1H101V | 500 |
| | 10 | 6.3 | 5.8 | 6.1 | D | 1000 | 120 | 0.08 | EEHZA1J100P | EEHZA1J100V | 1000 |
| | 22 | 6.3 | 7.7 | 8.0 | D8 | 1500 | 80 | 0.08 | EEHZA1J220XP | EEHZA1J220XV | 900 |
| | 33 | 8.0 | 10.2 | 10.5 | F | 1700 | 40 | 0.08 | EEHZA1J330P | EEHZA1J330V | 500 |
| | 47 | 8.0 | 10.2 | 10.5 | F | 1700 | 40 | 0.08 | EEHZA1J470P | EEHZA1J470V | 500 |
| | 56 | 10.0 | 10.2 | 10.5 | G | 1800 | 30 | 0.08 | EEHZA1J560P | EEHZA1J560V | 500 |
| | 68 | 10.0 | 10.2 | 10.5 | G | 1800 | 30 | 0.08 | EEHZA1J680P | EEHZA1J680V | 500 |
| | 82 | 10.0 | 10.2 | 10.5 | G | 1800 | 30 | 0.08 | EEHZA1J820P | EEHZA1J820V | 500 |
| 80 | 22 | 8.0 | 10.2 | 10.5 | F | 1550 | 45 | 0.08 | EEHZA1K220P | EEHZA1K220V | 500 |
| | 33 | 10.0 | 10.2 | 10.5 | G | 1700 | 36 | 0.08 | EEHZA1K330P | EEHZA1K330V | 500 |
| | 47 | 10.0 | 10.2 | 10.5 | G | 1700 | 36 | 0.08 | EEHZA1K470P | EEHZA1K470V | 500 |

*1: Ripple current (100 kHz / +105 °C)

*2: ESR (100 kHz / +20 °C)

*3: tan δ (120 Hz / +20 °C)

◆ Please refer to the page of "Reflow profile" and "The taping dimensions".

◆ The dimensions of the vibration-proof products, please refer to the page of the mounting specification.

Frequency correction factor for ripple current

| Rated capacitance (C) | Frequency (f) | 100 Hz ≤ f < 200 Hz | 200 Hz ≤ f < 300 Hz | 300 Hz ≤ f < 500 Hz | 500 Hz ≤ f < 1 kHz |
|-----------------------|-------------------|---------------------|----------------------|-----------------------|---------------------|
| C < 47 μF | Correction factor | 0.10 | 0.10 | 0.15 | 0.20 |
| 47 μF ≤ C < 150 μF | | 0.15 | 0.20 | 0.25 | 0.30 |
| 150 μF ≤ C | | 0.15 | 0.25 | 0.25 | 0.30 |
| Rated capacitance (C) | Frequency (f) | 1 kHz ≤ f < 2 kHz | 2 kHz ≤ f < 3 kHz | 3 kHz ≤ f < 5 kHz | 5 kHz ≤ f < 10 kHz |
| C < 47 μF | Correction factor | 0.30 | 0.40 | 0.45 | 0.50 |
| 47 μF ≤ C < 150 μF | | 0.40 | 0.45 | 0.55 | 0.60 |
| 150 μF ≤ C | | 0.45 | 0.50 | 0.60 | 0.65 |
| Rated capacitance (C) | Frequency (f) | 10 kHz ≤ f < 15 kHz | 15 kHz ≤ f < 20 kHz | 20 kHz ≤ f < 30 kHz | 30 kHz ≤ f < 40 kHz |
| C < 47 μF | Correction factor | 0.60 | 0.65 | 0.70 | 0.75 |
| 47 μF ≤ C < 150 μF | | 0.70 | 0.75 | 0.80 | 0.80 |
| 150 μF ≤ C | | 0.75 | 0.80 | 0.85 | 0.85 |
| Rated capacitance (C) | Frequency (f) | 40 kHz ≤ f < 50 kHz | 50 kHz ≤ f < 100 kHz | 100 kHz ≤ f < 500 kHz | 500 kHz ≤ f |
| C < 47 μF | Correction factor | 0.80 | 0.85 | 1.00 | 1.05 |
| 47 μF ≤ C < 150 μF | | 0.85 | 0.90 | 1.00 | 1.00 |
| 150 μF ≤ C | | 0.85 | 0.90 | 1.00 | 1.00 |

Conductive Polymer Hybrid Aluminum Electrolytic Capacitors
Surface Mount Type

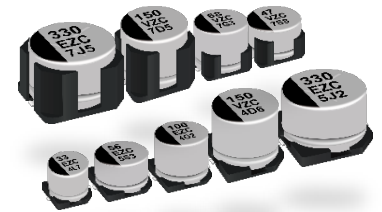

ZC series **High temperature lead-free reflow**

Features

- Endurance: 4000 h at 125 °C (High temperature / Long life)
- Low ESR and high ripple current (over 85% lower ESR than V-TP)
- High-withstand voltage (to 80 V)
- Characteristics dependencies in frequency and low temperature are as small as polymer type
- Vibration-proof product is available upon request (ø6.3, ø8, ø10)
- AEC-Q200 compliant
- RoHS compliant

Specifications

| Size code | C | D | D8 | F | G |
|------------------------------|--|----------------------------------|-----------------|-----------------|-----------------|
| Category temp. range | -55 °C to +125 °C | | | | |
| Rated voltage range | 25 V to 50 V | 25 V to 63 V | | 25 V to 80 V | |
| Nominal capacitance range | 10 µF to 33 µF | 10 µF to 56 µF | 22 µF to 100 µF | 22 µF to 220 µF | 33 µF to 330 µF |
| Capacitance tolerance | ±20 % (120 Hz / +20 °C) | | | | |
| Leakage current | I ≤ 0.01 CV (µA), 2 minutes after reaching rated voltage, 20 °C *CV = (Capacitance in µF) x (Rated voltage in V) | | | | |
| Dissipation factor (tan δ) | Please see the attached characteristics list | | | | |
| Surge voltage (V) | Rated voltage × 1.25 (15 °C to 35 °C) | | | | |
| Endurance 1 | +125 °C ± 2 °C, 4000 h, apply the rated ripple current without exceeding the rated voltage. | | | | |
| | Capacitance change | Within ±30% of the initial value | | | |
| | Dissipation factor (tan δ) | ≤ 200 % of the initial limit | | | |
| | ESR | ≤ 200 % of the initial limit | | | |
| Endurance 2 | +125 °C ± 2 °C, 3000 h, apply the rated ripple current without exceeding the rated voltage. | | | | |
| | Capacitance change | Within ±30% of the initial value | | | |
| | Dissipation factor (tan δ) | ≤ 200 % of the initial limit | | | |
| | ESR | ≤ 300 % of the initial limit | | | |
| Shelf life | After storage for 1000 hours at +125 °C ± 2 °C with no voltage applied and then being stabilized at +20 °C, capacitors shall meet the limits specified in endurance. (Capacitors are left at room temperature and humidity for 2 hours after the test. Then, apply the rated voltage for 30min with a series protection resistance of 1000 Ω ± 10 Ω. Measure electrical characteristics after discharging the capacitor.) | | | | |
| | +85 °C ± 2 °C, 85 % to 90 %RH, 2000 h, rated voltage applied | | | | |
| Damp heat (Load) | Capacitance change | | | | |
| | Dissipation factor (tan δ) | | | | |
| | ESR | | | | |
| | Leakage current | | | | |
| Resistance to soldering heat | After reflow soldering and then being stabilized at +20 °C, capacitors shall meet the following limits. | | | | |
| | Capacitance change | | | | |
| | Dissipation factor (tan δ) | | | | |
| Leakage current | | | | | |

Marking

Example : 25 V 33 µF
Marking color : BLACK
Negative polarity marking (-)

Capacitance (µF)
Series identification
Rated voltage code
Lot number

| R. voltage code | Unit : V |
|-----------------|----------|
| E | 25 |
| V | 35 |
| H | 50 |
| J | 63 |
| K | 80 |

Dimensions (not to scale)

[Standard]

| Size code | øD | L | A, B | H max. | I | W | P | K |
|-----------|------|----------|------|--------|-----|----------|-----|--|
| C | 5.0 | 5.8±0.3 | 5.3 | 6.5 | 2.2 | 0.65±0.1 | 1.5 | 0.35 ^{+0.15} _{-0.20} |
| D | 6.3 | 5.8±0.3 | 6.6 | 7.8 | 2.6 | 0.65±0.1 | 1.8 | 0.35 ^{+0.15} _{-0.20} |
| D8 | 6.3 | 7.7±0.3 | 6.6 | 7.8 | 2.6 | 0.65±0.1 | 1.8 | 0.35 ^{+0.15} _{-0.20} |
| F | 8.0 | 10.2±0.3 | 8.3 | 10 | 3.4 | 0.90±0.2 | 3.1 | 0.70±0.2 |
| G | 10.0 | 10.2±0.3 | 10.3 | 12.0 | 3.5 | 0.90±0.2 | 4.6 | 0.70±0.2 |

[Vibration-proof product]
< Size code : D, D8 >

| Size code | øD | L | A, B | H max. | F | I | W | P | K | R | S | T |
|-----------|------|----------|------|--------|------------|-----|----------|-----|--|----------|-----|----------|
| D | 6.3 | 6.1±0.3 | 6.6 | 7.8 | 0 to +0.15 | 2.4 | 0.65±0.1 | 2.2 | 0.35 ^{+0.15} _{-0.20} | 1.1±0.2 | 3.3 | 1.05±0.2 |
| D8 | 6.3 | 8.0±0.3 | 6.6 | 7.8 | 0 to +0.15 | 2.4 | 0.65±0.1 | 2.2 | 0.35 ^{+0.15} _{-0.20} | 1.1±0.2 | 3.3 | 1.05±0.2 |
| F | 8.0 | 10.5±0.3 | 8.3 | 10.0 | 0 to +0.15 | 3.4 | 1.2±0.2 | 3.1 | 0.70±0.2 | 0.70±0.2 | 5.3 | 1.3±0.2 |
| G | 10.0 | 10.5±0.3 | 10.3 | 12.0 | 0 to +0.15 | 3.5 | 1.2±0.2 | 4.6 | 0.70±0.2 | 0.70±0.2 | 6.9 | 1.3±0.2 |

Explanation of part numbers

◆ **Part number system** e.g.: EEH^{ZC}1E²²⁰X^R

| Product classification | ZC | | 1E | | 220 | | X | | R | | | |
|------------------------|--------|------|-------------------|--------|------------------|------|------------------|------|-----------------------|------|-----------------|------|
| | Series | Code | Rated voltage (V) | Code * | Capacitance (μF) | Code | Capacitance (μF) | Code | D8 size** øDxL(mm) | Code | Tape width (mm) | Code |
| | ZC | ZC | 25 | 1E | 10 | 100 | 100 | 101 | 6.3 x 7.7 | X | 12 | R |
| | | | 35 | 1V | 22 | 220 | 120 | 121 | | | 16 to 24 | P |
| | | | 50 | 1H | 33 | 330 | 150 | 151 | | | | |
| | | | 63 | 1J | 47 | 470 | 220 | 221 | | | | |
| | | | 80 | 1K | 56 | 560 | 270 | 271 | | | | |
| | | | | | 68 | 680 | 330 | 331 | | | | |
| | | | | | 82 | 820 | | | | | | |

*: If the total figures number of the part number exceeds 12 figures, "1" is omitted.
 **: Only D8 is marked with X

| Replace for the following configuration | |
|---|------|
| Configuration | Code |
| Vibration proof | V |

Characteristics list

Endurance 1 : 125 °C 4000 h

Endurance 2 : 125 °C 3000 h

| Rated voltage (V) | Capacitance (±20 %) (μF) | Case size (mm) | | | Size code | Specification | | | | Part number | | Min. packaging q'ty (pcs) |
|-------------------|--------------------------|----------------|----------|-----------------|-----------|---------------------------------------|------------------------|---------------------|------------------|---------------------------|---------------------------|---------------------------|
| | | øD | L | | | Ripple current ^{*1} (mA rms) | ESR ^{*2} (mΩ) | tan δ ^{*3} | Standard product | Vibration-proof product | Taping | |
| | | | Standard | Vibration-proof | | | | | | | | Endurance 1 |
| 25 | 22 | 5.0 | 5.8 | — | C | 550 | — | 80 | 0.14 | EEH ^{ZC} 1E220R | — | 1000 |
| | 33 | 5.0 | 5.8 | — | C | 550 | — | 80 | 0.14 | EEH ^{ZC} 1E330R | — | 1000 |
| | 47 | 6.3 | 5.8 | 6.1 | D | 900 | — | 50 | 0.14 | EEH ^{ZC} 1E470P | EEH ^{ZC} 1E470V | 1000 |
| | 56 | 6.3 | 5.8 | 6.1 | D | 900 | — | 50 | 0.14 | EEH ^{ZC} 1E560P | EEH ^{ZC} 1E560V | 1000 |
| | 68 | 6.3 | 7.7 | 8.0 | D8 | 1400 | — | 30 | 0.14 | EEH ^{ZC} 1E680XP | EEH ^{ZC} 1E680XV | 900 |
| | 100 | 6.3 | 7.7 | 8.0 | D8 | 1400 | — | 30 | 0.14 | EEH ^{ZC} 1E101XP | EEH ^{ZC} 1E101XV | 900 |
| | 150 | 8.0 | 10.2 | 10.5 | F | 1600 | 1900 | 27 | 0.14 | EEH ^{ZC} 1E151P | EEH ^{ZC} 1E151V | 500 |
| | 220 | 8.0 | 10.2 | 10.5 | F | 1600 | 1900 | 27 | 0.14 | EEH ^{ZC} 1E221P | EEH ^{ZC} 1E221V | 500 |
| 35 | 330 | 10.0 | 10.2 | 10.5 | G | 2000 | 2900 | 20 | 0.14 | EEH ^{ZC} 1E331P | EEH ^{ZC} 1E331V | 500 |
| | 10 | 5.0 | 5.8 | — | C | 550 | — | 100 | 0.12 | EEH ^{ZC} 1V100R | — | 1000 |
| | 22 | 5.0 | 5.8 | — | C | 550 | — | 100 | 0.12 | EEH ^{ZC} 1V220R | — | 1000 |
| | 33 | 6.3 | 5.8 | 6.1 | D | 900 | — | 60 | 0.12 | EEH ^{ZC} 1V330P | EEH ^{ZC} 1V330V | 1000 |
| | 47 | 6.3 | 5.8 | 6.1 | D | 900 | — | 60 | 0.12 | EEH ^{ZC} 1V470P | EEH ^{ZC} 1V470V | 1000 |
| | 68 | 6.3 | 7.7 | 8.0 | D8 | 1400 | — | 35 | 0.12 | EEH ^{ZC} 1V680XP | EEH ^{ZC} 1V680XV | 900 |
| | 100 | 8.0 | 10.2 | 10.5 | F | 1600 | 1900 | 27 | 0.12 | EEH ^{ZC} 1V101P | EEH ^{ZC} 1V101V | 500 |
| | 150 | 8.0 | 10.2 | 10.5 | F | 1600 | 1900 | 27 | 0.12 | EEH ^{ZC} 1V151P | EEH ^{ZC} 1V151V | 500 |
| 50 | 220 | 10.0 | 10.2 | 10.5 | G | 2000 | 2800 | 20 | 0.12 | EEH ^{ZC} 1V221P | EEH ^{ZC} 1V221V | 500 |
| | 270 | 10.0 | 10.2 | 10.5 | G | 2000 | 2800 | 20 | 0.12 | EEH ^{ZC} 1V271P | EEH ^{ZC} 1V271V | 500 |
| | 10 | 5.0 | 5.8 | — | C | 500 | — | 120 | 0.10 | EEH ^{ZC} 1H100R | — | 1000 |
| | 22 | 6.3 | 5.8 | 6.1 | D | 750 | — | 80 | 0.10 | EEH ^{ZC} 1H220P | EEH ^{ZC} 1H220V | 1000 |
| | 33 | 6.3 | 7.7 | 8.0 | D8 | 1100 | — | 40 | 0.10 | EEH ^{ZC} 1H330XP | EEH ^{ZC} 1H330XV | 900 |
| | 47 | 8.0 | 10.2 | 10.5 | F | 1250 | — | 30 | 0.10 | EEH ^{ZC} 1H470P | EEH ^{ZC} 1H470V | 500 |
| | 68 | 8.0 | 10.2 | 10.5 | F | 1250 | — | 30 | 0.10 | EEH ^{ZC} 1H680P | EEH ^{ZC} 1H680V | 500 |
| | 100 | 10.0 | 10.2 | 10.5 | G | 1600 | — | 28 | 0.10 | EEH ^{ZC} 1H101P | EEH ^{ZC} 1H101V | 500 |
| 63 | 120 | 10.0 | 10.2 | 10.5 | G | 1600 | — | 28 | 0.10 | EEH ^{ZC} 1H121P | EEH ^{ZC} 1H121V | 500 |
| | 10 | 6.3 | 5.8 | 6.1 | D | 700 | — | 120 | 0.08 | EEH ^{ZC} 1J100P | EEH ^{ZC} 1J100V | 1000 |
| | 22 | 6.3 | 7.7 | 8.0 | D8 | 900 | — | 80 | 0.08 | EEH ^{ZC} 1J220XP | EEH ^{ZC} 1J220XV | 900 |
| | 33 | 8.0 | 10.2 | 10.5 | F | 1100 | — | 40 | 0.08 | EEH ^{ZC} 1J330P | EEH ^{ZC} 1J330V | 500 |
| | 47 | 8.0 | 10.2 | 10.5 | F | 1100 | — | 40 | 0.08 | EEH ^{ZC} 1J470P | EEH ^{ZC} 1J470V | 500 |
| | 56 | 10.0 | 10.2 | 10.5 | G | 1400 | — | 30 | 0.08 | EEH ^{ZC} 1J560P | EEH ^{ZC} 1J560V | 500 |
| | 68 | 10.0 | 10.2 | 10.5 | G | 1400 | — | 30 | 0.08 | EEH ^{ZC} 1J680P | EEH ^{ZC} 1J680V | 500 |
| | 82 | 10.0 | 10.2 | 10.5 | G | 1400 | — | 30 | 0.08 | EEH ^{ZC} 1J820P | EEH ^{ZC} 1J820V | 500 |
| 80 | 22 | 8.0 | 10.2 | 10.5 | F | 1050 | — | 45 | 0.08 | EEH ^{ZC} 1K220P | EEH ^{ZC} 1K220V | 500 |
| | 33 | 10.0 | 10.2 | 10.5 | G | 1360 | — | 36 | 0.08 | EEH ^{ZC} 1K330P | EEH ^{ZC} 1K330V | 500 |
| | 47 | 10.0 | 10.2 | 10.5 | G | 1360 | — | 36 | 0.08 | EEH ^{ZC} 1K470P | EEH ^{ZC} 1K470V | 500 |

*1: Ripple current (100 kHz / +125 °C) *2: ESR (100 kHz / +20 °C) *3: tan δ (120 Hz / +20 °C)

- ◆ Please refer to the page of "Reflow profile" and "The taping dimensions".
- ◆ The dimensions of the vibration-proof products, please refer to the page of the mounting specification.

Frequency correction factor for ripple current

| Rated capacitance (C) | Frequency (f) | 100 Hz ≤ f < 200 Hz | 200 Hz ≤ f < 300 Hz | 300 Hz ≤ f < 500 Hz | 500 Hz ≤ f < 1 kHz |
|-----------------------|-------------------|---------------------|----------------------|-----------------------|---------------------|
| C < 47 μF | Correction factor | 0.10 | 0.10 | 0.15 | 0.20 |
| 47 μF ≤ C < 150 μF | | 0.15 | 0.20 | 0.25 | 0.30 |
| 150 μF ≤ C | | 0.15 | 0.25 | 0.25 | 0.30 |
| Rated capacitance (C) | Frequency (f) | 1 kHz ≤ f < 2 kHz | 2 kHz ≤ f < 3 kHz | 3 kHz ≤ f < 5 kHz | 5 kHz ≤ f < 10 kHz |
| C < 47 μF | Correction factor | 0.30 | 0.40 | 0.45 | 0.50 |
| 47 μF ≤ C < 150 μF | | 0.40 | 0.45 | 0.55 | 0.60 |
| 150 μF ≤ C | | 0.45 | 0.50 | 0.60 | 0.65 |
| Rated capacitance (C) | Frequency (f) | 10 kHz ≤ f < 15 kHz | 15 kHz ≤ f < 20 kHz | 20 kHz ≤ f < 30 kHz | 30 kHz ≤ f < 40 kHz |
| C < 47 μF | Correction factor | 0.60 | 0.65 | 0.70 | 0.75 |
| 47 μF ≤ C < 150 μF | | 0.70 | 0.75 | 0.80 | 0.80 |
| 150 μF ≤ C | | 0.75 | 0.80 | 0.85 | 0.85 |
| Rated capacitance (C) | Frequency (f) | 40 kHz ≤ f < 50 kHz | 50 kHz ≤ f < 100 kHz | 100 kHz ≤ f < 500 kHz | 500 kHz ≤ f |
| C < 47 μF | Correction factor | 0.80 | 0.85 | 1.00 | 1.05 |
| 47 μF ≤ C < 150 μF | | 0.85 | 0.90 | 1.00 | 1.00 |
| 150 μF ≤ C | | 0.85 | 0.90 | 1.00 | 1.00 |

After endurance ESR (100 kHz, -40°C)

| Size code | C | D | D8 | F | G |
|-----------|---|-----|-----|-----|-----|
| ESR (Ω) | 2 | 1.4 | 0.8 | 0.4 | 0.3 |

Conductive Polymer Hybrid Aluminum Electrolytic Capacitors
Surface Mount Type

ZK series High temperature lead-free reflow

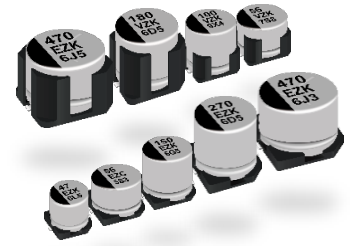

Features

- High capacitance and High ripple current compared with ZC series
- Endurance : 4000 h at 125 °C (High temperature / Long life)
- Low ESR
- Characteristics dependencies in frequency and low temperature are as small as polymer type
- Vibration-proof product is available upon request (ø6.3, ø8, ø10)
- AEC-Q200 compliant
- RoHS compliant

Specifications

| Size code | C | D | D8 | F | G |
|---|---|----------------------------------|------------------|------------------|------------------|
| Category temp. range | -55 °C to +125 °C | | | | |
| Rated voltage range | 25 V to 35 V | | | | |
| Nominal capacitance range | 33 µF to 47 µF | 56 µF to 82 µF | 100 µF to 150 µF | 180 µF to 270 µF | 330 µF to 470 µF |
| Capacitance tolerance | ±20 % (120 Hz / +20 °C) | | | | |
| Leakage current | I ≤ 0.01 CV (µA), 2 minutes after reaching rated voltage, 20 °C *CV = (Capacitance in µF) x (Rated voltage in V) | | | | |
| Dissipation factor (tan δ) | Please see the attached characteristics list | | | | |
| Surge voltage (V) | Rated voltage × 1.25 (15 °C to 35 °C) | | | | |
| Endurance | +125 °C ± 2 °C, 4000 h, apply the rated ripple current without exceeding the rated voltage. | | | | |
| | Capacitance change | Within ±30% of the initial value | | | |
| | Dissipation factor (tan δ) | ≤ 200 % of the initial limit | | | |
| | ESR | ≤ 200 % of the initial limit | | | |
| | Leakage current | Within the initial limit | | | |
| ESR after endurance (Ω / 100 kHz)(-40 °C) | Size code | | | | |
| | C | D | D8 | F | G |
| | 2.0 | 1.4 | 0.8 | 0.4 | 0.3 |
| Shelf life | After storage for 1000 hours at +125 °C ± 2 °C with no voltage applied and then being stabilized at +20 °C, capacitors shall meet the limits specified in endurance. (Capacitors are left at room temperature and humidity for 2 hours after the test. Then, apply the rated voltage for 30min with a series protection resistance of 1000 Ω ± 10 Ω. Measure electrical characteristics after discharging the capacitor.) | | | | |
| Damp heat (Load) | +85 °C ± 2 °C, 85 % to 90 %RH, 2000 h, rated voltage applied | | | | |
| | Capacitance change | Within ±30% of the initial value | | | |
| | Dissipation factor (tan δ) | ≤ 200 % of the initial limit | | | |
| | ESR | ≤ 200 % of the initial limit | | | |
| | Leakage current | Within the initial limit | | | |
| Resistance to soldering heat | After reflow soldering and then being stabilized at +20 °C, capacitors shall meet the following limits. | | | | |
| | Capacitance change | Within ±10% of the initial value | | | |
| | Dissipation factor (tan δ) | Within the initial limit | | | |
| | Leakage current | Within the initial limit | | | |

Marking

Example : 25 V 47 µF
Marking color : BLACK

Negative polarity marking (-)

Capacitance (µF)

Series identification

Rated voltage code

Lot number

| R. voltage code | Unit : V |
|-----------------|----------|
| E | 25 |
| V | 35 |

Dimensions (not to scale)

[Standard]

Pressure relief (ø10 ±)

() Reference size

| Size code | øD | L | A, B | H _{max.} | I | W | P | K |
|-----------|------|----------|------|-------------------|-----|----------|-----|--|
| C | 5.0 | 5.8±0.3 | 5.3 | 6.5 | 2.2 | 0.65±0.1 | 1.5 | 0.35 ^{+0.15} _{-0.20} |
| D | 6.3 | 5.8±0.3 | 6.6 | 7.8 | 2.6 | 0.65±0.1 | 1.8 | 0.35 ^{+0.15} _{-0.20} |
| D8 | 6.3 | 7.7±0.3 | 6.6 | 7.8 | 2.6 | 0.65±0.1 | 1.8 | 0.35 ^{+0.15} _{-0.20} |
| F | 8.0 | 10.2±0.3 | 8.3 | 10 | 3.4 | 0.90±0.2 | 3.1 | 0.70±0.2 |
| G | 10.0 | 10.2±0.3 | 10.3 | 12.0 | 3.5 | 0.90±0.2 | 4.6 | 0.70±0.2 |

Unit : mm

[Vibration-proof product]

< Size code : D, D8 >

Supportive terminals () Reference size

< Size code : F, G >

Pressure relief (ø10 ±) Supportive terminals () Reference size

| Size code | øD | L | A, B | H _{max.} | F | I | W | P | K | R | S | T |
|-----------|------|----------|------|-------------------|------------|-----|----------|-----|--|----------|-----|----------|
| D | 6.3 | 6.1±0.3 | 6.6 | 7.8 | 0 to +0.15 | 2.4 | 0.65±0.1 | 2.2 | 0.35 ^{+0.15} _{-0.20} | 1.1±0.2 | 3.3 | 1.05±0.2 |
| D8 | 6.3 | 8.0±0.3 | 6.6 | 7.8 | 0 to +0.15 | 2.4 | 0.65±0.1 | 2.2 | 0.35 ^{+0.15} _{-0.20} | 1.1±0.2 | 3.3 | 1.05±0.2 |
| F | 8.0 | 10.5±0.3 | 8.3 | 10.0 | 0 to +0.15 | 3.4 | 1.2±0.2 | 3.1 | 0.70±0.2 | 0.70±0.2 | 5.3 | 1.3±0.2 |
| G | 10.0 | 10.5±0.3 | 10.3 | 12.0 | 0 to +0.15 | 3.5 | 1.2±0.2 | 4.6 | 0.70±0.2 | 0.70±0.2 | 6.9 | 1.3±0.2 |

Unit : mm

Explanation of part numbers

◆ Part number system e.g.: EEHZK1E470R

| | | | | | | | | | | | | |
|------------------------|-----------|------|-------------------|--------|------------------|------|------------------|----------|-----------------------|------|-----------------|------|
| EEH | ZK | | 1E | | 471 | | X | R | | | | |
| Product classification | Series | Code | Rated voltage (V) | Code * | Capacitance (μF) | Code | Capacitance (μF) | Code | D8 size** øDxL(mm) | Code | Tape width (mm) | Code |
| | ZK | ZK | 25 | 1E | 33 | 330 | 150 | 151 | 6.3 x 7.7 | X | 16 to 24 | P |
| | | | 35 | 1V | 47 | 470 | 180 | 181 | | | | |
| | | | | | 56 | 560 | 270 | 271 | | | | |
| | | | | | 68 | 680 | 330 | 331 | | | | |
| | | | | | 82 | 820 | 470 | 471 | | | | |
| | | | | | 100 | 101 | | | | | | |

| | |
|---|------|
| Replace for the following configuration | |
| Configuration | Code |
| Vibration proof | V |

*: If the total figures number of the part number exceeds 12 figures, "1" is omitted.
 **: Only D8 is marked with X

Characteristics list

Endurance : 125 °C 4000 h

| Rated voltage (V) | Capacitance (±20 %) (μF) | Case size (mm) | | | Size code | Specification | | | Part number | | Min. packaging q'ty (pcs) |
|-------------------|--------------------------|----------------|----------|-----------------|-----------|---------------------------|------------|---------|------------------|-------------------------|---------------------------|
| | | øD | L | | | Ripple current*1 (mA rms) | ESR*2 (mΩ) | tan δ*3 | Standard product | Vibration-proof product | Taping |
| | | | Standard | Vibration-proof | | | | | | | |
| 25 | 47 | 5.0 | 5.8 | — | C | 850 | 80 | 0.14 | EEHZK1E470R | — | 1000 |
| | 68 | 6.3 | 5.8 | 6.1 | D | 1300 | 50 | 0.14 | EEHZK1E680P | EEHZK1E680V | 1000 |
| | 82 | 6.3 | 5.8 | 6.1 | D | 1300 | 50 | 0.14 | EEHZK1E820P | EEHZK1E820V | 1000 |
| | 150 | 6.3 | 7.7 | 8.0 | D8 | 1800 | 30 | 0.14 | EEHZK1E151XP | EEHZK1E151XV | 900 |
| | 270 | 8.0 | 10.2 | 10.5 | F | 2000 | 27 | 0.14 | EEHZK1E271P | EEHZK1E271V | 500 |
| 35 | 470 | 10.0 | 10.2 | 10.5 | G | 2800 | 20 | 0.14 | EEHZK1E471P | EEHZK1E471V | 500 |
| | 33 | 5.0 | 5.8 | — | C | 750 | 100 | 0.12 | EEHZK1V330R | — | 1000 |
| | 56 | 6.3 | 5.8 | 6.1 | D | 1200 | 60 | 0.12 | EEHZK1V560P | EEHZK1V560V | 1000 |
| | 100 | 6.3 | 7.7 | 8.0 | D8 | 1700 | 35 | 0.12 | EEHZK1V101XP | EEHZK1V101XV | 900 |
| | 180 | 8.0 | 10.2 | 10.5 | F | 2000 | 27 | 0.12 | EEHZK1V181P | EEHZK1V181V | 500 |
| | 330 | 10.0 | 10.2 | 10.5 | G | 2800 | 20 | 0.12 | EEHZK1V331P | EEHZK1V331V | 500 |

*1: Ripple current (100 kHz / +125 °C)

*2: ESR (100 kHz / +20 °C)

*3: tan δ (120 Hz / +20 °C)

◆ Please refer to the page of "Reflow profile" and "The taping dimensions".

◆ The dimensions of the vibration-proof products, please refer to the page of the mounting specification.

Frequency correction factor for ripple current

| Rated capacitance (C) | Frequency (f) | 100 Hz ≤ f < 200 Hz | 200 Hz ≤ f < 300 Hz | 300 Hz ≤ f < 500 Hz | 500 Hz ≤ f < 1 kHz |
|-----------------------|-------------------|---------------------|---------------------|---------------------|--------------------|
| C < 47 μF | Correction factor | 0.15 | 0.20 | 0.25 | 0.35 |
| 47 μF ≤ C < 100 μF | | 0.15 | 0.25 | 0.30 | 0.40 |
| 100 μF ≤ C | | 0.15 | 0.25 | 0.30 | 0.40 |

| Rated capacitance (C) | Frequency (f) | 1 kHz ≤ f < 2 kHz | 2 kHz ≤ f < 3 kHz | 3 kHz ≤ f < 5 kHz | 5 kHz ≤ f < 10 kHz |
|-----------------------|-------------------|-------------------|-------------------|-------------------|--------------------|
| C < 47 μF | Correction factor | 0.45 | 0.55 | 0.60 | 0.65 |
| 47 μF ≤ C < 100 μF | | 0.50 | 0.60 | 0.65 | 0.70 |
| 100 μF ≤ C | | 0.50 | 0.60 | 0.65 | 0.70 |

| Rated capacitance (C) | Frequency (f) | 10 kHz ≤ f < 15 kHz | 15 kHz ≤ f < 20 kHz | 20 kHz ≤ f < 30 kHz | 30 kHz ≤ f < 40 kHz |
|-----------------------|-------------------|---------------------|---------------------|---------------------|---------------------|
| C < 47 μF | Correction factor | 0.70 | 0.75 | 0.75 | 0.75 |
| 47 μF ≤ C < 100 μF | | 0.75 | 0.75 | 0.80 | 0.80 |
| 100 μF ≤ C | | 0.75 | 0.80 | 0.85 | 0.85 |

| Rated capacitance (C) | Frequency (f) | 40 kHz ≤ f < 50 kHz | 50 kHz ≤ f < 100 kHz | 100 kHz ≤ f < 500 kHz | 500 kHz ≤ f |
|-----------------------|-------------------|---------------------|----------------------|-----------------------|-------------|
| C < 47 μF | Correction factor | 0.80 | 0.85 | 1.00 | 1.05 |
| 47 μF ≤ C < 100 μF | | 0.85 | 0.90 | 1.00 | 1.00 |
| 100 μF ≤ C | | 0.85 | 0.90 | 1.00 | 1.00 |

Conductive Polymer Hybrid Aluminum Electrolytic Capacitors
Surface Mount Type

ZKU series High temperature lead-free reflow

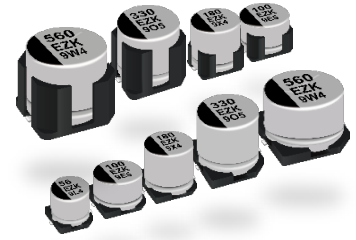

Features

- Endurance : 4000 h at 125 °C (High temperature / Long life)
- Large capacitance compared with ZK series
- Low ESR
- Characteristics dependencies in frequency and low temperature are as small as polymer type
- Vibration-proof product is available upon request. (ø6.3, ø8, ø10)
- AEC-Q200 compliant
- RoHS compliant

Specifications

| Size code | C | D | D8 | F | G |
|---|--|----------------------------------|------------------|------------------|------------------|
| Category temp. range | -55 °C to +125 °C | | | | |
| Rated voltage range | 25 V to 35 V | | | | |
| Nominal capacitance range | 39 µF to 56 µF | 68 µF to 100 µF | 120 µF to 180 µF | 220 µF to 330 µF | 390 µF to 560 µF |
| Capacitance tolerance | ±20 % (120 Hz / +20 °C) | | | | |
| Leakage current | I ≤ 0.01 CV (µA), 2 minutes after reaching rated voltage, 20 °C *CV = (Capacitance in µF) x (Rated voltage in V) | | | | |
| Dissipation factor (tan δ) | Please see the attached characteristics list | | | | |
| Surge voltage (V) | Rated voltage × 1.25 (15 °C to 35 °C) | | | | |
| Endurance | +125 °C ± 2 °C 4000 h, apply the rated ripple current without exceeding the rated voltage. | | | | |
| | Capacitance change | Within ±30% of the initial value | | | |
| | Dissipation factor (tan δ) | ≤ 200 % of the initial limit | | | |
| | ESR | ≤ 200 % of the initial limit | | | |
| | Leakage current | Within the initial limit | | | |
| ESR after endurance (Ω / 100 kHz)(-40 °C) | Size code | | | | |
| | C | D | D8 | F | G |
| | 2.0 | 1.4 | 0.8 | 0.4 | 0.3 |
| Shelf life | After storage for 1000 hours at +125 °C ± 2 °C with no voltage applied and then being stabilized at +20 °C, capacitors shall meet the limits specified in endurance. (Capacitors are left at room temperature and humidity for 2 hours after the test. Then, apply the rated voltage for 30min with a series protection resistance of 1000 Ω ± 10 Ω. Measure electrical characteristics after discharging the capacitor.) | | | | |
| Damp heat (Load) | +85 °C ± 2 °C, 85 % to 90 %RH, 2000 h, rated voltage applied | | | | |
| | Capacitance change | Within ±30% of the initial value | | | |
| | Dissipation factor (tan δ) | ≤ 200 % of the initial limit | | | |
| | ESR | ≤ 200 % of the initial limit | | | |
| | Leakage current | Within the initial limit | | | |

Marking

Example : 25 V 56 µF
Marking color : BLACK

Negative polarity marking (-)
Capacitance (µF)
Series identification
Rated voltage code
Lot number

| R. voltage code | Unit : V |
|-----------------|----------|
| E | 25 |
| V | 35 |

Dimensions (not to scale)

[Standard]

| Size code | øD | L | A, B | H _{max.} | I | W | P | K |
|-----------|------|----------|------|-------------------|-----|----------|-----|--|
| C | 5.0 | 5.8±0.3 | 5.3 | 6.5 | 2.2 | 0.65±0.1 | 1.5 | 0.35 ^{+0.15} _{-0.20} |
| D | 6.3 | 5.8±0.3 | 6.6 | 7.8 | 2.6 | 0.65±0.1 | 1.8 | 0.35 ^{+0.15} _{-0.20} |
| D8 | 6.3 | 7.7±0.3 | 6.6 | 7.8 | 2.6 | 0.65±0.1 | 1.8 | 0.35 ^{+0.15} _{-0.20} |
| F | 8.0 | 10.2±0.3 | 8.3 | 10 | 3.4 | 0.90±0.2 | 3.1 | 0.70±0.2 |
| G | 10.0 | 10.2±0.3 | 10.3 | 12.0 | 3.5 | 0.90±0.2 | 4.6 | 0.70±0.2 |

[Vibration-proof product]
< Size code : D, D8 >

< Size code : F, G >

| Size code | øD | L | A, B | H _{max.} | F | I | W | P | K | R | S | T |
|-----------|------|----------|------|-------------------|------------|-----|----------|-----|--|----------|-----|----------|
| D | 6.3 | 6.1±0.3 | 6.6 | 7.8 | 0 to +0.15 | 2.4 | 0.65±0.1 | 2.2 | 0.35 ^{+0.15} _{-0.20} | 1.1±0.2 | 3.3 | 1.05±0.2 |
| D8 | 6.3 | 8.0±0.3 | 6.6 | 7.8 | 0 to +0.15 | 2.4 | 0.65±0.1 | 2.2 | 0.35 ^{+0.15} _{-0.20} | 1.1±0.2 | 3.3 | 1.05±0.2 |
| F | 8.0 | 10.5±0.3 | 8.3 | 10.0 | 0 to +0.15 | 3.4 | 1.2±0.2 | 3.1 | 0.70±0.2 | 0.70±0.2 | 5.3 | 1.3±0.2 |
| G | 10.0 | 10.5±0.3 | 10.3 | 12.0 | 0 to +0.15 | 3.5 | 1.2±0.2 | 4.6 | 0.70±0.2 | 0.70±0.2 | 6.9 | 1.3±0.2 |

Explanation of part numbers

◆ Part number system

e.g.: EEHZKE181XUP

| EEH | ZK | | E | | 181 | | X | | U | | P | |
|------------------------|--------|------|-------------------|--------|------------------|------|------------------------|------|----------------------|------|-----------------|------|
| Product classification | Series | Code | Rated voltage (V) | Code * | Capacitance (μF) | Code | D8 size ** øDxL(mm) | Code | Dia øD | Code | Tape width (mm) | Code |
| | ZKU | ZK | 25 | 1E | 39 | 390 | 6.3 x 7.7 | X | Miniaturized product | U | 12 | R |
| | | | 35 | 1V | 56 | 560 | | | | | 16 to 24 | P |
| | | | | | 68 | 680 | | | | | | |
| | | | | | 100 | 101 | | | | | | |
| | | | | | 120 | 121 | | | | | | |
| | | | | | 180 | 181 | | | | | | |
| | | | | | 220 | 221 | | | | | | |
| | | | | | 330 | 331 | | | | | | |
| | | | | | 390 | 391 | | | | | | |
| | | | | | 560 | 561 | | | | | | |

| Replace for the following configuration | |
|---|------|
| Configuration | Code |
| Vibration proof | V |

*: If the total figures number of the part number exceeds 12 figures, "1" is omitted.
 **: Only D8 is marked with X

Characteristics list

Endurance : 125 °C 4000 h

| Rated voltage (V) | Capacitance (±20 %) (μF) | Case size (mm) | | | Size code | Specification | | | Part number | | Min. packaging q'ty (pcs) |
|-------------------|--------------------------|----------------|----------|-----------------|-----------|----------------------------|------------|---------|------------------|-------------------------|---------------------------|
| | | øD | L | | | Ripple current *1 (mA rms) | ESR*2 (mΩ) | tan δ*3 | Standard product | Vibration-proof product | |
| | | | Standard | Vibration-proof | | | | | | | |
| 25 | 56 | 5 | 5.8 | - | C | 850 | 80 | 0.14 | EEHZK1E560UR | - | 1000 |
| | 100 | 6.3 | 5.8 | 6.1 | D | 1300 | 50 | 0.14 | EEHZK1E101UP | EEHZK1E101UV | 1000 |
| | 180 | 6.3 | 7.7 | 8.0 | D8 | 1800 | 30 | 0.14 | EEHZKE181XUP | EEHZKE181XUV | 900 |
| | 330 | 8 | 10.2 | 10.5 | F | 2000 | 27 | 0.14 | EEHZK1E331UP | EEHZK1E331UV | 500 |
| | 560 | 10 | 10.2 | 10.5 | G | 2800 | 20 | 0.14 | EEHZK1E561UP | EEHZK1E561UV | 500 |
| 35 | 39 | 5 | 5.8 | - | C | 750 | 100 | 0.12 | EEHZK1V390UR | - | 1000 |
| | 68 | 6.3 | 5.8 | 6.1 | D | 1200 | 60 | 0.12 | EEHZK1V680UP | EEHZK1V680UV | 1000 |
| | 120 | 6.3 | 7.7 | 8.0 | D8 | 1700 | 35 | 0.12 | EEHZKV121XUP | EEHZKV121XUV | 900 |
| | 220 | 8 | 10.2 | 10.5 | F | 2000 | 27 | 0.12 | EEHZK1V221UP | EEHZK1V221UV | 500 |
| | 390 | 10 | 10.2 | 10.5 | G | 2800 | 20 | 0.12 | EEHZK1V391UP | EEHZK1V391UV | 500 |

*1: Ripple current (100 kHz / +125 °C)

*2: ESR (100 kHz / +20 °C)

*3: tan δ (120 Hz / +20 °C)

◆ Please refer to the page of "Reflow profile" and "The taping dimensions".

◆ The dimensions of the vibration-proof products, please refer to the page of the mounting specification.

Frequency correction factor for ripple current

| Rated capacitance (C) | Frequency(f) | 100 Hz ≤ f < 200 Hz | 200 Hz ≤ f < 300 Hz | 300 Hz ≤ f < 500 Hz | 500 Hz ≤ f < 1 kHz |
|-----------------------|-------------------|---------------------|---------------------|---------------------|--------------------|
| C < 47 μF | Correction factor | 0.15 | 0.20 | 0.25 | 0.35 |
| 47 μF ≤ C < 100 μF | | 0.15 | 0.25 | 0.30 | 0.40 |
| 100 μF ≤ C | | 0.15 | 0.25 | 0.30 | 0.40 |

| Rated capacitance (C) | Frequency(f) | 1 kHz ≤ f < 2 kHz | 2 kHz ≤ f < 3 kHz | 3 kHz ≤ f < 5 kHz | 5 kHz ≤ f < 10 kHz |
|-----------------------|-------------------|-------------------|-------------------|-------------------|--------------------|
| C < 47 μF | Correction factor | 0.45 | 0.55 | 0.60 | 0.65 |
| 47 μF ≤ C < 100 μF | | 0.50 | 0.60 | 0.65 | 0.70 |
| 100 μF ≤ C | | 0.50 | 0.60 | 0.65 | 0.70 |

| Rated capacitance (C) | Frequency(f) | 10 kHz ≤ f < 15 kHz | 15 kHz ≤ f < 20 kHz | 20 kHz ≤ f < 30 kHz | 30 kHz ≤ f < 40 kHz |
|-----------------------|-------------------|---------------------|---------------------|---------------------|---------------------|
| C < 47 μF | Correction factor | 0.70 | 0.75 | 0.75 | 0.75 |
| 47 μF ≤ C < 100 μF | | 0.75 | 0.75 | 0.80 | 0.80 |
| 100 μF ≤ C | | 0.75 | 0.80 | 0.85 | 0.85 |

| Rated capacitance (C) | Frequency(f) | 40 kHz ≤ f < 50 kHz | 50 kHz ≤ f < 100 kHz | 100 kHz ≤ f < 500 kHz | 500 kHz ≤ f |
|-----------------------|-------------------|---------------------|----------------------|-----------------------|-------------|
| C < 47 μF | Correction factor | 0.80 | 0.85 | 1.00 | 1.05 |
| 47 μF ≤ C < 100 μF | | 0.85 | 0.90 | 1.00 | 1.00 |
| 100 μF ≤ C | | 0.85 | 0.90 | 1.00 | 1.00 |

Conductive Polymer Hybrid Aluminum Electrolytic Capacitors
Surface Mount Type

ZL series

High temperature lead-free reflow

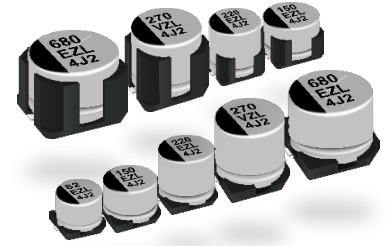

Features

- Endurance : 4000 h at 125 °C / 135 °C
- Higher capacitance (max 150 % of ZKU series)
- AEC-Q200 compliant
- Smaller than ZC series with the same capacitance
- Low ESR (max 40 %, lower ESR than ZC or ZKU series)
- RoHS compliant

Specifications

| Size code | C | D | D8 | F | G |
|----------------------------|--|-----------------------------------|------------------|------------------|------------------|
| Category temp. range | -55 °C to +135 °C | | | | |
| Rated voltage range | 25 V to 35 V | | | | |
| Nominal capacitance range | 47 μF to 82 μF | 82 μF to 150 μF | 150 μF to 220 μF | 270 μF to 470 μF | 470 μF to 680 μF |
| Capacitance tolerance | ±20 % (120 Hz / +20 °C) | | | | |
| Leakage current | I ≤ 0.01 CV (μA), 2 minutes after reaching rated voltage, 20 °C *CV = (Capacitance in μF) x (Rated voltage in V) | | | | |
| Dissipation factor (tan δ) | Please see the attached characteristics list | | | | |
| Surge voltage (V) | Rated voltage × 1.25 (15 °C to 35 °C) | | | | |
| Endurance 1 | +125 °C ± 2 °C 4000 h, apply the rated ripple current without exceeding the rated voltage. | | | | |
| | Capacitance change | Within ±30% of the initial value | | | |
| | Dissipation factor (tan δ) | ≤ 200 % of the initial limit | | | |
| | ESR | ≤ 200 % of the initial limit | | | |
| | Leakage current | Within the initial limit | | | |
| Endurance 2 | +135 °C ± 2 °C 2000 h (C,D,D8 size) or 4000 h (F,G size), apply the rated ripple current without exceeding the rated voltage. | | | | |
| | Capacitance change | Within ±30% of the initial value | | | |
| | Dissipation factor (tan δ) | ≤ 200 % of the initial limit | | | |
| | ESR | ≤ 200 % of the initial limit | | | |
| | Leakage current | Within the initial limit | | | |
| Shelf life | After storage for 1000 hours at +135 °C ± 2 °C with no voltage applied and then being stabilized at +20 °C, capacitors shall meet the limits specified in endurance. (Capacitors are left at room temperature and humidity for 2 hours after the test. Then, apply the rated voltage for 30min with a series protection resistance of 1000 Ω ± 10 Ω. Measure electrical characteristics after discharging the capacitor.) | | | | |
| | +85 °C ± 2 °C, 85 % to 90 %RH, 2000 h, rated voltage applied | | | | |
| | Capacitance change | Within ±30% of the initial value | | | |
| | Dissipation factor (tan δ) | ≤ 200 % of the initial limit | | | |
| | ESR | ≤ 200 % of the initial limit | | | |
| Damp heat (Load) | After reflow soldering and then being stabilized at +20 °C, capacitors shall meet the following limits. | | | | |
| | Capacitance change | Within ±10 % of the initial value | | | |
| | Dissipation factor (tan δ) | Within the initial limit | | | |
| | Leakage current | Within the initial limit | | | |
| | Resistance to soldering heat | Within the initial limit | | | |

Marking

Example : 25 V 470 μF
Marking color : BLACK

Negative polarity marking (-)
Capacitance (μF)
Series identification
Rated voltage code
Lot number

| R. voltage code | Unit : V |
|-----------------|----------|
| E | 25 |
| V | 35 |

Dimensions (not to scale)

[Standard]

| Size code | øD | L | A, B | H _{max} | I | W | P | K |
|-----------|------|----------|------|------------------|-----|----------|-----|--|
| C | 5.0 | 5.8±0.3 | 5.3 | 6.5 | 2.2 | 0.65±0.1 | 1.5 | 0.35 ^{+0.15} _{-0.20} |
| D | 6.3 | 5.8±0.3 | 6.6 | 7.8 | 2.6 | 0.65±0.1 | 1.8 | 0.35 ^{+0.15} _{-0.20} |
| D8 | 6.3 | 7.7±0.3 | 6.6 | 7.8 | 2.6 | 0.65±0.1 | 1.8 | 0.35 ^{+0.15} _{-0.20} |
| F | 8.0 | 10.2±0.3 | 8.3 | 10 | 3.4 | 0.90±0.2 | 3.1 | 0.70±0.2 |
| G | 10.0 | 10.2±0.3 | 10.3 | 12.0 | 3.5 | 0.90±0.2 | 4.6 | 0.70±0.2 |

[Vibration-proof product]
< Size code : D, D8 >

| Size code | øD | L | A, B | H _{max} | F | I | W | P | K | R | S | T |
|-----------|------|----------|------|------------------|------------|-----|----------|-----|--|----------|-----|----------|
| D | 6.3 | 6.1±0.3 | 6.6 | 7.8 | 0 to +0.15 | 2.4 | 0.65±0.1 | 2.2 | 0.35 ^{+0.15} _{-0.20} | 1.1±0.2 | 3.3 | 1.05±0.2 |
| D8 | 6.3 | 8.0±0.3 | 6.6 | 7.8 | 0 to +0.15 | 2.4 | 0.65±0.1 | 2.2 | 0.35 ^{+0.15} _{-0.20} | 1.1±0.2 | 3.3 | 1.05±0.2 |
| F | 8.0 | 10.5±0.3 | 8.3 | 10.0 | 0 to +0.15 | 3.4 | 1.2±0.2 | 3.1 | 0.70±0.2 | 0.70±0.2 | 5.3 | 1.3±0.2 |
| G | 10.0 | 10.5±0.3 | 10.3 | 12.0 | 0 to +0.15 | 3.5 | 1.2±0.2 | 4.6 | 0.70±0.2 | 0.70±0.2 | 6.9 | 1.3±0.2 |

< Size code : F, G >

Explanation of part numbers

◆ Part number system

e.g.: EEH^{ZL}1E221XP

| Product classification | ZL | | 1E | | 221 | | X | | P | | | |
|------------------------|--------|------|-------------------|--------|------------------|------|------------------|------|-----------------------|------|-----------------|------|
| | Series | Code | Rated voltage (V) | Code * | Capacitance (μF) | Code | Capacitance (μF) | Code | D8 size** øDxL(mm) | Code | Tape width (mm) | Code |
| | ZL | ZL | 25 | 1E | 47 | 470 | 270 | 271 | 6.3 x 7.7 | X | 12 | R |
| | | | 35 | 1V | 82 | 820 | 470 | 471 | | | 16 to 24 | P |
| | | | | | 150 | 151 | 680 | 681 | | | | |
| | | | | | 220 | 221 | | | | | | |

| Replace for the following configuration | |
|---|------|
| Configuration | Code |
| Vibration proof | V |

*: If the total figures number of the part number exceeds 12 figures, "1" is omitted.
 **: Only D8 is marked with X

Characteristics list

Endurance 1 : 125 °C 4000 h

Endurance 2 : 135 °C 2000 h (C, D, D8 size) / 4000 h (F, G size)

| Rated voltage (V) | Capacitance (±20 %) (μF) | Case size (mm) | | | Size code | Specification | | | | Part number | | Min. packaging q'ty (pcs) |
|-------------------|--------------------------|----------------|----------|-----------------|-----------|---------------------------------------|------------------------|---------------------|------------------|---------------------------|---------------------------|---------------------------|
| | | øD | L | | | Ripple current ^{*1} (mA rms) | ESR ^{*2} (mΩ) | tan δ ^{*3} | Standard product | Vibration-proof product | Taping | |
| | | | Standard | Vibration-proof | | | | | | | | Endurance 1 (+125°C) |
| 25 | 82 | 5.0 | 5.8 | - | C | 1000 | 600 | 58 | 0.14 | EEH ^{ZL} 1E820R | - | 1000 |
| | 150 | 6.3 | 5.8 | 6.1 | D | 1500 | 800 | 38 | 0.14 | EEH ^{ZL} 1E151P | EEH ^{ZL} 1E151V | 1000 |
| | 220 | 6.3 | 7.7 | 8.0 | D8 | 2000 | 1000 | 24 | 0.14 | EEH ^{ZL} 1E221XP | EEH ^{ZL} 1E221XV | 900 |
| | 470 | 8.0 | 10.2 | 10.5 | F | 3000 | 2000 | 18 | 0.14 | EEH ^{ZL} 1E471P | EEH ^{ZL} 1E471V | 500 |
| | 680 | 10.0 | 10.2 | 10.5 | G | 3400 | 2300 | 14 | 0.14 | EEH ^{ZL} 1E681P | EEH ^{ZL} 1E681V | 500 |
| 35 | 47 | 5.0 | 5.8 | - | C | 900 | 550 | 60 | 0.12 | EEH ^{ZL} 1V470R | - | 1000 |
| | 82 | 6.3 | 5.8 | 6.1 | D | 1400 | 700 | 40 | 0.12 | EEH ^{ZL} 1V820P | EEH ^{ZL} 1V820V | 1000 |
| | 150 | 6.3 | 7.7 | 8.0 | D8 | 1900 | 900 | 26 | 0.12 | EEH ^{ZL} 1V151XP | EEH ^{ZL} 1V151XV | 900 |
| | 270 | 8.0 | 10.2 | 10.5 | F | 2900 | 1900 | 20 | 0.12 | EEH ^{ZL} 1V271P | EEH ^{ZL} 1V271V | 500 |
| | 470 | 10.0 | 10.2 | 10.5 | G | 3300 | 2200 | 16 | 0.12 | EEH ^{ZL} 1V471P | EEH ^{ZL} 1V471V | 500 |

*1: Ripple current (100 kHz / +125 °C or +135 °C)

*2: ESR (100 kHz / +20 °C)

*3: tan δ (120 Hz / +20 °C)

◆ Please refer to the page of "Reflow profile" and "The taping dimensions".

◆ The dimensions of the vibration-proof products, please refer to the page of the mounting specification.

Frequency correction factor for ripple current

| Rated capacitance (C) | Frequency(f) | 100 Hz ≤ f < 200 Hz | 200 Hz ≤ f < 300 Hz | 300 Hz ≤ f < 500 Hz | 500 Hz ≤ f < 1 kHz |
|-----------------------|--------------|---------------------|---------------------|---------------------|--------------------|
| 47 μF ≤ C < 150 μF | Correction | 0.15 | 0.20 | 0.25 | 0.30 |
| | factor | | | | |
| 150 μF ≤ C | | 0.15 | 0.25 | 0.25 | 0.30 |

| Rated capacitance (C) | Frequency(f) | 1 kHz ≤ f < 2 kHz | 2 kHz ≤ f < 3 kHz | 3 kHz ≤ f < 5 kHz | 5 kHz ≤ f < 10 kHz |
|-----------------------|--------------|-------------------|-------------------|-------------------|--------------------|
| 47 μF ≤ C < 150 μF | Correction | 0.40 | 0.45 | 0.55 | 0.60 |
| | factor | | | | |
| 150 μF ≤ C | | 0.45 | 0.50 | 0.60 | 0.65 |

| Rated capacitance (C) | Frequency(f) | 10 kHz ≤ f < 15 kHz | 15 kHz ≤ f < 20 kHz | 20 kHz ≤ f < 30 kHz | 30 kHz ≤ f < 40 kHz |
|-----------------------|--------------|---------------------|---------------------|---------------------|---------------------|
| 47 μF ≤ C < 150 μF | Correction | 0.70 | 0.75 | 0.80 | 0.80 |
| | factor | | | | |
| 150 μF ≤ C | | 0.75 | 0.80 | 0.85 | 0.85 |

| Rated capacitance (C) | Frequency(f) | 40 kHz ≤ f < 50 kHz | 50 kHz ≤ f < 100 kHz | 100 kHz ≤ f < 500 kHz | 500 kHz ≤ 1000 kHz |
|-----------------------|--------------|---------------------|----------------------|-----------------------|--------------------|
| 47 μF ≤ C < 150 μF | Correction | 0.85 | 0.90 | 1.00 | 1.00 |
| | factor | | | | |
| 150 μF ≤ C | | 0.85 | 0.90 | 1.00 | 1.00 |

Conductive Polymer Hybrid Aluminum Electrolytic Capacitors

Surface Mount Type

ZT series

High temperature lead-free reflow

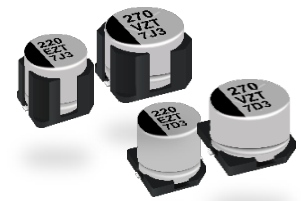

Features

- Endurance: 4000 h at 135 °C / 125 °C
- Higher ripple current (75 % to 118 % higher than ZC series)
- Vibration-proof product is available upon request.
- AEC-Q200 compliant
- RoHS compliant

Specifications

| Size code | F | G | |
|---|--|----------------------------------|-----|
| Category temp. range | -55 °C to +135 °C | | |
| Rated voltage range | 25 V to 63 V | | |
| Nominal capacitance range | 33 μF to 220 μF | 56 μF to 330 μF | |
| Capacitance tolerance | ±20 % (120 Hz / +20 °C) | | |
| Leakage current | $I \leq 0.01 CV (\mu A)$, 2 minutes after reaching rated voltage, 20 °C *CV = (Capacitance in μF) x (Rated voltage in V) | | |
| Dissipation factor (tan δ) | Please see the attached characteristics list | | |
| Surge voltage (V) | Rated voltage × 1.25 (15 °C to 35 °C) | | |
| Endurance 1 | +125 °C ± 2 °C, 4000 h, apply the rated ripple current without exceeding the rated voltage | | |
| | Capacitance change | Within ±30% of the initial value | |
| | Dissipation factor (tan δ) | ≤ 200 % of the initial limit | |
| | E.S.R. | ≤ 200 % of the initial limit | |
| | Leakage current | Within the initial limit | |
| ESR after endurance (Ω / 100 kHz)(-40 °C) | Size code | | |
| | F | G | |
| | | 0.4 | 0.3 |
| Endurance 2 | +135 °C ± 2 °C, 4000 h, apply the rated ripple current without exceeding the rated voltage | | |
| | Capacitance change | Within ±30% of the initial value | |
| | Dissipation factor (tan δ) | ≤ 200 % of the initial limit | |
| | E.S.R. | ≤ 200 % of the initial limit | |
| | Leakage current | Within the initial limit | |
| ESR after endurance (Ω / 100 kHz)(-40 °C) | Size code | | |
| | F | G | |
| | | 0.4 | 0.3 |
| Shelf life | After storage for 1000 hours at +135 °C ± 2 °C with no voltage applied and then being stabilized at +20 °C, capacitors shall meet the limits specified in endurance. (Capacitors are left at room temperature and humidity for 2 hours after the test. Then, apply the rated voltage for 30min with a series protection resistance of 1000 Ω ± 10 Ω. Measure electrical characteristics after discharging the capacitor.) | | |
| Damp heat (Load) | 85 °C ± 2 °C, 85 % to 90 %RH, 2000 h, rated voltage applied | | |
| | Capacitance change | Within ±30% of the initial value | |
| | Dissipation factor (tan δ) | ≤ 200 % of the initial limit | |
| | E.S.R. | ≤ 200 % of the initial limit | |
| Resistance to soldering heat | After reflow soldering and then being stabilized at +20 °C, capacitors shall meet the following limits. | | |
| | Capacitance change | Within ±10% of the initial value | |
| | Dissipation factor (tan δ) | Within the initial limit | |
| Leakage current | Within the initial limit | | |

Marking

Example : 25 V 220 μF
Marking color : BLACK

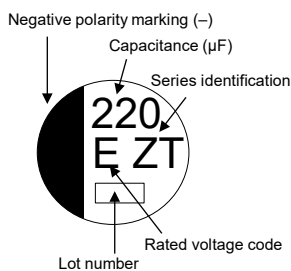

| R. voltage code | Unit : V |
|-----------------|----------|
| E | 25 |
| V | 35 |
| H | 50 |
| J | 63 |

Dimensions (not to scale)

[Standard]

[Vibration-proof product]

| Size code | øD | L | A, B | H _{max} | I | W | P | K |
|-----------|------|----------|------|------------------|-----|----------|-----|----------|
| F | 8.0 | 10.2±0.3 | 8.3 | 10.0 | 3.4 | 0.90±0.2 | 3.1 | 0.70±0.2 |
| G | 10.0 | 10.2±0.3 | 10.3 | 12.0 | 3.5 | 0.90±0.2 | 4.6 | 0.70±0.2 |

| Size code | øD | L | A, B | H _{max} | F | I | W | P | K | R | S | T |
|-----------|------|----------|------|------------------|------------|-----|---------|-----|----------|----------|-----|---------|
| F | 8.0 | 10.5±0.3 | 8.3 | 10.0 | 0 to +0.15 | 3.4 | 1.2±0.2 | 3.1 | 0.70±0.2 | 0.70±0.2 | 5.3 | 1.3±0.2 |
| G | 10.0 | 10.5±0.3 | 10.3 | 12.0 | 0 to +0.15 | 3.5 | 1.2±0.2 | 4.6 | 0.70±0.2 | 0.70±0.2 | 6.9 | 1.3±0.2 |

Explanation of part numbers

◆ Part number system

e.g.: EEH^{ZT}1E221P

| EEH | ZT | | 1E | | 221 | | P | | | |
|------------------------|--------|------|-------------------|-------|------------------|------|------------------|------|---|------|
| Product classification | Series | Code | Rated voltage (V) | Code* | Capacitance (μF) | Code | Capacitance (μF) | Code | Tape width (mm) | Code |
| | ZT | ZT | 25 | 1E | 33 | 330 | 120 | 121 | 16 to 24 | P |
| | | | 35 | 1V | 47 | 470 | 150 | 151 | | |
| | | | 50 | 1H | 56 | 560 | 220 | 221 | | |
| | | | 63 | 1J | 68 | 680 | 270 | 271 | | |
| | | | | | 82 | 820 | 330 | 331 | | |
| | | | | | 100 | 101 | | | | |
| | | | | | | | | | Replace for the following configuration | |
| | | | | | | | | | Configuration | Code |
| | | | | | | | | | Vibration proof | V |

* : If the total figures number of the part number exceeds 12 figures, "1" is omitted.

Characteristics list

Endurance 1 : 125 °C 4000 h

Endurance 2 : 135 °C 4000 h

| Rated voltage (V) | Capacitance (±20 %) (μF) | Case size (mm) | | | Size code | Specification | | | | Part number | | Min. packaging q'ty (pcs) |
|-------------------|--------------------------|----------------|----------|-----------------|-----------|---------------------------------------|------------------------|---------------------|------------------|--------------------------|--------------------------|---------------------------|
| | | øD | L | | | Ripple current ^{*1} (mA rms) | ESR ^{*2} (mΩ) | tan δ ^{*3} | Standard product | Vibration-proof product | | |
| | | | Standard | Vibration-proof | | | | | | | Endurance 1 125 °C | Endurance 2 135 °C |
| 25 | 220 | 8.0 | 10.2 | 10.5 | F | 2900 | 1800 | 22 | 0.14 | EEH ^{ZT} 1E221P | EEH ^{ZT} 1E221V | 500 |
| | 330 | 10.0 | 10.2 | 10.5 | G | 3500 | 2200 | 16 | 0.14 | EEH ^{ZT} 1E331P | EEH ^{ZT} 1E331V | 500 |
| 35 | 150 | 8.0 | 10.2 | 10.5 | F | 2900 | 1800 | 22 | 0.12 | EEH ^{ZT} 1V151P | EEH ^{ZT} 1V151V | 500 |
| | 270 | 10.0 | 10.2 | 10.5 | G | 3500 | 2200 | 16 | 0.12 | EEH ^{ZT} 1V271P | EEH ^{ZT} 1V271V | 500 |
| 50 | 68 | 8.0 | 10.2 | 10.5 | F | 2700 | 1700 | 25 | 0.10 | EEH ^{ZT} 1H680P | EEH ^{ZT} 1H680V | 500 |
| | 100 | 10.0 | 10.2 | 10.5 | G | 2900 | 1800 | 23 | 0.10 | EEH ^{ZT} 1H101P | EEH ^{ZT} 1H101V | 500 |
| | 120 | 10.0 | 10.2 | 10.5 | G | 2900 | 1800 | 23 | 0.10 | EEH ^{ZT} 1H121P | EEH ^{ZT} 1H121V | 500 |
| 63 | 33 | 8.0 | 10.2 | 10.5 | F | 2400 | 1500 | 32 | 0.08 | EEH ^{ZT} 1J330P | EEH ^{ZT} 1J330V | 500 |
| | 47 | 8.0 | 10.2 | 10.5 | F | 2400 | 1500 | 32 | 0.08 | EEH ^{ZT} 1J470P | EEH ^{ZT} 1J470V | 500 |
| | 56 | 10.0 | 10.2 | 10.5 | G | 2800 | 1700 | 25 | 0.08 | EEH ^{ZT} 1J560P | EEH ^{ZT} 1J560V | 500 |
| | 68 | 10.0 | 10.2 | 10.5 | G | 2800 | 1700 | 25 | 0.08 | EEH ^{ZT} 1J680P | EEH ^{ZT} 1J680V | 500 |
| | 82 | 10.0 | 10.2 | 10.5 | G | 2800 | 1700 | 25 | 0.08 | EEH ^{ZT} 1J820P | EEH ^{ZT} 1J820V | 500 |

*1: Ripple current (100 kHz / +125 °C or 135 °C)

*2: ESR (100 kHz / +20 °C)

*3: tan δ (120 Hz / +20 °C)

- ◆ Please refer to the page of "Reflow profile" and "The taping dimensions".
- ◆ The dimensions of the vibration-proof products, please refer to the page of the mounting specification.

Frequency correction factor for ripple current

| Rated capacitance (C) | Frequency (f) | 100 Hz ≤ f < 200 Hz | 200 Hz ≤ f < 300 Hz | 300 Hz ≤ f < 500 Hz | 500 Hz ≤ f < 1 kHz |
|-----------------------|-------------------|---------------------|----------------------|-----------------------|---------------------|
| C < 47 μF | Correction factor | 0.10 | 0.10 | 0.15 | 0.20 |
| 47 μF ≤ C < 150 μF | | 0.15 | 0.20 | 0.25 | 0.30 |
| 150 μF ≤ C | | 0.15 | 0.25 | 0.25 | 0.30 |
| Rated capacitance (C) | Frequency (f) | 1 kHz ≤ f < 2 kHz | 2 kHz ≤ f < 3 kHz | 3 kHz ≤ f < 5 kHz | 5 kHz ≤ f < 10 kHz |
| C < 47 μF | Correction factor | 0.30 | 0.40 | 0.45 | 0.50 |
| 47 μF ≤ C < 150 μF | | 0.40 | 0.45 | 0.55 | 0.60 |
| 150 μF ≤ C | | 0.45 | 0.50 | 0.60 | 0.65 |
| Rated capacitance (C) | Frequency (f) | 10 kHz ≤ f < 15 kHz | 15 kHz ≤ f < 20 kHz | 20 kHz ≤ f < 30 kHz | 30 kHz ≤ f < 40 kHz |
| C < 47 μF | Correction factor | 0.60 | 0.65 | 0.70 | 0.75 |
| 47 μF ≤ C < 150 μF | | 0.70 | 0.75 | 0.80 | 0.80 |
| 150 μF ≤ C | | 0.75 | 0.80 | 0.85 | 0.85 |
| Rated capacitance (C) | Frequency (f) | 40 kHz ≤ f < 50 kHz | 50 kHz ≤ f < 100 kHz | 100 kHz ≤ f < 500 kHz | 500 kHz ≤ f |
| C < 47 μF | Correction factor | 0.80 | 0.85 | 1.00 | 1.05 |
| 47 μF ≤ C < 150 μF | | 0.85 | 0.90 | 1.00 | 1.00 |
| 150 μF ≤ C | | 0.85 | 0.90 | 1.00 | 1.00 |

Conductive Polymer Hybrid Aluminum Electrolytic Capacitors
Surface Mount Type

ZTU series High temperature lead-free reflow

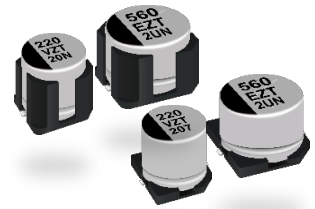

Features

- Endurance: 4000 h at 135 °C / 125 °C
- Higher ripple current (max 180 % of ZC series)
- Larger capacitance (max 170 % of ZT series)
- AEC-Q200 compliant
- RoHS compliant

Specifications

| Size code | F | G |
|------------------------------|--|----------------------------------|
| Category temp. range | -55 °C to +135 °C | |
| Rated voltage range | 25 V to 35 V | |
| Nominal capacitance range | 220 µF to 330 µF | 390 µF to 560 µF |
| Capacitance tolerance | ±20 % (120 Hz / +20 °C) | |
| Leakage current | I ≤ 0.01 CV (µA), 2 minutes after reaching rated voltage, 20 °C *CV = (Capacitance in µF) x (Rated voltage in V) | |
| Dissipation factor (tan δ) | Please see the attached characteristics list | |
| Surge voltage (V) | Rated voltage × 1.25 (15 °C to 35 °C) | |
| Endurance 1 | +125 °C ± 2 °C, 4000 h, apply the rated ripple current without exceeding the rated voltage | |
| | Capacitance change | Within ±30% of the initial value |
| | Dissipation factor (tan δ) | ≤ 200 % of the initial limit |
| | E.S.R. | ≤ 200 % of the initial limit |
| | Leakage current | Within the initial limit |
| Endurance 2 | +135 °C ± 2 °C, 4000 h, apply the rated ripple current without exceeding the rated voltage. | |
| | Capacitance change | Within ±30% of the initial value |
| | Dissipation factor (tan δ) | ≤ 200 % of the initial limit |
| | E.S.R. | ≤ 200 % of the initial limit |
| | Leakage current | Within the initial limit |
| Shelf life | After storage for 1000 hours at +135 °C ± 2 °C with no voltage applied and then being stabilized at +20 °C, capacitors shall meet the limits specified in endurance. (Capacitors are left at room temperature and humidity for 2 hours after the test. Then, apply the rated voltage for 30min with a series protection resistance of 1000 Ω ± 10 Ω. Measure electrical characteristics after discharging the capacitor.) | |
| | 85 °C ± 2 °C, 85 % to 90 %RH, 2000 h, rated voltage applied | |
| Damp heat (Load) | Capacitance change | |
| | Dissipation factor (tan δ) | |
| | E.S.R. | |
| | Leakage current | |
| Resistance to soldering heat | After reflow soldering and then being stabilized at +20 °C, capacitors shall meet the following limits. | |
| | Capacitance change | |
| | Dissipation factor (tan δ) | |
| | Leakage current | |

Marking

Example : 25 V 330 µF
Marking color : BLACK

| R. voltage code | Unit : V |
|-----------------|----------|
| E | 25 |
| V | 35 |

Dimensions (not to scale)

[Standard]

| Size code | øD | L | A, B | H max. | I | W | P | K |
|-----------|------|----------|------|--------|-----|----------|-----|----------|
| F | 8.0 | 10.2±0.3 | 8.3 | 10.0 | 3.4 | 0.90±0.2 | 3.1 | 0.70±0.2 |
| G | 10.0 | 10.2±0.3 | 10.3 | 12.0 | 3.5 | 0.90±0.2 | 4.6 | 0.70±0.2 |

[Vibration-proof product]

| Size code | øD | L | A, B | H max. | F | I | W | P | K | R | S | T |
|-----------|------|----------|------|--------|------------|-----|---------|-----|----------|----------|-----|---------|
| F | 8.0 | 10.5±0.3 | 8.3 | 10.0 | 0 to +0.15 | 3.4 | 1.2±0.2 | 3.1 | 0.70±0.2 | 0.70±0.2 | 5.3 | 1.3±0.2 |
| G | 10.0 | 10.5±0.3 | 10.3 | 12.0 | 0 to +0.15 | 3.5 | 1.2±0.2 | 4.6 | 0.70±0.2 | 0.70±0.2 | 6.9 | 1.3±0.2 |

Explanation of part numbers

◆ Part number system

e.g.: EEH^{ZT}1E³³¹U^P

| | | | | | | | | | | |
|---|-----------|------|-------------------|-------|------------------|------|----------------------|------|-----------------|------|
| EEH | ZT | | 1E | | 331 | | U | | P | |
| Product classification | Series | Code | Rated voltage (V) | Code* | Capacitance (μF) | Code | Dia øD | Code | Tape width (mm) | Code |
| | ZT | ZT | 25 | 1E | 220 | 221 | Miniaturized product | U | 16 to 24 | P |
| | | | 35 | 1V | 330 | 331 | | | | |
| | | | | | 390 | 391 | | | | |
| | | | | | 560 | 561 | | | | |
| Replace for the following configuration | | | | | | | | | | |
| Configuration | | Code | | | | | | | | |
| Vibration proof | | V | | | | | | | | |

*: If the total figures number of the part number exceeds 12 figures, "1" is omitted.

Characteristics list

Endurance 1 : 125 °C 4000 h

Endurance 2 : 135 °C 4000 h

| Rated voltage (V) | Capacitance (±20 %) (μF) | Case size (mm) | | | Size code | Specification | | | | Part number | | Min. packaging q'ty (pcs) |
|-------------------|--------------------------|----------------|----------|-----------------|-----------|---------------------------------------|------------------------|---------------------|------------------|--|--|---------------------------|
| | | øD | L | | | Ripple current* ¹ (mA rms) | ESR* ² (mΩ) | tan δ* ³ | Standard product | Vibration-proof product | | |
| | | | Standard | Vibration-proof | | | | | | | Endurance 1 (+125°C) | Endurance 2 (+135°C) |
| 25 | 330 | 8.0 | 10.2 | 10.5 | F | 2900 | 1800 | 22 | 0.14 | EEH ^{ZT} 1E ³³¹ UP | EEH ^{ZT} 1E ³³¹ UV | 500 |
| | 560 | 10.0 | 10.2 | 10.5 | G | 3500 | 2200 | 16 | 0.14 | EEH ^{ZT} 1E ⁵⁶¹ UP | EEH ^{ZT} 1E ⁵⁶¹ UV | 500 |
| 35 | 220 | 8.0 | 10.2 | 10.5 | F | 2900 | 1800 | 22 | 0.12 | EEH ^{ZT} 1V ²²¹ UP | EEH ^{ZT} 1V ²²¹ UV | 500 |
| | 390 | 10.0 | 10.2 | 10.5 | G | 3500 | 2200 | 16 | 0.12 | EEH ^{ZT} 1V ³⁹¹ UP | EEH ^{ZT} 1V ³⁹¹ UV | 500 |

*1: Ripple current (100 kHz / +125 °C or +135 °C)

*2: ESR (100 kHz / +20 °C)

*3: tan δ (120 Hz / +20 °C)

- ◆ Please refer to the page of "Reflow profile" and "The taping dimensions".
- ◆ The dimensions of the vibration-proof products, please refer to the page of the mounting specification.

Frequency correction factor for ripple current

| Rated capacitance (C) | Frequency (f) | | | |
|-----------------------|---------------------|---------------------|---------------------|--------------------|
| | 100 Hz ≤ f < 200 Hz | 200 Hz ≤ f < 300 Hz | 300 Hz ≤ f < 500 Hz | 500 Hz ≤ f < 1 kHz |
| 150 μF ≤ C | 0.15 | 0.25 | 0.25 | 0.30 |

| Rated capacitance (C) | Frequency (f) | | | |
|-----------------------|-------------------|-------------------|-------------------|--------------------|
| | 1 kHz ≤ f < 2 kHz | 2 kHz ≤ f < 3 kHz | 3 kHz ≤ f < 5 kHz | 5 kHz ≤ f < 10 kHz |
| 150 μF ≤ C | 0.45 | 0.50 | 0.60 | 0.65 |

| Rated capacitance (C) | Frequency (f) | | | |
|-----------------------|---------------------|---------------------|---------------------|---------------------|
| | 10 kHz ≤ f < 15 kHz | 15 kHz ≤ f < 20 kHz | 20 kHz ≤ f < 30 kHz | 30 kHz ≤ f < 40 kHz |
| 150 μF ≤ C | 0.75 | 0.80 | 0.85 | 0.85 |

| Rated capacitance (C) | Frequency (f) | | | |
|-----------------------|---------------------|----------------------|-----------------------|------------------------|
| | 40 kHz ≤ f < 50 kHz | 50 kHz ≤ f < 100 kHz | 100 kHz ≤ f < 500 kHz | 500 kHz ≤ f < 1000 kHz |
| 150 μF ≤ C | 0.85 | 0.90 | 1.00 | 1.00 |

Conductive Polymer Hybrid Aluminum Electrolytic Capacitors

Surface Mount Type

ZV series

High temperature lead-free reflow

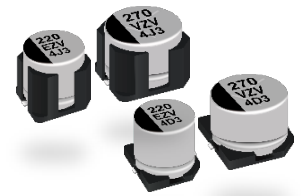

Features

- Endurance: 4000 h at 125 °C / 135 °C
- Low ESR (up to 39 %, Lower ESR than Current ZT series)
- Higher ripple current (max 150 % of ZT series)
- AEC-Q200 compliant
- RoHS compliant

Specifications

| Size code | F | G |
|------------------------------|--|---|
| Category temp. range | -55 °C to +135 °C | |
| Rated voltage range | 25 V to 63 V | |
| Nominal capacitance range | 33 µF to 220 µF | 56 µF to 330 µF |
| Capacitance tolerance | ±20 % (120 Hz / +20 °C) | |
| Leakage current | I ≤ 0.01 CV (µA), 2 minutes after reaching rated voltage, 20 °C *CV = (Capacitance in µF) x (Rated voltage in V) | |
| Dissipation factor (tan δ) | Please see the attached characteristics list | |
| Surge voltage (V) | Rated voltage × 1.25 (15 °C to 35 °C) | |
| Endurance 1 | +125 °C ± 2 °C, 4000 h, apply the rated ripple current without exceeding the rated voltage | |
| | Capacitance change | Within ±30% of the initial value |
| | Dissipation factor (tan δ) | ≤ 200 % of the initial limit |
| | E.S.R. | ≤ 200 % of the initial limit |
| | Leakage current | Within the initial limit |
| Endurance 2 | +135 °C ± 2 °C, 4000 h, apply the rated ripple current without exceeding the rated voltage | |
| | Capacitance change | Within ±30% of the initial value |
| | Dissipation factor (tan δ) | ≤ 200 % of the initial limit |
| | E.S.R. | ≤ 200 % of the initial limit |
| | Leakage current | Within the initial limit |
| Shelf life | After storage for 1000 hours at +135 °C ± 2 °C with no voltage applied and then being stabilized at +20 °C, capacitors shall meet the limits specified in endurance. (Capacitors are left at room temperature and humidity for 2 hours after the test. Then, apply the rated voltage for 30min with a series protection resistance of 1000 Ω ± 10 Ω. Measure electrical characteristics after discharging the capacitor.) | |
| | 85 °C ± 2 °C, 85 % to 90 %RH, 2000 h, rated voltage applied | |
| | Capacitance change | Within ±30% of the initial value |
| | Dissipation factor (tan δ) | ≤ 200 % of the initial limit |
| | E.S.R. | ≤ 200 % of the initial limit |
| Damp heat (Load) | After reflow soldering and then being stabilized at +20 °C, capacitors shall meet the following limits. | |
| | Capacitance change | Within ±10% of the initial value |
| | Dissipation factor (tan δ) | Within the initial limit |
| | Leakage current | Within the initial limit |
| | Resistance to soldering heat | After reflow soldering and then being stabilized at +20 °C, capacitors shall meet the following limits. |
| Resistance to soldering heat | Capacitance change | |
| | Dissipation factor (tan δ) | |
| | Leakage current | |

Marking

Example : 25 V 330 µF
Marking color : BLACK

Negative polarity marking (-)
Capacitance (µF)
Series identification
Lot number
Rated voltage code

| R. voltage code | Unit : V |
|-----------------|----------|
| E | 25 |
| V | 35 |
| H | 50 |
| J | 63 |

Dimensions (not to scale)

[Standard]

| Size code | øD | L | A, B | H max. | I | W | P | K |
|-----------|------|----------|------|--------|-----|----------|-----|----------|
| F | 8.0 | 10.2±0.3 | 8.3 | 10.0 | 3.4 | 0.90±0.2 | 3.1 | 0.70±0.2 |
| G | 10.0 | 10.2±0.3 | 10.3 | 12.0 | 3.5 | 0.90±0.2 | 4.6 | 0.70±0.2 |

[Vibration-proof product]

| Size code | øD | L | A, B | H max. | F | I | W | P | K | R | S | T |
|-----------|------|----------|------|--------|------------|-----|---------|-----|----------|----------|-----|---------|
| F | 8.0 | 10.5±0.3 | 8.3 | 10.0 | 0 to +0.15 | 3.4 | 1.2±0.2 | 3.1 | 0.70±0.2 | 0.70±0.2 | 5.3 | 1.3±0.2 |
| G | 10.0 | 10.5±0.3 | 10.3 | 12.0 | 0 to +0.15 | 3.5 | 1.2±0.2 | 4.6 | 0.70±0.2 | 0.70±0.2 | 6.9 | 1.3±0.2 |

Explanation of part numbers

◆ Part number system

e.g.: EEHZV1E221P

| | | | | | | | | | | |
|------------------------|-----------|------|-------------------|-------|------------------|------|------------------|------|---|------|
| EEH | ZV | | 1E | | 221 | | | | P | |
| Product classification | Series | Code | Rated voltage (V) | Code* | Capacitance (μF) | Code | Capacitance (μF) | Code | Tape width (mm) | Code |
| | ZV | ZV | 25 | 1E | 33 | 330 | 120 | 121 | 16 to 24 | P |
| | | | 35 | 1V | 47 | 470 | 150 | 151 | | |
| | | | 50 | 1H | 56 | 560 | 220 | 221 | | |
| | | | 63 | 1J | 68 | 680 | 270 | 271 | | |
| | | | | | 82 | 820 | 330 | 331 | | |
| | | | | | 100 | 101 | | | | |
| | | | | | | | | | Replace for the following configuration | |
| | | | | | | | | | Configuration | Code |
| | | | | | | | | | Vibration proof | V |

*: If the total figures number of the part number exceeds 12 figures, "1" is omitted.

Characteristics list

Endurance 1 : 125 °C 4000 h

Endurance 2 : 135 °C 4000 h

| Rated voltage (V) | Capacitance (±20 %) (μF) | Case size (mm) | | | Size code | Specification | | | | Part number | | Min. packaging qty (pcs) |
|-------------------|--------------------------|----------------|----------|-----------------|-----------|---------------------------|------------|---------|------------------|-------------------------|-------------|--------------------------|
| | | øD | L | | | Ripple current*1 (mA rms) | ESR*2 (mΩ) | tan δ*3 | Standard product | Vibration-proof product | Taping | |
| | | | Standard | Vibration-proof | | | | | | | | Endurance 1 (+125°C) |
| 25 | 220 | 8.0 | 10.2 | 10.5 | F | 3900 | 2900 | 16 | 0.14 | EEHZV1E221P | EEHZV1E221V | 500 |
| | 330 | 10.0 | 10.2 | 10.5 | G | 4600 | 3400 | 12 | 0.14 | EEHZV1E331P | EEHZV1E331V | 500 |
| 35 | 150 | 8.0 | 10.2 | 10.5 | F | 3900 | 2900 | 16 | 0.12 | EEHZV1V151P | EEHZV1V151V | 500 |
| | 270 | 10.0 | 10.2 | 10.5 | G | 4600 | 3400 | 12 | 0.12 | EEHZV1V271P | EEHZV1V271V | 500 |
| 50 | 68 | 8.0 | 10.2 | 10.5 | F | 3600 | 2500 | 19 | 0.10 | EEHZV1H680P | EEHZV1H680V | 500 |
| | 100 | 10.0 | 10.2 | 10.5 | G | 4300 | 3200 | 15 | 0.10 | EEHZV1H101P | EEHZV1H101V | 500 |
| | 120 | 10.0 | 10.2 | 10.5 | G | 4300 | 3200 | 15 | 0.10 | EEHZV1H121P | EEHZV1H121V | 500 |
| 63 | 33 | 8.0 | 10.2 | 10.5 | F | 3300 | 2300 | 22 | 0.08 | EEHZV1J330P | EEHZV1J330V | 500 |
| | 47 | 8.0 | 10.2 | 10.5 | F | 3300 | 2300 | 22 | 0.08 | EEHZV1J470P | EEHZV1J470V | 500 |
| | 56 | 10.0 | 10.2 | 10.5 | G | 4000 | 3000 | 17 | 0.08 | EEHZV1J560P | EEHZV1J560V | 500 |
| | 68 | 10.0 | 10.2 | 10.5 | G | 4000 | 3000 | 17 | 0.08 | EEHZV1J680P | EEHZV1J680V | 500 |
| | 82 | 10.0 | 10.2 | 10.5 | G | 4000 | 3000 | 17 | 0.08 | EEHZV1J820P | EEHZV1J820V | 500 |

*1: Ripple current (100 kHz / +125 °C or +135 °C)

*2: ESR (100 kHz / +20 °C)

*3: tan δ (120 Hz / +20 °C)

◆ Please refer to the page of "Reflow profile" and "The taping dimensions".

◆ The dimensions of the vibration-proof products, please refer to the page of the mounting specification.

Frequency correction factor for ripple current

| Rated capacitance (C) | Frequency (f) | 100 Hz ≤ f < 200 Hz | 200 Hz ≤ f < 300 Hz | 300 Hz ≤ f < 500 Hz | 500 Hz ≤ f < 1 kHz |
|-----------------------|-------------------|---------------------|----------------------|-----------------------|------------------------|
| C < 47 μF | Correction factor | 0.10 | 0.10 | 0.15 | 0.20 |
| 47 μF ≤ C < 150 μF | | 0.15 | 0.20 | 0.25 | 0.30 |
| 150 μF ≤ C | | 0.15 | 0.25 | 0.25 | 0.30 |
| Rated capacitance (C) | Frequency (f) | 1 kHz ≤ f < 2 kHz | 2 kHz ≤ f < 3 kHz | 3 kHz ≤ f < 5 kHz | 5 kHz ≤ f < 10 kHz |
| C < 47 μF | Correction factor | 0.30 | 0.40 | 0.45 | 0.50 |
| 47 μF ≤ C < 150 μF | | 0.40 | 0.45 | 0.55 | 0.60 |
| 150 μF ≤ C | | 0.45 | 0.50 | 0.60 | 0.65 |
| Rated capacitance (C) | Frequency (f) | 10 kHz ≤ f < 15 kHz | 15 kHz ≤ f < 20 kHz | 20 kHz ≤ f < 30 kHz | 30 kHz ≤ f < 40 kHz |
| C < 47 μF | Correction factor | 0.60 | 0.65 | 0.70 | 0.75 |
| 47 μF ≤ C < 150 μF | | 0.70 | 0.75 | 0.80 | 0.80 |
| 150 μF ≤ C | | 0.75 | 0.80 | 0.85 | 0.85 |
| Rated capacitance (C) | Frequency (f) | 40 kHz ≤ f < 50 kHz | 50 kHz ≤ f < 100 kHz | 100 kHz ≤ f < 500 kHz | 500 kHz ≤ f < 1000 kHz |
| C < 47 μF | Correction factor | 0.80 | 0.85 | 1.00 | 1.05 |
| 47 μF ≤ C < 150 μF | | 0.85 | 0.90 | 1.00 | 1.00 |
| 150 μF ≤ C | | 0.85 | 0.90 | 1.00 | 1.00 |

**Conductive Polymer Hybrid Aluminum
Electrolytic Capacitors**
Surface Mount Type

ZVU series High temperature lead-free reflow

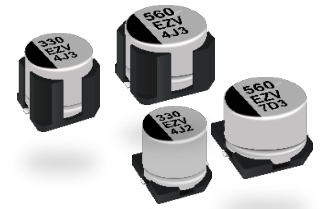

Features

- Endurance: 4000 h at 125 °C / 135 °C
- Larger capacitance (max 170 % of ZV series)
- Higher ripple current (max 150 % of ZT series)
- AEC-Q200 compliant
- RoHS compliant

Specifications

| Size code | F | G |
|------------------------------|--|----------------------------------|
| Category temp. range | -55 °C to +135 °C | |
| Rated voltage range | 25 V to 63 V | |
| Nominal capacitance range | 56 µF to 330 µF | 100 µF to 560 µF |
| Capacitance tolerance | ±20 % (120 Hz / +20 °C) | |
| Leakage current | $I \leq 0.01 CV$ (µA), 2 minutes after reaching rated voltage, 20 °C *CV = (Capacitance in µF) x (Rated voltage in V) | |
| Dissipation factor (tan δ) | Please see the attached characteristics list | |
| Surge voltage (V) | Rated voltage × 1.25 (15 °C to 35 °C) | |
| Endurance 1 | +125 °C ± 2 °C, 4000 h, apply the rated ripple current without exceeding the rated voltage | |
| | Capacitance change | Within ±30% of the initial value |
| | Dissipation factor (tan δ) | ≤ 200 % of the initial limit |
| | E.S.R. | ≤ 200 % of the initial limit |
| | Leakage current | Within the initial limit |
| Endurance 2 | +135 °C ± 2 °C, 4000 h, apply the rated ripple current without exceeding the rated voltage | |
| | Capacitance change | Within ±30% of the initial value |
| | Dissipation factor (tan δ) | ≤ 200 % of the initial limit |
| | E.S.R. | ≤ 200 % of the initial limit |
| | Leakage current | Within the initial limit |
| Shelf life | After storage for 1000 hours at +135 °C ± 2 °C with no voltage applied and then being stabilized at +20 °C, capacitors shall meet the limits specified in endurance. (Capacitors are left at room temperature and humidity for 2 hours after the test. Then, apply the rated voltage for 30min with a series protection resistance of 1000 Ω ± 10 Ω. Measure electrical characteristics after discharging the capacitor.) | |
| | 85 °C ± 2 °C, 85 % to 90 %RH, 2000 h, rated voltage applied | |
| Damp heat (Load) | Capacitance change | Within ±30% of the initial value |
| | Dissipation factor (tan δ) | ≤ 200 % of the initial limit |
| | E.S.R. | ≤ 200 % of the initial limit |
| | Leakage current | Within the initial limit |
| Resistance to soldering heat | After reflow soldering and then being stabilized at +20 °C, capacitors shall meet the following limits. | |
| | Capacitance change | Within ±10% of the initial value |
| | Dissipation factor (tan δ) | Within the initial limit |
| | Leakage current | Within the initial limit |

Marking

Example : 25 V 560 µF
Marking color : BLACK

Negative polarity marking (-)
Capacitance (µF)
Series identification
Lot number
Rated voltage code

| R. voltage code | Unit : V |
|-----------------|----------|
| E | 25 |
| V | 35 |
| H | 50 |
| J | 63 |

Dimensions (not to scale)

[Standard]

| Size code | øD | L | A, B | H max. | I | W | P | K |
|-----------|------|----------|------|--------|-----|----------|-----|----------|
| F | 8.0 | 10.2±0.3 | 8.3 | 10.0 | 3.4 | 0.90±0.2 | 3.1 | 0.70±0.2 |
| G | 10.0 | 10.2±0.3 | 10.3 | 12.0 | 3.5 | 0.90±0.2 | 4.6 | 0.70±0.2 |

[Vibration-proof product]

| Size code | øD | L | A, B | H max. | F | I | W | P | K | R | S | T |
|-----------|------|----------|------|--------|------------|-----|---------|-----|----------|----------|-----|---------|
| F | 8.0 | 10.5±0.3 | 8.3 | 10.0 | 0 to +0.15 | 3.4 | 1.2±0.2 | 3.1 | 0.70±0.2 | 0.70±0.2 | 5.3 | 1.3±0.2 |
| G | 10.0 | 10.5±0.3 | 10.3 | 12.0 | 0 to +0.15 | 3.5 | 1.2±0.2 | 4.6 | 0.70±0.2 | 0.70±0.2 | 6.9 | 1.3±0.2 |

Explanation of part numbers

◆ Part number system

e.g.: EEHZV1E331UP

| EEH | | ZV | | 1E | | 331 | | U | | P | | | | | |
|------------------------|--|--------|------|-------------------|--------|------------------|------|------------------|------|----------------------|------|---|------|--|--|
| Product classification | | Series | Code | Rated voltage (V) | Code * | Capacitance (μF) | Code | Capacitance (μF) | Code | Dia øD | Code | Tape width (mm) | Code | | |
| | | ZVU | ZV | 25 | 1E | 56 | 560 | 220 | 221 | Miniaturized product | U | 16 to 24 | P | | |
| | | | | 35 | 1V | 82 | 820 | 330 | 331 | | | | | | |
| | | | | 50 | 1H | 100 | 101 | 390 | 391 | | | | | | |
| | | | | 63 | 1J | 150 | 151 | 560 | 561 | | | | | | |
| | | | | | | | | | | | | Replace for the following configuration | | | |
| | | | | | | | | | | | | Configuration | Code | | |
| | | | | | | | | | | | | Vibration proof | V | | |

*: If the total figures number of the part number exceeds 12 figures, "1" is omitted.

Characteristics list

Endurance 1 : 125 °C 4000 h

Endurance 2 : 135 °C 4000 h

| Rated voltage (V) | Capacitance (±20 %) (μF) | Case size (mm) | | | Size code | Specification | | | | Part number | | Min. packaging q'ty (pcs) |
|-------------------|--------------------------|----------------|----------|-----------------|-----------|----------------------------|-------------|----------|------------------|-------------------------|--------------|---------------------------|
| | | øD | L | | | Ripple current *1 (mA rms) | ESR *2 (mΩ) | tan δ *3 | Standard product | Vibration-proof product | Taping | |
| | | | Standard | Vibration-proof | | | | | | | | Endurance 1 (+125°C) |
| 25 | 330 | 8.0 | 10.2 | 10.5 | F | 3900 | 2900 | 16 | 0.14 | EEHZV1E331UP | EEHZV1E331UV | 500 |
| | 560 | 10.0 | 10.2 | 10.5 | G | 4600 | 3400 | 12 | 0.14 | EEHZV1E561UP | EEHZV1E561UV | 500 |
| 35 | 220 | 8.0 | 10.2 | 10.5 | F | 3900 | 2900 | 16 | 0.12 | EEHZV1V221UP | EEHZV1V221UV | 500 |
| | 390 | 10.0 | 10.2 | 10.5 | G | 4600 | 3400 | 12 | 0.12 | EEHZV1V391UP | EEHZV1V391UV | 500 |
| 50 | 82 | 8.0 | 10.2 | 10.5 | F | 3600 | 2500 | 19 | 0.10 | EEHZV1H820UP | EEHZV1H820UV | 500 |
| | 150 | 10.0 | 10.2 | 10.5 | G | 4300 | 3200 | 15 | 0.10 | EEHZV1H151UP | EEHZV1H151UV | 500 |
| 63 | 56 | 8.0 | 10.2 | 10.5 | F | 3300 | 2300 | 22 | 0.08 | EEHZV1J560UP | EEHZV1J560UV | 500 |
| | 100 | 10.0 | 10.2 | 10.5 | G | 4000 | 3000 | 17 | 0.08 | EEHZV1J101UP | EEHZV1J101UV | 500 |

*1: Ripple current (100 kHz / +125 °C or +135 °C)

*2: ESR (100 kHz / +20 °C)

*3: tan δ (120 Hz / +20 °C)

◆ Please refer to the page of "Reflow profile" and "The taping dimensions".

◆ The dimensions of the vibration-proof products, please refer to the page of the mounting specification.

Frequency correction factor for ripple current

| Rated capacitance (C) | Frequency (f) | 100 Hz ≤ f < 200 Hz | 200 Hz ≤ f < 300 Hz | 300 Hz ≤ f < 500 Hz | 500 Hz ≤ f < 1 kHz |
|-----------------------|---------------|---------------------|----------------------|-----------------------|------------------------|
| 56 μF ≤ C < 150 μF | Correction | 0.15 | 0.20 | 0.25 | 0.30 |
| | factor | 0.15 | 0.25 | 0.25 | 0.30 |
| 150 μF ≤ C | | | | | |
| Rated capacitance (C) | Frequency (f) | 1 kHz ≤ f < 2 kHz | 2 kHz ≤ f < 3 kHz | 3 kHz ≤ f < 5 kHz | 5 kHz ≤ f < 10 kHz |
| 56 μF ≤ C < 150 μF | Correction | 0.40 | 0.45 | 0.55 | 0.60 |
| | factor | 0.45 | 0.50 | 0.60 | 0.65 |
| 150 μF ≤ C | | | | | |
| Rated capacitance (C) | Frequency (f) | 10 kHz ≤ f < 15 kHz | 15 kHz ≤ f < 20 kHz | 20 kHz ≤ f < 30 kHz | 30 kHz ≤ f < 40 kHz |
| 56 μF ≤ C < 150 μF | Correction | 0.70 | 0.75 | 0.80 | 0.80 |
| | factor | 0.75 | 0.80 | 0.85 | 0.85 |
| 150 μF ≤ C | | | | | |
| Rated capacitance (C) | Frequency (f) | 40 kHz ≤ f < 50 kHz | 50 kHz ≤ f < 100 kHz | 100 kHz ≤ f < 500 kHz | 500 kHz ≤ f < 1000 kHz |
| 56 μF ≤ C < 150 μF | Correction | 0.85 | 0.90 | 1.00 | 1.00 |
| | factor | 0.85 | 0.90 | 1.00 | 1.00 |
| 150 μF ≤ C | | | | | |

Conductive Polymer Hybrid Aluminum Electrolytic Capacitors
Surface Mount Type

ZS series

High temperature lead-free reflow

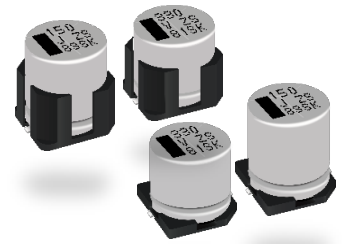

Features

- Endurance: 4000 h at 135 °C / 125 °C
- High ripple current and High capacitance
- High-withstand voltage (to 63 V)
- Vibration-proof product is available upon request.
- AEC-Q200 compliant
- RoHS compliant

Specifications

| Size code | G12 | G16 |
|------------------------------|---|----------------------------------|
| Category temp. range | -55 °C to +135 °C | |
| Rated voltage range | 25 V to 63 V | |
| Nominal capacitance range | 100 μF to 470 μF | 150 μF to 560 μF |
| Capacitance tolerance | ±20 % (120 Hz / +20 °C) | |
| Leakage current | $I \leq 0.01 CV$ (μA), 2 minutes after reaching rated voltage, 20 °C *CV = (Capacitance in μF) x (Rated voltage in V) | |
| Dissipation factor (tan δ) | Please see the attached characteristics list | |
| Surge voltage (V) | Rated voltage × 1.25 (15 °C to 35 °C) | |
| Endurance 1 | +125 °C ± 2 °C, 4000 h, apply the rated ripple current without exceeding the rated voltage. | |
| | Capacitance change | Within ±30% of the initial value |
| | Dissipation factor (tan δ) | ≤ 200 % of the initial limit |
| | E.S.R. | ≤ 200 % of the initial limit |
| Endurance 2 | +135 °C ± 2 °C, 4000 h, apply the rated ripple current without exceeding the rated voltage. | |
| | Capacitance change | Within ±30% of the initial value |
| | Dissipation factor (tan δ) | ≤ 200 % of the initial limit |
| | E.S.R. | ≤ 200 % of the initial limit |
| Shelf life | After storage for 1000 hours at +135 °C ± 2 °C with no voltage applied and then being stabilized at +20°C, stabilized at +20°C, capacitors shall meet the limits specified in endurance. (Capacitors are left at room temperature and humidity for 2 hours after the test. Then, apply the rated voltage for 30min with a series protection resistance of 1000 Ω ± 10 Ω. Measure electrical characteristics after discharging the capacitor.) | |
| Damp heat (Load) | +85 °C ± 2 °C, 85 % to 90 %RH, 2000 h, rated voltage applied. | |
| | Capacitance change | Within ±30% of the initial value |
| | Dissipation factor (tan δ) | ≤ 200 % of the initial limit |
| | E.S.R. | ≤ 200 % of the initial limit |
| Resistance to soldering heat | After reflow soldering and then being stabilized at +20°C, capacitors shall meet the following limits. | |
| | Capacitance change | Within ±10% of the initial value |
| | Dissipation factor (tan δ) | Within the initial limit |
| | Leakage current | Within the initial limit |

Marking

Example : 35 V 470 μF
Marking color : BLACK

Negative polarity marking (-)

Capacitance (μF)

Series identification

Rated voltage code

Lot number

R. voltage code Unit : V

| | |
|---|----|
| E | 25 |
| V | 35 |
| H | 50 |
| J | 63 |

Dimensions (not to scale)

[Standard]

Pressure relief (ø10 ≦)

() Reference size

| Size code | øD | L | A, B | H | I | W | P |
|-----------|------|------|------|----------|-----|---------|-----|
| G12 | 10.0 | 12.5 | 10.3 | 11.0±0.2 | 3.2 | 1.2±0.2 | 4.6 |
| G16 | 10.0 | 16.5 | 10.3 | 11.0±0.2 | 3.2 | 1.2±0.2 | 4.6 |

Unit : mm

[Vibration-proof product]

Pressure relief (ø10 ≦)

Supportive terminals

() Reference size

| Size code | øD | L | A, B | H | F | I | W | P | R | S | T |
|-----------|------|------|------|----------|------------|-----|---------|-----|----------|-----|---------|
| G12 | 10.0 | 12.8 | 10.3 | 11.0±0.2 | 0 to +0.15 | 3.2 | 1.2±0.2 | 4.6 | 0.70±0.2 | 6.9 | 1.3±0.2 |
| G16 | 10.0 | 16.8 | 10.3 | 11.0±0.2 | 0 to +0.15 | 3.2 | 1.2±0.2 | 4.6 | 0.70±0.2 | 6.9 | 1.3±0.2 |

Unit : mm

Explanation of part numbers

◆ Part number system

e.g.: EEH^{ZS}1E471P

| | | | | | | | | | | |
|------------------------|-----------|------|-------------------|-------|------------------|------|------------------|------|-----------------|------|
| EEH | ZS | | 1E | | 471 | | | | P | |
| Product classification | Series | Code | Rated voltage (V) | Code* | Capacitance (μF) | Code | Capacitance (μF) | Code | Tape width (mm) | Code |
| | ZS | ZS | 25 | 1E | 100 | 101 | 330 | 331 | 16 to 24 | P |
| | | | 35 | 1V | 150 | 151 | 470 | 471 | | |
| | | | 50 | 1H | 220 | 221 | 560 | 561 | | |
| | | | 63 | 1J | | | | | | |

| | |
|---|------|
| Replace for the following configuration | |
| Configuration | Code |
| Vibration proof | V |

*: If the total figures number of the part number exceeds 12 figures, "1" is omitted.

Characteristics list

Endurance 1 : 125 °C 4000 h

Endurance 2 : 135 °C 4000 h

| Rated voltage (V) | Capacitance (±20 %) (μF) | Case size (mm) | | | Size code | Specification | | | | Part number | | Min. packaging q'ty (pcs) |
|-------------------|--------------------------|----------------|----------|-----------------|-----------|---------------------------------------|------------------------|---------------------|------------------|--------------------------|--------------------------|---------------------------|
| | | øD | L | | | Ripple current ^{*1} (mA rms) | ESR ^{*2} (mΩ) | tan δ ^{*3} | Standard product | Vibration-proof product | | |
| | | | Standard | Vibration-proof | | | | | | | Endurance 1 (+125°C) | Endurance 2 (+135°C) |
| 25 | 470 | 10.0 | 12.5 | 12.8 | G12 | 3500 | 2500 | 14 | 0.14 | EEH ^{ZS} 1E471P | EEH ^{ZS} 1E471V | 400 |
| | 560 | 10.0 | 16.5 | 16.8 | G16 | 4000 | 2900 | 11 | 0.14 | EEH ^{ZS} 1E561P | EEH ^{ZS} 1E561V | 250 |
| 35 | 330 | 10.0 | 12.5 | 12.8 | G12 | 3500 | 2500 | 14 | 0.12 | EEH ^{ZS} 1V331P | EEH ^{ZS} 1V331V | 400 |
| | 470 | 10.0 | 16.5 | 16.8 | G16 | 4000 | 2900 | 11 | 0.12 | EEH ^{ZS} 1V471P | EEH ^{ZS} 1V471V | 250 |
| 50 | 150 | 10.0 | 12.5 | 12.8 | G12 | 3200 | 2250 | 17 | 0.10 | EEH ^{ZS} 1H151P | EEH ^{ZS} 1H151V | 400 |
| | 220 | 10.0 | 16.5 | 16.8 | G16 | 3700 | 2600 | 13 | 0.10 | EEH ^{ZS} 1H221P | EEH ^{ZS} 1H221V | 250 |
| 63 | 100 | 10.0 | 12.5 | 12.8 | G12 | 3000 | 2100 | 19 | 0.08 | EEH ^{ZS} 1J101P | EEH ^{ZS} 1J101V | 400 |
| | 150 | 10.0 | 16.5 | 16.8 | G16 | 3500 | 2400 | 15 | 0.08 | EEH ^{ZS} 1J151P | EEH ^{ZS} 1J151V | 250 |

*1: Ripple current (100 kHz / +125 °C or +135 °C)

*2: ESR (100 kHz / +20 °C)

*3: tan δ (120 Hz / +20 °C)

◆ Please refer to the page of "Reflow profile" and "The taping dimensions".

◆ The dimensions of the vibration-proof products, please refer to the page of the mounting specification.

Frequency correction factor for ripple current

| Rated capacitance (C) | Frequency (f) | 100 Hz ≤ f < 200 Hz | 200 Hz ≤ f < 300 Hz | 300 Hz ≤ f < 500 Hz | 500 Hz ≤ f < 1 kHz |
|-----------------------|-------------------|---------------------|---------------------|---------------------|--------------------|
| 100 μF ≤ C < 150 μF | Correction factor | 0.15 | 0.20 | 0.25 | 0.30 |
| | 150 μF ≤ C | 0.15 | 0.25 | 0.25 | 0.30 |

| Rated capacitance (C) | Frequency (f) | 1 kHz ≤ f < 2 kHz | 2 kHz ≤ f < 3 kHz | 3 kHz ≤ f < 5 kHz | 5 kHz ≤ f < 10 kHz |
|-----------------------|-------------------|-------------------|-------------------|-------------------|--------------------|
| 100 μF ≤ C < 150 μF | Correction factor | 0.40 | 0.45 | 0.55 | 0.60 |
| | 150 μF ≤ C | 0.45 | 0.50 | 0.60 | 0.65 |

| Rated capacitance (C) | Frequency (f) | 10 kHz ≤ f < 15 kHz | 15 kHz ≤ f < 20 kHz | 20 kHz ≤ f < 30 kHz | 30 kHz ≤ f < 40 kHz |
|-----------------------|-------------------|---------------------|---------------------|---------------------|---------------------|
| 100 μF ≤ C < 150 μF | Correction factor | 0.70 | 0.75 | 0.80 | 0.80 |
| | 150 μF ≤ C | 0.75 | 0.80 | 0.85 | 0.85 |

| Rated capacitance (C) | Frequency (f) | 40 kHz ≤ f < 50 kHz | 50 kHz ≤ f < 100 kHz | 100 kHz ≤ f < 500 kHz | 500 kHz ≤ f |
|-----------------------|-------------------|---------------------|----------------------|-----------------------|-------------|
| 100 μF ≤ C < 150 μF | Correction factor | 0.85 | 0.90 | 1.00 | 1.00 |
| | 150 μF ≤ C | 0.85 | 0.90 | 1.00 | 1.00 |

Conductive Polymer Hybrid Aluminum Electrolytic Capacitors
Surface Mount Type

ZSU series High temperature lead-free reflow

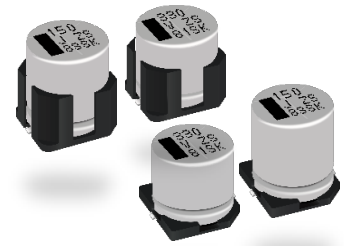

Features

- Endurance: 4000 h at 135 °C / 125 °C
- Large capacitance compared with ZS series
- Vibration-proof product is available upon request.
- AEC-Q200 compliant
- RoHS compliant

Specifications

| Size code | G12 | G16 |
|------------------------------|---|--|
| Category temp. range | -55 °C to +135 °C | |
| Rated voltage range | 25 V to 63 V | |
| Nominal capacitance range | 120 μF to 680 μF | 180 μF to 1000 μF |
| Capacitance tolerance | ±20 % (120 Hz / +20 °C) | |
| Leakage current | $I \leq 0.01 CV (\mu A)$, 2 minutes after reaching rated voltage, 20 °C *CV = (Capacitance in μF) x (Rated voltage in V) | |
| Dissipation factor (tan δ) | Please see the attached characteristics list | |
| Surge voltage (V) | Rated voltage × 1.25 (15 °C to 35 °C) | |
| Endurance 1 | +125 °C ± 2 °C, 4000 h, apply the rated ripple current without exceeding the rated voltage. | |
| | Capacitance change | Within ±30% of the initial value |
| | Dissipation factor (tan δ) | ≤ 200 % of the initial limit |
| | E.S.R. | ≤ 200 % of the initial limit |
| | Leakage current | Within the initial limit |
| Endurance 2 | +135 °C ± 2 °C, 4000 h, apply the rated ripple current without exceeding the rated voltage. | |
| | Capacitance change | Within ±30% of the initial value |
| | Dissipation factor (tan δ) | ≤ 200 % of the initial limit |
| | E.S.R. | ≤ 200 % of the initial limit |
| | Leakage current | Within the initial limit |
| Shelf life | After storage for 1000 hours at +135 °C ± 2 °C with no voltage applied and then being stabilized at +20°C, capacitors shall meet the limits specified in endurance. (Capacitors are left at room temperature and humidity for 2 hours after the test. Then, apply the rated voltage for 30min with a series protection resistance of 1000 Ω ± 10 Ω. Measure electrical characteristics after discharging the capacitor.) | |
| | +85 °C ± 2 °C, 85 % to 90 %RH, 2000 h, rated voltage applied. | |
| | Capacitance change | Within ±30% of the initial value |
| Damp heat (Load) | Dissipation factor (tan δ) | ≤ 200 % of the initial limit |
| | E.S.R. | ≤ 200 % of the initial limit |
| | Leakage current | Within the initial limit |
| | Resistance to soldering heat | After reflow soldering and then being stabilized at +20°C, capacitors shall meet the following limits. |
| Resistance to soldering heat | Capacitance change | Within ±10% of the initial value |
| | Dissipation factor (tan δ) | Within the initial limit |
| | Leakage current | Within the initial limit |

Marking

Example : 25 V 680 μF
Marking color : BLACK

Negative polarity marking (-)
Capacitance (μF)
Series identification
Rated voltage code
Lot number

| R. voltage code | Unit : V |
|-----------------|----------|
| E | 25 |
| V | 35 |
| H | 50 |
| J | 63 |

Dimensions (not to scale)

[Standard]

| Size code | øD | L | A, B | H | I | W | P |
|-----------|------|------|------|----------|-----|---------|-----|
| G12 | 10.0 | 12.5 | 10.3 | 11.0±0.2 | 3.2 | 1.2±0.2 | 4.6 |
| G16 | 10.0 | 16.5 | 10.3 | 11.0±0.2 | 3.2 | 1.2±0.2 | 4.6 |

[Vibration-proof product]

| Size code | øD | L | A, B | H | F | I | W | P | R | S | T |
|-----------|------|------|------|----------|------------|-----|---------|-----|----------|-----|---------|
| G12 | 10.0 | 12.8 | 10.3 | 11.0±0.2 | 0 to +0.15 | 3.2 | 1.2±0.2 | 4.6 | 0.70±0.2 | 6.9 | 1.3±0.2 |
| G16 | 10.0 | 16.8 | 10.3 | 11.0±0.2 | 0 to +0.15 | 3.2 | 1.2±0.2 | 4.6 | 0.70±0.2 | 6.9 | 1.3±0.2 |

Explanation of part numbers

◆ Part number system

e.g.: EEH^{ZS}1E681UP

| | | | | | | | | | | | | |
|---|-----------|------|-------------------|--------|------------------|------|------------------|------|----------------------|------|-----------------|------|
| EEH | ZS | | 1E | | 681 | | | | U | | P | |
| Product classification | Series | Code | Rated voltage (V) | Code * | Capacitance (μF) | Code | Capacitance (μF) | Code | Dia øD | Code | Tape width (mm) | Code |
| | ZS | ZS | 25 | 1E | 120 | 121 | 470 | 471 | Miniaturized product | U | 16 to 24 | P |
| | | | 35 | 1V | 180 | 181 | 680 | 681 | | | | |
| | | | 50 | 1H | 270 | 271 | 1000 | 102 | | | | |
| | | | 63 | 1J | | | | | | | | |
| Replace for the following configuration | | | | | | | | | | | | |
| | | | | | | | | | | | Configuration | Code |
| | | | | | | | | | | | Vibration proof | V |

*: If the total figures number of the part number exceeds 12 figures, "1" is omitted.

Characteristics list

Endurance 1 : 125 °C 4000 h

Endurance 2 : 135 °C 4000 h

| Rated voltage (V) | Capacitance (±20 %) (μF) | Case size (mm) | | | Size code | Specification | | | | Part number | | Min. packaging q'ty (pcs) |
|-------------------|--------------------------|----------------|----------|-----------------|-----------|---------------------------------------|------------------------|---------------------|------------------|---------------------------|---------------------------|---------------------------|
| | | øD | L | | | Ripple current ^{*1} (mA rms) | ESR ^{*2} (mΩ) | tan δ ^{*3} | Standard product | Vibration-proof product | | |
| | | | Standard | Vibration-proof | | | | | | | Endurance 1 125 °C | Endurance 2 135 °C |
| 25 | 680 | 10.0 | 12.5 | 12.8 | G12 | 3500 | 2500 | 14 | 0.14 | EEH ^{ZS} 1E681UP | EEH ^{ZS} 1E681UV | 400 |
| | 1000 | 10.0 | 16.5 | 16.8 | G16 | 4000 | 2900 | 11 | 0.14 | EEH ^{ZS} 1E102UP | EEH ^{ZS} 1E102UV | 250 |
| 35 | 470 | 10.0 | 12.5 | 12.8 | G12 | 3500 | 2500 | 14 | 0.12 | EEH ^{ZS} 1V471UP | EEH ^{ZS} 1V471UV | 400 |
| | 680 | 10.0 | 16.5 | 16.8 | G16 | 4000 | 2900 | 11 | 0.12 | EEH ^{ZS} 1V681UP | EEH ^{ZS} 1V681UV | 250 |
| 50 | 180 | 10.0 | 12.5 | 12.8 | G12 | 3200 | 2250 | 17 | 0.10 | EEH ^{ZS} 1H181UP | EEH ^{ZS} 1H181UV | 400 |
| | 270 | 10.0 | 16.5 | 16.8 | G16 | 3700 | 2600 | 13 | 0.10 | EEH ^{ZS} 1H271UP | EEH ^{ZS} 1H271UV | 250 |
| 63 | 120 | 10.0 | 12.5 | 12.8 | G12 | 3000 | 2100 | 19 | 0.08 | EEH ^{ZS} 1J121UP | EEH ^{ZS} 1J121UV | 400 |
| | 180 | 10.0 | 16.5 | 16.8 | G16 | 3500 | 2400 | 15 | 0.08 | EEH ^{ZS} 1J181UP | EEH ^{ZS} 1J181UV | 250 |

*1: Ripple current (100 kHz / +125 °C or 135 °C)

*2: ESR (100 kHz / +20 °C)

*3: tan δ (120 Hz / +20 °C)

◆ Please refer to the page of "Reflow profile" and "The taping dimensions".

◆ The dimensions of the vibration-proof products, please refer to the page of the mounting specification.

Frequency correction factor for ripple current

| Rated capacitance (C) | Frequency (f) | 100 Hz ≤ f < 120 Hz | 120 Hz ≤ f < 200 Hz | 200 Hz ≤ f < 300 Hz | 300 Hz ≤ f < 500 Hz |
|-----------------------|-------------------|---------------------|----------------------|-----------------------|------------------------|
| 120 μF ≤ C | Correction factor | 0.15 | 0.20 | 0.25 | 0.30 |
| Rated capacitance (C) | Frequency (f) | 500 Hz ≤ f < 1 kHz | 1 kHz ≤ f < 2 kHz | 2 kHz ≤ f < 3 kHz | 3 kHz ≤ f < 5 kHz |
| 120 μF ≤ C | Correction factor | 0.40 | 0.50 | 0.60 | 0.65 |
| Rated capacitance (C) | Frequency (f) | 5 kHz ≤ f < 10 kHz | 10 kHz ≤ f < 15 kHz | 15 kHz ≤ f < 20 kHz | 20 kHz ≤ f < 30 kHz |
| 120 μF ≤ C | Correction factor | 0.70 | 0.75 | 0.80 | 0.85 |
| Rated capacitance (C) | Frequency (f) | 30 kHz ≤ f < 50 kHz | 50 kHz ≤ f < 100 kHz | 100 kHz ≤ f < 500 kHz | 500 kHz ≤ f < 1000 kHz |
| 120 μF ≤ C | Correction factor | 0.85 | 0.90 | 1.00 | 1.00 |

**Conductive Polymer Hybrid Aluminum
Electrolytic Capacitors**
Surface Mount Type

ZU series

High temperature lead-free reflow

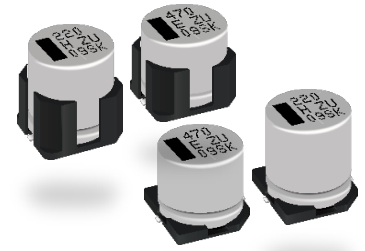

Features

- Endurance: 4000 h at 135 °C / 125 °C
- High ripple current compared with ZS series
- Vibration-proof product is available upon request.
- AEC-Q200 compliant
- RoHS compliant

Specifications

| Size code | G12 | G16 |
|------------------------------|--|----------------------------------|
| Category temp. range | -55 °C to +135 °C | |
| Rated voltage range | 25 V to 63 V | |
| Nominal capacitance range | 100 µF to 470 µF | 150 µF to 560 µF |
| Capacitance tolerance | ±20 % (120 Hz / +20 °C) | |
| Leakage current | I ≤ 0.01 CV (µA), 2 minutes after reaching rated voltage, 20 °C *CV = (Capacitance in µF) x (Rated voltage in V) | |
| Dissipation factor (tan δ) | Please see the attached characteristics list | |
| Surge voltage (V) | Rated voltage × 1.25 (15 °C to 35 °C) | |
| Endurance 1 | +125 °C ± 2 °C, 4000 h, apply the rated ripple current without exceeding the rated voltage | |
| | Capacitance change | Within ±30% of the initial value |
| | Dissipation factor (tan δ) | ≤ 200 % of the initial limit |
| | E.S.R. | ≤ 200 % of the initial limit |
| Endurance 2 | +135 °C ± 2 °C, 4000 h, apply the rated ripple current without exceeding the rated voltage | |
| | Capacitance change | Within ±30% of the initial value |
| | Dissipation factor (tan δ) | ≤ 200 % of the initial limit |
| | E.S.R. | ≤ 200 % of the initial limit |
| Shelf life | After storage for 1000 hours at +135 °C ± 2 °C with no voltage applied and then being stabilized at +20 °C, capacitors shall meet the limits specified in endurance. (Capacitors are left at room temperature and humidity for 2 hours after the test. Then, apply the rated voltage for 30min with a series protection resistance of 1000 Ω ± 10 Ω. Measure electrical characteristics after discharging the capacitor.) | |
| | 85 °C ± 2 °C, 85 % to 90 %RH, 2000 h, rated voltage applied | |
| Damp heat (Load) | Capacitance change | |
| | Within ±30% of the initial value | |
| | Dissipation factor (tan δ) | |
| | ≤ 200 % of the initial limit | |
| Resistance to soldering heat | E.S.R. | |
| | ≤ 200 % of the initial limit | |
| | Leakage current | |
| | Within the initial limit | |
| Resistance to soldering heat | After reflow soldering and then being stabilized at +20 °C, capacitors shall meet the following limits. | |
| | Capacitance change | |
| | Within ±10% of the initial value | |
| | Dissipation factor (tan δ) | |
| Within the initial limit | | |
| Leakage current | | |
| Within the initial limit | | |

Marking

Example : 25 V 470 µF
Marking color : BLACK

Negative polarity marking (-)

Capacitance (µF)

Series identification

Rated voltage code

Lot number

| R. voltage code | Unit : V |
|-----------------|----------|
| E | 25 |
| V | 35 |
| H | 50 |
| J | 63 |

Dimensions (not to scale)

[Standard]

| Size code | øD | L | A, B | H | I | W | P |
|-----------|------|------|------|----------|-----|---------|-----|
| G12 | 10.0 | 12.5 | 10.3 | 11.0±0.2 | 3.2 | 1.2±0.2 | 4.6 |
| G16 | 10.0 | 16.5 | 10.3 | 11.0±0.2 | 3.2 | 1.2±0.2 | 4.6 |

[Vibration-proof product]

| Size code | øD | L | A, B | H | F | I | W | P | R | S | T |
|-----------|------|------|------|----------|------------|-----|---------|-----|----------|-----|---------|
| G12 | 10.0 | 12.8 | 10.3 | 11.0±0.2 | 0 to +0.15 | 3.2 | 1.2±0.2 | 4.6 | 0.70±0.2 | 6.9 | 1.3±0.2 |
| G16 | 10.0 | 16.8 | 10.3 | 11.0±0.2 | 0 to +0.15 | 3.2 | 1.2±0.2 | 4.6 | 0.70±0.2 | 6.9 | 1.3±0.2 |

Explanation of part numbers

◆ Part number system

e.g.: EEHZU1E471P

| | | | | | | | | | | |
|------------------------|-----------|------|-------------------|--------|------------------|------|------------------|------|-----------------|------|
| EEH | ZU | | 1E | | 471 | | | | P | |
| Product classification | Series | Code | Rated voltage (V) | Code * | Capacitance (μF) | Code | Capacitance (μF) | Code | Tape width (mm) | Code |
| | ZU | ZU | 25 | 1E | 100 | 101 | 330 | 331 | 16 to 24 | P |
| | | | 35 | 1V | 150 | 151 | 470 | 471 | | |
| | | | 50 | 1H | 220 | 221 | 560 | 561 | | |
| | | | 63 | 1J | | | | | | |

| | |
|---|------|
| Replace for the following configuration | |
| Configuration | Code |
| Vibration proof | V |

*: If the total figures number of the part number exceeds 12 figures, "1" is omitted.

Characteristics list

Endurance 1 : 125 °C 4000 h

Endurance 2 : 135 °C 4000 h

| Rated voltage (V) | Capacitance (±20 %) (μF) | Case size (mm) | | | Size code | Specification | | | | Part number | | Min. packaging q'ty (pcs) |
|-------------------|--------------------------|----------------|----------|-----------------|-----------|----------------------------|-------------|----------|------------------|-------------------------|----------------------|---------------------------|
| | | øD | L | | | Ripple current *1 (mA rms) | ESR *2 (mΩ) | tan δ *3 | Standard product | Vibration-proof product | | |
| | | | Standard | Vibration-proof | | | | | | | Endurance 1 (+125°C) | Endurance 2 (+135°C) |
| 25 | 470 | 10.0 | 12.5 | 12.8 | G12 | 5000 | 3500 | 10 | 0.14 | EEHZU1E471P | EEHZU1E471V | 400 |
| | 560 | 10.0 | 16.5 | 16.8 | G16 | 5800 | 4000 | 8 | 0.14 | EEHZU1E561P | EEHZU1E561V | 250 |
| 35 | 330 | 10.0 | 12.5 | 12.8 | G12 | 4800 | 3300 | 11 | 0.12 | EEHZU1V331P | EEHZU1V331V | 400 |
| | 470 | 10.0 | 16.5 | 16.8 | G16 | 5500 | 3800 | 9 | 0.12 | EEHZU1V471P | EEHZU1V471V | 250 |
| 50 | 150 | 10.0 | 12.5 | 12.8 | G12 | 4600 | 3200 | 12 | 0.10 | EEHZU1H151P | EEHZU1H151V | 400 |
| | 220 | 10.0 | 16.5 | 16.8 | G16 | 5200 | 3600 | 10 | 0.10 | EEHZU1H221P | EEHZU1H221V | 250 |
| 63 | 100 | 10.0 | 12.5 | 12.8 | G12 | 4600 | 3200 | 12 | 0.08 | EEHZU1J101P | EEHZU1J101V | 400 |
| | 150 | 10.0 | 16.5 | 16.8 | G16 | 5200 | 3600 | 10 | 0.08 | EEHZU1J151P | EEHZU1J151V | 250 |

*1: Ripple current (100 kHz / +125 °C or +135 °C)

*2: ESR (100 kHz / +20 °C)

*3: tan δ (120 Hz / +20 °C)

◆ Please refer to the page of "Reflow profile" and "The taping dimensions".

◆ The dimensions of the vibration-proof products, please refer to the page of the mounting specification.

Frequency correction factor for ripple current

| Rated capacitance (C) | Frequency (f) | 100 Hz ≤ f < 200 Hz | 200 Hz ≤ f < 300 Hz | 300 Hz ≤ f < 500 Hz | 500 Hz ≤ f < 1 kHz |
|-----------------------|-------------------|---------------------|---------------------|---------------------|--------------------|
| 100 μF ≤ C < 150 μF | Correction factor | 0.15 | 0.20 | 0.25 | 0.30 |
| 150 μF ≤ C | | 0.15 | 0.25 | 0.25 | 0.30 |

| Rated capacitance (C) | Frequency (f) | 1 kHz ≤ f < 2 kHz | 2 kHz ≤ f < 3 kHz | 3 kHz ≤ f < 5 kHz | 5 kHz ≤ f < 10 kHz |
|-----------------------|-------------------|-------------------|-------------------|-------------------|--------------------|
| 100 μF ≤ C < 150 μF | Correction factor | 0.40 | 0.45 | 0.55 | 0.60 |
| 150 μF ≤ C | | 0.45 | 0.50 | 0.60 | 0.65 |

| Rated capacitance (C) | Frequency (f) | 10 kHz ≤ f < 15 kHz | 15 kHz ≤ f < 20 kHz | 20 kHz ≤ f < 30 kHz | 30 kHz ≤ f < 40 kHz |
|-----------------------|-------------------|---------------------|---------------------|---------------------|---------------------|
| 100 μF ≤ C < 150 μF | Correction factor | 0.70 | 0.75 | 0.80 | 0.80 |
| 150 μF ≤ C | | 0.75 | 0.80 | 0.85 | 0.85 |

| Rated capacitance (C) | Frequency (f) | 40 kHz ≤ f < 50 kHz | 50 kHz ≤ f < 100 kHz | 100 kHz ≤ f < 500 kHz | 500 kHz ≤ f |
|-----------------------|-------------------|---------------------|----------------------|-----------------------|-------------|
| 100 μF ≤ C < 150 μF | Correction factor | 0.85 | 0.90 | 1.00 | 1.00 |
| 150 μF ≤ C | | 0.85 | 0.90 | 1.00 | 1.00 |

After endurance ESR (100 kHz, -40°C)

| | | |
|-----------|-----|-----|
| Size code | G12 | G16 |
| ESR (Ω) | 0.3 | 0.3 |

**Conductive Polymer Hybrid Aluminum
Electrolytic Capacitors**
Surface Mount Type

ZUU series High temperature lead-free reflow



Features

- Endurance: 4000 h at 135 °C / 125 °C
- Higher ripple current (max 160 % of ZS series)
- Larger capacitance (max 180 % of ZU series)
- AEC-Q200 compliant
- RoHS compliant

Specifications

| Size code | G12 | | G16 | |
|---|--|----------------------------------|-------------------|--|
| Category temp. range | -55 °C to +135 °C | | | |
| Rated voltage range | 25 V to 63 V | | | |
| Nominal capacitance range | 120 µF to 680 µF | | 180 µF to 1000 µF | |
| Capacitance tolerance | ±20 % (120 Hz / +20 °C) | | | |
| Leakage current | I ≤ 0.01 CV (µA), 2 minutes after reaching rated voltage, 20 °C *CV = (Capacitance in µF) x (Rated voltage in V) | | | |
| Dissipation factor (tan δ) | Please see the attached characteristics list | | | |
| Surge voltage (V) | Rated voltage × 1.25 (15 °C to 35 °C) | | | |
| Endurance 1 | +125 °C ± 2 °C, 4000 h, apply the rated ripple current without exceeding the rated voltage | | | |
| | Capacitance change | Within ±30% of the initial value | | |
| | Dissipation factor (tan δ) | ≤ 200 % of the initial limit | | |
| | E.S.R. | ≤ 200 % of the initial limit | | |
| | Leakage current | Within the initial limit | | |
| ESR after endurance (Ω / 100 kHz)(-40 °C) | Size code | | | |
| | G12 | G16 | | |
| | 0.3 | 0.3 | | |
| Endurance 2 | +135 °C ± 2 °C, 4000 h, apply the rated ripple current without exceeding the rated voltage. | | | |
| | Capacitance change | Within ±30% of the initial value | | |
| | Dissipation factor (tan δ) | ≤ 200 % of the initial limit | | |
| | E.S.R. | ≤ 200 % of the initial limit | | |
| | Leakage current | Within the initial limit | | |
| ESR after endurance (Ω / 100 kHz)(-40 °C) | Size code | | | |
| | G12 | G16 | | |
| | 0.3 | 0.3 | | |
| Shelf life | After storage for 1000 hours at +135 °C ± 2 °C with no voltage applied and then being stabilized at +20 °C, capacitors shall meet the limits specified in endurance. (Capacitors are left at room temperature and humidity for 2 hours after the test. Then, apply the rated voltage for 30min with a series protection resistance of 1000 Ω ± 10 Ω. Measure electrical characteristics after discharging the capacitor.) | | | |
| Damp heat (Load) | 85 °C ± 2 °C, 85 % to 90 %RH, 2000 h, rated voltage applied | | | |
| | Capacitance change | Within ±30% of the initial value | | |
| | Dissipation factor (tan δ) | ≤ 200 % of the initial limit | | |
| | E.S.R. | ≤ 200 % of the initial limit | | |
| | Leakage current | Within the initial limit | | |
| Resistance to soldering heat | After reflow soldering and then being stabilized at +20 °C, capacitors shall meet the following limits. | | | |
| | Capacitance change | Within ±10% of the initial value | | |
| | Dissipation factor (tan δ) | Within the initial limit | | |
| | Leakage current | Within the initial limit | | |

Marking

Example : 35 V 470 µF
Marking color : BLACK

Negative polarity marking (-)
Capacitance (µF)
Series identification
Rated voltage code
Lot number

| | |
|-----------------|----------|
| R. voltage code | Unit : V |
| E 25 | H 50 |
| V 35 | J 63 |

Dimensions (not to scale)

[Standard]

| Size code | øD | L | A, B | H | I | W | P |
|-----------|------|------|------|----------|-----|---------|-----|
| G12 | 10.0 | 12.5 | 10.3 | 11.0±0.2 | 3.2 | 1.2±0.2 | 4.6 |
| G16 | 10.0 | 16.5 | 10.3 | 11.0±0.2 | 3.2 | 1.2±0.2 | 4.6 |

[Vibration-proof product]

| Size code | øD | L | A, B | H | F | I | W | P | R | S | T |
|-----------|------|------|------|----------|------------|-----|---------|-----|----------|-----|---------|
| G12 | 10.0 | 12.8 | 10.3 | 11.0±0.2 | 0 to +0.15 | 3.2 | 1.2±0.2 | 4.6 | 0.70±0.2 | 6.9 | 1.3±0.2 |
| G16 | 10.0 | 16.8 | 10.3 | 11.0±0.2 | 0 to +0.15 | 3.2 | 1.2±0.2 | 4.6 | 0.70±0.2 | 6.9 | 1.3±0.2 |

Explanation of part numbers

◆ Part number system

e.g.: EEHZU1E681UP

| | | | | | | | | | | |
|------------------------|-----------|------|-------------------|-------|------------------|------|----------------------|------|---|------|
| EEH | ZU | | 1E | | 681 | | U | | P | |
| Product classification | Series | Code | Rated voltage (V) | Code* | Capacitance (μF) | Code | Dia øD | Code | Tape width (mm) | Code |
| | ZU | ZU | 25 | 1E | 120 | 121 | Miniaturized product | U | 16 to 24 | P |
| | | | 35 | 1V | 180 | 181 | | | | |
| | | | 50 | 1H | 270 | 271 | | | | |
| | | | 63 | 1J | 470 | 471 | | | | |
| | | | | | 680 | 681 | | | | |
| | | | | | 1000 | 102 | | | | |
| | | | | | | | | | Replace for the following configuration | |
| | | | | | | | | | Configuration | Code |
| | | | | | | | | | Vibration proof | V |

*: If the total figures number of the part number exceeds 12 figures, "1" is omitted.

Characteristics list

Endurance 1 : 125 °C 4000 h

Endurance 2 : 135 °C 4000 h

| Rated voltage (V) | Capacitance (±20 %) (μF) | Case size (mm) | | | Size code | Specification | | | | Part number | | Min. packaging q'ty (pcs) |
|-------------------|--------------------------|----------------|----------|-----------------|-----------|---------------------------|------------|---------|------------------|-------------------------|----------------------|---------------------------|
| | | øD | L | | | Ripple current*1 (mA rms) | ESR*2 (mΩ) | tan δ*3 | Standard product | Vibration-proof product | | |
| | | | Standard | Vibration-proof | | | | | | | Endurance 1 (+125°C) | Endurance 2 (+135°C) |
| 25 | 680 | 10.0 | 12.5 | 12.8 | G12 | 5300 | 3700 | 10 | 0.14 | EEHZU1E681UP | EEHZU1E681UV | 400 |
| | 1000 | 10.0 | 16.5 | 16.8 | G16 | 6100 | 4300 | 8 | 0.14 | EEHZU1E102UP | EEHZU1E102UV | 250 |
| 35 | 470 | 10.0 | 12.5 | 12.8 | G12 | 5000 | 3500 | 11 | 0.12 | EEHZU1V471UP | EEHZU1V471UV | 400 |
| | 680 | 10.0 | 16.5 | 16.8 | G16 | 5800 | 4100 | 9 | 0.12 | EEHZU1V681UP | EEHZU1V681UV | 250 |
| 50 | 180 | 10.0 | 12.5 | 12.8 | G12 | 4800 | 3400 | 12 | 0.10 | EEHZU1H181UP | EEHZU1H181UV | 400 |
| | 270 | 10.0 | 16.5 | 16.8 | G16 | 5500 | 3800 | 10 | 0.10 | EEHZU1H271UP | EEHZU1H271UV | 250 |
| 63 | 120 | 10.0 | 12.5 | 12.8 | G12 | 4800 | 3400 | 12 | 0.08 | EEHZU1J121UP | EEHZU1J121UV | 400 |
| | 180 | 10.0 | 16.5 | 16.8 | G16 | 5500 | 3800 | 10 | 0.08 | EEHZU1J181UP | EEHZU1J181UV | 250 |

*1: Ripple current (100 kHz / +125 °C or +135 °C)

*2: ESR (100 kHz / +20 °C)

*3: tan δ (120 Hz / +20 °C)

◆ Please refer to the page of "Reflow profile" and "The taping dimensions".

◆ The dimensions of the vibration-proof products, please refer to the page of the mounting specification.

Frequency correction factor for ripple current

| Rated capacitance (C) | Frequency (f) | 100 Hz ≤ f < 200 Hz | 200 Hz ≤ f < 300 Hz | 300 Hz ≤ f < 500 Hz | 500 Hz ≤ f < 1 kHz |
|-----------------------|---------------|---------------------|----------------------|-----------------------|------------------------|
| 120 μF ≤ C < 150 μF | Correction | 0.15 | 0.20 | 0.25 | 0.30 |
| | factor | 0.15 | 0.25 | 0.25 | 0.30 |
| 150 μF ≤ C | | | | | |
| Rated capacitance (C) | Frequency (f) | 1 kHz ≤ f < 2 kHz | 2 kHz ≤ f < 3 kHz | 3 kHz ≤ f < 5 kHz | 5 kHz ≤ f < 10 kHz |
| 120 μF ≤ C < 150 μF | Correction | 0.40 | 0.45 | 0.55 | 0.60 |
| | factor | 0.45 | 0.50 | 0.60 | 0.65 |
| 150 μF ≤ C | | | | | |
| Rated capacitance (C) | Frequency (f) | 10 kHz ≤ f < 15 kHz | 15 kHz ≤ f < 20 kHz | 20 kHz ≤ f < 30 kHz | 30 kHz ≤ f < 40 kHz |
| 120 μF ≤ C < 150 μF | Correction | 0.70 | 0.75 | 0.80 | 0.80 |
| | factor | 0.75 | 0.80 | 0.85 | 0.85 |
| 150 μF ≤ C | | | | | |
| Rated capacitance (C) | Frequency (f) | 40 kHz ≤ f < 50 kHz | 50 kHz ≤ f < 100 kHz | 100 kHz ≤ f < 500 kHz | 500 kHz ≤ f < 1000 kHz |
| 120 μF ≤ C < 150 μF | Correction | 0.85 | 0.90 | 1.00 | 1.00 |
| | factor | 0.85 | 0.90 | 1.00 | 1.00 |
| 150 μF ≤ C | | | | | |

Conductive Polymer Hybrid Aluminum Electrolytic Capacitors

Surface Mount Type

ZE series

High temperature lead-free reflow

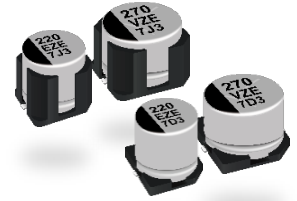

Features

- Endurance: 2000 h at 145 °C (High temperature / Long life)
- Low ESR and high ripple current
- High-withstand voltage (to 63 V)
- Characteristics dependencies in frequency and low temperature are as small as polymer type
- Vibration-proof product is available upon request
- AEC-Q200 compliant
- RoHS compliant

Specifications

| Size code | F | G |
|------------------------------|--|----------------------------------|
| Category temp. range | -55 °C to +145 °C | |
| Rated voltage range | 25 V to 63 V | |
| Nominal capacitance range | 33 µF to 220 µF | 56 µF to 330 µF |
| Capacitance tolerance | ±20 % (120 Hz / +20 °C) | |
| Leakage current | I ≤ 0.01 CV (µA), 2 minutes after reaching rated voltage, 20 °C *CV = (Capacitance in µF) x (Rated voltage in V) | |
| Dissipation factor (tan δ) | Please see the attached characteristics list | |
| Surge voltage (V) | Rated voltage × 1.25 (15 °C to 35 °C) | |
| Endurance 1 | +145 °C ± 2 °C, 2000 h, apply the rated ripple current without exceeding the rated voltage | |
| | Capacitance change | Within ±30% of the initial value |
| | Dissipation factor (tan δ) | ≤ 200 % of the initial limit |
| | E.S.R. | ≤ 200 % of the initial limit |
| Endurance 2 | +135 °C ± 2 °C, 4000 h, apply the rated ripple current without exceeding the rated voltage | |
| | Capacitance change | Within ±30% of the initial value |
| | Dissipation factor (tan δ) | ≤ 200 % of the initial limit |
| | E.S.R. | ≤ 200 % of the initial limit |
| Shelf life | After storage for 1000 hours at +145 °C ± 2 °C with no voltage applied and then being stabilized at +20 °C, capacitors shall meet the limits specified in endurance. (Capacitors are left at room temperature and humidity for 2 hours after the test. Then, apply the rated voltage for 30min with a series protection resistance of 1000 Ω ± 10 Ω. Measure electrical characteristics after discharging the capacitor.) | |
| | 85 °C ± 2 °C, 85 % to 90 %RH, 2000 h, rated voltage applied | |
| Damp heat (Load) | 85 °C ± 2 °C, 85 % to 90 %RH, 2000 h, rated voltage applied | |
| | Capacitance change | Within ±30% of the initial value |
| | Dissipation factor (tan δ) | ≤ 200 % of the initial limit |
| | E.S.R. | ≤ 200 % of the initial limit |
| Resistance to soldering heat | After reflow soldering and then being stabilized at +20 °C, capacitors shall meet the following limits. | |
| | Capacitance change | Within ±10% of the initial value |
| | Dissipation factor (tan δ) | Within the initial limit |
| | Leakage current | Within the initial limit |

Marking

Example : 25 V 220 µF
Marking color : BLACK

Negative polarity marking (-)

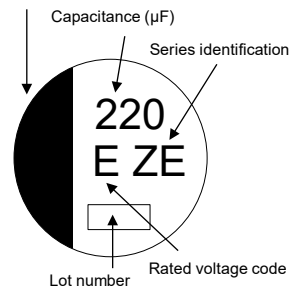

| R. voltage code | Unit : V |
|-----------------|----------|
| E | 25 |
| V | 35 |
| H | 50 |
| J | 63 |

Dimensions (not to scale)

[Standard]

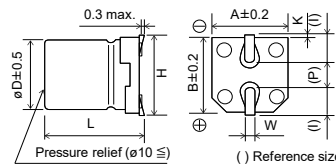

| Size code | øD | L | A, B | H _{max.} | I | W | P | K |
|-----------|------|----------|------|-------------------|-----|----------|-----|----------|
| F | 8.0 | 10.2±0.3 | 8.3 | 10 | 3.4 | 0.90±0.2 | 3.1 | 0.70±0.2 |
| G | 10.0 | 10.2±0.3 | 10.3 | 12.0 | 3.5 | 0.90±0.2 | 4.6 | 0.70±0.2 |

Unit : mm

[Vibration-proof product]

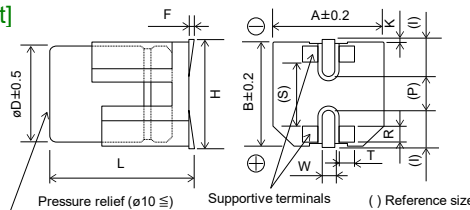

| Size code | øD | L | A, B | H _{max.} | F | I | W | P | K | R | S | T |
|-----------|------|----------|------|-------------------|------------|-----|---------|-----|----------|----------|-----|---------|
| F | 8.0 | 10.5±0.3 | 8.3 | 10.0 | 0 to +0.15 | 3.4 | 1.2±0.2 | 3.1 | 0.70±0.2 | 0.70±0.2 | 5.3 | 1.3±0.2 |
| G | 10.0 | 10.5±0.3 | 10.3 | 12.0 | 0 to +0.15 | 3.5 | 1.2±0.2 | 4.6 | 0.70±0.2 | 0.70±0.2 | 6.9 | 1.3±0.2 |

Unit : mm

Explanation of part numbers

◆ Part number system e.g.: EEHZE1E221P

| | | | | | | | | | | |
|------------------------|-----------|------|-------------------|-------|------------------|------|------------------|------|-----------------|------|
| EEH | ZE | | 1E | | 221 | | | | P | |
| Product classification | Series | Code | Rated voltage (V) | Code* | Capacitance (μF) | Code | Capacitance (μF) | Code | Tape width (mm) | Code |
| | ZE | ZE | 25 | 1E | 33 | 330 | 150 | 151 | 16 to 24 | P |
| | | | 35 | 1V | 56 | 560 | 220 | 221 | | |
| | | | 50 | 1H | 68 | 680 | 270 | 271 | | |
| | | | 63 | 1J | 82 | 820 | 330 | 331 | | |
| | | | | | 100 | 101 | | | | |

*: If the total figures number of the part number exceeds 12 figures, "1" is omitted.

| | |
|---|------|
| Replace for the following configuration | |
| Configuration | Code |
| Vibration proof | V |

Characteristics list

Endurance 1 : 145 °C 2000 h

Endurance 2 : 135 °C 4000 h

| Rated voltage (V) | Capacitance (±20 %) (μF) | Case size (mm) | | | Size code | Specification | | | | Part number | | Min. packaging q'ty (pcs) |
|-------------------|--------------------------|----------------|----------|-----------------|-----------|---------------------------------------|------------------------|---------------------|------------------|-------------------------|----------------------|---------------------------|
| | | øD | L | | | Ripple current* ¹ (mA rms) | ESR* ² (mΩ) | tan δ* ³ | Standard product | Vibration-proof product | | |
| | | | Standard | Vibration-proof | | | | | | | Endurance 1 (+145°C) | Endurance 2 (+135°C) |
| 25 | 220 | 8.0 | 10.2 | 10.5 | F | 700 | 1600 | 27 | 0.14 | EEHZE1E221P | EEHZE1E221V | 500 |
| | 330 | 10.0 | 10.2 | 10.5 | G | 900 | 2000 | 20 | 0.14 | EEHZE1E331P | EEHZE1E331V | 500 |
| 35 | 150 | 8.0 | 10.2 | 10.5 | F | 700 | 1600 | 27 | 0.12 | EEHZE1V151P | EEHZE1V151V | 500 |
| | 270 | 10.0 | 10.2 | 10.5 | G | 900 | 2000 | 20 | 0.12 | EEHZE1V271P | EEHZE1V271V | 500 |
| 50 | 68 | 8.0 | 10.2 | 10.5 | F | 600 | 1250 | 30 | 0.10 | EEHZE1H680P | EEHZE1H680V | 500 |
| | 100 | 10.0 | 10.2 | 10.5 | G | 800 | 1600 | 28 | 0.10 | EEHZE1H101P | EEHZE1H101V | 500 |
| 63 | 33 | 8.0 | 10.2 | 10.5 | F | 600 | 1100 | 40 | 0.08 | EEHZE1J330P | EEHZE1J330V | 500 |
| | 56 | 10.0 | 10.2 | 10.5 | G | 800 | 1400 | 30 | 0.08 | EEHZE1J560P | EEHZE1J560V | 500 |
| | 82 | 10.0 | 10.2 | 10.5 | G | 800 | 1400 | 30 | 0.08 | EEHZE1J820P | EEHZE1J820V | 500 |

*1: Ripple current (100 kHz / +145 °C or +135 °C) *2: ESR (100 kHz / +20 °C) *3: tan δ (120 Hz / +20 °C)

- ◆ Please refer to the page of "Reflow profile" and "The taping dimensions".
- ◆ The dimensions of the vibration-proof products, please refer to the page of the mounting specification.

Frequency correction factor for ripple current

| Rated capacitance (C) | Frequency (f) | 100 Hz ≤ f < 200 Hz | 200 Hz ≤ f < 300 Hz | 300 Hz ≤ f < 500 Hz | 500 Hz ≤ f < 1 kHz |
|-----------------------|-------------------|---------------------|---------------------|---------------------|--------------------|
| C < 47 μF | Correction factor | 0.10 | 0.10 | 0.15 | 0.20 |
| 47 μF ≤ C < 150 μF | | 0.15 | 0.20 | 0.25 | 0.30 |
| 150 μF ≤ C | | 0.15 | 0.25 | 0.25 | 0.30 |

| Rated capacitance (C) | Frequency (f) | 1 kHz ≤ f < 2 kHz | 2 kHz ≤ f < 3 kHz | 3 kHz ≤ f < 5 kHz | 5 kHz ≤ f < 10 kHz |
|-----------------------|-------------------|-------------------|-------------------|-------------------|--------------------|
| C < 47 μF | Correction factor | 0.30 | 0.40 | 0.45 | 0.50 |
| 47 μF ≤ C < 150 μF | | 0.40 | 0.45 | 0.55 | 0.60 |
| 150 μF ≤ C | | 0.45 | 0.50 | 0.60 | 0.65 |

| Rated capacitance (C) | Frequency (f) | 10 kHz ≤ f < 15 kHz | 15 kHz ≤ f < 20 kHz | 20 kHz ≤ f < 30 kHz | 30 kHz ≤ f < 40 kHz |
|-----------------------|-------------------|---------------------|---------------------|---------------------|---------------------|
| C < 47 μF | Correction factor | 0.60 | 0.65 | 0.70 | 0.75 |
| 47 μF ≤ C < 150 μF | | 0.70 | 0.75 | 0.80 | 0.80 |
| 150 μF ≤ C | | 0.75 | 0.80 | 0.85 | 0.85 |

| Rated capacitance (C) | Frequency (f) | 40 kHz ≤ f < 50 kHz | 50 kHz ≤ f < 100 kHz | 100 kHz ≤ f < 500 kHz | 500 kHz ≤ f |
|-----------------------|-------------------|---------------------|----------------------|-----------------------|-------------|
| C < 47 μF | Correction factor | 0.80 | 0.85 | 1.00 | 1.05 |
| 47 μF ≤ C < 150 μF | | 0.85 | 0.90 | 1.00 | 1.00 |
| 150 μF ≤ C | | 0.85 | 0.90 | 1.00 | 1.00 |

After endurance ESR (100 kHz, -40°C)

| Size code | F | G |
|-----------|-----|-----|
| ESR (Ω) | 0.4 | 0.3 |

Conductive Polymer Hybrid Aluminum Electrolytic Capacitors

Surface Mount Type

ZF series

High temperature lead-free reflow

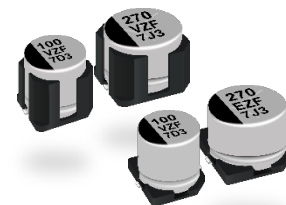

Features

- Endurance : 1000 h at 150 °C (High temperature)
- Low ESR and high ripple current
- High-withstand voltage (to 63 V)
- Vibration-proof product is available upon request
- AEC-Q200 compliant
- RoHS compliant

Specifications

| Size code | F | G |
|---|--|----------------------------------|
| Category temp. range | -55 °C to +150 °C | |
| Rated voltage range | 25 V to 63 V | |
| Nominal capacitance range | 33 µF to 150 µF | 56 µF to 270 µF |
| Capacitance tolerance | ±20 % (120 Hz / +20°C) | |
| Leakage current | $I \leq 0.01 CV (\mu A)$, 2 minutes after reaching rated voltage, 20 °C *CV = (Capacitance in µF) x (Rated voltage in V) | |
| Dissipation factor (tan δ) | Please see the attached characteristics list | |
| Surge voltage (V) | Rated voltage × 1.25 (15 °C to 35 °C) | |
| Endurance | +150 °C ± 2 °C, 1000 h, apply the rated ripple current without exceeding the rated voltage. | |
| | Capacitance change | Within ±30% of the initial value |
| | Dissipation factor (tan δ) | ≤ 200 % of the initial limit |
| | ESR | ≤ 200 % of the initial limit |
| | Leakage current | Within the initial limit |
| ESR after endurance (Ω / 100 kHz)(-40 °C) | Size code | |
| | F | G |
| | 0.4 | 0.3 |
| Shelf life | After storage for 1000 hours at +150 °C ± 2 °C with no voltage applied and then being stabilized at +20 °C, capacitors shall meet the limits specified in endurance. | |
| | (Capacitors are left at room temperature and humidity for 2 hours after the test. Then, apply the rated voltage for 30min with a series protection resistance of 1000 Ω ± 10 Ω. Measure electrical characteristics after discharging the capacitor.) | |
| Damp heat (Load) | +85 °C ± 2 °C, 85 % to 90 %RH, 2000 h, rated voltage applied | |
| | Capacitance change | Within ±30% of the initial value |
| | Dissipation factor (tan δ) | ≤ 200 % of the initial limit |
| | ESR | ≤ 200 % of the initial limit |
| | Leakage current | Within the initial limit |
| Resistance to soldering heat | After reflow soldering and then being stabilized at +20 °C, capacitors shall meet the following limits. | |
| | Capacitance change | Within ±10% of the initial value |
| | Dissipation factor (tan δ) | Within the initial limit |
| | Leakage current | Within the initial limit |

Marking

Example : 25 V 150 µF
Marking color : BLACK

Negative polarity marking (-)

Capacitance (µF)

Series identification

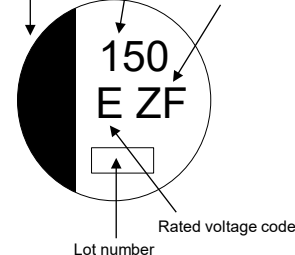

Rated voltage code

Lot number

| R. voltage code | Unit : V |
|-----------------|----------|
| E | 25 |
| V | 35 |
| H | 50 |
| J | 63 |

Dimensions (not to scale)

[Standard]

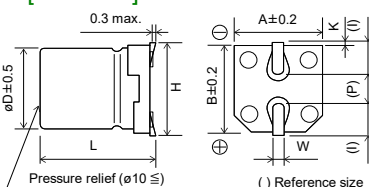

| Size code | øD | L | A, B | H _{max} | I | W | P | K |
|-----------|------|----------|------|------------------|-----|----------|-----|----------|
| F | 8.0 | 10.2±0.3 | 8.3 | 10 | 3.4 | 0.90±0.2 | 3.1 | 0.70±0.2 |
| G | 10.0 | 10.2±0.3 | 10.3 | 12.0 | 3.5 | 0.90±0.2 | 4.6 | 0.70±0.2 |

[Vibration-proof product]

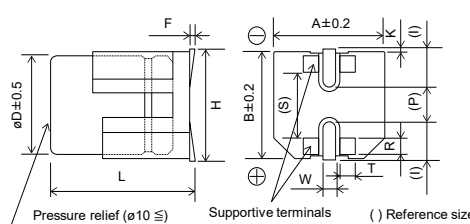

| Size code | øD | L | A, B | H _{max} | F | I | W | P | K | R | S | T |
|-----------|------|----------|------|------------------|------------|-----|---------|-----|----------|----------|-----|---------|
| F | 8.0 | 10.5±0.3 | 8.3 | 10.0 | 0 to +0.15 | 3.4 | 1.2±0.2 | 3.1 | 0.70±0.2 | 0.70±0.2 | 5.3 | 1.3±0.2 |
| G | 10.0 | 10.5±0.3 | 10.3 | 12.0 | 0 to +0.15 | 3.5 | 1.2±0.2 | 4.6 | 0.70±0.2 | 0.70±0.2 | 6.9 | 1.3±0.2 |

Explanation of part numbers

◆ Part number system e.g.: EEHZF1E151P

| EEH | ZF | | 1E | | 151 | | | | P | |
|------------------------|--------|------|-------------------|-------|------------------|------|------------------|------|-----------------|------|
| Product classification | Series | Code | Rated voltage (V) | Code* | Capacitance (μF) | Code | Capacitance (μF) | Code | Tape width (mm) | Code |
| | ZF | ZF | 25 | 1E | 33 | 330 | 150 | 151 | 16 to 24 | P |
| | | | 35 | 1V | 56 | 560 | 270 | 271 | | |
| | | | 50 | 1H | 100 | 101 | | | | |
| | | | 63 | 1J | | | | | | |

*: If the total figures number of the part number exceeds 12 figures, "1" is omitted.

| Replace for the following configuration | |
|---|------|
| Configuration | Code |
| Vibration proof | V |

Characteristics list

Endurance : 150 °C 1000 h

| Rated voltage (V) | Capacitance (±20 %) (μF) | Case size (mm) | | | Size code | Specification | | | Part number | | Min. packaging q'ty (pcs) |
|-------------------|--------------------------|----------------|----------|-----------------|-----------|---------------------------------------|------------------------|---------------------|------------------|-------------------------|---------------------------|
| | | øD | L | | | Ripple current* ¹ (mA rms) | ESR* ² (mΩ) | tan δ* ³ | Standard product | Vibration-proof product | Taping |
| | | | Standard | Vibration-proof | | | | | | | |
| 25 | 150 | 8.0 | 10.2 | 10.5 | F | 800 | 27 | 0.14 | EEHZF1E151P | EEHZF1E151V | 500 |
| | 270 | 10.0 | 10.2 | 10.5 | G | 1000 | 20 | 0.14 | EEHZF1E271P | EEHZF1E271V | 500 |
| 35 | 100 | 8.0 | 10.2 | 10.5 | F | 770 | 30 | 0.12 | EEHZF1V101P | EEHZF1V101V | 500 |
| | 150 | 10.0 | 10.2 | 10.5 | G | 950 | 23 | 0.12 | EEHZF1V151P | EEHZF1V151V | 500 |
| 50 | 56 | 8.0 | 10.2 | 10.5 | F | 700 | 35 | 0.10 | EEHZF1H560P | EEHZF1H560V | 500 |
| | 100 | 10.0 | 10.2 | 10.5 | G | 900 | 28 | 0.10 | EEHZF1H101P | EEHZF1H101V | 500 |
| 63 | 33 | 8.0 | 10.2 | 10.5 | F | 650 | 40 | 0.08 | EEHZF1J330P | EEHZF1J330V | 500 |
| | 56 | 10.0 | 10.2 | 10.5 | G | 840 | 30 | 0.08 | EEHZF1J560P | EEHZF1J560V | 500 |

*1: Ripple current (100 kHz / +150 °C)

*2: ESR (100 kHz / +20 °C)

*3: tan δ (120 Hz / +20 °C)

◆ Please refer to the page of "Reflow profile" and "The taping dimensions".

◆ The dimensions of the vibration-proof products, please refer to the page of the mounting specification.

Frequency correction factor for ripple current

| Rated capacitance (C) | Frequency (f) | 100 Hz ≤ f < 200 Hz | 200 Hz ≤ f < 300 Hz | 300 Hz ≤ f < 500 Hz | 500 Hz ≤ f < 1 kHz |
|-----------------------|-------------------|---------------------|---------------------|---------------------|--------------------|
| C < 47 μF | Correction factor | 0.10 | 0.10 | 0.15 | 0.20 |
| 47 μF ≤ C < 150 μF | | 0.15 | 0.20 | 0.25 | 0.30 |
| 150 μF ≤ C | | 0.15 | 0.25 | 0.25 | 0.30 |

| Rated capacitance (C) | Frequency (f) | 1 kHz ≤ f < 2 kHz | 2 kHz ≤ f < 3 kHz | 3 kHz ≤ f < 5 kHz | 5 kHz ≤ f < 10 kHz |
|-----------------------|-------------------|-------------------|-------------------|-------------------|--------------------|
| C < 47 μF | Correction factor | 0.30 | 0.40 | 0.45 | 0.50 |
| 47 μF ≤ C < 150 μF | | 0.40 | 0.45 | 0.55 | 0.60 |
| 150 μF ≤ C | | 0.45 | 0.50 | 0.60 | 0.65 |

| Rated capacitance (C) | Frequency (f) | 10 kHz ≤ f < 15 kHz | 15 kHz ≤ f < 20 kHz | 20 kHz ≤ f < 30 kHz | 30 kHz ≤ f < 40 kHz |
|-----------------------|-------------------|---------------------|---------------------|---------------------|---------------------|
| C < 47 μF | Correction factor | 0.60 | 0.65 | 0.70 | 0.75 |
| 47 μF ≤ C < 150 μF | | 0.70 | 0.75 | 0.80 | 0.80 |
| 150 μF ≤ C | | 0.75 | 0.80 | 0.85 | 0.85 |

| Rated capacitance (C) | Frequency (f) | 40 kHz ≤ f < 50 kHz | 50 kHz ≤ f < 100 kHz | 100 kHz ≤ f < 500 kHz | 500 kHz ≤ f |
|-----------------------|-------------------|---------------------|----------------------|-----------------------|-------------|
| C < 47 μF | Correction factor | 0.80 | 0.85 | 1.00 | 1.05 |
| 47 μF ≤ C < 150 μF | | 0.85 | 0.90 | 1.00 | 1.00 |
| 150 μF ≤ C | | 0.85 | 0.90 | 1.00 | 1.00 |

**Conductive Polymer Hybrid Aluminum
Electrolytic Capacitors**
Radial Lead Type
ZA-A series

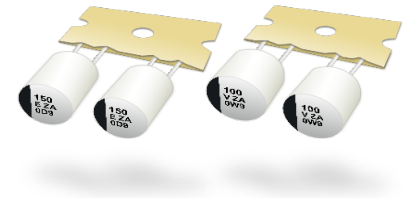

Features

- Endurance : 10000 h at 105 °C (105 °C standard product)
- Taping products for automatic insertion
- AEC-Q200 compliant
- RoHS compliant

Specifications

| | | | | |
|--|--|----------------------------------|-----------------|--|
| Size code | F | | G | |
| Category temp. range | -55 °C to +105 °C | | | |
| Rated voltage range | 25 V to 80 V | | | |
| Nominal capacitance range | 22 µF to 220 µF | | 33 µF to 330 µF | |
| Capacitance tolerance | ±20 % (120 Hz / +20°C) | | | |
| Leakage current | $I \leq 0.01 CV$ (µA), 2 minutes after reaching rated voltage, 20 °C *CV = (Capacitance in µF) x (Rated voltage in V) | | | |
| Dissipation factor (tan δ) | Please see the attached characteristics list | | | |
| Surge voltage (V) | Rated voltage × 1.25 (15 °C to 35 °C) | | | |
| Endurance | +105 °C ± 2 °C, 10000 h, apply the rated ripple current without exceeding the rated voltage. | | | |
| | Capacitance change | Within ±30% of the initial value | | |
| | Dissipation factor (tan δ) | ≤ 200 % of the initial limit | | |
| | ESR | ≤ 200 % of the initial limit | | |
| | Leakage current | Within the initial limit | | |
| ESR after endurance (Ω / 100 kHz)(-40 °C) | Size code | | | |
| | F | G | | |
| | 0.4 | 0.3 | | |
| Shelf life | After storage for 1000 hours at +105 °C ± 2 °C with no voltage applied and then being stabilized at +20 °C, capacitors shall meet the limits specified in endurance. (Capacitors are left at room temperature and humidity for 2 hours after the test. Then, apply the rated voltage for 30min with a series protection resistance of 1000 Ω ± 10 Ω. Measure electrical characteristics after discharging the capacitor.) | | | |
| Damp heat (Load) | +85 °C ± 2 °C, 85 % to 90 %RH, 2000 h, rated voltage applied | | | |
| | Capacitance change | Within ±30% of the initial value | | |
| | Dissipation factor (tan δ) | ≤ 200 % of the initial limit | | |
| | ESR | ≤ 200 % of the initial limit | | |
| | Leakage current | Within the initial limit | | |
| Resistance to soldering heat | After flow soldering and then being stabilized at +20 °C, capacitors shall meet the following limits. | | | |
| | Capacitance change | Within ±10% of the initial value | | |
| | Dissipation factor (tan δ) | Within the initial limit | | |
| | Leakage current | Within the initial limit | | |

Marking

Example : 25 V 150 µF
Marking color : BLACK

Negative polarity marking (-)

Capacitance (µF)

Series identification

Rated voltage code

Lot number

| R.voltage code | Unit : V |
|----------------|----------|
| E | 25 |
| V | 35 |
| H | 50 |
| J | 63 |
| K | 80 |

Dimensions (not to scale)

| Size code | øD | L | ød | F | P1 |
|-----------|------|-----|-----|-------------------------------------|-----------|
| F | 8.0 | 9.5 | 0.6 | 3.5±0.5 | 4.60±0.50 |
| G | 10.0 | 9.5 | 0.6 | 5.0 ^{+0.8} _{-0.2} | 3.85±0.50 |

Unit : mm

Explanation of part numbers

◆ Part number system e.g.: EEHAZA1E151B

| | | | | | | | | | | |
|------------------------|-----------|------|-------------------|-------|------------------|------|------------------|------|-----------------|------|
| EEHA | ZA | | 1E | | 151 | | | | B | |
| Product classification | Series | Code | Rated voltage (V) | Code* | Capacitance (μF) | Code | Capacitance (μF) | Code | Lead space (mm) | Code |
| | ZA | ZA | 25 | 1E | 22 | 220 | 82 | 820 | 3.5, 5.0 | B |
| | | | 35 | 1V | 33 | 330 | 100 | 101 | | |
| | | | 50 | 1H | 47 | 470 | 150 | 151 | | |
| | | | 63 | 1J | 56 | 560 | 220 | 221 | | |
| | | | 80 | 1K | 68 | 680 | 330 | 331 | | |

*: If the total figures number of the part number exceeds 12 figures, "1" is omitted.

Characteristics list

Endurance : 105 °C 10000 h

| Rated voltage (V) | Capacitance (±20 %) (μF) | Case size (mm) | | | Size code | Specification | | | Part number | Min. packaging q'ty (pcs) |
|-------------------|--------------------------|----------------|-----|-----|-----------|----------------------------|------------|---------|--------------|---------------------------|
| | | øD | L | ød | | Ripple current *1 (mA rms) | ESR*2 (mΩ) | tan δ*3 | | Taping |
| 25 | 150 | 8.0 | 9.5 | 0.6 | F | 2300 | 27 | 0.14 | EEHAZA1E151B | 1000 |
| | 220 | 8.0 | 9.5 | 0.6 | F | 2300 | 27 | 0.14 | EEHAZA1E221B | 1000 |
| | 330 | 10.0 | 9.5 | 0.6 | G | 2500 | 20 | 0.14 | EEHAZA1E331B | 500 |
| 35 | 100 | 8.0 | 9.5 | 0.6 | F | 2300 | 27 | 0.12 | EEHAZA1V101B | 1000 |
| | 150 | 8.0 | 9.5 | 0.6 | F | 2300 | 27 | 0.12 | EEHAZA1V151B | 1000 |
| | 220 | 10.0 | 9.5 | 0.6 | G | 2500 | 20 | 0.12 | EEHAZA1V221B | 500 |
| 50 | 270 | 10.0 | 9.5 | 0.6 | G | 2500 | 20 | 0.12 | EEHAZA1V271B | 500 |
| | 47 | 8.0 | 9.5 | 0.6 | F | 1800 | 30 | 0.10 | EEHAZA1H470B | 1000 |
| | 68 | 8.0 | 9.5 | 0.6 | F | 1800 | 30 | 0.10 | EEHAZA1H680B | 1000 |
| 63 | 100 | 10.0 | 9.5 | 0.6 | G | 2000 | 28 | 0.10 | EEHAZA1H101B | 500 |
| | 33 | 8.0 | 9.5 | 0.6 | F | 1700 | 40 | 0.08 | EEHAZA1J330B | 1000 |
| | 47 | 8.0 | 9.5 | 0.6 | F | 1700 | 40 | 0.08 | EEHAZA1J470B | 1000 |
| 80 | 56 | 10.0 | 9.5 | 0.6 | G | 1800 | 30 | 0.08 | EEHAZA1J560B | 500 |
| | 68 | 10.0 | 9.5 | 0.6 | G | 1800 | 30 | 0.08 | EEHAZA1J680B | 500 |
| | 82 | 10.0 | 9.5 | 0.6 | G | 1800 | 30 | 0.08 | EEHAZA1J820B | 500 |
| 80 | 22 | 8.0 | 9.5 | 0.6 | F | 1550 | 45 | 0.08 | EEHAZA1K220B | 1000 |
| | 33 | 10.0 | 9.5 | 0.6 | G | 1700 | 36 | 0.08 | EEHAZA1K330B | 500 |
| | 47 | 10.0 | 9.5 | 0.6 | G | 1700 | 36 | 0.08 | EEHAZA1K470B | 500 |

*1: Ripple current (100 kHz / +105 °C)

*2: ESR (100 kHz / +20 °C)

*3: tan δ (120 Hz / +20 °C)

◆ Please refer to the page of "Flow soldering profile" and "The taping dimensions".

Frequency correction factor for ripple current

| Rated capacitance (C) | Frequency (f) | 100 Hz ≤ f < 200 Hz | 200 Hz ≤ f < 300 Hz | 300 Hz ≤ f < 500 Hz | 500 Hz ≤ f < 1 kHz |
|-----------------------|-------------------|---------------------|----------------------|-----------------------|------------------------|
| C < 47 μF | Correction factor | 0.10 | 0.10 | 0.15 | 0.20 |
| 47 μF ≤ C < 150 μF | | 0.15 | 0.20 | 0.25 | 0.30 |
| 150 μF ≤ C | | 0.15 | 0.25 | 0.25 | 0.30 |
| Rated capacitance (C) | Frequency (f) | 1 kHz ≤ f < 2 kHz | 2 kHz ≤ f < 3 kHz | 3 kHz ≤ f < 5 kHz | 5 kHz ≤ f < 10 kHz |
| C < 47 μF | Correction factor | 0.30 | 0.40 | 0.45 | 0.50 |
| 47 μF ≤ C < 150 μF | | 0.40 | 0.45 | 0.55 | 0.60 |
| 150 μF ≤ C | | 0.45 | 0.50 | 0.60 | 0.65 |
| Rated capacitance (C) | Frequency (f) | 10 kHz ≤ f < 15 kHz | 15 kHz ≤ f < 20 kHz | 20 kHz ≤ f < 30 kHz | 30 kHz ≤ f < 40 kHz |
| C < 47 μF | Correction factor | 0.60 | 0.65 | 0.70 | 0.75 |
| 47 μF ≤ C < 150 μF | | 0.70 | 0.75 | 0.80 | 0.80 |
| 150 μF ≤ C | | 0.75 | 0.80 | 0.85 | 0.85 |
| Rated capacitance (C) | Frequency (f) | 40 kHz ≤ f < 50 kHz | 50 kHz ≤ f < 100 kHz | 100 kHz ≤ f < 500 kHz | 500 kHz ≤ f < 1000 kHz |
| C < 47 μF | Correction factor | 0.80 | 0.85 | 1.00 | 1.05 |
| 47 μF ≤ C < 150 μF | | 0.85 | 0.90 | 1.00 | 1.00 |
| 150 μF ≤ C | | 0.85 | 0.90 | 1.00 | 1.00 |

Design and specifications are each subject to change without notice. Ask factory for the current technical specifications before purchase and/or use.
Should a safety concern arise regarding this product, please be sure to contact us immediately.

**Conductive Polymer Hybrid Aluminum
Electrolytic Capacitors**
Radial Lead Type
ZC-A series

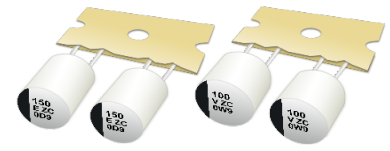

Features

- Endurance : 4000 h at 125 °C (125 °C standard product)
- Taping products for automatic insertion
- AEC-Q200 compliant
- RoHS compliant

Specifications

| | | |
|------------------------------|--|----------------------------------|
| Size code | F | G |
| Category temp. range | -55 °C to +125 °C | |
| Rated voltage range | 25 V to 80 V | |
| Nominal capacitance range | 22 µF to 220 µF | 33 µF to 330 µF |
| Capacitance tolerance | ±20 % (120 Hz / +20°C) | |
| Leakage current | I ≤ 0.01 CV (µA), 2 minutes after reaching rated voltage, 20 °C *CV = (Capacitance in µF) x (Rated voltage in V) | |
| Dissipation factor (tan δ) | Please see the attached characteristics list | |
| Surge voltage (V) | Rated voltage × 1.25 (15 °C to 35 °C) | |
| Endurance 1 | +125 °C ± 2 °C, 4000 h, apply the rated ripple current without exceeding the rated voltage. | |
| | Capacitance change | Within ±30% of the initial value |
| | Dissipation factor (tan δ) | ≤ 200 % of the initial limit |
| | ESR | ≤ 200 % of the initial limit |
| Endurance 2 | +125 °C ± 2 °C, 3000 h, apply the rated ripple current without exceeding the rated voltage. | |
| | Capacitance change | Within ±30% of the initial value |
| | Dissipation factor (tan δ) | ≤ 200 % of the initial limit |
| | ESR | ≤ 300 % of the initial limit |
| Shelf life | After storage for 1000 hours at +125 °C ± 2 °C with no voltage applied and then being stabilized at +20 °C, capacitors shall meet the limits specified in endurance 1. (Capacitors are left at room temperature and humidity for 2 hours after the test. Then, apply the rated voltage for 30min with a series protection resistance of 1000 Ω ± 10 Ω. Measure electrical characteristics after discharging the capacitor.) | |
| | +85 °C ± 2 °C, 85 % to 90 %RH, 2000 h, rated voltage applied | |
| Damp heat (Load) | Capacitance change | |
| | Dissipation factor (tan δ) | |
| | ESR | |
| | Leakage current | |
| Resistance to soldering heat | After flow soldering and then being stabilized at +20 °C, capacitors shall meet the following limits. | |
| | Capacitance change | |
| | Dissipation factor (tan δ) | |
| | Leakage current | |

Marking

Example : 25 V 150 µF
Marking color : BLACK

Negative polarity marking (-)

Capacitance (µF)

Series identification

Rated voltage code

Lot number

| R.voltage code | Unit : V |
|----------------|----------|
| E | 25 |
| V | 35 |
| H | 50 |
| J | 63 |
| K | 80 |

Dimensions (not to scale)

| Size code | øD | L | ød | F | P1 |
|-----------|------|-----|-----|-------------------------------------|-----------|
| F | 8.0 | 9.5 | 0.6 | 3.5±0.5 | 4.60±0.50 |
| G | 10.0 | 9.5 | 0.6 | 5.0 ^{+0.8} _{-0.2} | 3.85±0.50 |

Unit : mm

Explanation of part numbers

◆ Part number system e.g.: EEHAZC1E151B

| | | | | | | | | | | |
|------------------------|-----------|------|-------------------|--------|------------------|------|------------------|------|-----------------|------|
| EEHA | ZC | | 1E | | 151 | | | | B | |
| Product classification | Series | Code | Rated voltage (V) | Code * | Capacitance (μF) | Code | Capacitance (μF) | Code | Lead space (mm) | Code |
| | ZC | ZC | 25 | 1E | 22 | 220 | 100 | 101 | 3.5, 5.0 | B |
| | | | 35 | 1V | 33 | 330 | 120 | 121 | | |
| | | | 50 | 1H | 47 | 470 | 150 | 151 | | |
| | | | 63 | 1J | 56 | 560 | 220 | 221 | | |
| | | | 80 | 1K | 68 | 680 | 270 | 271 | | |
| | | | | | 82 | 820 | 330 | 331 | | |

*: If the total figures number of the part number exceeds 12 figures, "1" is omitted.

Characteristics list

Endurance 1 : 125 °C 4000 h

Endurance 2 : 125 °C 3000 h

| Rated voltage (V) | Capacitance (±20 %) (μF) | Case size (mm) | | | Size code | Specification | | | | Part number | Min. packaging q'ty (pcs) |
|-------------------|--------------------------|----------------|-----|-----|-----------|----------------------------|-------------|-------------|----------|--------------|---------------------------|
| | | øD | L | ød | | Ripple current *1 (mA rms) | | ESR *2 (mΩ) | tan δ *3 | | Taping |
| | | | | | | Endurance 1 | Endurance 2 | | | | |
| 25 | 150 | 8.0 | 9.5 | 0.6 | F | 1600 | 1900 | 27 | 0.14 | EEHAZC1E151B | 1000 |
| | 220 | 8.0 | 9.5 | 0.6 | F | 1600 | 1900 | 27 | 0.14 | EEHAZC1E221B | 1000 |
| | 330 | 10.0 | 9.5 | 0.6 | G | 2000 | 2900 | 20 | 0.14 | EEHAZC1E331B | 500 |
| 35 | 100 | 8.0 | 9.5 | 0.6 | F | 1600 | 1900 | 27 | 0.12 | EEHAZC1V101B | 1000 |
| | 150 | 8.0 | 9.5 | 0.6 | F | 1600 | 1900 | 27 | 0.12 | EEHAZC1V151B | 1000 |
| | 220 | 10.0 | 9.5 | 0.6 | G | 2000 | 2800 | 20 | 0.12 | EEHAZC1V221B | 500 |
| 50 | 270 | 10.0 | 9.5 | 0.6 | G | 2000 | 2800 | 20 | 0.12 | EEHAZC1V271B | 500 |
| | 47 | 8.0 | 9.5 | 0.6 | F | 1250 | - | 30 | 0.10 | EEHAZC1H470B | 1000 |
| | 68 | 8.0 | 9.5 | 0.6 | F | 1250 | - | 30 | 0.10 | EEHAZC1H680B | 1000 |
| 63 | 100 | 10.0 | 9.5 | 0.6 | G | 1600 | - | 28 | 0.10 | EEHAZC1H101B | 500 |
| | 120 | 10.0 | 9.5 | 0.6 | G | 1600 | - | 28 | 0.10 | EEHAZC1H121B | 500 |
| | 33 | 8.0 | 9.5 | 0.6 | F | 1100 | - | 40 | 0.08 | EEHAZC1J330B | 1000 |
| 80 | 47 | 8.0 | 9.5 | 0.6 | F | 1100 | - | 40 | 0.08 | EEHAZC1J470B | 1000 |
| | 56 | 10.0 | 9.5 | 0.6 | G | 1400 | - | 30 | 0.08 | EEHAZC1J560B | 500 |
| | 68 | 10.0 | 9.5 | 0.6 | G | 1400 | - | 30 | 0.08 | EEHAZC1J680B | 500 |
| 80 | 82 | 10.0 | 9.5 | 0.6 | G | 1400 | - | 30 | 0.08 | EEHAZC1J820B | 500 |
| | 22 | 8.0 | 9.5 | 0.6 | F | 1050 | - | 45 | 0.08 | EEHAZC1K220B | 1000 |
| | 33 | 10.0 | 9.5 | 0.6 | G | 1360 | - | 36 | 0.08 | EEHAZC1K330B | 500 |
| | 47 | 10.0 | 9.5 | 0.6 | G | 1360 | - | 36 | 0.08 | EEHAZC1K470B | 500 |

*1: Ripple current (100 kHz / +125 °C)

*2: ESR (100 kHz / +20 °C)

*3: tan δ (120 Hz / +20 °C)

◆ Please refer to the page of "Flow soldering profile" and "The taping dimensions".

Frequency correction factor for ripple current

| Rated capacitance (C) | Frequency (f) | 100 Hz ≤ f < 200 Hz | 200 Hz ≤ f < 300 Hz | 300 Hz ≤ f < 500 Hz | 500 Hz ≤ f < 1 kHz |
|-----------------------|-------------------|---------------------|---------------------|---------------------|--------------------|
| C < 47 μF | Correction factor | 0.10 | 0.10 | 0.15 | 0.20 |
| 47 μF ≤ C < 150 μF | | 0.15 | 0.20 | 0.25 | 0.30 |
| 150 μF ≤ C | | 0.15 | 0.25 | 0.25 | 0.30 |

| Rated capacitance (C) | Frequency (f) | 1 kHz ≤ f < 2 kHz | 2 kHz ≤ f < 3 kHz | 3 kHz ≤ f < 5 kHz | 5 kHz ≤ f < 10 kHz |
|-----------------------|-------------------|-------------------|-------------------|-------------------|--------------------|
| C < 47 μF | Correction factor | 0.30 | 0.40 | 0.45 | 0.50 |
| 47 μF ≤ C < 150 μF | | 0.40 | 0.45 | 0.55 | 0.60 |
| 150 μF ≤ C | | 0.45 | 0.50 | 0.60 | 0.65 |

| Rated capacitance (C) | Frequency (f) | 10 kHz ≤ f < 15 kHz | 15 kHz ≤ f < 20 kHz | 20 kHz ≤ f < 30 kHz | 30 kHz ≤ f < 40 kHz |
|-----------------------|-------------------|---------------------|---------------------|---------------------|---------------------|
| C < 47 μF | Correction factor | 0.60 | 0.65 | 0.70 | 0.75 |
| 47 μF ≤ C < 150 μF | | 0.70 | 0.75 | 0.80 | 0.80 |
| 150 μF ≤ C | | 0.75 | 0.80 | 0.85 | 0.85 |

| Rated capacitance (C) | Frequency (f) | 40 kHz ≤ f < 50 kHz | 50 kHz ≤ f < 100 kHz | 100 kHz ≤ f < 500 kHz | 500 kHz ≤ f < 1000 kHz |
|-----------------------|-------------------|---------------------|----------------------|-----------------------|------------------------|
| C < 47 μF | Correction factor | 0.80 | 0.85 | 1.00 | 1.05 |
| 47 μF ≤ C < 150 μF | | 0.85 | 0.90 | 1.00 | 1.00 |
| 150 μF ≤ C | | 0.85 | 0.90 | 1.00 | 1.00 |

After endurance ESR (100 kHz, -40 °C)

| Size code | F (ø8 x L9.5) | G (ø10 x L9.5) |
|-----------|---------------|----------------|
| ESR (Ω) | 0.4 | 0.3 |



Conductive Polymer Hybrid Aluminum Electrolytic Capacitors

Radial Lead Type

ZK-A series

Features

- Endurance : 4000 h at 125 °C (Large capacitance / High ripple current)
- Taping products for automatic insertion
- AEC-Q200 compliant
- RoHS compliant

Specifications

| Size code | F | | G | |
|------------------------------|--|----------------------------------|------------------|--|
| Category temp. range | -55 °C to +125 °C | | | |
| Rated voltage range | 25 V to 35 V | | | |
| Nominal capacitance range | 180 µF to 270 µF | | 330 µF to 470 µF | |
| Capacitance tolerance | ±20 % (120 Hz / +20°C) | | | |
| Leakage current | $I \leq 0.01 CV (\mu A)$, 2 minutes after reaching rated voltage, 20 °C *CV = (Capacitance in µF) x (Rated voltage in V) | | | |
| Dissipation factor (tan δ) | Please see the attached characteristics list | | | |
| Surge voltage (V) | Rated voltage × 1.25 (15 °C to 35 °C) | | | |
| Endurance | +125 °C ± 2 °C, 4000 h, apply the rated ripple current without exceeding the rated voltage. | | | |
| | Capacitance change | Within ±30% of the initial value | | |
| | Dissipation factor (tan δ) | ≤ 200 % of the initial limit | | |
| | ESR | ≤ 200 % of the initial limit | | |
| | Leakage current | Within the initial limit | | |
| | ESR after endurance (Ω / 100 kHz)(-40 °C) | Size code | | |
| | F | G | | |
| | 0.4 | 0.3 | | |
| Shelf life | After storage for 1000 hours at +125 °C ± 2 °C with no voltage applied and then being stabilized at +20 °C, capacitors shall meet the limits specified in endurance. (Capacitors are left at room temperature and humidity for 2 hours after the test. Then, apply the rated voltage for 30min with a series protection resistance of 1000 Ω ± 10 Ω. Measure electrical characteristics after discharging the capacitor.) | | | |
| Damp heat (Load) | +85 °C ± 2 °C, 85 % to 90 %RH, 2000 h, rated voltage applied | | | |
| | Capacitance change | Within ±30% of the initial value | | |
| | Dissipation factor (tan δ) | ≤ 200 % of the initial limit | | |
| | ESR | ≤ 200 % of the initial limit | | |
| | Leakage current | Within the initial limit | | |
| Resistance to soldering heat | After flow soldering and then being stabilized at +20 °C, capacitors shall meet the following limits. | | | |
| | Capacitance change | Within ±10% of the initial value | | |
| | Dissipation factor (tan δ) | Within the initial limit | | |
| | Leakage current | Within the initial limit | | |

Marking

Example : 25 V 270 µF
Marking color : BLACK

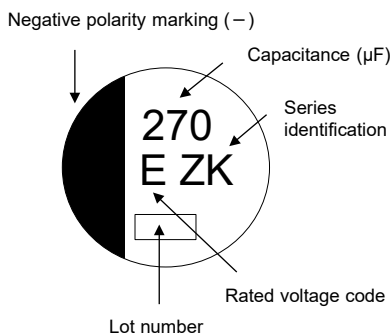

| R.voltage code | Unit : V |
|----------------|----------|
| E | 25 |
| V | 35 |

Dimensions (not to scale)

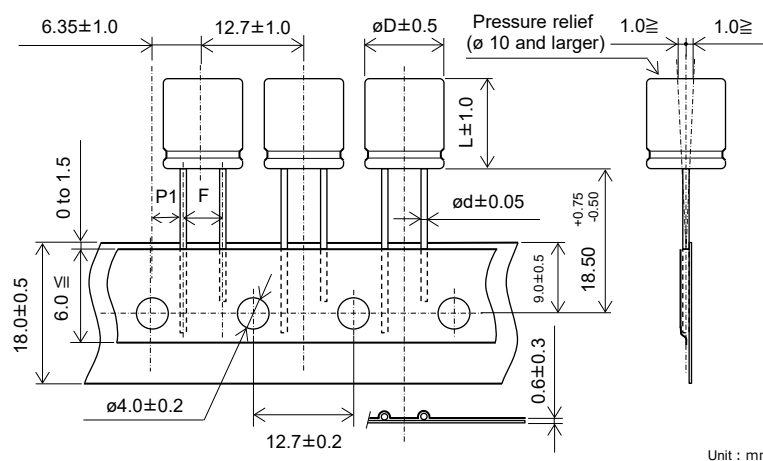

| Size code | øD | L | ød | F | P1 |
|-----------|------|-----|-----|-------------------------------------|-----------|
| F | 8.0 | 9.5 | 0.6 | 3.5±0.5 | 4.60±0.50 |
| G | 10.0 | 9.5 | 0.6 | 5.0 ^{+0.8} _{-0.2} | 3.85±0.50 |

Explanation of part numbers

◆ Part number system e.g.: EEHAZK1E271B

| | | | | | | | | | | |
|------------------------|-----------|------|-------------------|-------|------------------|------|------------------|------|-----------------|------|
| EEHA | ZK | | 1E | | 271 | | | | B | |
| Product classification | Series | Code | Rated voltage (V) | Code* | Capacitance (μF) | Code | Capacitance (μF) | Code | Lead space (mm) | Code |
| | ZK | ZK | 25 | 1E | 180 | 181 | 330 | 331 | 3.5, 5.0 | B |
| | | | 35 | 1V | 270 | 271 | 470 | 471 | | |

*: If the total figures number of the part number exceeds 12 figures, "1" is omitted.

Characteristics list

Endurance : 125 °C 4000 h

| Rated voltage (V) | Capacitance (±20 %) (μF) | Case size (mm) | | | Size code | Specification | | | Part number | Min. packaging q'ty (pcs) |
|-------------------|--------------------------|----------------|-----|-----|-----------|---------------------------------------|------------------------|---------------------|--------------|---------------------------|
| | | øD | L | ød | | Ripple current* ¹ (mA rms) | ESR* ² (mΩ) | tan δ* ³ | | Taping |
| 25 | 270 | 8.0 | 9.5 | 0.6 | F | 2000 | 27 | 0.14 | EEHAZK1E271B | 1000 |
| | 470 | 10.0 | 9.5 | 0.6 | G | 2800 | 20 | 0.14 | EEHAZK1E471B | 500 |
| 35 | 180 | 8.0 | 9.5 | 0.6 | F | 2000 | 27 | 0.12 | EEHAZK1V181B | 1000 |
| | 330 | 10.0 | 9.5 | 0.6 | G | 2800 | 20 | 0.12 | EEHAZK1V331B | 500 |

*1: Ripple current (100 kHz / +125 °C)

*2: ESR (100 kHz / +20 °C)

*3: tan δ (120 Hz / +20 °C)

◆ Please refer to the page of "Flow soldering profile" and "The taping dimensions".

Frequency correction factor for ripple current

| Frequency (f) | 100 Hz ≤ f < 120 Hz | 120 Hz ≤ f < 200 Hz | 200 Hz ≤ f < 300 Hz | 300 Hz ≤ f < 500 Hz |
|-------------------|---------------------|---------------------|----------------------|------------------------|
| Correction factor | 0.15 | 0.20 | 0.25 | 0.30 |
| Frequency (f) | 500 Hz ≤ f < 1 kHz | 1 kHz ≤ f < 2 kHz | 2 kHz ≤ f < 3 kHz | 3 kHz ≤ f < 5 kHz |
| Correction factor | 0.40 | 0.50 | 0.60 | 0.65 |
| Frequency (f) | 5 kHz ≤ f < 10 kHz | 10 kHz ≤ f < 15 kHz | 15 kHz ≤ f < 20 kHz | 20 kHz ≤ f < 30 kHz |
| Correction factor | 0.70 | 0.75 | 0.80 | 0.85 |
| Frequency (f) | 30 kHz ≤ f < 40 kHz | 40 kHz ≤ f < 50 kHz | 50 kHz ≤ f < 100 kHz | 100 kHz ≤ f < 1000 kHz |
| Correction factor | 0.85 | 0.85 | 0.90 | 1.00 |

**Conductive Polymer Hybrid Aluminum
Electrolytic Capacitors**
Radial Lead Type
ZKU-A series



Features

- Endurance : 4000 h at 125 °C (Large capacitance / High ripple current)
- Taping products for automatic insertion
- AEC-Q200 compliant
- RoHS compliant

Specifications

| Size code | F | G |
|------------------------------|--|----------------------------------|
| Category temp. range | -55 °C to +125 °C | |
| Rated voltage range | 25 V to 35 V | |
| Nominal capacitance range | 220 µF to 330 µF | 390 µF to 560 µF |
| Capacitance tolerance | ±20 % (120 Hz / +20°C) | |
| Leakage current | I ≤ 0.01 CV (µA), 2 minutes after reaching rated voltage, 20 °C *CV = (Capacitance in µF) x (Rated voltage in V) | |
| Dissipation factor (tan δ) | Please see the attached characteristics list | |
| Surge voltage (V) | Rated voltage × 1.25 (15 °C to 35 °C) | |
| Endurance | +125 °C ± 2 °C, 4000 h, apply the rated ripple current without exceeding the rated voltage. | |
| | Capacitance change | Within ±30% of the initial value |
| | Dissipation factor (tan δ) | ≤ 200 % of the initial limit |
| | ESR | ≤ 200 % of the initial limit |
| | Leakage current | Within the initial limit |
| Shelf life | After storage for 1000 hours at +125 °C ± 2 °C with no voltage applied and then being stabilized at +20 °C, capacitors shall meet the limits specified in endurance. (Capacitors are left at room temperature and humidity for 2 hours after the test. Then, apply the rated voltage for 30min with a series protection resistance of 1000 Ω ± 10 Ω. Measure electrical characteristics after discharging the capacitor.) | |
| | +85 °C ± 2 °C, 85 % to 90 %RH, 2000 h, rated voltage applied | |
| | Damp heat (Load) | |
| Resistance to soldering heat | After flow soldering and then being stabilized at +20 °C, capacitors shall meet the following limits. | |
| | Capacitance change | Within ±10% of the initial value |
| | Dissipation factor (tan δ) | Within the initial limit |
| | Leakage current | Within the initial limit |

Marking

Example : 25 V 330 µF
Marking color : BLACK

Negative polarity marking (-)

Capacitance (µF)

Series identification

Rated voltage code

Lot number

| R.voltage code | Unit : V |
|----------------|----------|
| E | 25 |
| V | 35 |

Dimensions (not to scale)

| Size code | øD | L | ød | F | P1 |
|-----------|------|-----|-----|-------------------------------------|-----------|
| F | 8.0 | 9.5 | 0.6 | 3.5±0.5 | 4.60±0.50 |
| G | 10.0 | 9.5 | 0.6 | 5.0 ^{+0.8} _{-0.2} | 3.85±0.50 |

Unit : mm

Explanation of part numbers

◆ Part number system e.g.: EEHAZKE331UB

| EEHA | ZK | | E | | 331 | | U | | B | |
|------------------------|--------|------|-------------------|--------|------------------|------|-------------------------|------|-----------------|------|
| Product classification | Series | Code | Rated voltage (V) | Code * | Capacitance (μF) | Code | Dia øD | Code | Lead space (mm) | Code |
| | ZKU | ZK | 25 | 1E | 220 | 221 | Miniaturization product | U | 3.5, 5.0 | B |
| | | | 35 | 1V | 330 | 331 | | | | |
| | | | | | 390 | 391 | | | | |
| | | | | | 560 | 561 | | | | |

*: If the total figures number of the part number exceeds 12 figures, "1" is omitted.

Characteristics list

Endurance : 125 °C 4000 h

| Rated voltage (V) | Capacitance (±20 %) (μF) | Case size (mm) | | | Size code | Specification | | | Part number | Min. packaging q'ty (pcs) |
|-------------------|--------------------------|----------------|-----|-----|-----------|---------------------------------------|------------------------|---------------------|--------------|---------------------------|
| | | øD | L | ød | | Ripple current ^{*1} (mA rms) | ESR ^{*2} (mΩ) | tan δ ^{*3} | | Taping |
| 25 | 330 | 8.0 | 9.5 | 0.6 | F | 2000 | 27 | 0.14 | EEHAZKE331UB | 1000 |
| | 560 | 10.0 | 9.5 | 0.6 | G | 2800 | 20 | 0.14 | EEHAZKE561UB | 500 |
| 35 | 220 | 8.0 | 9.5 | 0.6 | F | 2000 | 27 | 0.12 | EEHAZKV221UB | 1000 |
| | 390 | 10.0 | 9.5 | 0.6 | G | 2800 | 20 | 0.12 | EEHAZKV391UB | 500 |

*1: Ripple current (100 kHz / +125 °C)

*2: ESR (100 kHz / +20 °C)

*3: tan δ (120 Hz / +20 °C)

◆ Please refer to the page of "Flow soldering profile" and "The taping dimensions".

Frequency correction factor for ripple current

| | | | | |
|-------------------|---------------------|---------------------|----------------------|------------------------|
| Frequency (f) | 100 Hz ≤ f < 120 Hz | 120 Hz ≤ f < 200 Hz | 200 Hz ≤ f < 300 Hz | 300 Hz ≤ f < 500 Hz |
| Correction factor | 0.15 | 0.20 | 0.25 | 0.30 |
| Frequency (f) | 500 Hz ≤ f < 1 kHz | 1 kHz ≤ f < 2 kHz | 2 kHz ≤ f < 3 kHz | 3 kHz ≤ f < 5 kHz |
| Correction factor | 0.40 | 0.50 | 0.60 | 0.65 |
| Frequency (f) | 5 kHz ≤ f < 10 kHz | 10 kHz ≤ f < 15 kHz | 15 kHz ≤ f < 20 kHz | 20 kHz ≤ f < 30 kHz |
| Correction factor | 0.70 | 0.75 | 0.80 | 0.85 |
| Frequency (f) | 30 kHz ≤ f < 40 kHz | 40 kHz ≤ f < 50 kHz | 50 kHz ≤ f < 100 kHz | 100 kHz ≤ f < 1000 kHz |
| Correction factor | 0.85 | 0.85 | 0.90 | 1.00 |

**Conductive Polymer Hybrid Aluminum
Electrolytic Capacitors**
Radial Lead Type
ZT-A series

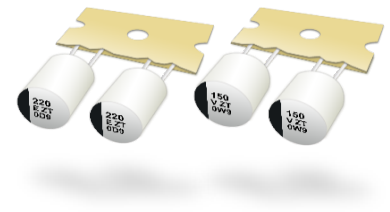

Features

- Endurance : 4000 h at 135 °C / 125 °C (High ripple current)
- Taping products for automatic insertion
- AEC-Q200 compliant
- RoHS compliant

Specifications

| | | | | |
|------------------------------|--|---|-----------------|--|
| Size code | F | | G | |
| Category temp. range | -55 °C to +135 °C | | | |
| Rated voltage range | 25 V to 63 V | | | |
| Nominal capacitance range | 33 µF to 220 µF | | 56 µF to 330 µF | |
| Capacitance tolerance | ±20 % (120 Hz / +20°C) | | | |
| Leakage current | $I \leq 0.01 CV$ (µA) 2 minutes after reaching rated voltage, 20 °C *CV = (Capacitance in µF) x (Rated voltage in V) | | | |
| Dissipation factor (tan δ) | Please see the attached characteristics list | | | |
| Surge voltage (V) | Rated voltage × 1.25 (15 °C to 35 °C) | | | |
| Endurance 1 | +125 °C ± 2 °C, 4000 h, apply the rated ripple current without exceeding the rated voltage. | | | |
| | Capacitance change | Within ±30% of the initial value | | |
| | Dissipation factor (tan δ) | ≤ 200 % of the initial limit | | |
| | ESR | ≤ 200 % of the initial limit | | |
| | Leakage current | Within the initial limit | | |
| Endurance 2 | +135 °C ± 2 °C, 4000 h, apply the rated ripple current without exceeding the rated voltage. | | | |
| | Capacitance change | Within ±30% of the initial value | | |
| | Dissipation factor (tan δ) | ≤ 200 % of the initial limit | | |
| | ESR | ≤ 200 % of the initial limit | | |
| | Leakage current | Within the initial limit | | |
| Shelf life | After storage for 1000 hours at +135 °C ± 2 °C with no voltage applied and then being stabilized at +20 °C, capacitors shall meet the limits specified in endurance. (Capacitors are left at room temperature and humidity for 2 hours after the test. Then, apply the rated voltage for 30min with a series protection resistance of 1000 Ω ± 10 Ω. Measure electrical characteristics after discharging the capacitor.) | | | |
| | +85 °C ± 2 °C, 85 % to 90 %RH, 2000 h, rated voltage applied | | | |
| | Capacitance change | Within ±30% of the initial value | | |
| Damp heat (Load) | Dissipation factor (tan δ) | ≤ 200 % of the initial limit | | |
| | ESR | ≤ 200 % of the initial limit | | |
| | Leakage current | Within the initial limit | | |
| | Resistance to soldering heat | After flow soldering and then being stabilized at +20 °C, capacitors shall meet the following limits. | | |
| Resistance to soldering heat | Capacitance change | Within ±10% of the initial value | | |
| | Dissipation factor (tan δ) | Within the initial limit | | |
| | Leakage current | Within the initial limit | | |

Marking

Example : 25 V 220 µF
Marking color : BLACK

Negative polarity marking (-)

Capacitance (µF)

Series identification

Rated voltage code

Lot number

| | |
|----------------|----------|
| R.voltage code | Unit : V |
| E | 25 |
| V | 35 |
| H | 50 |
| J | 63 |

Dimensions (not to scale)

| | | | | | |
|-----------|------|-----|-----|----------|-----------|
| Size code | øD | L | ød | F | P1 |
| F | 8.0 | 9.5 | 0.6 | 3.5±0.5 | 4.60±0.50 |
| G | 10.0 | 9.5 | 0.6 | 5.0 ±0.8 | 3.85±0.50 |

Unit : mm

Explanation of part numbers

◆ Part number system e.g.: EEHAZT1E221B

| EEHA | ZT | | 1E | | 221 | | B | | | |
|------------------------|--------|------|-------------------|-------|------------------|------|------------------|------|-----------------|------|
| Product classification | Series | Code | Rated voltage (V) | Code* | Capacitance (μF) | Code | Capacitance (μF) | Code | Lead space (mm) | Code |
| | ZT | ZT | 25 | 1E | 33 | 330 | 120 | 121 | 3.5, 5.0 | B |
| | | | 35 | 1V | 47 | 470 | 150 | 151 | | |
| | | | 50 | 1H | 56 | 560 | 220 | 221 | | |
| | | | 63 | 1J | 68 | 680 | 270 | 271 | | |
| | | | | | 82 | 820 | 330 | 331 | | |
| | | | | | 100 | 101 | | | | |

*: If the total figures number of the part number exceeds 12 figures, "1" is omitted.

Characteristics list

Endurance 1 : 125 °C 4000 h

Endurance 2 : 135 °C 4000 h

| Rated voltage (V) | Capacitance (±20 %) (μF) | Case size (mm) | | | Size code | Specification | | | | Part number | Min. packaging qty (pcs) |
|-------------------|--------------------------|----------------|-----|-----|-----------|---------------------------|-----------------------|------------|---------|--------------|--------------------------|
| | | øD | L | ød | | Ripple current*1 (mA rms) | | ESR*2 (mΩ) | tan δ*3 | | |
| | | | | | | Endurance 1 (+125 °C) | Endurance 2 (+135 °C) | | | | |
| 25 | 220 | 8.0 | 9.5 | 0.6 | F | 2900 | 1800 | 22 | 0.14 | EEHAZT1E221B | 1000 |
| | 330 | 10.0 | 9.5 | 0.6 | G | 3500 | 2200 | 16 | 0.14 | EEHAZT1E331B | 500 |
| 35 | 150 | 8.0 | 9.5 | 0.6 | F | 2900 | 1800 | 22 | 0.12 | EEHAZT1V151B | 1000 |
| | 270 | 10.0 | 9.5 | 0.6 | G | 3500 | 2200 | 16 | 0.12 | EEHAZT1V271B | 500 |
| 50 | 68 | 8.0 | 9.5 | 0.6 | F | 2700 | 1700 | 25 | 0.10 | EEHAZT1H680B | 1000 |
| | 100 | 10.0 | 9.5 | 0.6 | G | 2900 | 1800 | 23 | 0.10 | EEHAZT1H101B | 500 |
| | 120 | 10.0 | 9.5 | 0.6 | G | 2900 | 1800 | 23 | 0.10 | EEHAZT1H121B | 500 |
| 63 | 33 | 8.0 | 9.5 | 0.6 | F | 2400 | 1500 | 32 | 0.08 | EEHAZT1J330B | 1000 |
| | 47 | 8.0 | 9.5 | 0.6 | F | 2400 | 1500 | 32 | 0.08 | EEHAZT1J470B | 1000 |
| | 56 | 10.0 | 9.5 | 0.6 | G | 2800 | 1700 | 25 | 0.08 | EEHAZT1J560B | 500 |
| | 68 | 10.0 | 9.5 | 0.6 | G | 2800 | 1700 | 25 | 0.08 | EEHAZT1J680B | 500 |
| | 82 | 10.0 | 9.5 | 0.6 | G | 2800 | 1700 | 25 | 0.08 | EEHAZT1J820B | 500 |

*1: Ripple current (100 kHz / +125 °C or +135 °C)

*2: ESR (100 kHz / +20 °C)

*3: tan δ (120 Hz / +20 °C)

◆ Please refer to the page of "Flow soldering profile" and "The taping dimensions".

Frequency correction factor for ripple current

| Rated capacitance (C) | Frequency (f) | 100 Hz ≤ f < 200 Hz | 200 Hz ≤ f < 300 Hz | 300 Hz ≤ f < 500 Hz | 500 Hz ≤ f < 1 kHz |
|-----------------------|-------------------|---------------------|----------------------|-----------------------|------------------------|
| C < 47 μF | Correction factor | 0.10 | 0.10 | 0.15 | 0.20 |
| 47 μF ≤ C < 150 μF | | 0.15 | 0.20 | 0.25 | 0.30 |
| 150 μF ≤ C | | 0.15 | 0.25 | 0.25 | 0.30 |
| Rated capacitance (C) | Frequency (f) | 1 kHz ≤ f < 2 kHz | 2 kHz ≤ f < 3 kHz | 3 kHz ≤ f < 5 kHz | 5 kHz ≤ f < 10 kHz |
| C < 47 μF | Correction factor | 0.30 | 0.40 | 0.45 | 0.50 |
| 47 μF ≤ C < 150 μF | | 0.40 | 0.45 | 0.55 | 0.60 |
| 150 μF ≤ C | | 0.45 | 0.50 | 0.60 | 0.65 |
| Rated capacitance (C) | Frequency (f) | 10 kHz ≤ f < 15 kHz | 15 kHz ≤ f < 20 kHz | 20 kHz ≤ f < 30 kHz | 30 kHz ≤ f < 40 kHz |
| C < 47 μF | Correction factor | 0.60 | 0.65 | 0.70 | 0.75 |
| 47 μF ≤ C < 150 μF | | 0.70 | 0.75 | 0.80 | 0.80 |
| 150 μF ≤ C | | 0.75 | 0.80 | 0.85 | 0.85 |
| Rated capacitance (C) | Frequency (f) | 40 kHz ≤ f < 50 kHz | 50 kHz ≤ f < 100 kHz | 100 kHz ≤ f < 500 kHz | 500 kHz ≤ f < 1000 kHz |
| C < 47 μF | Correction factor | 0.80 | 0.85 | 1.00 | 1.05 |
| 47 μF ≤ C < 150 μF | | 0.85 | 0.90 | 1.00 | 1.00 |
| 150 μF ≤ C | | 0.85 | 0.90 | 1.00 | 1.00 |

**Conductive Polymer Hybrid Aluminum
Electrolytic Capacitors**
Radial Lead Type
ZS-A series

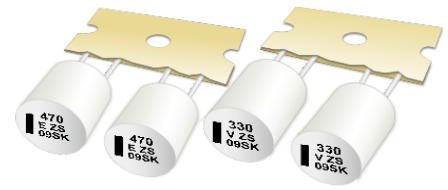

Features

- Endurance : 4000 h at 135 °C / 125 °C (Large capacitance / High ripple current / Low ESR)
- Taping products for automatic insertion
- AEC-Q200 compliant
- RoHS compliant

Specifications

| Size code | G12 | | G16 | |
|------------------------------|--|----------------------------------|------------------|--|
| Category temp. range | -55 °C to +135 °C | | | |
| Rated voltage range | 25 V to 63 V | | | |
| Nominal capacitance range | 100 µF to 470 µF | | 150 µF to 560 µF | |
| Capacitance tolerance | ±20 % (120 Hz / +20°C) | | | |
| Leakage current | $I \leq 0.01 CV (\mu A)$ 2 minutes after reaching rated voltage, 20 °C *CV = (Capacitance in µF) x (Rated voltage in V) | | | |
| Dissipation factor (tan δ) | Please see the attached characteristics list | | | |
| Surge voltage (V) | Rated voltage × 1.25 (15 °C to 35 °C) | | | |
| Endurance 1 | +125 °C ± 2 °C, 4000 h, apply the rated ripple current without exceeding the rated voltage. | | | |
| | Capacitance change | Within ±30% of the initial value | | |
| | Dissipation factor (tan δ) | ≤ 200 % of the initial limit | | |
| | ESR | ≤ 200 % of the initial limit | | |
| Endurance 2 | +135 °C ± 2 °C, 4000 h, apply the rated ripple current without exceeding the rated voltage. | | | |
| | Capacitance change | Within ±30% of the initial value | | |
| | Dissipation factor (tan δ) | ≤ 200 % of the initial limit | | |
| | ESR | ≤ 200 % of the initial limit | | |
| Shelf life | After storage for 1000 hours at +135 °C ± 2 °C with no voltage applied and then being stabilized at +20 °C, capacitors shall meet the limits specified in endurance. (Capacitors are left at room temperature and humidity for 2 hours after the test. Then, apply the rated voltage for 30min with a series protection resistance of 1000 Ω ± 10 Ω. Measure electrical characteristics after discharging the capacitor.) | | | |
| | +85 °C ± 2 °C, 85 % to 90 %RH, 2000 h, rated voltage applied | | | |
| Damp heat (Load) | +85 °C ± 2 °C, 85 % to 90 %RH, 2000 h, rated voltage applied | | | |
| | Capacitance change | Within ±30% of the initial value | | |
| | Dissipation factor (tan δ) | ≤ 200 % of the initial limit | | |
| | ESR | ≤ 200 % of the initial limit | | |
| Resistance to soldering heat | After flow soldering and then being stabilized at +20 °C, capacitors shall meet the following limits. | | | |
| | Capacitance change | Within ±10% of the initial value | | |
| | Dissipation factor (tan δ) | Within the initial limit | | |
| | Leakage current | Within the initial limit | | |

Marking

Example : 25 V 470 µF
Marking color : BLACK

Negative polarity marking (-)

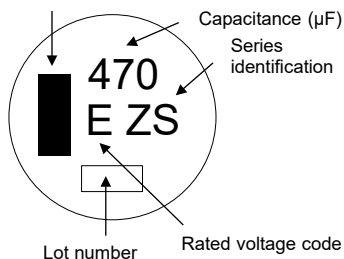

| R.voltage code | Unit : V |
|----------------|----------|
| E | 25 |
| V | 35 |
| H | 50 |
| J | 63 |

Dimensions (not to scale)

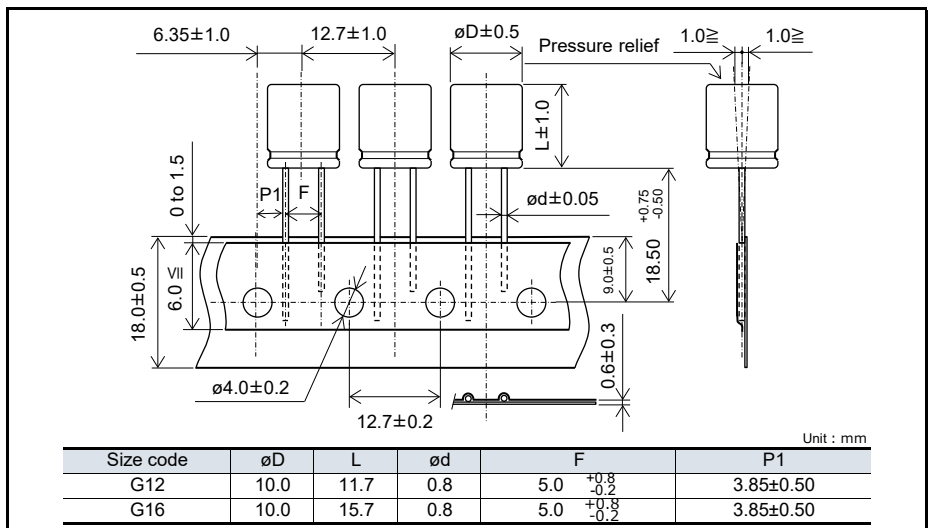

Explanation of part numbers

◆ Part number system e.g.: EEHAZS1E471B

| | | | | | | | | | | |
|------------------------|-----------|------|-------------------|-------|------------------|------|------------------|------|-----------------|------|
| EEHA | ZS | | 1E | | 471 | | | | B | |
| Product classification | Series | Code | Rated voltage (V) | Code* | Capacitance (μF) | Code | Capacitance (μF) | Code | Lead space (mm) | Code |
| | ZS | ZS | 25 | 1E | 100 | 101 | 330 | 331 | 3.5, 5.0 | B |
| | | | 35 | 1V | 150 | 151 | 470 | 471 | | |
| | | | 50 | 1H | 220 | 221 | 560 | 561 | | |
| | | | 63 | 1J | | | | | | |

*: If the total figures number of the part number exceeds 12 figures, "1" is omitted.

Characteristics list

Endurance 1 : 125 °C 4000 h
Endurance 2 : 135 °C 4000 h

| Rated voltage (V) | Capacitance (±20 %) (μF) | Case size (mm) | | | Size code | Specification | | | | Part number | Min. packaging q'ty (pcs) |
|-------------------|--------------------------|----------------|------|-----|-----------|---------------------------------------|----------------------|------------------------|---------------------|--------------|---------------------------|
| | | øD | L | ød | | Ripple current* ¹ (mA rms) | | ESR* ² (mΩ) | tan δ* ³ | | Taping |
| | | | | | | Endurance 1 (+125°C) | Endurance 2 (+135°C) | | | | |
| 25 | 470 | 10.0 | 11.7 | 0.8 | G12 | 3500 | 2500 | 14 | 0.14 | EEHAZS1E471B | 500 |
| | 560 | 10.0 | 15.7 | 0.8 | G16 | 4000 | 2900 | 11 | 0.14 | EEHAZS1E561B | 500 |
| 35 | 330 | 10.0 | 11.7 | 0.8 | G12 | 3500 | 2500 | 14 | 0.12 | EEHAZS1V331B | 500 |
| | 470 | 10.0 | 15.7 | 0.8 | G16 | 4000 | 2900 | 11 | 0.12 | EEHAZS1V471B | 500 |
| 50 | 150 | 10.0 | 11.7 | 0.8 | G12 | 3200 | 2250 | 17 | 0.10 | EEHAZS1H151B | 500 |
| | 220 | 10.0 | 15.7 | 0.8 | G16 | 3700 | 2600 | 13 | 0.10 | EEHAZS1H221B | 500 |
| 63 | 100 | 10.0 | 11.7 | 0.8 | G12 | 3000 | 2100 | 19 | 0.08 | EEHAZS1J101B | 500 |
| | 150 | 10.0 | 15.7 | 0.8 | G16 | 3500 | 2400 | 15 | 0.08 | EEHAZS1J151B | 500 |

*1: Ripple current (100 kHz / +125 °C or +135 °C)

*2: ESR (100 kHz / +20 °C)

*3: tan δ (120 Hz / +20 °C)

◆ Please refer to the page of "Flow soldering profile" and "The taping dimensions".

Frequency correction factor for ripple current

| Rated capacitance (C) | Frequency (f) | 100 Hz ≤ f < 200 Hz | 200 Hz ≤ f < 300 Hz | 300 Hz ≤ f < 500 Hz | 500 Hz ≤ f < 1 kHz |
|-----------------------|-------------------|---------------------|---------------------|---------------------|--------------------|
| 100 μF ≤ C < 150 μF | Correction factor | 0.15 | 0.20 | 0.25 | 0.30 |
| | 150 μF ≤ C | 0.15 | 0.25 | 0.25 | 0.30 |
| 100 μF ≤ C < 150 μF | Correction factor | 0.40 | 0.45 | 0.55 | 0.60 |
| | 150 μF ≤ C | 0.45 | 0.50 | 0.60 | 0.65 |
| 100 μF ≤ C < 150 μF | Correction factor | 0.70 | 0.75 | 0.80 | 0.80 |
| | 150 μF ≤ C | 0.75 | 0.80 | 0.85 | 0.85 |
| 100 μF ≤ C < 150 μF | Correction factor | 0.85 | 0.90 | 1.00 | 1.00 |
| | 150 μF ≤ C | 0.85 | 0.90 | 1.00 | 1.00 |

**Conductive Polymer Hybrid Aluminum
Electrolytic Capacitors**
Radial Lead Type
ZSU-A series

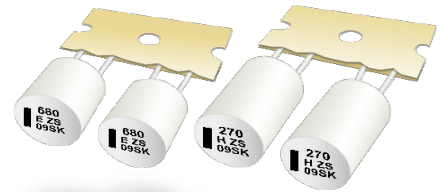

Features

- Endurance : 4000 h at 135 °C / 125 °C
- Large capacitance compared with ZS series
- Taping products for automatic insertion
- AEC-Q200 compliant
- RoHS compliant

Specifications

| Size code | G12 | | G16 | |
|------------------------------|--|---|-------------------|--|
| Category temp. range | -55 °C to +135 °C | | | |
| Rated voltage range | 25 V to 63 V | | | |
| Nominal capacitance range | 120 µF to 680 µF | | 180 µF to 1000 µF | |
| Capacitance tolerance | ±20 % (120 Hz / +20°C) | | | |
| Leakage current | I ≤ 0.01 CV (µA), 2 minutes after reaching rated voltage, 20 °C *CV = (Capacitance in µF) x (Rated voltage in V) | | | |
| Dissipation factor (tan δ) | Please see the attached characteristics list | | | |
| Surge voltage (V) | Rated voltage × 1.25 (15 °C to 35 °C) | | | |
| Endurance 1 | +125 °C ± 2 °C, 4000 h, apply the rated ripple current without exceeding the rated voltage. | | | |
| | Capacitance change | Within ±30% of the initial value | | |
| | Dissipation factor (tan δ) | ≤ 200 % of the initial limit | | |
| | ESR | ≤ 200 % of the initial limit | | |
| | Leakage current | Within the initial limit | | |
| Endurance 2 | +135 °C ± 2 °C, 4000 h, apply the rated ripple current without exceeding the rated voltage. | | | |
| | Capacitance change | Within ±30% of the initial value | | |
| | Dissipation factor (tan δ) | ≤ 200 % of the initial limit | | |
| | ESR | ≤ 200 % of the initial limit | | |
| | Leakage current | Within the initial limit | | |
| Shelf life | After storage for 1000 hours at +135 °C ± 2 °C with no voltage applied and then being stabilized at +20 °C, capacitors shall meet the limits specified in endurance. (Capacitors are left at room temperature and humidity for 2 hours after the test. Then, apply the rated voltage for 30min with a series protection resistance of 1000 Ω ± 10 Ω. Measure electrical characteristics after discharging the capacitor.) | | | |
| | +85 °C ± 2 °C, 85 % to 90 %RH, 2000 h, rated voltage applied | | | |
| | Capacitance change | Within ±30% of the initial value | | |
| Damp heat (Load) | Dissipation factor (tan δ) | ≤ 200 % of the initial limit | | |
| | ESR | ≤ 200 % of the initial limit | | |
| | Leakage current | Within the initial limit | | |
| | Resistance to soldering heat | After flow soldering and then being stabilized at +20 °C, capacitors shall meet the following limits. | | |
| Resistance to soldering heat | Capacitance change | Within ±10% of the initial value | | |
| | Dissipation factor (tan δ) | Within the initial limit | | |
| | Leakage current | Within the initial limit | | |

Marking

Example : 25 V 680 µF
Marking color : BLACK

Negative polarity marking (-)

Capacitance (µF)
Series identification
Rated voltage code

| R.voltage code | Unit : V |
|----------------|----------|
| E | 25 |
| V | 35 |
| H | 50 |
| J | 63 |

Dimensions (not to scale)

| Size code | øD | L | ød | F | P1 |
|-----------|------|------|-----|------------------|-----------|
| G12 | 10.0 | 11.7 | 0.8 | 5.0 +0.8 -0.2 | 3.85±0.50 |
| G16 | 10.0 | 15.7 | 0.8 | 5.0 +0.8 -0.2 | 3.85±0.50 |

Unit : mm

Explanation of part numbers

◆ Part number system e.g.: EEHAZSE681UB

| EEHA | ZS | | E | | 681 | | U | | B | |
|------------------------|--------|------|-------------------|--------|------------------|------|-------------------------|------|-----------------|------|
| Product classification | Series | Code | Rated voltage (V) | Code * | Capacitance (μF) | Code | Dia øD | Code | Lead space (mm) | Code |
| | ZSU | ZS | 25 | 1E | 120 | 121 | Miniaturization product | U | 3.5, 5.0 | B |
| | | | 35 | 1V | 180 | 181 | | | | |
| | | | 50 | 1H | 270 | 271 | | | | |
| | | | 63 | 1J | 470 | 471 | | | | |
| | | | | | 680 | 681 | | | | |
| | | | | | 1000 | 102 | | | | |

*: If the total figures number of the part number exceeds 12 figures, "1" is omitted.

Characteristics list

Endurance 1 : 125 °C 4000 h

Endurance 2 : 135 °C 4000 h

| Rated voltage (V) | Capacitance (±20 %) (μF) | Case size (mm) | | | Size code | Specification | | | | Part number | Min. packaging q'ty (pcs) |
|-------------------|--------------------------|----------------|------|-----|-----------|---------------------------------------|-----------------------|------------------------|---------------------|--------------|---------------------------|
| | | øD | L | ød | | Ripple current* ¹ (mA rms) | | ESR* ² (mΩ) | tan δ* ³ | | Taping |
| | | | | | | Endurance 1 (+125 °C) | Endurance 2 (+135 °C) | | | | |
| 25 | 680 | 10.0 | 11.7 | 0.8 | G12 | 3500 | 2500 | 14 | 0.14 | EEHAZSE681UB | 500 |
| | 1000 | 10.0 | 15.7 | 0.8 | G16 | 4000 | 2900 | 11 | 0.14 | EEHAZSE102UB | 500 |
| 35 | 470 | 10.0 | 11.7 | 0.8 | G12 | 3500 | 2500 | 14 | 0.12 | EEHAZSV471UB | 500 |
| | 680 | 10.0 | 15.7 | 0.8 | G16 | 4000 | 2900 | 11 | 0.12 | EEHAZSV681UB | 500 |
| 50 | 180 | 10.0 | 11.7 | 0.8 | G12 | 3200 | 2250 | 17 | 0.10 | EEHAZSH181UB | 500 |
| | 270 | 10.0 | 15.7 | 0.8 | G16 | 3700 | 2600 | 13 | 0.10 | EEHAZSH271UB | 500 |
| 63 | 120 | 10.0 | 11.7 | 0.8 | G12 | 3000 | 2100 | 19 | 0.08 | EEHAZSJ121UB | 500 |
| | 180 | 10.0 | 15.7 | 0.8 | G16 | 3500 | 2400 | 15 | 0.08 | EEHAZSJ181UB | 500 |

*1: Ripple current (100 kHz / +125 °C or +135 °C)

*2: ESR (100 kHz / +20 °C)

*3: tan δ (120 Hz / +20 °C)

◆ Please refer to the page of "Flow soldering profile" and "The taping dimensions".

Frequency correction factor for ripple current

| Rated capacitance (C) | Frequency (f) | 100 Hz ≤ f < 120 Hz | 120 Hz ≤ f < 200 Hz | 200 Hz ≤ f < 300 Hz | 300 Hz ≤ f < 500 Hz |
|-----------------------|-------------------|---------------------|---------------------|---------------------|---------------------|
| 120 μF ≤ C | Correction factor | 0.15 | 0.20 | 0.25 | 0.30 |

| Rated capacitance (C) | Frequency (f) | 500 Hz ≤ f < 1 kHz | 1 kHz ≤ f < 2 kHz | 2 kHz ≤ f < 3 kHz | 3 kHz ≤ f < 5 kHz |
|-----------------------|-------------------|--------------------|-------------------|-------------------|-------------------|
| 120 μF ≤ C | Correction factor | 0.40 | 0.50 | 0.60 | 0.65 |

| Rated capacitance (C) | Frequency (f) | 5 kHz ≤ f < 10 kHz | 10 kHz ≤ f < 15 kHz | 15 kHz ≤ f < 20 kHz | 20 kHz ≤ f < 30 kHz |
|-----------------------|-------------------|--------------------|---------------------|---------------------|---------------------|
| 120 μF ≤ C | Correction factor | 0.70 | 0.75 | 0.80 | 0.85 |

| Rated capacitance (C) | Frequency (f) | 30 kHz ≤ f < 50 kHz | 50 kHz ≤ f < 100 kHz | 100 kHz ≤ f < 500 kHz | 500 kHz ≤ f < 1000 kHz |
|-----------------------|-------------------|---------------------|----------------------|-----------------------|------------------------|
| 120 μF ≤ C | Correction factor | 0.85 | 0.90 | 1.00 | 1.00 |

**Conductive Polymer Hybrid Aluminum
Electrolytic Capacitors**
Radial Lead Type
ZE-A series



Features

- Endurance : 2000 h at 145 °C (High temperature / Long life)
- Taping products for automatic insertion
- AEC-Q200 compliant
- RoHS compliant

Specifications

| Size code | F | G |
|------------------------------|--|----------------------------------|
| Category temp. range | -55 °C to +145 °C | |
| Rated voltage range | 25 V to 63 V | |
| Nominal capacitance range | 33 µF to 220 µF | 56 µF to 330 µF |
| Capacitance tolerance | ±20 % (120 Hz / +20°C) | |
| Leakage current | I ≤ 0.01 CV (µA), 2 minutes after reaching rated voltage, 20 °C *CV = (Capacitance in µF) x (Rated voltage in V) | |
| Dissipation factor (tan δ) | Please see the attached characteristics list | |
| Surge voltage (V) | Rated voltage × 1.25 (15 °C to 35 °C) | |
| Endurance 1 | +145 °C ± 2 °C, 2000 h, apply the rated ripple current without exceeding the rated voltage. | |
| | Capacitance change | Within ±30% of the initial value |
| | Dissipation factor (tan δ) | ≤ 200 % of the initial limit |
| | ESR | ≤ 200 % of the initial limit |
| Endurance 2 | +135 °C ± 2 °C, 4000 h, apply the rated ripple current without exceeding the rated voltage. | |
| | Capacitance change | Within ±30% of the initial value |
| | Dissipation factor (tan δ) | ≤ 200 % of the initial limit |
| | ESR | ≤ 300 % of the initial limit |
| Shelf life | After storage for 1000 hours at +145 °C ± 2 °C with no voltage applied and then being stabilized at +20 °C, capacitors shall meet the limits specified in endurance. (Capacitors are left at room temperature and humidity for 2 hours after the test. Then, apply the rated voltage for 30min with a series protection resistance of 1000 Ω ± 10 Ω. Measure electrical characteristics after discharging the capacitor.) | |
| | +85 °C ± 2 °C, 85 % to 90 %RH, 2000 h, rated voltage applied | |
| Damp heat (Load) | Capacitance change | |
| | Dissipation factor (tan δ) | |
| | ESR | |
| | Leakage current | |
| Resistance to soldering heat | After flow soldering and then being stabilized at +20 °C, capacitors shall meet the following limits. | |
| | Capacitance change | |
| | Dissipation factor (tan δ) | |
| | Leakage current | |

Marking

Example : 25 V 220 µF
Marking color : BLACK

Negative polarity marking (-)

Capacitance (µF)

Series identification

Rated voltage code

Lot number

| R.voltage code | Unit : V |
|----------------|----------|
| E | 25 |
| V | 35 |
| H | 50 |
| J | 63 |

Dimensions (not to scale)

| Size code | øD | L | ød | F | P1 |
|-----------|------|-----|-----|----------|-----------|
| F | 8.0 | 9.5 | 0.6 | 3.5±0.5 | 4.60±0.50 |
| G | 10.0 | 9.5 | 0.6 | 5.0 ±0.2 | 3.85±0.50 |

Unit : mm

Explanation of part numbers

◆ Part number system e.g.: EEHAZE1E221B

| EEHA | ZE | | 1E | | 221 | | B | | | |
|------------------------|--------|------|-------------------|-------|------------------|------|------------------|------|-----------------|------|
| Product classification | Series | Code | Rated voltage (V) | Code* | Capacitance (μF) | Code | Capacitance (μF) | Code | Lead space (mm) | Code |
| | ZE | ZE | 25 | 1E | 33 | 330 | 150 | 151 | 3.5, 5.0 | B |
| | | | 35 | 1V | 56 | 560 | 220 | 221 | | |
| | | | 50 | 1H | 68 | 680 | 270 | 271 | | |
| | | | 63 | 1J | 82 | 820 | 330 | 331 | | |
| | | | | | 100 | 101 | | | | |

*: If the total figures number of the part number exceeds 12 figures, "1" is omitted.

Characteristics list

Endurance 1 : 145 °C 2000 h

Endurance 2 : 135 °C 4000 h

| Rated voltage (V) | Capacitance (±20 %) (μF) | Case size (mm) | | | Size code | Specification | | | | Part number | Min. packaging q'ty (pcs) |
|-------------------|--------------------------|----------------|-----|-----|-----------|---------------------------|-----------------------|------------|---------|--------------|---------------------------|
| | | øD | L | ød | | Ripple current*1 (mA rms) | | ESR*2 (mΩ) | tan δ*3 | | Taping |
| | | | | | | Endurance 1 (+145 °C) | Endurance 2 (+135 °C) | | | | |
| 25 | 220 | 8.0 | 9.5 | 0.6 | F | 700 | 1600 | 27 | 0.14 | EEHAZE1E221B | 1000 |
| | 330 | 10.0 | 9.5 | 0.6 | G | 900 | 2000 | 20 | 0.14 | EEHAZE1E331B | 500 |
| 35 | 150 | 8.0 | 9.5 | 0.6 | F | 700 | 1600 | 27 | 0.12 | EEHAZE1V151B | 1000 |
| | 270 | 10.0 | 9.5 | 0.6 | G | 900 | 2000 | 20 | 0.12 | EEHAZE1V271B | 500 |
| 50 | 68 | 8.0 | 9.5 | 0.6 | F | 600 | 1250 | 30 | 0.10 | EEHAZE1H680B | 1000 |
| | 100 | 10.0 | 9.5 | 0.6 | G | 800 | 1600 | 28 | 0.10 | EEHAZE1H101B | 500 |
| 63 | 33 | 8.0 | 9.5 | 0.6 | F | 600 | 1100 | 40 | 0.08 | EEHAZE1J330B | 1000 |
| | 56 | 10.0 | 9.5 | 0.6 | G | 800 | 1400 | 30 | 0.08 | EEHAZE1J560B | 500 |
| | 82 | 10.0 | 9.5 | 0.6 | G | 800 | 1400 | 30 | 0.08 | EEHAZE1J820B | 500 |

*1: Ripple current (100 kHz / +145 °C or +135 °C)

*2: ESR (100 kHz / +20 °C)

*3: tan δ (120 Hz / +20 °C)

◆ Please refer to the page of "Flow soldering profile" and "The taping dimensions".

Frequency correction factor for ripple current

| Rated capacitance (C) | Frequency (f) | 100 Hz ≤ f < 200 Hz | 200 Hz ≤ f < 300 Hz | 300 Hz ≤ f < 500 Hz | 500 Hz ≤ f < 1 kHz |
|-----------------------|-------------------|---------------------|----------------------|-----------------------|------------------------|
| C < 47 μF | Correction factor | 0.10 | 0.10 | 0.15 | 0.20 |
| 47 μF ≤ C < 150 μF | | 0.15 | 0.20 | 0.25 | 0.30 |
| 150 μF ≤ C | | 0.15 | 0.25 | 0.25 | 0.30 |
| Rated capacitance (C) | Frequency (f) | 1 kHz ≤ f < 2 kHz | 2 kHz ≤ f < 3 kHz | 3 kHz ≤ f < 5 kHz | 5 kHz ≤ f < 10 kHz |
| C < 47 μF | Correction factor | 0.30 | 0.40 | 0.45 | 0.50 |
| 47 μF ≤ C < 150 μF | | 0.40 | 0.45 | 0.55 | 0.60 |
| 150 μF ≤ C | | 0.45 | 0.50 | 0.60 | 0.65 |
| Rated capacitance (C) | Frequency (f) | 10 kHz ≤ f < 15 kHz | 15 kHz ≤ f < 20 kHz | 20 kHz ≤ f < 30 kHz | 30 kHz ≤ f < 40 kHz |
| C < 47 μF | Correction factor | 0.60 | 0.65 | 0.70 | 0.75 |
| 47 μF ≤ C < 150 μF | | 0.70 | 0.75 | 0.80 | 0.80 |
| 150 μF ≤ C | | 0.75 | 0.80 | 0.85 | 0.85 |
| Rated capacitance (C) | Frequency (f) | 40 kHz ≤ f < 50 kHz | 50 kHz ≤ f < 100 kHz | 100 kHz ≤ f < 500 kHz | 500 kHz ≤ f < 1000 kHz |
| C < 47 μF | Correction factor | 0.80 | 0.85 | 1.00 | 1.05 |
| 47 μF ≤ C < 150 μF | | 0.85 | 0.90 | 1.00 | 1.00 |
| 150 μF ≤ C | | 0.85 | 0.90 | 1.00 | 1.00 |

After endurance ESR (100 kHz, -40 °C)

| Size code | F (ø8 x L9.5) | G (ø10 x L9.5) |
|-----------|---------------|----------------|
| ESR (Ω) | 0.4 | 0.3 |

**Conductive Polymer Hybrid Aluminum
Electrolytic Capacitors**
Radial Lead Type
ZF-A series

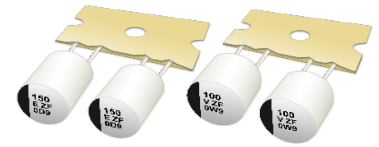

Features

- Endurance : 1000 h at 150 °C (High temperature)
- High temperature compared with ZC series
- High-withstand voltage (to 63 V)
- Characteristics dependencies in frequency and low temperature are as small as polymer type
- Compatible with taping products for automatic insertion
- AEC-Q200 compliant
- RoHS compliant

Specifications

| Size code | F | G |
|---|--|----------------------------------|
| Category temp. range | -55 °C to +150 °C | |
| Rated voltage range | 25 V to 63 V | |
| Nominal capacitance range | 33 µF to 150 µF | 56 µF to 270 µF |
| Capacitance tolerance | ±20 % (120 Hz / +20°C) | |
| Leakage current | I ≤ 0.01 CV (µA), 2 minutes after reaching rated voltage, 20 °C *CV = (Capacitance in µF) x (Rated voltage in V) | |
| Dissipation factor (tan δ) | Please see the attached characteristics list | |
| Surge voltage (V) | Rated voltage × 1.25 (15 °C to 35 °C) | |
| Endurance | +150 °C ± 2 °C, 1000 h, apply the rated ripple current without exceeding the rated voltage. | |
| | Capacitance change | Within ±30% of the initial value |
| | Dissipation factor (tan δ) | ≤ 200 % of the initial limit |
| | ESR | ≤ 200 % of the initial limit |
| | Leakage current | Within the initial limit |
| ESR after endurance (Ω / 100 kHz)(-40 °C) | Size code | |
| | F | G |
| Shelf life | After storage for 1000 hours at +150 °C ± 2 °C with no voltage applied and then being stabilized at +20 °C, capacitors shall meet the limits specified in endurance. (Capacitors are left at room temperature and humidity for 2 hours after the test. Then, apply the rated voltage for 30min with a series protection resistance of 1000 Ω ± 10 Ω. Measure electrical characteristics after discharging the capacitor.) | |
| | +85 °C ± 2 °C, 85 % to 90 %RH, 2000 h, rated voltage applied | |
| Damp heat (Load) | Capacitance change | Within ±30% of the initial value |
| | Dissipation factor (tan δ) | ≤ 200 % of the initial limit |
| | ESR | ≤ 200 % of the initial limit |
| | Leakage current | Within the initial limit |
| Resistance to soldering heat | After flow soldering and then being stabilized at +20 °C, capacitors shall meet the following limits. | |
| | Capacitance change | Within ±10% of the initial value |
| | Dissipation factor (tan δ) | Within the initial limit |
| | Leakage current | Within the initial limit |

Marking

Example : 25 V 150 µF
Marking color : BLACK

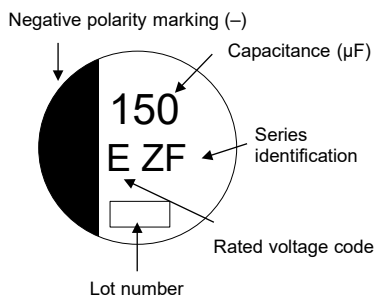

| R. voltage code | Unit : V |
|-----------------|----------|
| E | 25 |
| V | 35 |
| H | 50 |
| J | 63 |

Dimensions (not to scale)

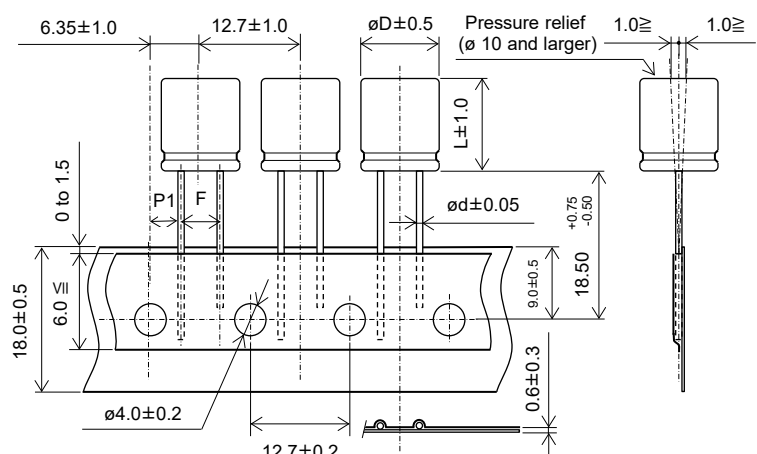

| Size code | øD | L | ød | F | P1 |
|-----------|------|-----|-----|-------------------------------------|-----------|
| F | 8.0 | 9.5 | 0.6 | 3.5±0.5 | 4.60±0.50 |
| G | 10.0 | 9.5 | 0.6 | 5.0 ^{+0.8} _{-0.5} | 3.85±0.50 |

Unit : mm

Explanation of part numbers

◆ Part number system e.g.: EEHAZF1E151B

| EEHA | ZF | | 1E | | 151 | | B | | | |
|------------------------|--------|------|-------------------|-------|------------------|------|------------------|------|-----------------|------|
| Product classification | Series | Code | Rated voltage (V) | Code* | Capacitance (μF) | Code | Capacitance (μF) | Code | Lead space (mm) | Code |
| | ZF | ZF | 25 | 1E | 33 | 330 | 150 | 151 | 3.5, 5.0 | B |
| | | | 35 | 1V | 56 | 560 | 270 | 271 | | |
| | | | 50 | 1H | 100 | 101 | | | | |
| | | | 63 | 1J | | | | | | |

*: If the total figures number of the part number exceeds 12 figures, "1" is omitted.

Characteristics list

Endurance : 150 °C 1000 h

| Rated voltage (V) | Capacitance (±20 %) (μF) | Case size (mm) | | | Size code | Specification | | | Part number | Min. packaging q'ty (pcs) |
|-------------------|--------------------------|----------------|-----|-----|-----------|---------------------------------------|------------------------|---------------------|--------------|---------------------------|
| | | øD | L | ød | | Ripple current ^{*1} (mA rms) | ESR ^{*2} (mΩ) | tan δ ^{*3} | | Taping |
| 25 | 150 | 8.0 | 9.5 | 0.6 | F | 800 | 27 | 0.14 | EEHAZF1E151B | 1000 |
| | 270 | 10.0 | 9.5 | 0.6 | G | 1000 | 20 | 0.14 | EEHAZF1E271B | 500 |
| 35 | 100 | 8.0 | 9.5 | 0.6 | F | 770 | 30 | 0.12 | EEHAZF1V101B | 1000 |
| | 150 | 10.0 | 9.5 | 0.6 | G | 950 | 23 | 0.12 | EEHAZF1V151B | 500 |
| 50 | 56 | 8.0 | 9.5 | 0.6 | F | 700 | 35 | 0.10 | EEHAZF1H560B | 1000 |
| | 100 | 10.0 | 9.5 | 0.6 | G | 900 | 28 | 0.10 | EEHAZF1H101B | 500 |
| 63 | 33 | 8.0 | 9.5 | 0.6 | F | 650 | 40 | 0.08 | EEHAZF1J330B | 1000 |
| | 56 | 10.0 | 9.5 | 0.6 | G | 840 | 30 | 0.08 | EEHAZF1J560B | 500 |

*1: Ripple current (100 kHz / +150 °C)

*2: ESR (100 kHz / +20 °C)

*3: tan δ (120 Hz / +20 °C)

◆ Please refer to the page of "Flow soldering profile" and "The taping dimensions".

Frequency correction factor for ripple current

| Rated capacitance (C) | Frequency (f) | 100 Hz ≤ f < 200 Hz | 200 Hz ≤ f < 300 Hz | 300 Hz ≤ f < 500 Hz | 500 Hz ≤ f < 1 kHz |
|-----------------------|-------------------|---------------------|----------------------|-----------------------|---------------------|
| C < 47 μF | Correction factor | 0.10 | 0.10 | 0.15 | 0.20 |
| 47 μF ≤ C < 150 μF | | 0.15 | 0.20 | 0.25 | 0.30 |
| 150 μF ≤ C | | 0.15 | 0.25 | 0.25 | 0.30 |
| Rated capacitance (C) | Frequency (f) | 1 kHz ≤ f < 2 kHz | 2 kHz ≤ f < 3 kHz | 3 kHz ≤ f < 5 kHz | 5 kHz ≤ f < 10 kHz |
| C < 47 μF | Correction factor | 0.30 | 0.40 | 0.45 | 0.50 |
| 47 μF ≤ C < 150 μF | | 0.40 | 0.45 | 0.55 | 0.60 |
| 150 μF ≤ C | | 0.45 | 0.50 | 0.60 | 0.65 |
| Rated capacitance (C) | Frequency (f) | 10 kHz ≤ f < 15 kHz | 15 kHz ≤ f < 20 kHz | 20 kHz ≤ f < 30 kHz | 30 kHz ≤ f < 40 kHz |
| C < 47 μF | Correction factor | 0.60 | 0.65 | 0.70 | 0.75 |
| 47 μF ≤ C < 150 μF | | 0.70 | 0.75 | 0.80 | 0.80 |
| 150 μF ≤ C | | 0.75 | 0.80 | 0.85 | 0.85 |
| Rated capacitance (C) | Frequency (f) | 40 kHz ≤ f < 50 kHz | 50 kHz ≤ f < 100 kHz | 100 kHz ≤ f < 500 kHz | 500 kHz ≤ f |
| C < 47 μF | Correction factor | 0.80 | 0.85 | 1.00 | 1.05 |
| 47 μF ≤ C < 150 μF | | 0.85 | 0.90 | 1.00 | 1.00 |
| 150 μF ≤ C | | 0.85 | 0.90 | 1.00 | 1.00 |

Safety Precautions

When using our products, no matter what sort of equipment they might be used for, be sure to confirm the applications and environmental conditions with our specifications in advance.

Panasonic
INDUSTRY

Panasonic Industry Co., Ltd.
Device Solutions Business Division

1006 Kadoma, Kadoma City, Osaka
571-8506 Japan