

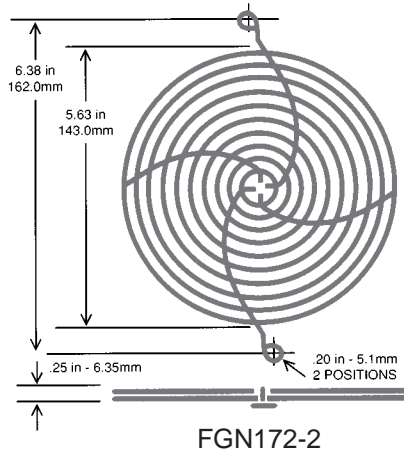

Cooling Fan Accessories: Single-source convenience and procurement cost control

ETRI, Inc., a leader in the design and production of AC and DC cooling fans, also offers a complete line of wire form fan guards, plastic fan filter assemblies and fan power cords. As a single source supplier of both fans and critical accessories, ETRI helps you streamline purchasing and control your procurement costs.

ETRI maintains a significant inventory of fan accessories to ensure that your orders are shipped promptly. Like ETRI cooling fans, ETRI fan accessories are designed and produced using only the most advanced methods and materials. Our goal is to provide our customers the high-quality products and the high-quality service they expect and deserve.

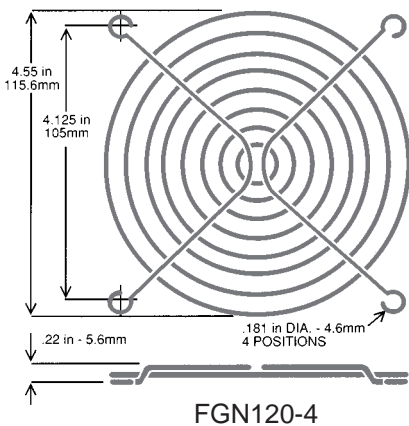
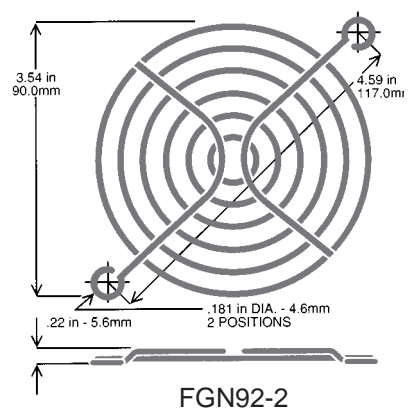
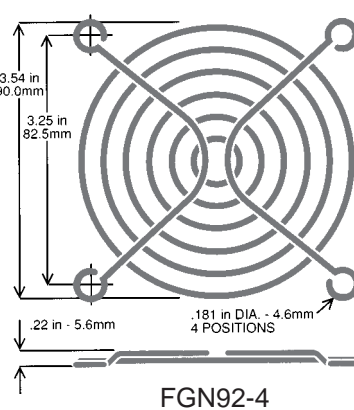
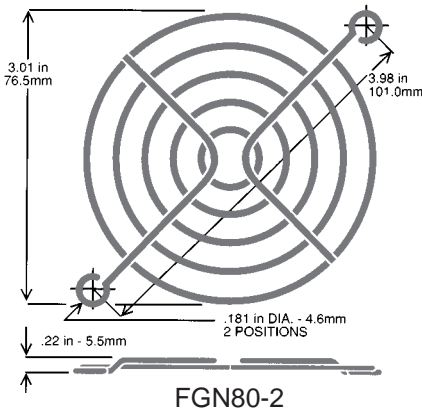
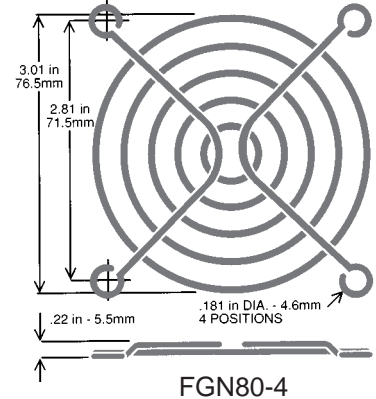
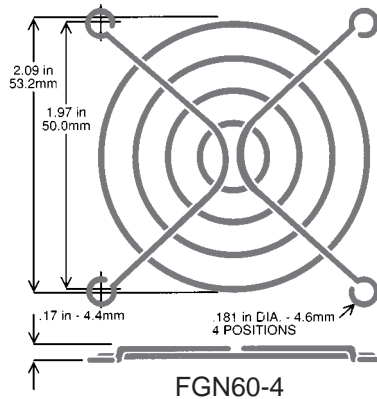
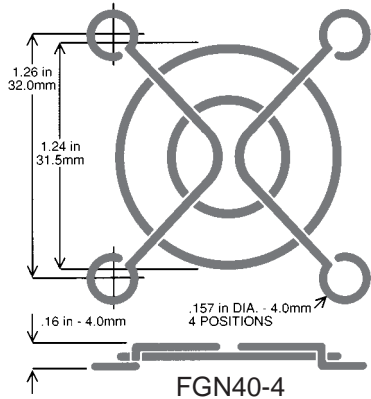

WIRE FORM FINGER GUARDS

Durable finger guards ensure safe fan operation in situations that require customer protection. Our guards are made from sturdy 0.060" ribs and have bright nickel-chrome finish. Industry standard mounting centers allow use in both new designs and retrofit applications. All guard designs meet UL spacing requirements.

Part Number	Description	Fits	Finish	General Specifications
FGN40-4	Fingerguard	40mm	Nickel chrome	<ul style="list-style-type: none"> Meets UL/CSA requirements Plating: bright nickel chrome .0005 minimum thickness Weld joints withstand 230 lbs. separation force Wire: C1010 Steel
FGN60-4	Fingerguard	60mm	Nickel chrome	
FGN80-4	Fingerguard	80mm	Nickel chrome	
FGN80-2	Fingerguard	80mm	Nickel chrome	
FGN92-4	Fingerguard	92mm	Nickel chrome	
FGN92-2	Fingerguard	92mm	Nickel chrome	
FGN120-4	Fingerguard	120mm	Nickel chrome	
FGN172-2	Fingerguard	172mm	Nickel chrome	