

## Data Sheet | Item Number: 2706-208

PCB terminal block; lever; 6 mm<sup>2</sup>; Pin spacing 10 mm; 8-pole; CAGE CLAMP®; gray

<https://www.wago.com/2706-208>



Color: ■ gray

Similar to illustration

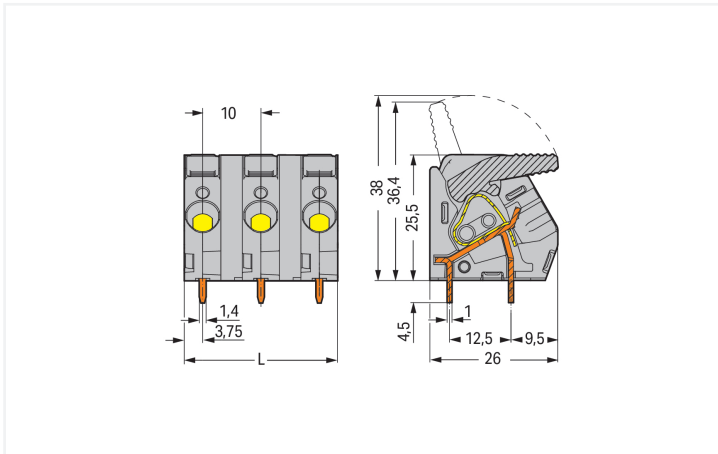
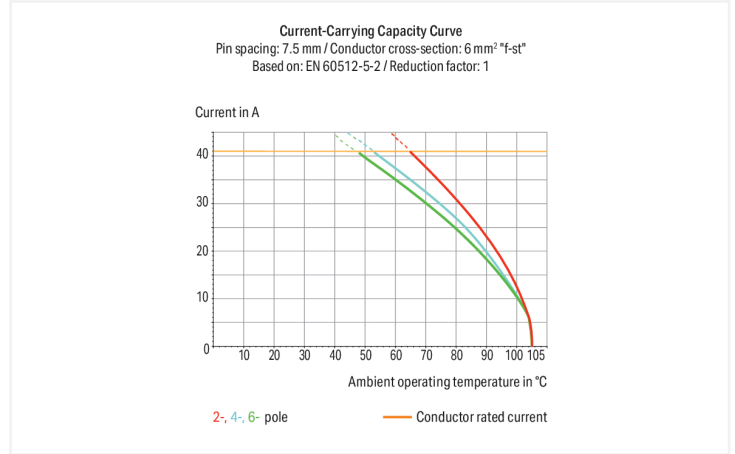

Dimensions in mm

L = (pole no. x pin spacing) – 2.5 mm

PCB terminal block, 2706 Series, 30° conductor entry to board

Quick and easy connections are guaranteed with this PCB terminal block (item number 2706-208). It is a universal connector that can be used almost anywhere, e.g., as a pluggable PCB connector, panel feedthrough header, connector for rail-mount terminal blocks, or a floating connector for different mounting methods. Strip lengths must be between 11 and 12 mm when connecting conductors to this PCB terminal block. This product features one conductor terminal and utilizes CAGE CLAMP®. Our renowned universal connection known as CAGE CLAMP® leads the way when it comes to connection technology and electrical interconnections. Dimensions: (75 x 30 x 26) mm (width x height x depth). Depending on the type of conductor, this PCB terminal block is ideal for conductor cross sections ranging from 0.5 mm<sup>2</sup> to 6 mm<sup>2</sup>.

Tin is used for coating the contact surfaces. This PCB terminal block is operated with a lever. THT is used to assemble the PCB terminal block. Insert the conductor into the board at an angle of 30°..

## Notes

Variants:	Other pole numbers Other colors Mixed-color PCB connector strips Direct marking Other versions (or variants) can be requested from WAGO Sales or configured at <a href="https://configurator.wago.com/">https://configurator.wago.com/</a> .
-----------	--

## Electrical data

Ratings per	IEC/EN 60664-1			Approvals per	UL 1059		
Overtoltage category	III	III	II	Use group	B	C	D
Pollution degree	3	2	2	Rated voltage	300 V	150 V	600 V
Nominal voltage	800 V	1000 V	1000 V	Rated current	30 A	30 A	5 A
Rated impulse withstand voltage	8 kV	8 kV	8 kV				
Rated current	41 A	41 A	41 A				

## Connection Data

Clamping units	8	<b>Connection 1</b>	
Total number of potentials	8	Connection technology	CAGE CLAMP®
Number of connection types	1	Actuation type	Lever
Number of levels	1	Solid conductor	0.5 ... 6 mm <sup>2</sup> / 20 ... 10 AWG
		Fine-stranded conductor	0.5 ... 6 mm <sup>2</sup> / 20 ... 10 AWG
		Fine-stranded conductor; with insulated ferrule	0.5 ... 6 mm <sup>2</sup>
		Fine-stranded conductor; with uninsulated ferrule	0.5 ... 6 mm <sup>2</sup>
		Strip length	11 ... 12 mm / 0.43 ... 0.47 inches
		Conductor connection direction to PCB	30°
		Pole number	8

## Physical data

Pin spacing	10 mm / 0.394 inches
Width	75 mm / 2.953 inches
Height	30 mm / 1.181 inches
Height from the surface	25.5 mm / 1.004 inches
Depth	26 mm / 1.024 inches
Solder pin length	4.5 mm
Solder pin dimensions	1 x 1.4 mm
Drilled hole diameter	1.8 (+0.1) mm

## PCB contact

PCB contact	THT
Solder pin arrangement	over the entire terminal strip (in-line)
Number of solder pins per potential	2

### Material data

Note (material data)	<a href="#">Information on material specifications can be found here</a>
Color	gray
Material group	I
Insulation material (main housing)	Polyamide (PA66)
Flammability class per UL94	V0
Clamping spring material	Chrome-nickel spring steel (CrNi)
Contact material	Electrolytic copper (E <sub>Cu</sub> )
Contact Plating	Tin
Fire load	0.822 MJ
Weight	48.2 g

### Environmental requirements

Limit temperature range	-60 ... +105 °C
-------------------------	-----------------

### Commercial data

Product Group	4 (Printed Circuit Connectors)
PU (SPU)	15 pcs
Packaging type	Box
Country of origin	PL
GTIN	4050821093282
Customs tariff number	85369010000

### Product Classification

UNSPSC	39121409
eCl@ss 10.0	27-44-04-01
eCl@ss 9.0	27-44-04-01
ETIM 9.0	EC002643
ETIM 10.0	EC002643
ECCN	NO US CLASSIFICATION

### Environmental Product Compliance

RoHS Compliance Status	Compliant, No Exemption
------------------------	-------------------------

### Approvals / Certificates

#### General approvals



Approval	Standard	Certificate Name
CCA DEKRA Certification B.V.	EN 60947	2143801.01
CCA DEKRA Certification B.V.	EN 60947-7-4	NTR NL-7869
CSA DEKRA Certification B.V.	C22.2 No. 158	2516072
UL UL International Germany GmbH	UL 1059	E45172

#### Declarations of conformity and manufacturer's declarations

Approval	Standard	Certificate Name
EU-Declaration of Conformity WAGO GmbH & Co. KG	-	-
UK-Declaration of Conformity WAGO GmbH & Co. KG	-	-

**Downloads**

**Environmental Product Compliance**

**Compliance Search**

Environmental Product Compliance 2706-208



**Documentation**

**Additional Information**

Technical Section

03.04.2019

pdf

2027.26 KB



**CAD/CAE-Data**

**CAD data**

2D/3D Models 2706-208



**CAE data**

ZUKEN Portal 2706-208



**PCB Design**

Symbol and Footprint via SamacSys 2706-208



Symbol and Footprint via Ultra Librarian 2706-208



**1 Compatible Products**

**1.1 Optional Accessories**

**1.1.1 Ferrule**

**1.1.1.1 Ferrule**



**Item No.: 216-262**

Ferrule; Sleeve for 0.75 mm<sup>2</sup> / 18 AWG; insulated; electro-tin plated; electrolytic copper; gastight crimped; acc. to DIN 46228, Part 4/09.90; gray



**Item No.: 216-263**

Ferrule; Sleeve for 1 mm<sup>2</sup> / AWG 18; insulated; electro-tin plated; electrolytic copper; gastight crimped; acc. to DIN 46228, Part 4/09.90; red



**Item No.: 216-264**

Ferrule; Sleeve for 1.5 mm<sup>2</sup> / AWG 16; insulated; electro-tin plated; electrolytic copper; gastight crimped; acc. to DIN 46228, Part 4/09.90; black



**Item No.: 216-266**

Ferrule; Sleeve for 2.5 mm<sup>2</sup> / AWG 14; insulated; electro-tin plated; electrolytic copper; gastight crimped; acc. to DIN 46228, Part 4/09.90; blue



**Item No.: 216-267**

Ferrule; Sleeve for 4 mm<sup>2</sup> / AWG 12; insulated; electro-tin plated; electrolytic copper; gastight crimped; acc. to DIN 46228, Part 4/09.90; gray



**Item No.: 216-208**

Ferrule; Sleeve for 6 mm<sup>2</sup> / AWG 10; insulated; electro-tin plated; electrolytic copper; gastight crimped; acc. to DIN 46228, Part 4/09.90; yellow



**Item No.: 216-108**

Ferrule; Sleeve for 6 mm<sup>2</sup> / AWG 10; uninsulated; electro-tin plated; silver-colored

## 1.1.2 Test and measurement

### 1.1.2.1 Testing accessories



**Item No.: 210-136**

Test plug; 2 mm Ø; with 500 mm cable; red

## Installation Notes

### Conductor termination

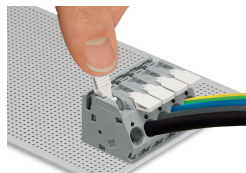

To open the clamping unit, pull the operating lever all the way back – 2706 and 2716 Series.

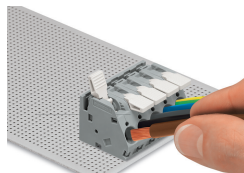

Inserting/removing a conductor – 2706 and 2716 Series.

## Testing

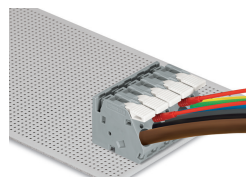

Testing with test plug – 2706 and 2716 Series.