

# PRODUCT DATA DRAWING

REVISION HISTORY			
REV	DESCRIPTION	DATE	APPROVED
A	DCN 55723	11/24	SEE PDM

## RECOMMENDED MOUNTING HOLE

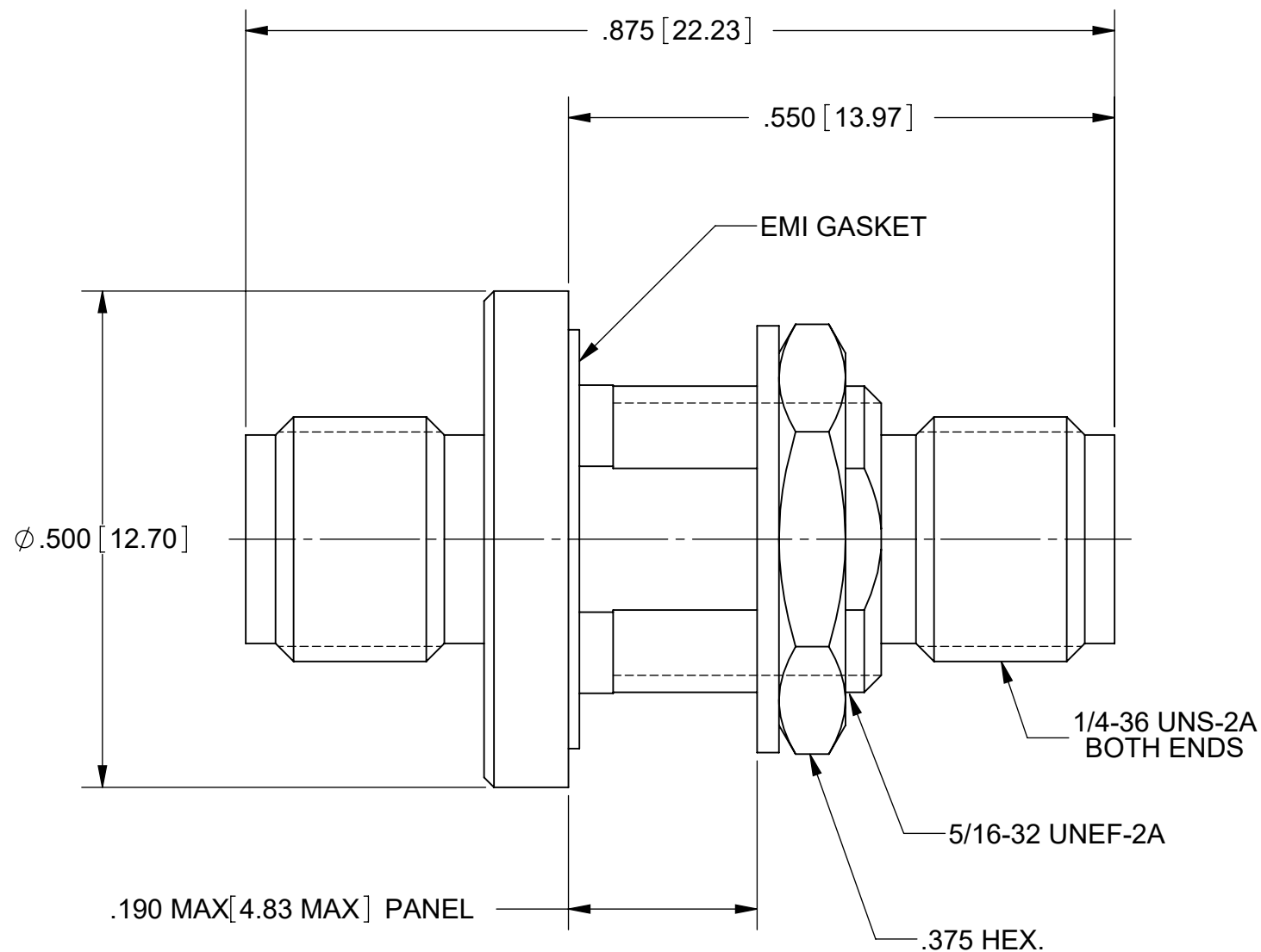
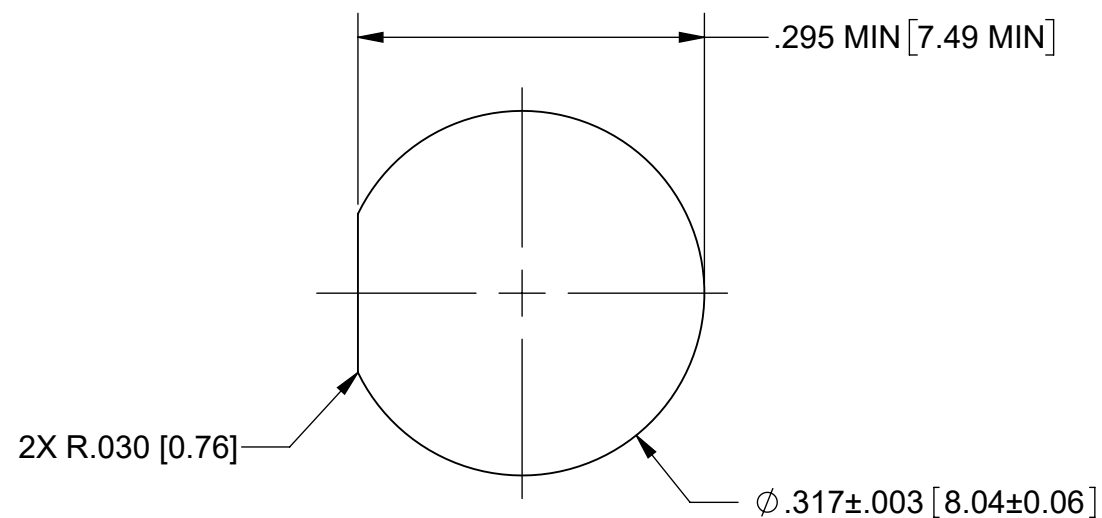

### MATERIAL:

BODY,  
HEX NUT &  
LOCKWASHER:

STAINLESS STEEL PER AMS-5640,  
ALLOY UNS S30300, TYPE 1

CONTACT:

BERYLLIUM COPPER PER ASTM B196,  
ALLOY No. UNS C17300, TD04

INSULATOR:

PTFE PER ASTM D1710, TYPE I, GRADE 1, CLASS B

EMI GASKET:

CONDUCTIVE SILVER OR SILVER PLATED  
COPPER/SILICONE ELASTOMER

### FINISH:

BODY,  
HEX NUT &  
LOCKWASHER:

PASSIVATED PER AMS-2700

CONTACT:

GOLD PER ASTM B488, TYPE II,  
CODE C, CLASS 1.27, OVER NICKEL  
PER AMS-QQ-N-290, CLASS 1, .00005" MIN.

### PERFORMANCE:

IMPEDANCE:  
FREQ. RANGE:  
INSERTION LOSS:  
APPROX. MASS:

50 OHMS  
DC TO 18.0 GHz  
.04dB X SQRT(F IN GHz)  
6.4 GRAMS

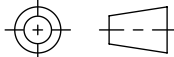
MATERIAL: SEE NOTES	DIMENSIONS ARE IN INCHES TOLERANCES: FRACTIONAL: ±1/64 ANGULAR: X° ±1'0" X'X' ±15'	UNLESS OTHERWISE SPECIFIED 1) ALL DIMENSIONS ARE IN INCHES (MILLIMETERS) 2) ALL DIMENSIONS ARE AFTER PLATING. 3) BREAK CORNERS & EDGES .005 R. MAX. 4) CHAM. 1ST & LAST THREADS. 5) SURFACE ROUGHNESS 63-MIL-STD-10. 6) DIA.'S ON COMMON CENTERS TO BE CONCENTRIC WITHIN .005 T.I.R. 7) REMOVE ALL BURRS	 www.svmicrowave.com TITLE: SMA F TO SMA F STR. ADAPTER
FINISH: SEE NOTES	DECIMAL: X ±.030 .XX ±.010 .XXX ±.005	INTERPRET DIMENSIONS AND TOLERANCES PER ASME Y14.5M - 1994	
SURFACE AREA: N/A	THIRD ANGLE PROJECTION	DRAWN: TSW 04/26/21	SIZE DWG. NO. 1129-6279
PROPRIETARY THE INFORMATION CONTAINED IN THIS DRAWING IS THE SOLE PROPERTY OF SV MICROWAVE, INC. ANY REPRODUCTION IN PART OR AS A WHOLE WITHOUT THE WRITTEN PERMISSION OF SV MICROWAVE, INC IS PROHIBITED.		CHECKED: SEE PDM	SCALE: 6:1
		APPROVED: SEE PDM	SHEET 1 OF 1