

Long Life Potentiometer - 500 000 Cycles Miniature - Cermet - Fully Sealed

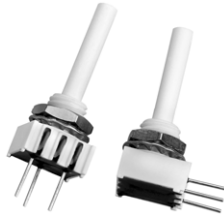

FEATURES

- 500 000 cycles
- Cermet element
- Low temperature coefficient (± 150 ppm/ $^{\circ}$ C typical)
- Plastic housing and shaft
- Compact (3/8" square)
- Fully sealed
- Test according to CECC 41000 or IEC 60393-1
- Material categorization: for definitions of compliance please see www.vishay.com/doc?99912



RoHS
COMPLIANT

QUICK REFERENCE DATA

Multiple module	No
Switch module	n/a
Detent module	n/a
Special electrical laws	No, only A: linear
Sealing level	IP 67
Lifespan	500K cycles

DIMENSIONS in millimeters (inches) ± 0.5 mm (± 0.02 ")

P10L: Side Adjust

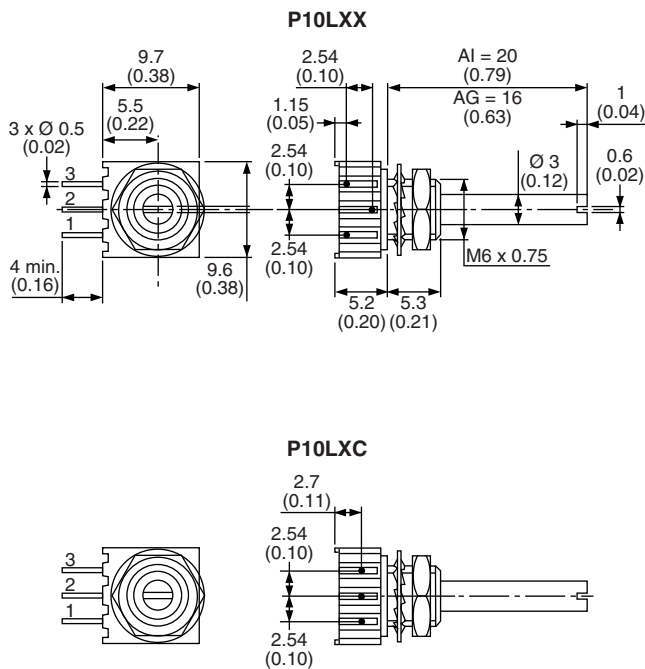

P10L: Top Adjust

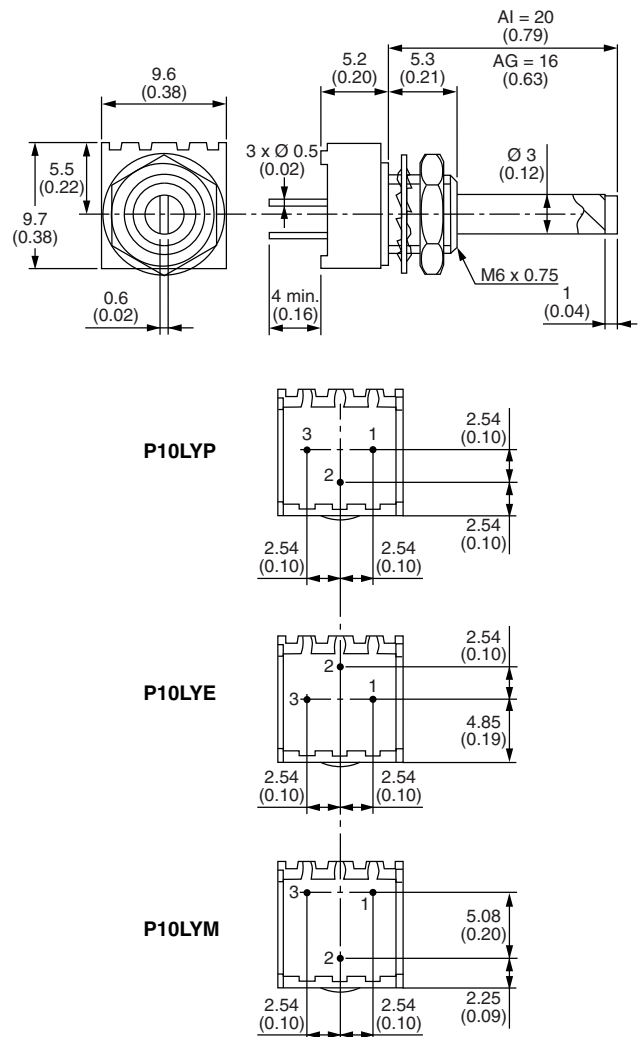

ELECTRICAL SPECIFICATIONS																
Resistive element	Cermet															
Electrical travel	250° ± 15°															
Standard resistance values	1 kΩ - 5 kΩ - 10 kΩ - 50 kΩ															
Tolerance	20 % - 10 % on request															
Taper	Linear A															
Circuit diagram																
Power rating	0.1 W at 70 °C 															
Standard resistance element data	<table border="1"> <thead> <tr> <th>Resistance Value (kΩ)</th> <th>Max. Power at 70 °C (W)</th> <th>Max. Working Voltage (V)</th> </tr> </thead> <tbody> <tr> <td>1</td> <td>0.1</td> <td>10</td> </tr> <tr> <td>5</td> <td>0.1</td> <td>22.3</td> </tr> <tr> <td>10</td> <td>0.1</td> <td>31.6</td> </tr> <tr> <td>50</td> <td>0.1</td> <td>70.7</td> </tr> </tbody> </table>	Resistance Value (kΩ)	Max. Power at 70 °C (W)	Max. Working Voltage (V)	1	0.1	10	5	0.1	22.3	10	0.1	31.6	50	0.1	70.7
Resistance Value (kΩ)	Max. Power at 70 °C (W)	Max. Working Voltage (V)														
1	0.1	10														
5	0.1	22.3														
10	0.1	31.6														
50	0.1	70.7														
Temperature coefficient (typical)	± 150 ppm/°C															
Limiting element voltage	75 V															
End resistance (typical)	1 Ω															
Dielectric strength (RMS)	1000 V															
Insulation resistance (300 V _{DC})	10 ⁶ MΩ															
Independent linearity (typical)	± 5 %															

MECHANICAL SPECIFICATIONS		
Mechanical travel	290° ± 5	
Operating torque (typical)	2 Ncm max.	2.83 oz.-inch max.
End stop torque	7 Ncm max.	9.9 oz.-inch max.
Tightening torque of mounting nut	25 Ncm max.	2.2 lb.-inch max.
Unit weight	1 g	3.5 10 ⁻² oz.
Terminals	e3: Pure Sn	

ENVIRONMENTAL SPECIFICATIONS	
Temperature range	-40 °C to +100 °C
Climatic category	40/100/56
Sealing	Fully sealed - container IP67

MARKING
<ul style="list-style-type: none"> • Vishay trademark • Model • Ohmic value code • Tolerance code • Manufacturing date code • Marking of terminals 3

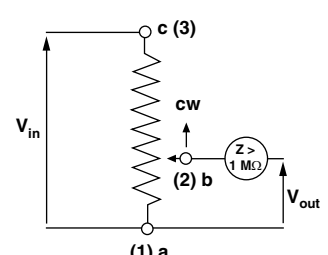
APPLICATION NOTE	
<p>The potentiometer shall be used in voltage divider with an impedance load at least 100 times higher than the total potentiometer nominal resistance value.</p> <p>Advised load impedance: 1 MΩ min. for resistance range of 1kΩ to 50 kΩ</p>	

PERFORMANCE				
TESTS	CONDITIONS	TYPICAL VALUES AND DRIFTS		
		$\Delta R_T/R_T$ (%)	$\Delta R_{1-2}/R_{1-2}$ (%)	OTHER
Electrical endurance	1000 h at rated power 90°/30° - ambient temp. 70 °C	± 20 %	± 20 %	-
Climatic sequence	Phase A dry heat 100 °C Phase B damp heat Phase C cold -40 °C Phase D damp heat 5 cycles	± 1 %	± 2 %	-
Damp heat, steady state	56 days 40 °C 93 % HR	± 1 %	± 2 %	Insulation resistance: > 10 ⁴ MΩ
Change of temperature	5 cycles -40 °C at 100 °C	± 1 %	± 2 %	-
Mechanical endurance	500 000 cycles at rated power Turn angle: ± 50° Temperature: 20 °C	± 20 %	-	Independent linearity: ± 20 %
Shock	50 g's at 11 ms 3 successive shocks in 3 directions	± 0.5 %	± 1 %	-
Vibration	10 Hz to 55 Hz 0.75 mm or 10 g's during 6 h	± 0.5 %	± 1 %	-

Note

- Nothing stated herein shall be construed as a guarantee of quality or durability



ORDERING INFORMATION (part number)																	
P	1	0	L	X	X	A	G	1	0	2	M	B	4				
MODEL	STYLE			SHAFT		RESISTANCE CODE			TOLERANCE CODE		PACKAGING CODE		SPECIAL NUMBER				
P10L	XC XX YE YM YP			AG = Ø 3 mm to 16 mm AI = Ø 3 mm to 20 mm		102 = 1 kΩ 502 = 5 kΩ 103 = 10 kΩ 503 = 50 kΩ			M = 20 % On request: K = 10 %		B4 = box 100 pieces		(if applicable) Given by Vishay for custom design				

PART NUMBER DESCRIPTION (for information only)							
P10L	XX	AG	1K	20 %		BO100	e3
MODEL	STYLE	SHAFT	VALUE	TOLERANCE	SPECIAL	PACKAGING	LEAD (Pb)-FREE

RELATED DOCUMENTS	
APPLICATION NOTES	
Potentiometers and Trimmers	www.vishay.com/doc?51001
Guidelines for Vishay Sfernice Resistive and Inductive Components	www.vishay.com/doc?52029



Disclaimer

ALL PRODUCT, PRODUCT SPECIFICATIONS AND DATA ARE SUBJECT TO CHANGE WITHOUT NOTICE TO IMPROVE RELIABILITY, FUNCTION OR DESIGN OR OTHERWISE.

Vishay Intertechnology, Inc., its affiliates, agents, and employees, and all persons acting on its or their behalf (collectively, "Vishay"), disclaim any and all liability for any errors, inaccuracies or incompleteness contained in any datasheet or in any other disclosure relating to any product.

Vishay makes no warranty, representation or guarantee regarding the suitability of the products for any particular purpose or the continuing production of any product. To the maximum extent permitted by applicable law, Vishay disclaims (i) any and all liability arising out of the application or use of any product, (ii) any and all liability, including without limitation special, consequential or incidental damages, and (iii) any and all implied warranties, including warranties of fitness for particular purpose, non-infringement and merchantability.

Statements regarding the suitability of products for certain types of applications are based on Vishay's knowledge of typical requirements that are often placed on Vishay products in generic applications. Such statements are not binding statements about the suitability of products for a particular application. It is the customer's responsibility to validate that a particular product with the properties described in the product specification is suitable for use in a particular application. Parameters provided in datasheets and / or specifications may vary in different applications and performance may vary over time. All operating parameters, including typical parameters, must be validated for each customer application by the customer's technical experts. Product specifications do not expand or otherwise modify Vishay's terms and conditions of purchase, including but not limited to the warranty expressed therein.

Hyperlinks included in this datasheet may direct users to third-party websites. These links are provided as a convenience and for informational purposes only. Inclusion of these hyperlinks does not constitute an endorsement or an approval by Vishay of any of the products, services or opinions of the corporation, organization or individual associated with the third-party website. Vishay disclaims any and all liability and bears no responsibility for the accuracy, legality or content of the third-party website or for that of subsequent links.

Except as expressly indicated in writing, Vishay products are not designed for use in medical, life-saving, or life-sustaining applications or for any other application in which the failure of the Vishay product could result in personal injury or death. Customers using or selling Vishay products not expressly indicated for use in such applications do so at their own risk. Please contact authorized Vishay personnel to obtain written terms and conditions regarding products designed for such applications.

No license, express or implied, by estoppel or otherwise, to any intellectual property rights is granted by this document or by any conduct of Vishay. Product names and markings noted herein may be trademarks of their respective owners.