

MPB125 Multiple-Output

AC-DC Power Supplies

The MPB125 Series incorporates patented high efficiency circuitry, high power density and active Power Factor Correction (PFC) to meet the requirements of networking and data communications systems, as well as commercial and industrial configurations.

Dual output units deliver a regulated main output plus a second 12V output for fans or other system functions. Multiple output models provide tightly regulated DC power in a variety of configurations. The MPB125 is rated for convection as well as forced-air cooling.

Full output power is available with as few as 5 Cubic Feet per Minute (CFM) forced-air cooling with the exception of the MPB125-2003DG which need only 10 CFM for full power. Optional remote on/off with standby power is also available.

The MPB125 product line is approved to the latest international regulatory standards and displays the CE Mark.



Key Features & Benefits

- RoHS Lead Free & Lead-Solder-Exempt Products are Available
- High Power Density
- Industry-Standard 3" x 5" Footprint
- Power Factor Correction (PFC) Meets EN 61000-3-2
- Main Output Remote Sense
- Power Good signals
- CE Marked to Low Voltage Directive
- Input Transient & ESD Compliance to EN 61000-4-2/-3/-4/-5
- MTBF In Excess of 1 Million Hours based upon field data
- Optional Remote On/Off with 5V Standby



belfuse.com/power-solutions

Please read our datasheet & drawing disclaimer [here](#).

MULTIPLE OUTPUT MODEL SELECTION

MODEL	OUTPUT VOLTAGE [V]	MAXIMUM OUTPUT CURRENT (AMPS), 130 LFM	TOTAL REGULATION [%]	RIPPLE & NOISE ¹ % pk-pk	REGULATION RANGE
MPB125-2003DG ²	+3.3V	30A	±3%	1%	3.20V to 3.40V
	+12V	0.5A	±5%	1%	11.80V to 12.60V
MPB125-2005G ^{3,4}	+5V	25A	±3%	1%	4.85V to 5.15V
	+12V	0.5A	±5%	1%	10.80V to 12.60V
MPB125-2012 ^{3,4,5}	+12V	10.5A	±3%	1%	11.64V to 12.36V
	12V	0.5A	±5%	1%	11.40V to 12.60V
MPB125-2015 ^{3,4,5}	+15V	8.3A	±3%	1%	14.54V to 15.45V
	12V	0.5A	±5%	1%	11.40V to 12.60V
MPB125-2024G ^{3,4,5}	+24V	5.2A	±3%	1%	23.28V to 24.72V
	12V	0.5A	±5%	1%	11.40V to 12.60V
MPB125-2048 ^{3,4,5}	+48V	2.6A	±3%	1%	46.56V to 49.44V
	12V	0.5A	±5%	1%	11.40V to 12.60V
MPB125-3000 ⁶	+5V	16.5A	±4%	1% ⁸	4.85V to 5.25V
	+12V	5A/9Apk	±5%	1%	11.40V to 12.60V
	-12V	0.5A	±5%	1%	-11.40V to -12.60V
MPB125-4250 ⁶	+2.5V	12A ⁷	±3%	2%	2.42V to 2.58V
	+5V	15A ⁷	±4%	1% ⁸	4.85V to 5.25V
	+12V	5A/9Apk	±5%	1%	11.40V to 12.60V
	-12V	0.5A	±5%	1%	-11.40V to -12.60V
MPB125-4350 ⁶	+3.3V	10A ⁷	±3%	1.5%	3.20V to 3.40V
	+5V	15A ⁷	±4%	1% ⁸	4.85V to 5.25V
	+12V	5A/9Apk	±5%	1%	11.40V to 12.60V
	-12V	0.5A	±5%	1%	-11.40V to -12.60V

NOTES:

- ¹ Maximum peak-to-peak noise expressed as a percentage of output voltage, 20 MHz bandwidth.
 - ² For MPB125-2003DG, a minimum airflow of 10 CFM is required to provide the maximum current of 30A on V1. V1 current can be as high as 25A with a minimum airflow of 5 CFM.
 - ³ Maximum forced-air output power is 125 watts with 5 CFM airflow.
 - ⁴ Maximum convection output power is 70 watts.
 - ⁵ V2 is isolated from V1 and can be used as a negative or positive output.
 - ⁶ V output's peak load maximum duration is 30 seconds. Average current must not exceed 5A.
 - ⁷ Maximum power of 80 watts from V1 + V2 with 5 CFM forced-air cooling. See Application Note #M3 for details.
 - ⁸ For loads less than 10 watts on V1 + V2 + V3, ripple and noise on the +5V output is Max. 2% peak-to-peak.
- Model numbers highlighted in yellow have reached End of Life (EOL) status.
(Last Time Buy (LTB) orders accepted until 30th Sep, 2021; Last Time Ship (LTS) until 31st Dec, 2021)



ORDERING INFORMATION

OPTIONS	SUFFIXES TO ADD TO PART NUMBER
RoHS lead solder exempt ¹	No RoHS suffix character required.
RoHS compliant for all 6 substances	Add "G" as the last character of the part number.
Current Share (Option D)	Provided on dual-output models. Up to 4 units can be connected in parallel. There are some limits for parallel operation. See MPB125 Applications Note. N+1 redundancy is provided. V2 needs an external isolation diode for N+1 operation. An external diode is required on MPB125-2003 and MPB125-2005 models for redundancy on both V1 and V2, or when ordering, you can specify MPB125-2003D or -2005D which have an internal isolation diode.
Remote On/Off Standby Output (Option R)	Remote On/Off is a TTL-compatible signal. A logic "high" or open circuit turns the unit on. Reverse inhibit logic can be achieved by changing the position of the J6 connector. A logic "low" inhibits all outputs except the 5V standby. At remote off, the Power Good signal will warn the host equipment 2 milliseconds before the main output goes out of regulation. The rating of the standby output is +5V @ 0.2 Amps. Total regulation is ±5 %. Maximum noise and ripple is 50 mV peak-to-peak @ a 20 MHz bandwidth. NOTE: The addition of Option "R" increases the supply width from 3.0 to 3.8 inches. Consult factory for availability

¹ The solder exemption refers to all the restricted materials except lead in solder.

INPUT SPECIFICATIONS

PARAMETER	CONDITIONS/DESCRIPTION	MIN	NOM	MAX	UNITS
Input Voltage- AC	Continuous input range	90		264	VAC
Input Frequency	AC Input	47		63	Hz
Brownout Protection	Lowest AC input voltage that regulation is maintained with full rated loads	90			VAC
Hold-up Time	Over full AC input voltage range at full rated load	17			ms
Input Current	90 VAC at full rated load			1.8	A _{RMS}
Input Protection	Non-user serviceable internally located AC input line fuse, 250 VAC, 3.15A.				
Inrush Surge Current	Internally limited by thermistor, one cycle, 25° C	110 VAC:		23	A _{PK}
		220 VAC:		46	
Power Factor Circuitry	Active PFC meets requirements of EN61000-3-2				
Operating Frequency	Switching frequency of main transformer.		45		kHz

OUTPUT SPECIFICATIONS

PARAMETER	CONDITIONS/DESCRIPTION	MIN	NOM	MAX	UNITS
Efficiency	Full Load, 230VAC. Varies with distribution of loads among outputs. (Minimum efficiency reflects that of MPB125-2003D and -2005D models.)	73	80	85	%
Minimum Loads	V1 + V2 + V3 for MPB125-4XXX and -3000. V1 for MPB125-2XXX for full regulation on V2. All models operate at no load without any damage and meet all specs on V1 above 0 amps.	5 5			Watts
Ripple and Noise	Full load, 20 MHz bandwidth	See Model Selection Chart			
Output Power (Note 1)	At 5 CFM forced-air cooling. See Application Note #M3 for details. Convection: Consult Factory			125	Watts
Overshoot /Undershoot	Output voltage overshoot/undershoot at turn-on			10	%



Asia-Pacific
+86 755 298 85888

Europe, Middle East
+353 61 49 8941

North America
+1 866 513 2839

© 2024 Bel Fuse Inc.

BCD.00597_B

Regulation	Varies by output. Total regulation includes: line changes from 85-132 VAC or 170-264 VAC, changes in load starting at 20% load and changing to 100% load	See Model Selection Chart		
Transient Response	Maximum deviation due to a 25% load change with unit at 75% load. All models except MPB125-2005G and -2005D Model MPB125-2005G and -2005D	3 5		%
Turn-on Delay	Time required for initial output voltage stabilization	0.2	1.5	Sec
Turn-on Rise Time	Time required for output voltage to rise from 10% to 90% except for MPB125-2005G and -2005D MPB125-2005G and MPB125-2005D	0.2 1	20 100	ms

INTERFACE SIGNALS AND INTERNAL PROTECTION

PARAMETER	CONDITIONS/DESCRIPTION	MIN	NOM	MAX	UNITS
Overvoltage Protection	V1 of dual and triple output models; V1 & V2 outputs of 4-output models. MPB125-2003 and -2003D	3.67		4.80	VDC
	MPB125-4250 (V1)	3.20		4.00	
	MPB125-4350 (V1)	3.76		4.80	
	5V Output of MPB125-2005 and -2005D, MPB125-3000, or MPB125-4X50	5.74		7.00	
	MPB125-2012	13.5		16.5	
	MPB125-2015	17.0		19.0	
Overload Protection	Fully protected against output short circuit or overload. Automatic recovery upon removal of overload condition. MPB125-2003, -2003D -2005, and -2005D latch OFF if overload occurs on V1 which requires an AC reset.				
	Remote Sense (Note 2) Dual Output Models	Total (+sense and -sense) voltage compensation for cable losses on dual output models.		500	mV
Remote Sense (Note 2) Triple & Quad Output Models	On models MPB125-4350 remote sense is provided on the 2.5 and 3.3V outputs, respectively. MPB125-3000 does not have positive remote sense. Total voltage compensation for cable losses on +Sense. Total voltage compensation for cable losses on -Sense.			200 100	mV
Power Good Signal	AC/DC indicator - This signal indicates the status of the AC input or DC outputs. When there is sufficient AC voltage and the outputs are operating normally, an open collector signal is provided. Turn-On delay time from application of AC:	50		500	ms
	Warning time before outputs go out of regulation:	5			
	Warning time before outputs deviate $\pm 10\%$ from the nominal value:	15			
Power Supply OK Signal	Sync Current			20	mA
	Pull-up Voltage			30	V
	Provided on dual-output models. Open collector signal intended to drive an LED. Closed collector occurs when the Power Good Signal is in its open collector state.				
Thermal Shutdown	Protected against overtemperature conditions. Unit recovers when overtemperature condition is removed.				
	Internal isolation diode is provided on V1 for all dual-output models except the MPB125-2003 and MPB125-2005. Specify MPB125-2003D or MPB125-2005D, respectively, if an internal isolation diode is required for these models.				

NOTES:

- 1) For MPB125-2003, a minimum airflow of 10 CFM is required to provide the maximum current of 30A on V1. V1 current can be as high as 25A with a minimum airflow of 5 CFM.
- 2) -Sense must be connected to output common or load common for proper power supply operation.



SAFETY, REGULATORY, AND EMI SPECIFICATIONS

PARAMETER	CONDITIONS/DESCRIPTION	MIN	NOM	MAX	UNITS
Agency Approvals	Approved to latest edition of the following standards: UL/CSA 62368-1, EN IEC 62368-1, IEC 62368-1				
Dielectric Withstand Voltage	Input to Chassis	2121			VDC
	Input to Output (Tested by manufacturer only)	4242			VDC
Electromagnetic Interference	EN55022 Conducted	B			Class
ESD Susceptibility	Per EN61000-4-2, Level 4	8			kV
Flicker	Per EN61000-3-3				
Radiated Susceptibility	Per EN61000-4-3		3		V/m
EFT/Burst	Per EN61000-4-4	1			kV
Input Transient Protection	Per EN61000-4-5, Level 3, 2 kV (Line-to-Ground) minimum, 1 kV (Line-to-Line) minimum.				
RF Immunity	Per EN61000-4-6. 0.15 to 80 MHz (1 kHz sine wave)		3		V/m
Magnetic Fields	Per EN61000-4-8		1		A/m
Voltage Dips	Per EN61000-4-11				
Insulation Resistance	Input to output.		10		MΩ
Leakage Current	Per EN60950 (264 VAC)			1.0	mA

ENVIRONMENTAL SPECIFICATIONS

PARAMETER	CONDITIONS/DESCRIPTION	MIN	NOM	MAX	UNITS
Altitude	Operating			10K	ASL Feet
	Non-Operating			50K	
Operating Temperature	Derate linearly from 50 to 70°C to 50% power at 70°C. At 100% load: MPB125 models will operate at -20°C, but will not meet all specifications.	0		50	°C
Storage Temperature		-40		85	°C
Forced-Air Cooling ¹⁾	Forced-air cooling of 5 CFM is required for full output power except for MPB125-2003 and -2003D. Air velocity is measured with power supply mounted on 0.375" (9.5mm) standoffs. Airflow direction is from the input section to the output section. See Application Note #M3 for details.				
Temperature Coefficient	Included in total regulation of outputs				
Relative Humidity	Non-Condensing	5		95	%RH
Shock	Operating: 11 ±3ms, 3 axes, Half Sine			15	Gpk
	Non-operating: 11 ±3ms, 3 axes, Half Sine			40	
Vibration	Operating: Random vibration, 5-500 Hz, 10 minutes each axis.			2.4	G _{RMS}
	Non-Operating: Random vibration, 5-500 Hz, 10 minutes each axis			6.0	

NOTES:

- ¹ For MPB125-2003 and -2003D, a minimum airflow of 10 CFM is required to provide the maximum current of 30A on V1. V1 current can be as high as 25A with a minimum airflow of 5 CFM.



Asia-Pacific
+86 755 298 85888

Europe, Middle East
+353 61 49 8941

North America
+1 866 513 2839

© 2024 Bel Fuse Inc. BCD.00597_B

MPB125 Multiple-Output Series

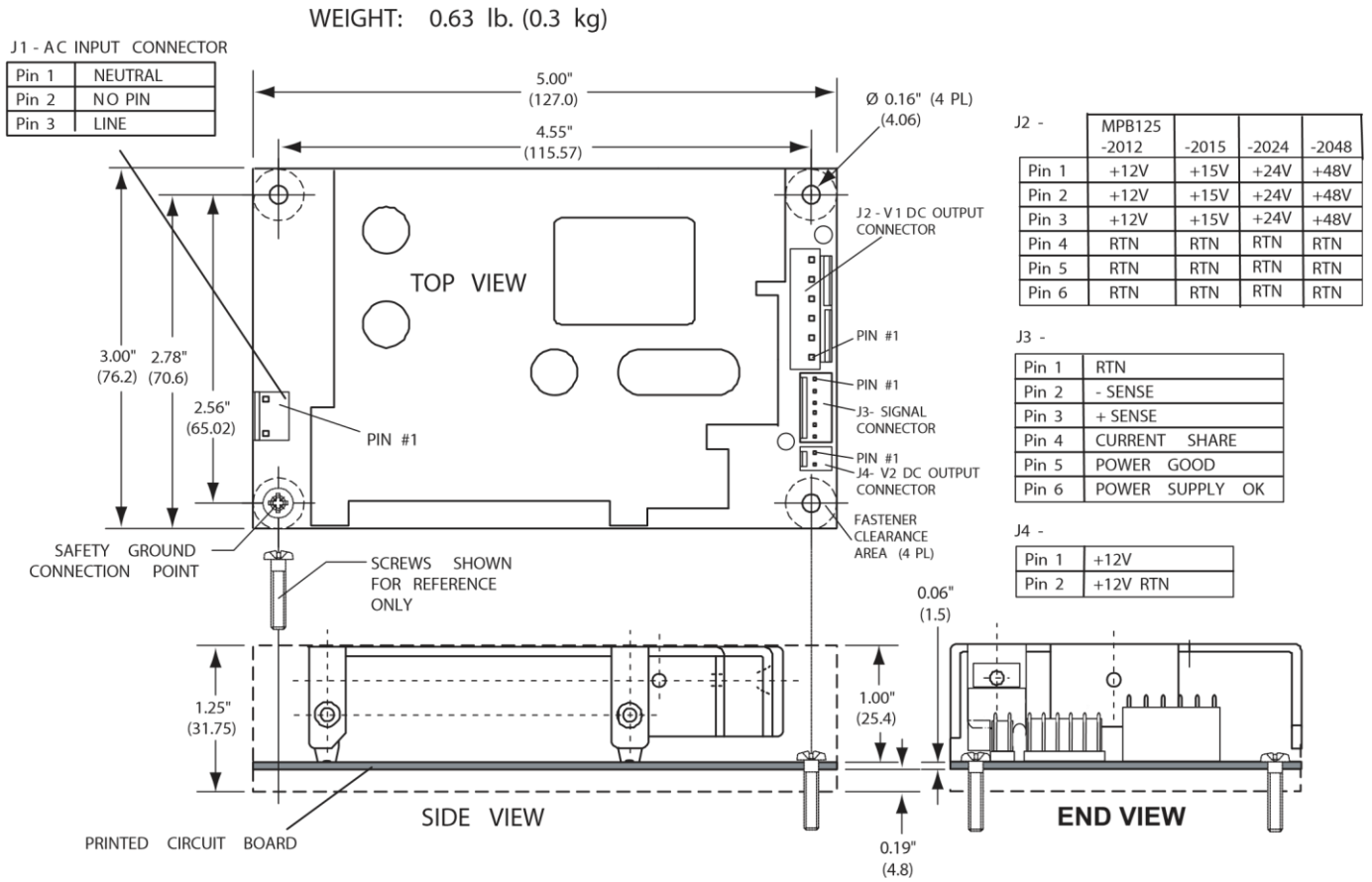

Figure 1 - Mechanical Drawing (-2012, -2015, -2024, & -2048 Models)

Mating Connectors

NOTE: Part numbers are MOLEX; equivalents are acceptable.

MPB125-2012, -2015, -2024, -2048		
J1	Housing	09-50-8031
	Pins	08-52-0113
J2	Housing	09-50-8061
	Pins	08-52-0113
J3	Housing	22-01-3067
	Pins	08-50-0114
J4	Housing	22-01-3027
	Pins	08-50-0114



MPB125 Multiple-Output Series

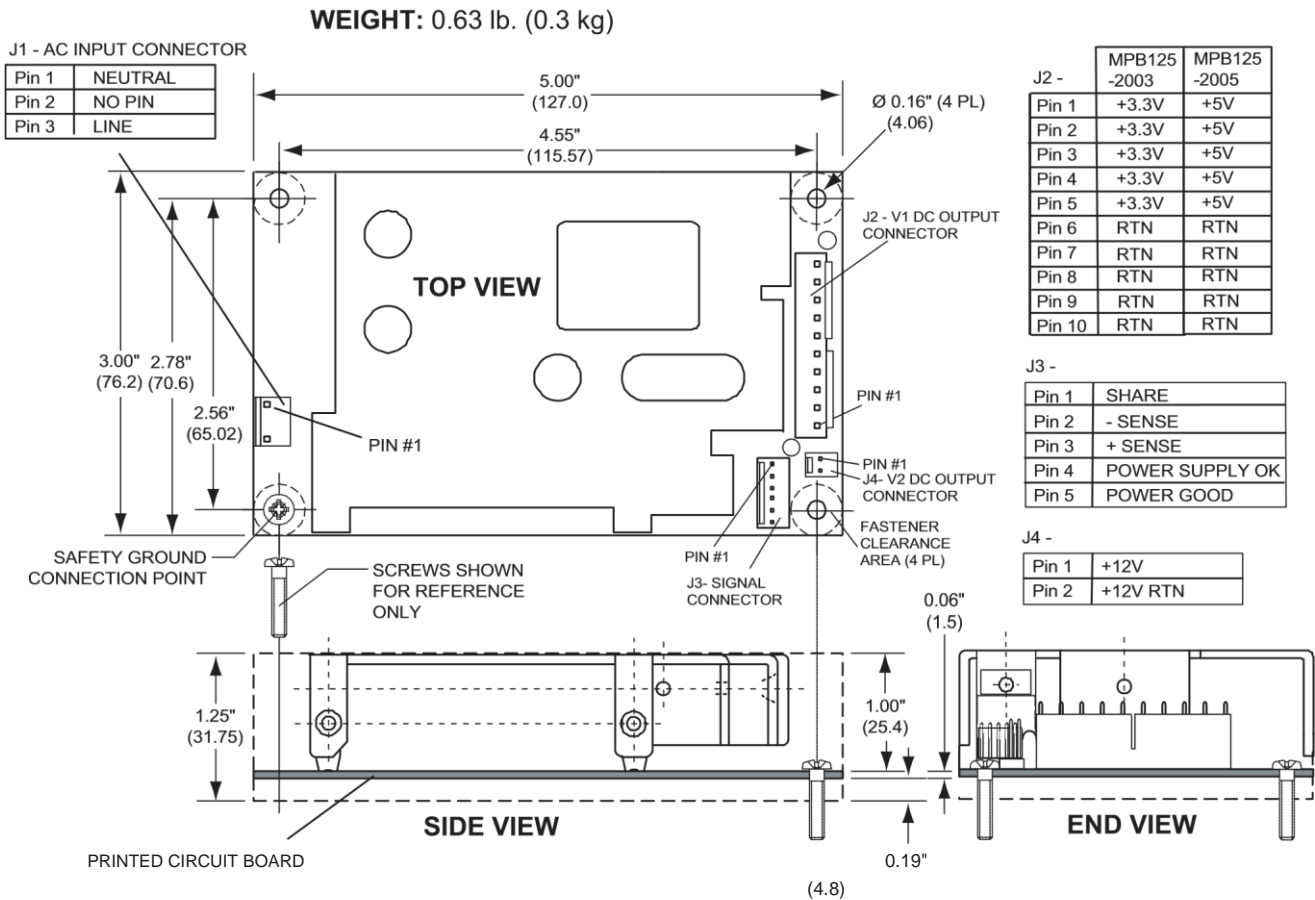

Figure 2 - Mechanical Drawing (-2003, -2003D, -2005, and -2005D Models)

Mating Connectors

NOTE: Part numbers are MOLEX; equivalents are acceptable.

MPB125-2005		
J1	Housing	09-50-8031
	Pins	08-52-0113
J2	Housing	09-50-8103
	Pins	08-52-0113
J3	Housing	22-01-3057
	Pins	08-50-0114
J4	Housing	22-01-3027
	Pins	08-50-0114



Asia-Pacific
+86 755 298 85888

Europe, Middle East
+353 61 49 8941

North America
+1 866 513 2839

© 2024 Bel Fuse Inc. BCD.00597_B

MPB125 Multiple-Output Series

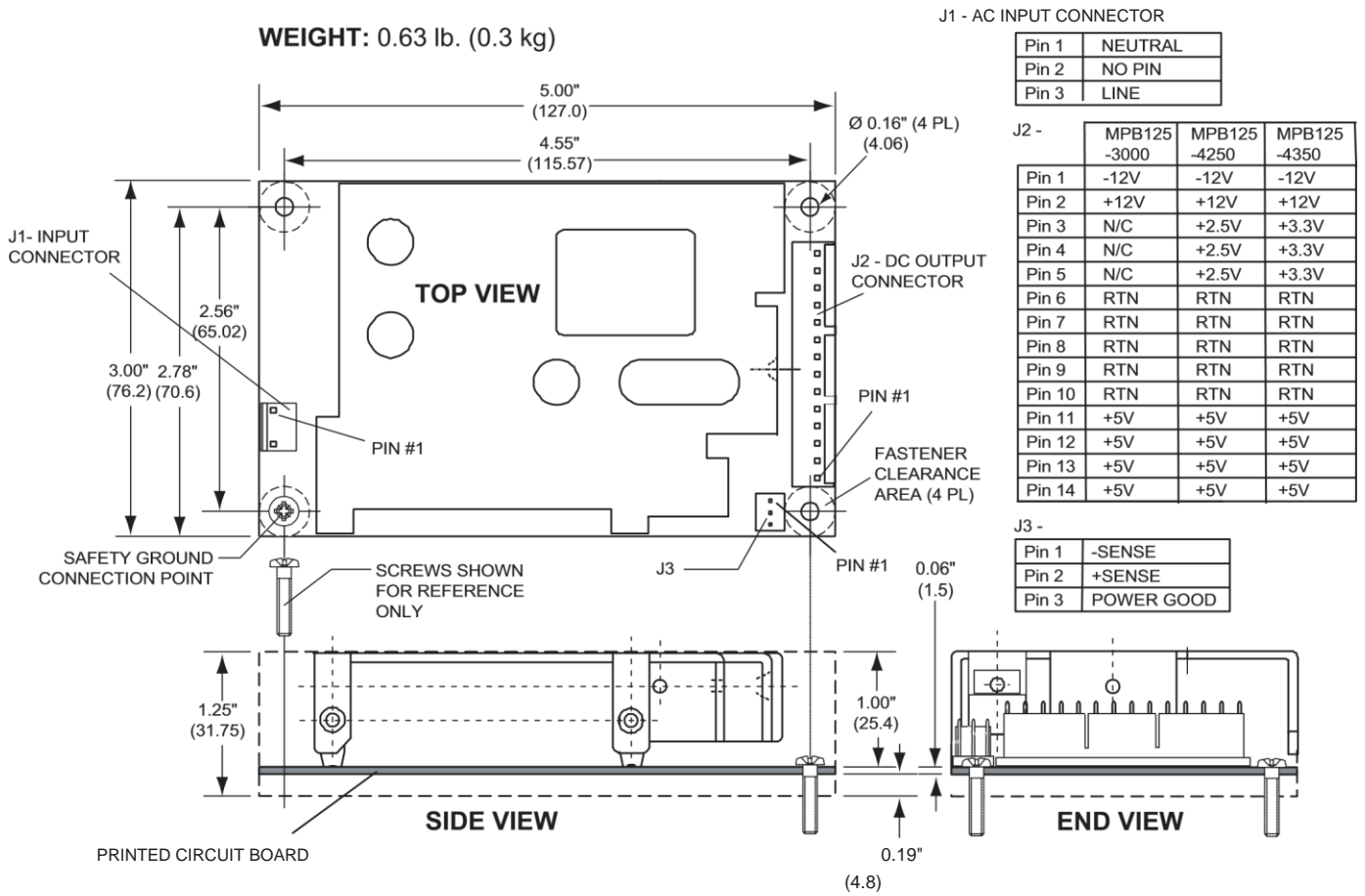

Figure 3 - Mechanical Drawing (-3000, -4250, & -4350 Models)

Mating Connectors

NOTE: Part numbers are MOLEX; equivalents are acceptable.

MPB125-3000, -4250, -4350		
J1	Housing	09-50-8033
	Pins	08-52-0113
J2	Housing	09-50-8143
	Pins	08-52-0113
J3	Housing	22-01-3037
	Pins	08-50-0114



MPB125 Series "R" Option

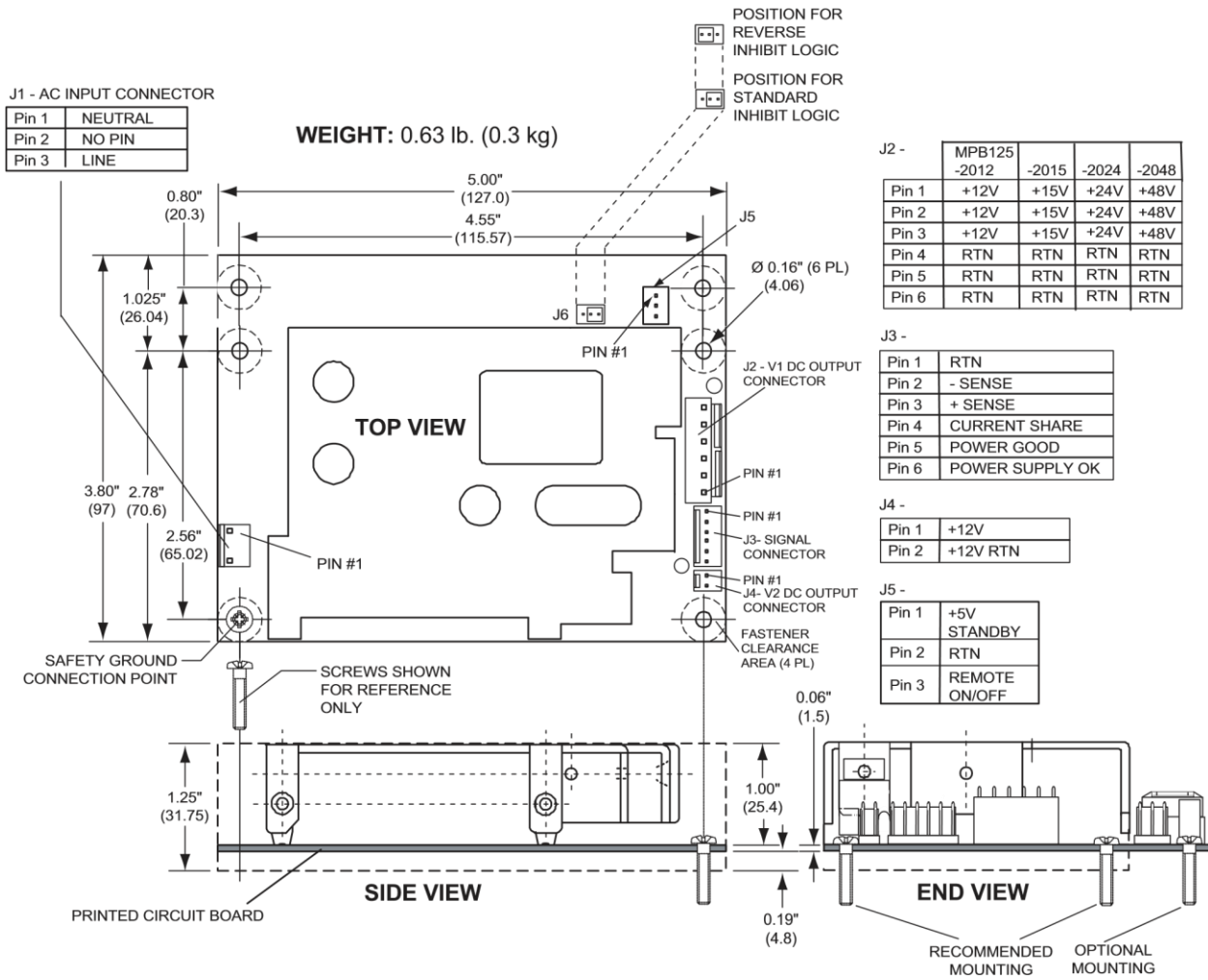

Mating Connectors

NOTE: Part numbers are MOLEX; equivalents are acceptable.

MPB125-2012, -2015, -2024, -2048		
J1	Housing	09-50-8033
	Pins	08-52-0113
J2	Housing	09-50-8063
	Pins	08-52-0113
J3	Housing	22-01-3067
	Pins	08-50-0114
J4	Housing	22-01-3027
	Pins	08-50-0114
J5	Housing	22-01-3037
	Pins	08-50-0114



MPB125 Multiple-Output Series

MPB125 Series "R" Option

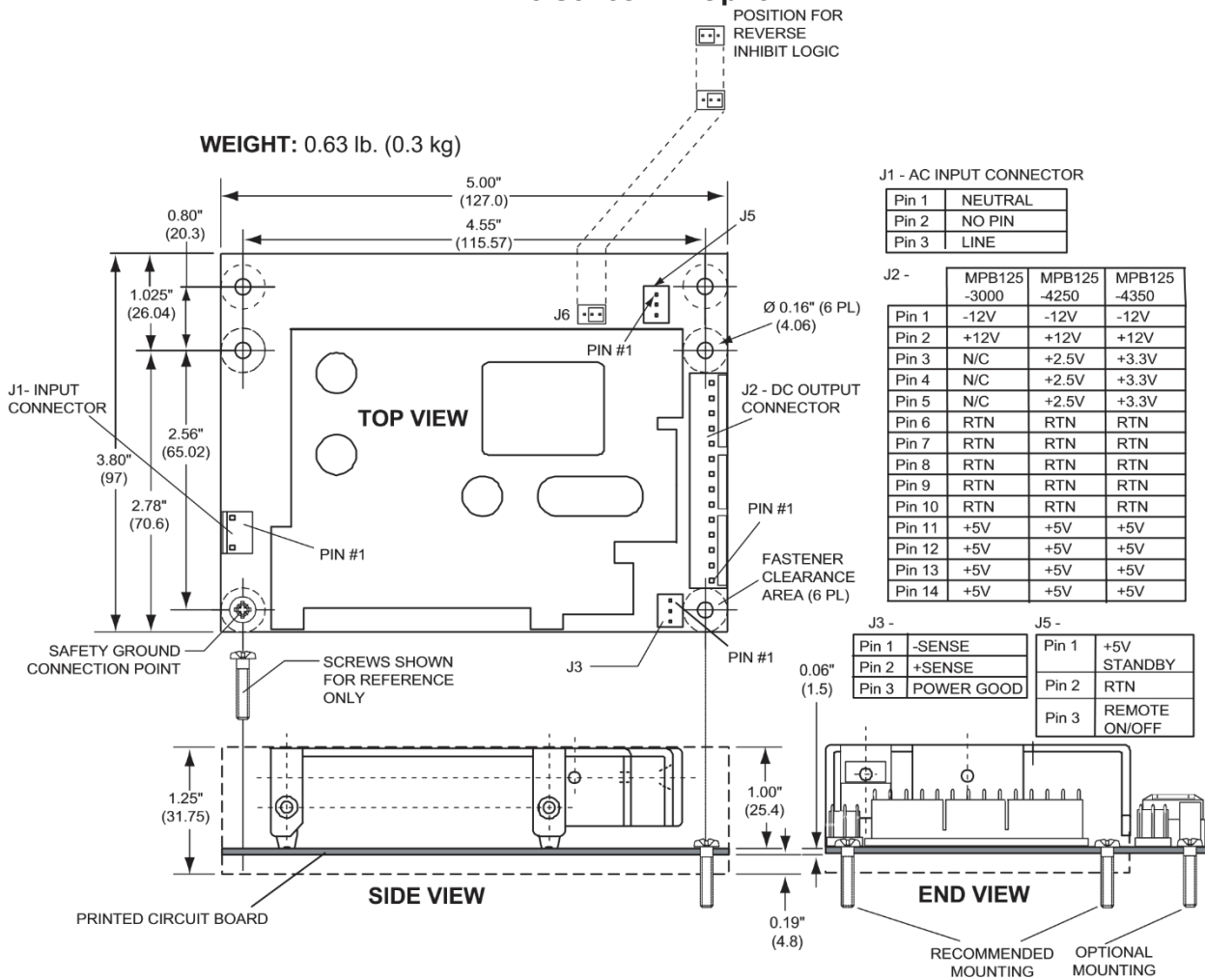

Mechanical Drawing (-3000R, -4250R, & -4350R Models)

Mating Connectors

NOTE: Part numbers are MOLEX; equivalents are acceptable.

MPB125-3000R, -4250R, -4350R		
J1	Housing	09-50-8033
	Pins	08-52-0113
J2	Housing	09-50-8143
	Pins	08-52-0113
J3	Housing	22-01-3037
	Pins	08-50-0114
J5	Housing	22-01-3037
	Pins	08-50-0114

For more information on these products consult: tech.support@psbel.com

NUCLEAR AND MEDICAL APPLICATIONS - Products are not designed or intended for use as critical components in life support systems, equipment used in hazardous environments, or nuclear control systems.

TECHNICAL REVISIONS - The appearance of products, including safety agency certifications pictured on labels, may change depending on the date manufactured. Specifications are subject to change without notice.



tech.support@psbel.com
belfuse.com/power-solutions