

■Features

- High Luminous LEDs
- Low Power Consumption
- UV Resistant Epoxy
- Specified at $I_F = 1 \text{ mA}$
- White Diffused

■Applications

- Background illumination
- Communications equipment
- Low power DC circuits
- General lighting purposes

■Outline Dimension

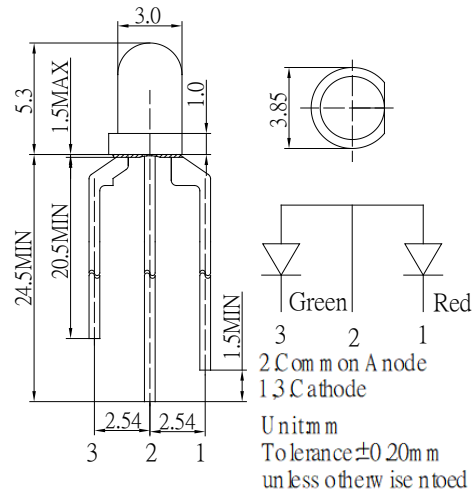

■Absolute Maximum Rating

($T_a=25^\circ\text{C}$)

Item	Symbol	Value		Unit
		Red	Green	
DC Forward Current	I_F	30	30	mA
Pulse Forward Current#	I_{FP}	100	100	mA
Reverse Voltage	V_R	5	5	V
Power Dissipation	P_D	72	96	mW
Operating Temperature	T_{opr}	-30~ +85		$^\circ\text{C}$
Storage Temperature	T_{stg}	-40 ~ +100		$^\circ\text{C}$
Lead Soldering Temperature	T_{sol}	260 $^\circ\text{C}$ /5sec		-

■Directivity

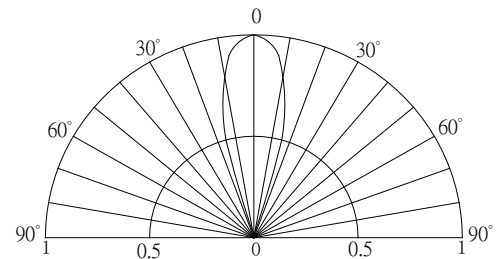

#Pulse width Max.10ms Duty ratio max 1/10

■Electrical -Optical Characteristics

($T_a=25^\circ\text{C}$)

Item	Symbol	Condition	Min.	Typ.	Max.	Unit
DC Forward Voltage*1	V_F (RED)	$I_F=1\text{mA}$	-	1.9	2.4	V
	V_F (Green)	$I_F=1\text{mA}$	-	2.7	3.2	V
DC Reverse Current	I_R	$V_R=5\text{V}$	-	-	10	μA
Domi. Wavelength*2	λ_D (RED)	$I_F=1\text{mA}$	620	625	630	nm
	λ_D (Green)	$I_F=1\text{mA}$	520	525	530	nm
Luminous Intensity*3	I_v (RED)	$I_F=1\text{mA}$	100	150	-	mcd
	I_v (Green)	$I_F=1\text{mA}$	200	330	-	mcd
50% Power Angle	$2\theta_{1/2}$	$I_F=1\text{mA}$	-	30	-	deg

*1 Tolerance of measurements of forward voltage is $\pm 0.1\text{V}$

*2 Tolerance of measurements of dominant wavelength is $\pm 1\text{nm}$

*3 Tolerance of measurements of luminous intensity is $\pm 15\%$