

REVISIONS					
P	LTR	DESCRIPTION	DATE	DWN	APVD
	A	INITIAL RELEASE	10APR23	H.P	Z.Z
	B	REVISION (PCN-24-224062)	16DEC24	S.W	Z.Z

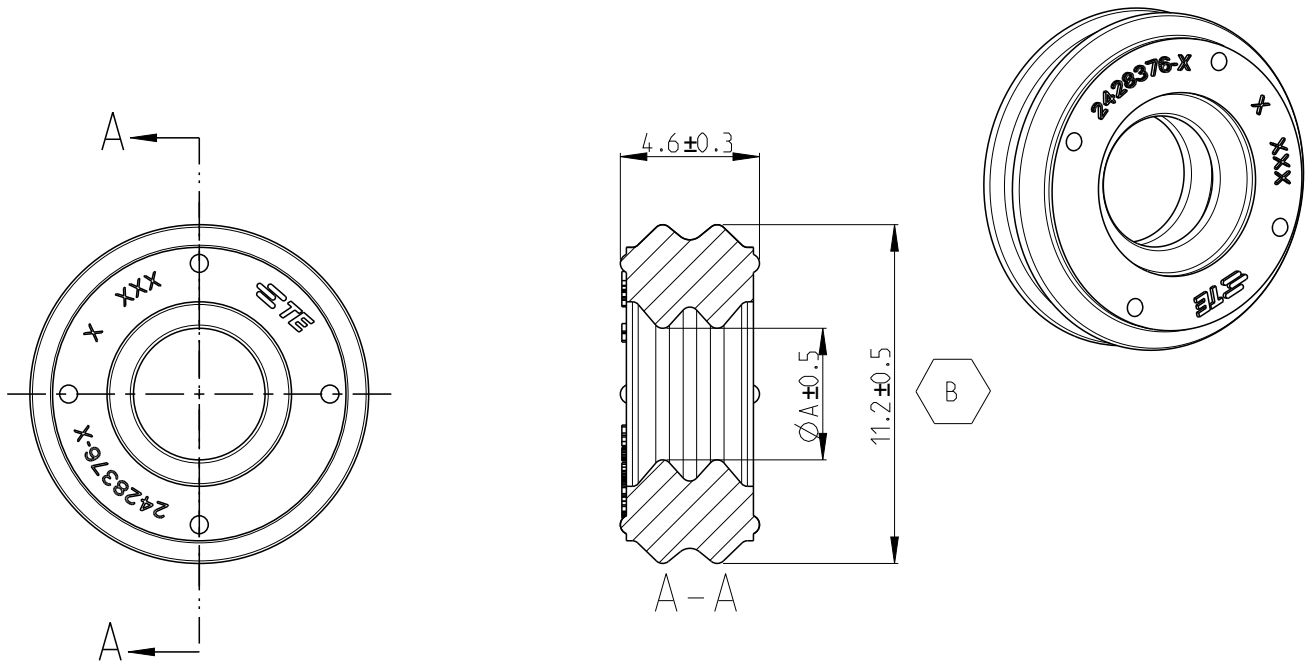

⚠ MATERIAL:
 INHERENTLY LUBRICATED SILICONE;
 COLOR: SEE CHART;

- PART DIMENSIONS SHOWN ARE IN FREE STATE CONDITION;
- FEATURE DENOTED BY REFERENCE DIMENSIONS MUST BE INSPECTED FOR PRESENCE;
- PARR MUST BE FREE OF EXCESSIVE FLASH, MIS-MATCH, STAINS, SCORES, SINK MARKS, OR OTHER VISUAL IMPERFECTIONS THAT MAY AFFECT PRODUCTION FIT OR FUNCTION.

© 2022 TE Connectivity. All Rights Reserved.

5.10	BROWN	FOR 5SQM	2428376-2
4.35	YELLOW	FOR 3SQM	2428376-1
DIM.A	COLOR	DESCRIPTION	PART NO

DIMENSIONS: mm TOLERANCES UNLESS OTHERWISE SPECIFIED: 0 PLC ± 1 PLC ±0.1 2 PLC ±0.01 3 PLC ±0.001 4 PLC ±0.0001 ANGLES ±	DWN H.PENG 08NOV2022	MATERIAL	FINISH	
	CHK J.LI 08NOV2022			
	APVD Z.ZHOU 08NOV2022			
	PRODUCT SPEC 108-160170	NAME	SINGLE WIRE SEAL HD400	
APPLICATION SPEC 114-160093	SIZE	CAGE CODE	DRAWING NO	RESTRICTED TO
WEIGHT -	A 4	00779	C=2428376	-
CUSTOMER DRAWING	SCALE	SHEET		REV
	4:1	1 OF 1		B