

# NCV891234, NCV891334

## 2 MHz Low- $I_Q$ Dual-Mode Step-Down Regulator for Automotive

The NCV891x34 is a Dual Mode regulator intended for Automotive, battery-connected applications that must operate with up to a 45 V input supply. Hybrid Low Power Mode allows the NCV891x34 to operate either as a PWM Buck Converter or as a Low Drop-Out Linear Regulator, and the NCV891x34 is suitable for systems with Low Noise and Low Quiescent Current requirements often encountered in automotive driver information systems. A reset (with fixed delay) and a fault pin (flagging low input voltage and high temperature warnings) simplify interfacing with a microcontroller.

Two pins are provided to synchronize switching to a clock, or to another NCV891x34. The NCV891x34 also provides several protection features expected in automotive power supply systems such as current limit, short circuit protection, and thermal shutdown. In addition, the high switching frequency produces low output voltage ripple even when using small inductor values and an all-ceramic output filter capacitor – forming a space-efficient switching regulator solution.

### Features

- 40  $\mu$ A  $I_Q$  in Light Load Condition
- 2.0 A Maximum Output Current in PWM Mode in NCV891234
- 3.0 A Maximum Output Current in PWM Mode in NCV891334
- Internal N-channel Power Switch
- $V_{IN}$  Operating Range 3.7 V to 36 V, Withstands Load Dump to 45 V
- Logic Level Enable Pin can be Tied to Battery
- Fixed Output Voltage of 5.0 V or 3.3 V with  $\pm 2\%$  Accuracy
- 2 MHz Free-running Switching Frequency
- Input and Output Synchronization Pins
- NCV Prefix for Automotive Requiring Site and Control Changes
- Wettable Flanks DFN (pin edge plating)
- These Devices are Pb-Free and are RoHS Compliant

### Typical Applications

- Safety-Vision Systems
- Audio, Infotainment
- Instrumentation
- Telematics

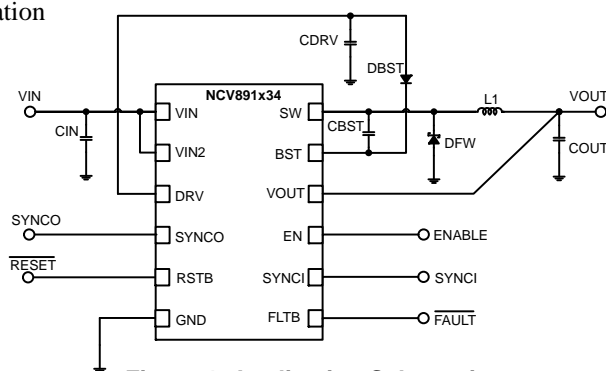
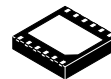

Figure 1. Application Schematic



ON Semiconductor®

[www.onsemi.com](http://www.onsemi.com)



1

DFN12  
MW SUFFIX  
CASE 506CE

### MARKING DIAGRAM

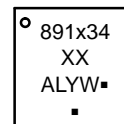

891x34XX = Specific Device Code

x = 2, 3

XX = 33, 50

A = Assembly Location

L = Wafer Lot

Y = Year

W = Work Week

▪ = Pb-Free Device

(Note: Microdot may be in either location)

### PIN CONNECTIONS

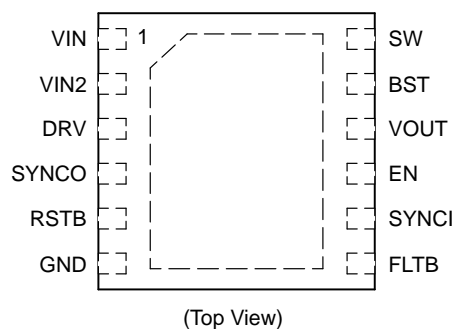

### ORDERING INFORMATION

See detailed ordering and shipping information on page 10 of this data sheet.

# NCV891234, NCV891334

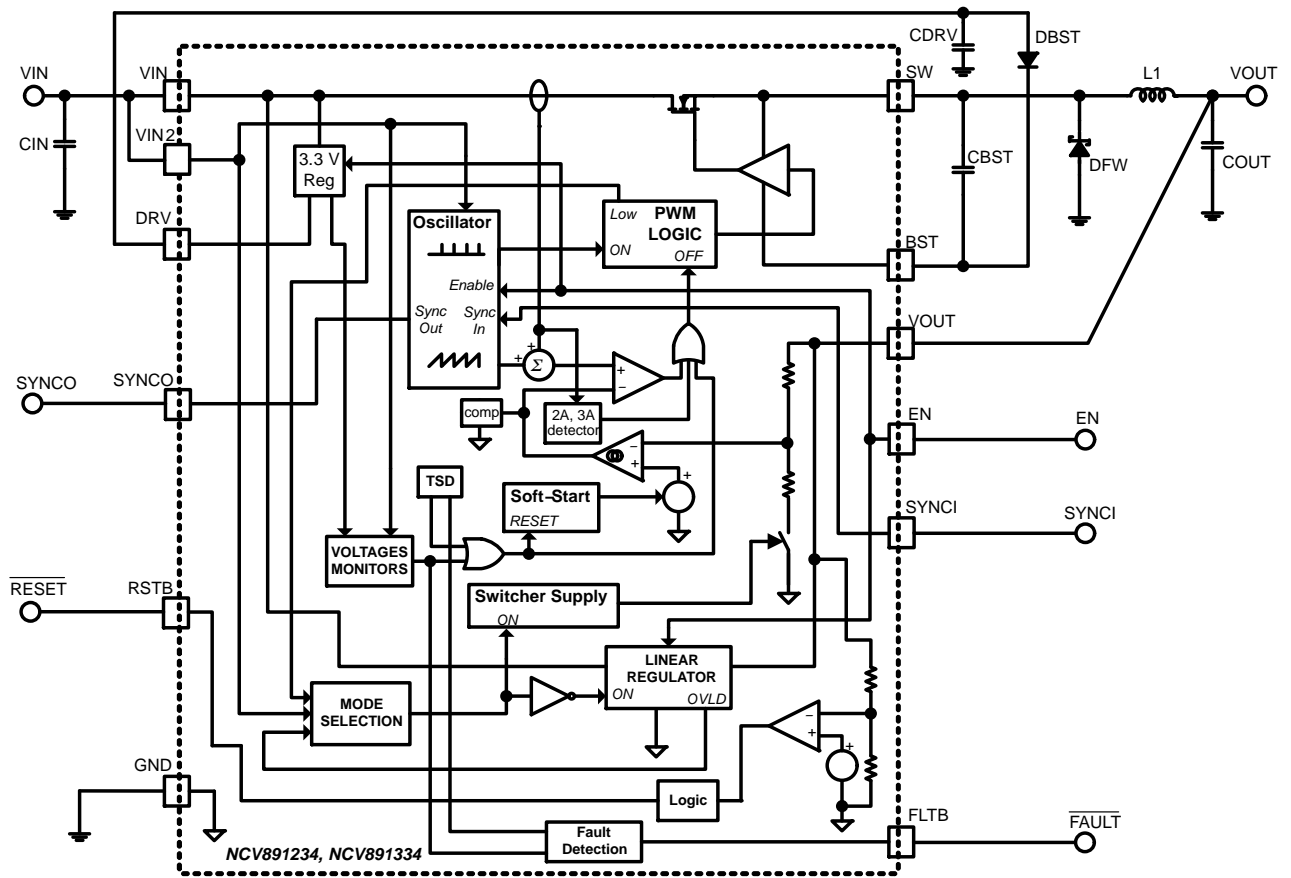

Figure 2. Simplified Block Diagrams

# NCV891234, NCV891334

**Table 1. PIN FUNCTION DESCRIPTION**

Pin No.	Pin Name	Description
1	VIN	Input voltage from battery. Place an input filter capacitor in close proximity to this pin.
2	VIN2	Input voltage pin – must be connected to VIN (pin 1)
3	DRV	Output voltage to provide a regulated voltage to the Power Switch gate driver.
4	SYNCO	Out-of-phase synchronization output. Turn-on of the Power Switch causes the SYNCO signal to fall (and rise half a switching period later).
5	RSTB	Reset function. Open drain output, pulling down to ground when the output voltage is out of regulation.
6	GND	Battery return, and output voltage ground reference.
7	FLT B	Fault flag indicating various fault conditions for the part
8	SYNCl	Synchronization input. Connecting an external clock to this pin synchronizes switching to the rising edge of the SYNCl signal.
9	EN	This TTL compatible Enable input allows the direct connection of Battery as the enable signal. Grounding this input stops switching and reduces quiescent current draw to a minimum.
10	VOUT	Output voltage feedback and LDO output. Feedback of output voltage used for regulation, as well as LDO output in LDO mode.
11	BST	Bootstrap input provides drive voltage higher than VIN to the N-channel Power Switch for minimum switch R <sub>ds(on)</sub> and highest efficiency.
12	SW	Switching node of the Regulator. Connect the output inductor and cathode of the freewheeling diode to this pin.
EPAD		Connect to Pin 6 (electrical ground) and to a low thermal resistance path to the ambient temperature environment.

**Table 2. ABSOLUTE MAXIMUM RATINGS**

Rating	Symbol	Value	Unit
Min/Max Voltage VIN		-0.3 to 45	V
Max Voltage VIN to SW		45	V
Min/Max Voltage SW		-0.7 to 40	V
Min Voltage SW – 20 ns		-3.0	V
Min/Max Voltage EN		-0.3 to 40	V
Min/Max Voltage BST		-0.3 to 43	V
Min/Max Voltage BST to SW		-0.3 to 3.6	V
Min/Max Voltage SYNCl, RSTB and FLT B		-0.3 to 6	V
Min/Max Voltage VOUT		-0.3 to 18	V
Min/Max Voltage DRV, SYNCO		-0.3 to 3.6	V
Thermal Resistance, DFN12-4x4 Junction-to-Ambient (Note 1)	R <sub>θJA</sub>	35	°C/W
Storage Temperature Range		-55 to +150	°C
Operating Junction Temperature Range	T <sub>J</sub>	-40 to +150	°C
ESD Withstand Voltage (Note 2) – Human Body Model	VESD	2.0	kV
Moisture Sensitivity	MSL	Level 1	
Peak Reflow Soldering Temperature (Note 3)		260	°C

Stresses exceeding those listed in the Maximum Ratings table may damage the device. If any of these limits are exceeded, device functionality should not be assumed, damage may occur and reliability may be affected.

- Value based on 4 layers of 645 mm<sup>2</sup> (or 1 in<sup>2</sup>) of 1 oz copper thickness on FR4 PCB substrate.
- This device series incorporates ESD protection and is tested by the following methods:  
 ESD Human Body Model tested per AEC-Q100-002 (EIA/JESD22-A114)  
 Latchup Current Maximum Rating: ≤ 150 mA per JEDEC standard: JESD78
- For information, please refer to our Soldering and Mounting Techniques Reference Manual, SOLDERRM/D

# NCV891234, NCV891334

**Table 3. ELECTRICAL CHARACTERISTICS**

$V_{IN} = 4.5$  to  $28$  V,  $V_{EN} = 5$  V,  $V_{BST} = V_{SW} + 3$  V,  $C_{DRV} = 0.1$   $\mu$ F, for typical values  $T_J = 25^\circ\text{C}$ , min/max values are valid for  $T_J = -40^\circ\text{C}$  to  $150^\circ\text{C}$  unless noted otherwise, and are guaranteed by test, design or statistical correlation (Notes 4, 5)

Parameter	Test Conditions	Symbol	Min	Typ	Max	Unit
<b>QUIESCENT CURRENT</b>						
Quiescent Current, enabled	$V_{IN} = 13.2$ V, $I_{OUT} = 100$ $\mu$ A, $25^\circ\text{C}$	$I_q$		40	49	$\mu$ A
Quiescent Current, shutdown	$V_{IN} = 13.2$ V, $V_{EN} = 0$ V, $25^\circ\text{C}$	$I_{qSD}$		9	12	$\mu$ A
<b>UNDERVOLTAGE LOCKOUT – VIN (UVLO)</b>						
UVLO Start Threshold	$V_{IN}$ rising	$V_{UVLSTT}$	4.1		4.5	V
UVLO Stop Threshold	$V_{IN}$ falling	$V_{UVLSTP}$	3.1		3.7	V
UVLO Hysteresis		$V_{UVLOHY}$	0.4		1.4	V
<b>SOFT-START (SS)</b>						
Soft-Start Completion Time		$t_{SS}$	0.8	1.4	2.0	ms
<b>OUTPUT VOLTAGE</b>						
Output Voltage during regulation	$100$ $\mu$ A $< I_{OUT} < 2.5$ A 5.0 V option 3.3 V option	$V_{OUTreg}$	4.9 3.234	5.0 3.3	5.1 3.366	V
<b>OSCILLATOR</b>						
Frequency	$4.5 < V_{IN} < 18$ V $20$ V $< V_{IN} < 28$ V	$F_{SW}$ $F_{SW(HV)}$	1.8 0.9	2.0 1.0	2.2 1.1	MHz
<b>VIN FREQUENCY FOLDBACK MONITOR</b>						
Frequency Foldback Threshold $V_{IN}$ rising $V_{IN}$ falling		$V_{FLDUP}$ $V_{FLDDN}$	18.4 18		20 19.8	V
Frequency Foldback Hysteresis		$V_{FLDHY}$	0.2	0.3	0.4	V
<b>MODE TRANSITION</b>						
Normal to Low- $I_q$ mode Current Threshold		$I_{NtoL}$	3		40	mA
Mode Transition Duration Switcher to Linear Linear to Switcher		$t_{SWtoLIN}$ $t_{LINtoSW}$		300 1		$\mu$ s 2
Minimum time in Normal Mode before starting to monitor output current		$t_{SWblank}$		500		$\mu$ s
Linear to switcher transition at high $V_{in}$ at low $V_{in}$	$V_{OUT} = 3.3$ V	$V_{LINtoSW(HV)}$ $V_{LINtoSW(LV)}$	19 3.6		28 4.5	V
<b>PEAK CURRENT LIMIT</b>						
Current Limit Threshold NCV891334		$I_{LIM}$	3.9	4.4	4.9	A
Current Limit Threshold NCV891234		$I_{LIM}$	2.9	3.25	3.6	A
<b>POWER SWITCH</b>						
ON Resistance	$V_{BST} = V_{SW} + 3.0$ V	$R_{DSON}$		180	360	m $\Omega$
Leakage current VIN to SW	$V_{SW} = 0$ , $-40^\circ\text{C} \leq T_J \leq 85^\circ\text{C}$	$I_{LKSW}$			10	$\mu$ A
Minimum ON Time	Measured at SW pin	$t_{ONMIN}$	45		70	ns
Minimum OFF Time	Measured at SW pin At $F_{SW} = 2$ MHz (normal) At $F_{SW} = 500$ kHz (max duty ratio)	$t_{OFFMIN}$		30 50		ns 70

- Refer to ABSOLUTE MAXIMUM RATINGS and APPLICATION INFORMATION for Safe Operating Area.
- Performance guaranteed over the indicated operating temperature range by design and/or characterization tested at  $T_J = T_A = 25^\circ\text{C}$ . Low duty cycle pulse techniques are used during testing to maintain the junction temperature as close to ambient as possible.

# NCV891234, NCV891334

**Table 3. ELECTRICAL CHARACTERISTICS**

$V_{IN} = 4.5$  to  $28$  V,  $V_{EN} = 5$  V,  $V_{BST} = V_{SW} + 3$  V,  $C_{DRV} = 0.1$   $\mu$ F, for typical values  $T_J = 25^\circ\text{C}$ , min/max values are valid for  $T_J = -40^\circ\text{C}$  to  $150^\circ\text{C}$  unless noted otherwise, and are guaranteed by test, design or statistical correlation (Notes 4, 5)

Parameter	Test Conditions	Symbol	Min	Typ	Max	Unit
-----------	-----------------	--------	-----	-----	-----	------

**SLOPE COMPENSATION**

Ramp Slope (With respect to switch current)	$4.5 < V_{IN} < 18$ V $20 < V_{IN} < 28$ V	$S_{ramp}$ $S_{ramp(HV)}$	1.45 0.65	2.0 1.0	2.8 1.3	A/ $\mu$ s
--	---	------------------------------	--------------	------------	------------	------------

**LOW POWER LINEAR REGULATOR**

Line Regulation	$I_{OUT} = 5$ mA, $6 < V_{IN} < 18$ V	$V_{REG(line)}$		5	25	mV
Load Regulation	$V_{IN} = 13.2$ V, $0.1$ mA $< I_{OUT} < 50$ mA	$V_{REG(load)}$		5	35	mV
Power Supply Rejection	$V_{OUT(ripple)} = 0.5$ Vp-p, $F = 100$ Hz	PSRR		65		dB
Current Limit		$I_{LIN(lim)}$	50		80	mA
Output clamp current	$V_{OUT} = V_{OUTreg(typ)} + 10\%$	$I_{CL(OUT)}$	0.5	1.0	1.5	mA

**SHORT CIRCUIT DETECTOR**

Switching frequency in short-circuit condition Analog Foldback Analog foldback – high $V_{IN}$ Hiccup Mode	$V_{OUT} = 0$ V, $4.5 < V_{IN} < 18$ V $V_{OUT} = 0$ V, $20 < V_{IN} < 28$ V	$F_{SWAF}$ $F_{SWAFHV}$ $F_{SWHIC}$	450 225 24	550 275 32	650 325 40	kHz
---	---	---	------------------	------------------	------------------	-----

**RESET**

Leakage current into RSTB pin					1	$\mu$ A
Output voltage threshold at which the RSTB signal goes low	$V_{OUT}$ decreasing 5.0 V option 3.3 V option	$V_{RESET}$	4.50 2.97	4.625 3.05	4.75 3.14	V
Hysteresis on RSTB threshold	$V_{OUT}$ increasing 5.0 V option 3.3 V option	$V_{RESHys}$	25 17	60 40	100 66	mV
Noise-filtering delay	From $V_{OUT} < V_{RESET}$ to RSTB pin going low	$t_{filter}$	10		25	$\mu$ s
Restart Delay time	From $V_{OUT} > V_{RESET} + V_{RESHys}$ to high RSTB	$t_{delay}$	14	16	18	ms
Low RSTB voltage	$R_{RSTBpullup} = V_{OUTreg}/1$ mA, $V_{OUT} > 1$ V	$V_{RSTBlow}$			0.4	V

**GATE VOLTAGE SUPPLY (DRV pin)**

Output Voltage		$V_{DRV}$	3.1	3.3	3.5	V
DRV UVLO START Threshold		$V_{DRVSTT}$	2.7	2.9	3.05	V
DRV UVLO STOP Threshold		$V_{DRVSTP}$	2.5	2.8	3.0	V
DRV UVLO Hysteresis		$V_{DRVHYS}$	50		200	mV
DRV Current Limit	$V_{DRV} = 0$ V	$I_{DRVlim}$	21		50	mA

**VIN OVERVOLTAGE SHUTDOWN MONITOR**

Overvoltage Stop Threshold	$V_{IN}$ increasing	$V_{OVSTP}$	36.5	37.7	39.0	V
Overvoltage Start Threshold	$V_{IN}$ decreasing	$V_{OVSTT}$	36.0	37.3	38.8	V
Overvoltage Hysteresis		$V_{OVHY}$	0.25	0.40	0.50	V

**ENABLE (EN)**

Logic low threshold voltage		$V_{ENlow}$	0.8			V
Logic high threshold voltage		$V_{ENhigh}$			2	V
EN pin input current		$I_{ENbias}$	0.2		1	$\mu$ A

- Refer to ABSOLUTE MAXIMUM RATINGS and APPLICATION INFORMATION for Safe Operating Area.
- Performance guaranteed over the indicated operating temperature range by design and/or characterization tested at  $T_J = T_A = 25^\circ\text{C}$ . Low duty cycle pulse techniques are used during testing to maintain the junction temperature as close to ambient as possible.

# NCV891234, NCV891334

**Table 3. ELECTRICAL CHARACTERISTICS**

$V_{IN} = 4.5$  to  $28$  V,  $V_{EN} = 5$  V,  $V_{BST} = V_{SW} + 3$  V,  $C_{DRV} = 0.1$   $\mu$ F, for typical values  $T_J = 25^\circ\text{C}$ , min/max values are valid for  $T_J = -40^\circ\text{C}$  to  $150^\circ\text{C}$  unless noted otherwise, and are guaranteed by test, design or statistical correlation (Notes 4, 5)

Parameter	Test Conditions	Symbol	Min	Typ	Max	Unit
<b>SYNCHRONIZATION</b>						
SYNCl pin input resistance to GND	$V_{SYNCl} = 5$ V	RHsynci	50		200	k $\Omega$
High threshold voltage		VHsynci			2	V
Low threshold voltage		VLsynci	0.8			V
Minimum high pulse width	$V_{SYNCl} > V_{Hsynci(max)}$	tHsynci	40			ns
Minimum low pulse width	$V_{SYNCl} < V_{Lsynci(min)}$	tLsynci	40			ns
Synchronization frequency		Fsynci	1.8		2.5	MHz
Master reassertion time	Time from last rising SYNCl edge to first unsynchronized turn-on.			650		ns
SYNCO pulse duty ratio	$C_{SYNCO(load)} = 40$ pF	D <sub>SYNCO</sub>	40		60	%
SYNCO pulse transition time (rise and fall)	$C_{SYNCO(load)} = 40$ pF, 10–90%	t <sub>tran(SYNCO)</sub>		4		ns

**FLTB**

Leakage current into FLTB pin					1	$\mu$ A
Low FLTB voltage	$R_{FLTBpullup} = V_{OUTreg}/1$ mA, $V_{OUT} > 1$ V	V <sub>FLTB</sub> low			0.4	V
Low Voltage Indicator threshold VIN decreasing VIN increasing		V <sub>LVI</sub> down V <sub>LVI</sub> up	6.8 6.95	7.1 7.47	7.4 8.0	V
Low Voltage Indicator Threshold Hysteresis		V <sub>LVI</sub> hys	0.15	0.37	0.6	V
Temperature Warning Threshold Temperature increasing Temperature decreasing		T <sub>WARN</sub> up T <sub>WARN</sub> down	140 120	158	175 170	$^\circ\text{C}$
Temperature Warning Threshold Hysteresis		T <sub>WARN</sub> hys	5		20	$^\circ\text{C}$
TWARN to TSD margin		T <sub>WARN</sub> margin	8		20	$^\circ\text{C}$

**THERMAL SHUTDOWN**

Activation Temperature		TSD	155		190	$^\circ\text{C}$
Reset temperature		TSD <sub>restart</sub>	135		185	
Hysteresis		T <sub>HYS</sub>	5		20	$^\circ\text{C}$

4. Refer to ABSOLUTE MAXIMUM RATINGS and APPLICATION INFORMATION for Safe Operating Area.
5. Performance guaranteed over the indicated operating temperature range by design and/or characterization tested at  $T_J = T_A = 25^\circ\text{C}$ . Low duty cycle pulse techniques are used during testing to maintain the junction temperature as close to ambient as possible.

APPLICATION INFORMATION

Hybrid Low-Power Mode

A high-frequency switch-mode regulator is not very efficient in light load conditions, making it difficult to achieve low-Iq requirements for sleep-mode operation. To remedy this, the NCV891x34 includes a low-Iq linear regulator that turns on at light load, while the PWM regulator turns off, ensuring a high-efficiency low-power operation. Another advantage of the low-power mode is the tight regulation free of voltage ripple usually associated with low-Iq switchers in light load conditions. In either mode, the NCV891x34 meets the 2% output voltage regulation specification.

At initial start-up the NCV891x34 will soft-start into PWM converter mode regardless of output current. During a 300 μs period, the NCV891x34 will assess the level of output current. The NCV891x34 will not make the assessment if RSTB is low. If the output current is above the  $I_{NtoL}$  threshold, the NCV891x34 will stay in PWM mode. Otherwise, the NCV891x34 will transition to low power mode.

It will stay in this low-power mode until the output current exceeds the  $I_{LIN(lim)}$  limit: it then transitions back to PWM

converter mode. This low-power mode to PWM mode transition happens within 2 μs. The transient response is not affected by the mode change.

Once the NCV891x34 has transitioned to switcher mode, a 500 μs blanking period will occur. After the blanking period, the NCV891x34 will reassess the output current level. If the output current level is below the  $I_{NtoL}$  threshold, the NCV891x34 will enter low-Iq mode.

If the NCV891x34 is in low-power mode and in normal battery range, it will transition to switcher mode when  $V_{IN}$  increases above  $V_{LINtoSW(HV)}$ , regardless of the output current. Similarly, if the NCV891x34 is in PWM mode and  $V_{IN}$  is higher than  $V_{FLDUB}$  it will not transition to low-power mode even if the output current becomes lower than  $I_{NtoL}$ .

At low input voltage, the NCV891x34 stays in low-power mode down to  $V_{LINtoSW(LV)}$  if it entered this mode while in normal battery range. However it may not enter low-power mode below 8 V depending on the charge of the bootstrap capacitor (see Bootstrap section for details).

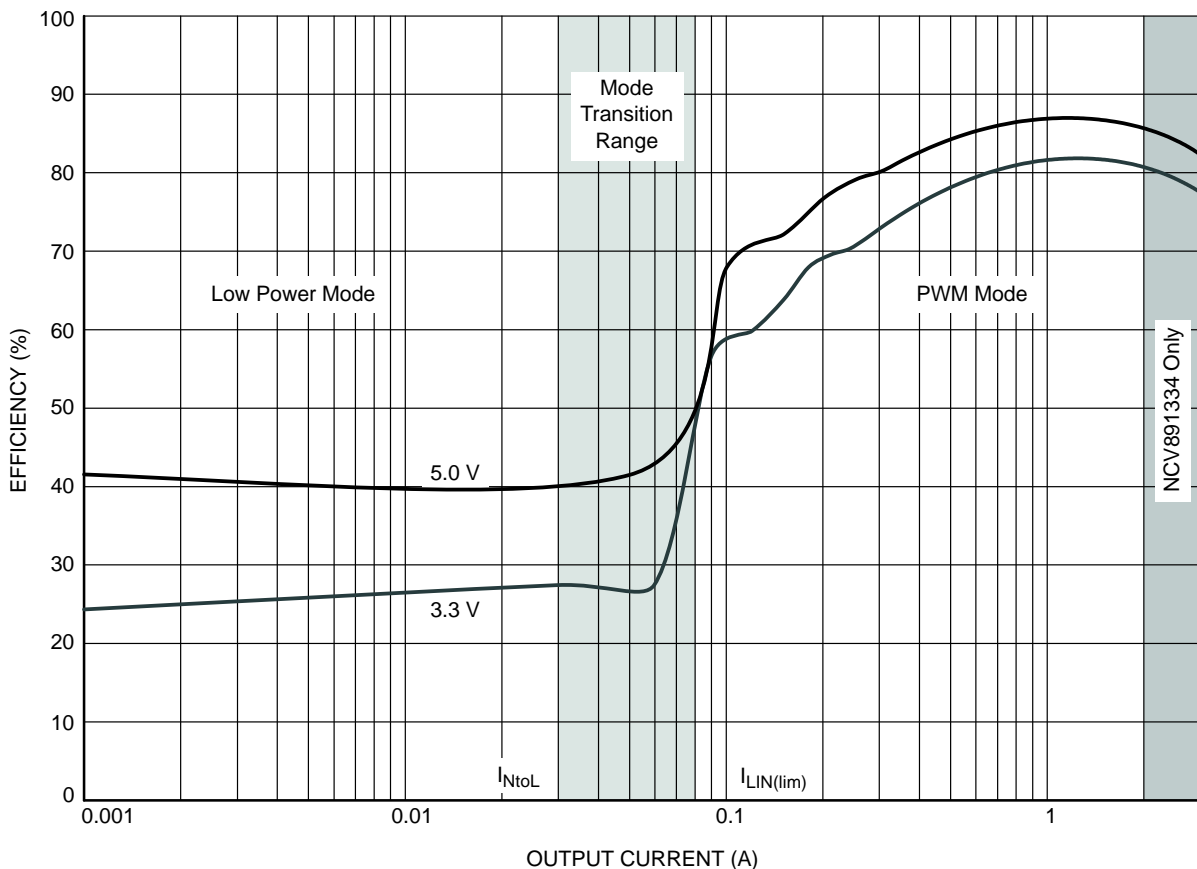

Figure 3. Measured NCV891334 Efficiency at  $V_{IN} = 12 V$  with Hybrid Low Power Mode

# NCV891234, NCV891334

## Input Voltage

An Undervoltage Lockout (UVLO) circuit monitors the input, can inhibit switching, and resets the Soft-start circuit if there is insufficient voltage for proper regulation. Depending on the output voltage and load at the output, the NCV891x34 may lose regulation and run in drop-out mode before reaching the UVLO threshold: refer to the Minimum  $V_{in}$  calculation tool for details. When the input voltage drops low enough that the part cannot regulate because it reaches its maximum duty cycle, the switching frequency is divided down by up to 4 (with a minimum frequency of 500 kHz). This helps lower the minimum voltage at which the regulator loses regulation.

While the NCV891x34 can withstand input voltages up to 45 V, an overvoltage monitoring circuit automatically terminates switching if the input voltage exceeds  $V_{OVSTP}$  (see Figure 4).

To avoid skipping switching pulses and entering an uncontrolled mode of operation, the switching frequency is reduced by a factor of 2 when the input voltage exceeds the  $V_{IN}$  Frequency Foldback threshold (see Figure 4). Frequency reduction is automatically terminated when the input voltage drops back below the  $V_{IN}$  Frequency Foldback threshold. This also helps to limit the power lost in switching and generating the drive voltage for the Power Switch.

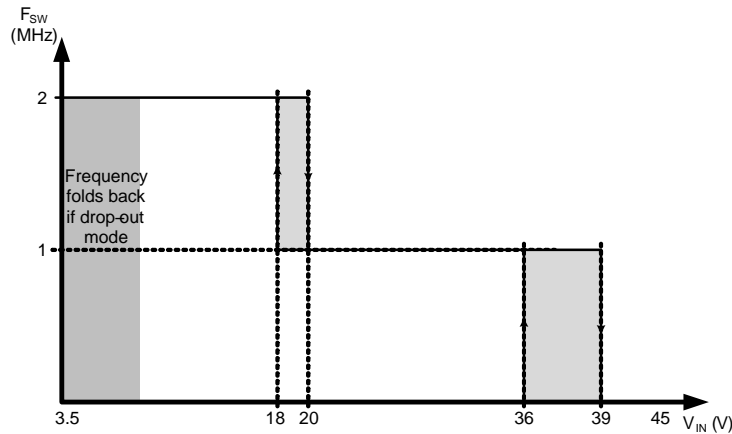

Figure 4. NCV891x34 Switching Frequency Profile vs. Input Voltage

## Soft-Start

Once the NCV891x34 is enabled or is released from a fault condition, the DRV voltage will be established and the part will enter soft-start. A soft-start circuit ramps the switching regulator error amplifier reference voltage to the final value within the soft-start completion time,  $t_{(ss)}$ . During soft-start, the average switching frequency is lower until the output voltage approaches regulation.

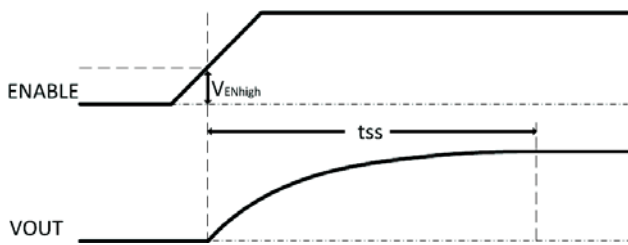

Figure 5. NCV891x34 Soft-start

## Slope Compensation

A fixed slope compensation signal is generated internally and added to the sensed current to avoid increased output voltage ripple due to bifurcation of inductor ripple current at duty cycles above 50%. The fixed amplitude of the slope compensation signal requires the inductor to be greater than a minimum value, depending on output voltage, in order to avoid sub-harmonic oscillations. The recommended inductor values are 2.2 or 3.3  $\mu\text{H}$ , although higher values are possible.

## Current Limiting

Due to the ripple on the inductor current, the average output current of a buck converter is lower than the peak current setpoint of the regulator. Figure 6 shows – for a 2.2  $\mu\text{H}$  inductor – how the variation of inductor peak current with input voltage affects the maximum DC current the NCV891x34 can deliver to a load.

## NCV891234, NCV891334

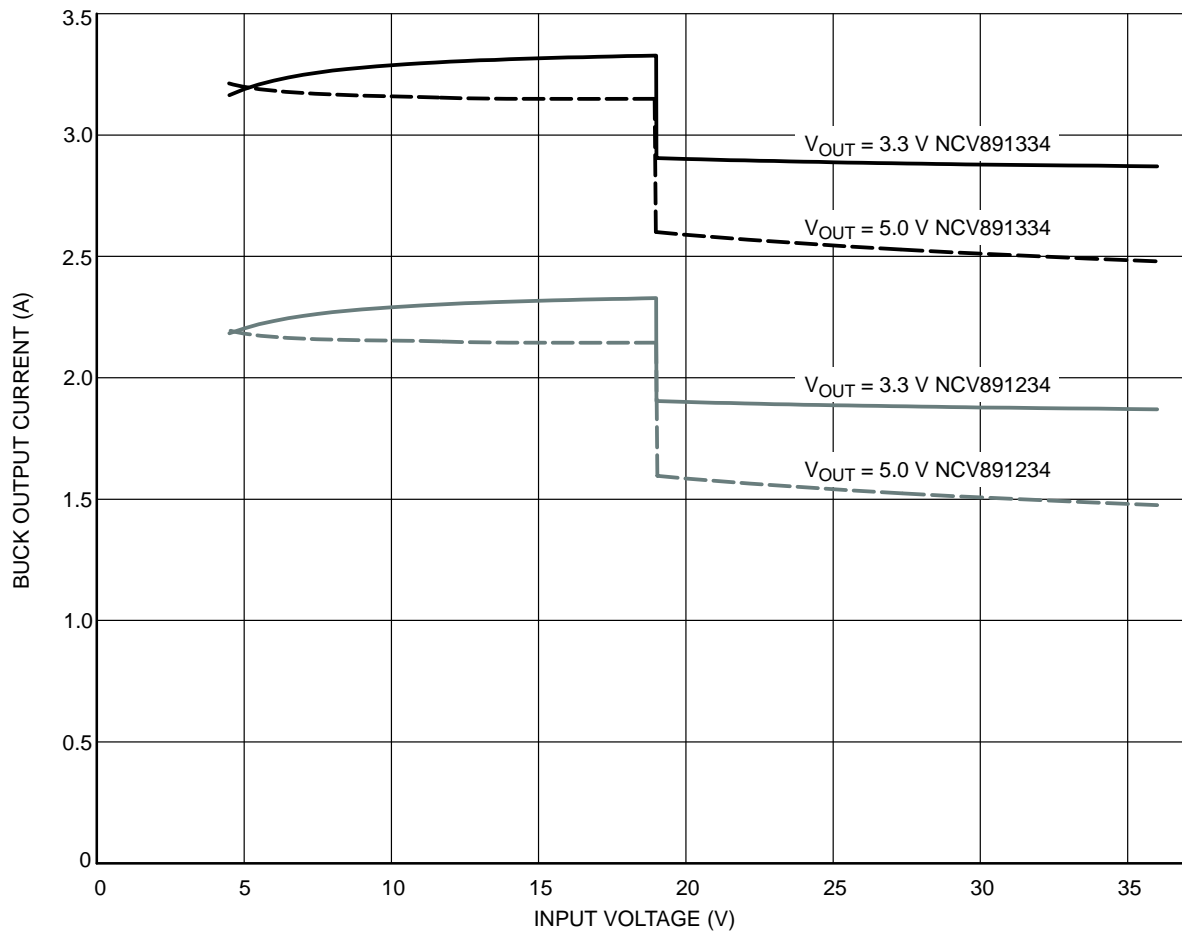

Figure 6. Worst Case NCV891x34 Load Current Capability with a 2.2  $\mu$ H Inductor

### Short Circuit Protection

During severe output overloads or short circuits, the NCV891x34 automatically reduces its switching frequency to  $F_{SWAF}$  under normal operating conditions and to  $F_{SWAFHV}$  during foldback. This creates duty cycles small enough to limit the peak current in the power components, while maintaining the ability to automatically reestablish the output voltage if the overload is removed.

In more severe short-circuit conditions where the inductor current is still too high after the switching frequency has fully folded back, the regulator enters a hiccup mode that further reduces the power dissipation and protects the system. In hiccup mode, the frequency is further reduced to  $F_{SWHIC}$ .

### RESET function

The RSTB pin is pulled low when the output voltage falls below 7.5% of the nominal regulation level, and floats when the output is properly regulated. A pull-up resistor tied to the output is needed to generate a logic high signal on this open drain pin. The pin can be left unconnected when not used.

When the output voltage drops out of regulation, the pin goes low after a short noise-filtering delay ( $t_{filter}$ ). It stays

low for a 16 ms delay time after the output goes back to regulation, simplifying the connection to a micro-controller.

The RSTB pin is also pulled low immediately in case of VIN overvoltage, Thermal shutdown, VIN UVLO or DRV UVLO.

### Feedback Loop

All components of the feedback loop (output voltage sensing, error amplifier and compensation) are integrated inside the NCV891x34, and are optimized to ensure regulation and sufficient phase and gain margin for the recommended conditions of operation.

Recommended conditions and components:

- Input: car battery
- Output: 3.3 V or 5 V, with output current up to 3 A
- Output capacitor: one to three parallel ceramic 10  $\mu$ F capacitors
- Inductor: 2.2  $\mu$ H to 3.3  $\mu$ H

With these operating conditions and components, the open loop transfer function has a phase margin greater than 50°.

# NCV891234, NCV891334

## Bootstrap

At the DRV pin an internal regulator provides a ground-referenced voltage to an external capacitor ( $C_{DRV}$ ), to allow fast recharge of the external bootstrap capacitor ( $C_{BST}$ ) used to supply power to the power switch gate driver. If the voltage at the DRV pin goes below the DRV UVLO Threshold  $V_{DRVSTB}$  switching is inhibited and the Soft-start circuit is reset, until the DRV pin voltage goes back up above  $V_{DRVSTT}$ .

The NCV891x34 monitors the bootstrap capacitor, and always ensures it stays charged no matter what the operating conditions are. As a result, the additional charging current for the bootstrap capacitor may prevent the regulator from entering Low-Iq mode at low input voltage. Practically, the 5 V output version does not enter Low-Iq mode for input voltages below 8 V.

## Enable

The NCV891x34 is designed to accept either a logic level signal or battery voltage as an Enable signal. However if voltages above 40 V are expected, EN should be tied to VIN through a 10 k $\Omega$  resistor in order to limit the current flowing into the overvoltage protection of the pin.

EN low induces a shutdown mode which shuts off the regulator and minimizes its supply current to 9  $\mu$ A typical by disabling all functions.

Upon enabling, voltage is established at the DRV pin, followed by a soft-start of the switching regulator output.

## Synchronization

Two NCV891x34 can be synchronized out-of-phase to one another by connecting the SYNCO pin of one to the SYNCI pin of the other. Any number of NCV891x34 can also be synchronized to an external clock.

If a part does not have its switching frequency controlled by the SYNCI input, it drives the SYNCO pin low when it turns on the power switch, and drives it high half a switching period later.

When the switching frequency is controlled by the SYNCI input, the SYNCO pin is held low.

Synchronization starts within 2.5 ms of the RSTB Low-to-High transition. A rising edge at the SYNCI pin causes an NCV891x34 to immediately turn on the power switch. If another rising edge does not arrive at the SYNCI pin within the Master Reassertion Time, the NCV891x34 controls its own switching frequency, allowing uninterrupted operation in the event that the clock is turned off.

If internal conditions or excessive input voltage cause an NCV891x34 to fold back its switching frequency, the main oscillator switching frequency is no longer derived from the frequency received at the SYNCI pin. Under these conditions, the SYNCO pin is held low.

An external pulldown resistor is not required at the SYNCI pin if it is unused.

The SYNCO pin is a buffered output (no pull-up resistor needed), and must be left unconnected when not used.

## FLTB Function

The FLTB pin is pulled low when one of the following conditions is detected:

- Low Input Voltage (below the LVI threshold, see parametric table)
- High Temperature (above the TWARN threshold, see parametric table)

A pull-up resistor tied to the output is needed to generate a logic high signal on this open drain pin. The pin can be left unconnected when not used.

There is a short noise-filtering delay ( $t_{filter}$ ) to avoid false reporting.

## Thermal Shutdown

A thermal shutdown circuit inhibits switching, resets the Soft-start circuit, and removes DRV voltage if internal temperature exceeds a safe level. Switching is automatically restored when temperature returns to a safe level.

## Exposed Pad

The exposed pad (EPAD) on the back of the package must be electrically connected to the electrical ground (GND pin) for proper, noise-free operation.

## ORDERING INFORMATION

Device	Output	Package	Shipping†
NCV891234MW50R2G	5.0 V	DFN-12 With wettable flanks	3000 / Tape & Reel
NCV891234MW33R2G	3.3 V		
NCV891334MW50R2G	5.0 V		
NCV891334MW33R2G	3.3 V		

†For information on tape and reel specifications, including part orientation and tape sizes, please refer to our Tape and Reel Packaging Specifications Brochure, BRD8011/D.

# MECHANICAL CASE OUTLINE

## PACKAGE DIMENSIONS

ON Semiconductor®

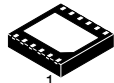

SCALE 2:1

DFN12, 4x4, 0.65P  
CASE 506CE  
ISSUE O

DATE 23 FEB 2012

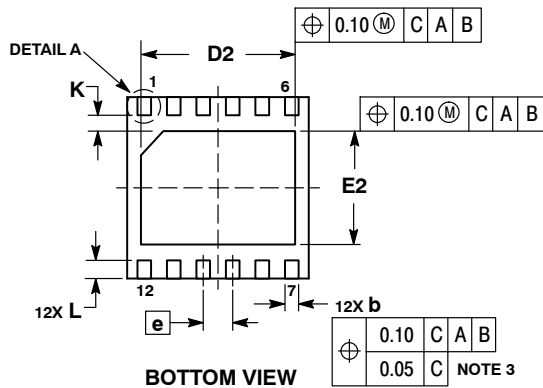
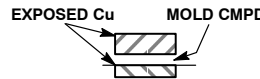
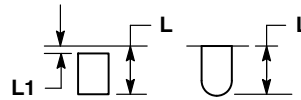
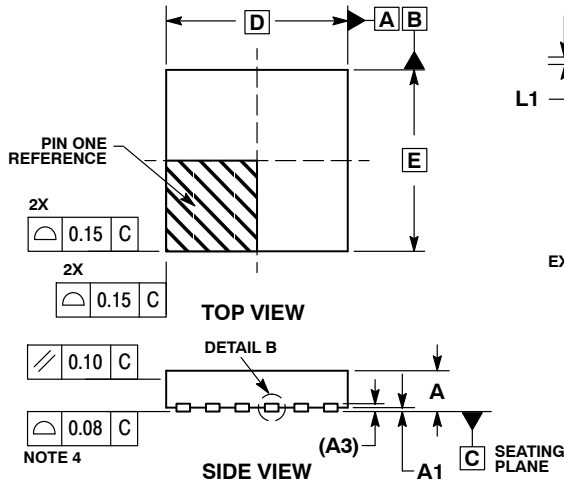

### SOLDERING FOOTPRINT\*

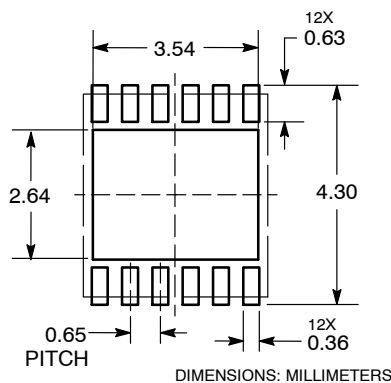

### NOTES:

1. DIMENSIONS AND TOLERANCING PER ASME Y14.5M, 1994.
2. CONTROLLING DIMENSION: MILLIMETERS.
3. DIMENSION b APPLIES TO PLATED TERMINAL AND IS MEASURED BETWEEN 0.15 AND 0.30 MM FROM TERMINAL.
4. COPLANARITY APPLIES TO THE EXPOSED PAD AS WELL AS THE TERMINALS.

MILLIMETERS		
DIM	MIN	MAX
A	0.80	1.00
A1	0.00	0.05
A3	0.20	REF
b	0.25	0.35
D	4.00	BSC
D2	3.30	3.50
E	4.00	BSC
E2	2.40	2.60
e	0.65	BSC
K	0.20	---
L	0.30	0.50
L1	---	0.15

### GENERIC MARKING DIAGRAM\*

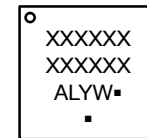

- XXXXXX= Specific Device Code  
 A = Assembly Location  
 L = Wafer Lot  
 Y = Year  
 W = Work Week  
 ▪ = Pb-Free Package

(\*Note: Microdot may be in either location)

\*This information is generic. Please refer to device data sheet for actual part marking. Pb-Free indicator, "G" or microdot "▪", may or may not be present.

\*For additional information on our Pb-Free strategy and soldering details, please download the ON Semiconductor Soldering and Mounting Techniques Reference Manual, SOLDERRM/D.

<b>DOCUMENT NUMBER:</b>	<b>98AON78622E</b>	Electronic versions are uncontrolled except when accessed directly from the Document Repository. Printed versions are uncontrolled except when stamped "CONTROLLED COPY" in red.
<b>DESCRIPTION:</b>	<b>12 PIN DFN, 4X4, 0.65P</b>	<b>PAGE 1 OF 1</b>

ON Semiconductor and ON are trademarks of Semiconductor Components Industries, LLC dba ON Semiconductor or its subsidiaries in the United States and/or other countries. ON Semiconductor reserves the right to make changes without further notice to any products herein. ON Semiconductor makes no warranty, representation or guarantee regarding the suitability of its products for any particular purpose, nor does ON Semiconductor assume any liability arising out of the application or use of any product or circuit, and specifically disclaims any and all liability, including without limitation special, consequential or incidental damages. ON Semiconductor does not convey any license under its patent rights nor the rights of others.

ON Semiconductor and  are trademarks of Semiconductor Components Industries, LLC dba ON Semiconductor or its subsidiaries in the United States and/or other countries. ON Semiconductor owns the rights to a number of patents, trademarks, copyrights, trade secrets, and other intellectual property. A listing of ON Semiconductor's product/patent coverage may be accessed at [www.onsemi.com/site/pdf/Patent-Marking.pdf](http://www.onsemi.com/site/pdf/Patent-Marking.pdf). ON Semiconductor reserves the right to make changes without further notice to any products herein. ON Semiconductor makes no warranty, representation or guarantee regarding the suitability of its products for any particular purpose, nor does ON Semiconductor assume any liability arising out of the application or use of any product or circuit, and specifically disclaims any and all liability, including without limitation special, consequential or incidental damages. Buyer is responsible for its products and applications using ON Semiconductor products, including compliance with all laws, regulations and safety requirements or standards, regardless of any support or applications information provided by ON Semiconductor. "Typical" parameters which may be provided in ON Semiconductor data sheets and/or specifications can and do vary in different applications and actual performance may vary over time. All operating parameters, including "Typicals" must be validated for each customer application by customer's technical experts. ON Semiconductor does not convey any license under its patent rights nor the rights of others. ON Semiconductor products are not designed, intended, or authorized for use as a critical component in life support systems or any FDA Class 3 medical devices or medical devices with a same or similar classification in a foreign jurisdiction or any devices intended for implantation in the human body. Should Buyer purchase or use ON Semiconductor products for any such unintended or unauthorized application, Buyer shall indemnify and hold ON Semiconductor and its officers, employees, subsidiaries, affiliates, and distributors harmless against all claims, costs, damages, and expenses, and reasonable attorney fees arising out of, directly or indirectly, any claim of personal injury or death associated with such unintended or unauthorized use, even if such claim alleges that ON Semiconductor was negligent regarding the design or manufacture of the part. ON Semiconductor is an Equal Opportunity/Affirmative Action Employer. This literature is subject to all applicable copyright laws and is not for resale in any manner.

## PUBLICATION ORDERING INFORMATION

### LITERATURE FULFILLMENT:

Email Requests to: [orderlit@onsemi.com](mailto:orderlit@onsemi.com)

ON Semiconductor Website: [www.onsemi.com](http://www.onsemi.com)

### TECHNICAL SUPPORT

North American Technical Support:  
Voice Mail: 1 800-282-9855 Toll Free USA/Canada  
Phone: 011 421 33 790 2910

Europe, Middle East and Africa Technical Support:

Phone: 00421 33 790 2910

For additional information, please contact your local Sales Representative

