



2400W Power Supply with Single Output

RSP-2400 series

Dimension

L	*	W	*	H	
278	*	177.8	*	63.5(2U)	mm
10.9	*	7	*	2.5 (2U)	inch



Features

- AC input 180~264VAC
- Built-in active PFC function
- High efficiency up to 91.5%
- Forced air cooling by built-in DC fan
- Output voltage programmable
- Active current sharing up to 7200W (2+1)
- Built-in remote ON-OFF control / remote sense / auxiliary power / power OK signal
- Protections: Short circuit / Overload / Over voltage / Over temperature
- Optional conformal coating
- 5 years warranty

Applications

- Factory control or automation apparatus
- Test and measurement instrument
- Laser related machine
- Burn-in facility
- Digital broadcasting
- RF application

GTIN CODE

MW Search: <https://www.meanwell.com/serviceGTIN.aspx>

Description

RSP-2400 is a 2.4KW single output enclosed type AC/DC power supply. This series operates for 180~264VAC input voltage and offers the models with the DC output mostly demanded from the industry. Each model is cooled by the built-in fan with fan speed control, working for the temperature up to 70°C. Moreover, RSP-2400 provides vast design flexibility by equipping various built-in functions such as the output programming, active current sharing, remote ON-OFF control, auxiliary power, etc.

Model Encoding / Order Information

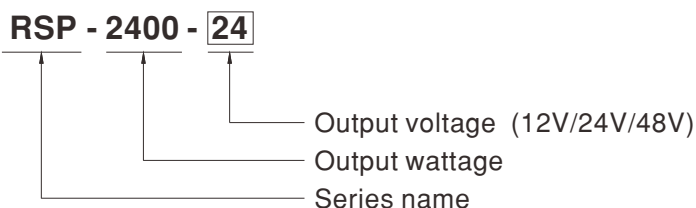

**SPECIFICATION**

MODEL		RSP-2400-12	RSP-2400-24	RSP-2400-48	
OUTPUT	DC VOLTAGE	12V	24V	48V	
	RATED CURRENT	166.7A	100A	50A	
	CURRENT RANGE	0 ~ 166.7A	0 ~ 100A	0 ~ 50A	
	RATED POWER	2000.4W	2400W	2400W	
	RIPPLE & NOISE (max.) <small>Note.2</small>	150mVp-p	150mVp-p	200mVp-p	
	VOLTAGE ADJ. RANGE	10.8 ~ 13.2V	22 ~ 28V	43 ~ 56V	
	VOLTAGE TOLERANCE <small>Note.3</small>	± 1.0%	± 1.0%	± 1.0%	
	LINE REGULATION	± 0.5%	± 0.5%	± 0.5%	
	LOAD REGULATION	± 0.5%	± 0.5%	± 0.5%	
	SETUP, RISE TIME	1000ms, 80ms at full load			
HOLD UP TIME (Typ.)	12ms at full load				
INPUT	VOLTAGE RANGE	180 ~ 264VAC    254 ~ 370VDC			
	FREQUENCY RANGE	47 ~ 63Hz			
	POWER FACTOR (Typ.)	0.95/230VAC at full load			
	EFFICIENCY (Typ.)	88%	90.5%	91.5%	
	AC CURRENT (Typ.)	15.5A/180VAC    12A/230VAC			
	INRUSH CURRENT (Typ.)	60A/230VAC			
	LEAKAGE CURRENT	<2.0mA / 240VAC			
PROTECTION	OVERLOAD (OLP)	100 ~ 112% rated output power User adjustable continuous constant current limiting or constant current limiting with delay shutdown after 5 seconds, re-power on to recover			
	OVER VOLTAGE	13.8 ~ 16.8V	28.8 ~ 33.6V	57.6 ~ 67.2V	
	OVER TEMPERATURE	Shut down o/p voltage, recovers automatically after temperature goes down Protection type : Shut down o/p voltage, re-power on to recover			
FUNCTION	OUTPUT VOLTAGE	2.4 ~ 13.2V	4.8 ~ 28V	9.6 ~ 56V	
	PROGRAMMABLE(PV)	Please refer to the Function Manual.			
	CURRENT SHARING	Up to 7200W or (2+1) units. Please refer to the Function Manual.			
	AUXILIARY POWER	12V@0.1A(Only for Remote ON-OFF control)			
	REMOTE ON-OFF CONTROL	Please refer to the Function Manual			
	REMOTE SENSE	Compensate voltage drop on the load wiring up to 0.25V. Please refer to the Function Manual.			
	ALARM SIGNAL OUTPUT	Power OK signal. Please refer to the Function Manual			
ENVIRONMENT	WORKING TEMP.	-20 ~ +70°C (Refer to "Derating Curve")			
	WORKING HUMIDITY	20 ~ 90% RH non-condensing			
	STORAGE TEMP., HUMIDITY	-40 ~ +85°C, 10 ~ 95% RH non-condensing			
	TEMP. COEFFICIENT	± 0.05%/°C (0 ~ 50°C)			
	VIBRATION	10 ~ 500Hz, 2G 10min./1cycle, 60min. each along X, Y, Z axes			
SAFETY & EMC <small>(Note 4)</small>	SAFETY STANDARDS	UL62368-1, CSA C22.2 No. 62368-1, TUV BS EN/EN62368-1, BSMI CNS15598-1, AS/NZS62368.1, IS13252(Part1)/IEC60950-1, EAC TP TC 004 approved			
	WITHSTAND VOLTAGE	I/P-O/P:3KVAC    I/P-FG:2KVAC    O/P-FG:0.5KVAC			
	ISOLATION RESISTANCE	I/P-O/P, I/P-FG, O/P-FG:100M Ohms / 500VDC / 25°C / 70% RH			
	EMC EMISSION	Parameter	Standard	Test Level / Note	
		Conducted	BS EN/EN55032 (CISPR32), CNS15936	Class B	
		Radiated	BS EN/EN55032 (CISPR32), CNS15936	Class A	
		Harmonic Current	BS EN/EN61000-3-2	-----	
		Voltage Flicker	BS EN/EN61000-3-3	-----	
	EMC IMMUNITY	BS EN/EN55035, BS EN/EN61000-6-2, BSMI CNS13438			
		Parameter	Standard	Test Level / Note	
		ESD	BS EN/EN61000-4-2	Level 3, 8KV air ; Level 2, 4KV contact	
		Radiated	BS EN/EN61000-4-3	Level 3	
		EFT / Burst	BS EN/EN61000-4-4	Level 3	
		Surge	BS EN/EN61000-4-5	Level 3, 2KV/Line-Earth ; Level 2, 1KV/Line-Line	
		Conducted	BS EN/EN61000-4-6	Level 3	
Magnetic Field		BS EN/EN61000-4-8	Level 4		
Voltage Dips and Interruptions		BS EN/EN61000-4-11	>95% dip 0.5 periods, 30% dip 25 periods, >95% interruptions 250 periods		
OTHERS	MTBF	692.3K hrs min.    Telcordia SR-332 (Bellcore) ; 83.9K hrs min.    MIL-HDBK-217F (25°C)			
	DIMENSION	278*177.8*63.5mm (L*W*H)			
	PACKING	3.3Kg; 4pcs/14.2Kg/2.04CUFT			
NOTE	<p>1. All parameters NOT specially mentioned are measured at 230VAC input, rated load and 25°C of ambient temperature.</p> <p>2. Ripple &amp; noise are measured at 20MHz of bandwidth by using a 12" twisted pair-wire terminated with a 0.1uf &amp; 47uf parallel capacitor.</p> <p>3. Tolerance : includes set up tolerance, line regulation and load regulation.</p> <p>4. The power supply is considered a component which will be installed into a final equipment. All the EMC tests are been executed by mounting the unit on a 720mm*360mm metal plate with 1mm of thickness. The final equipment must be re-confirmed that it still meets EMC directives. For guidance on how to perform these EMC tests, please refer to "EMI testing of component power supplies." (as available on <a href="https://www.meanwell.com/Upload/PDF/EMI_statement_en.pdf">https://www.meanwell.com/Upload/PDF/EMI_statement_en.pdf</a>)</p> <p>5. The ambient temperature derating of 3.5°C/1000m with fanless models and of 5°C/1000m with fan models for operating altitude higher than 2000m(6500ft).</p> <p>※ Product Liability Disclaimer : For detailed information, please refer to <a href="https://www.meanwell.com/serviceDisclaimer.aspx">https://www.meanwell.com/serviceDisclaimer.aspx</a></p>				

■ Block Diagram

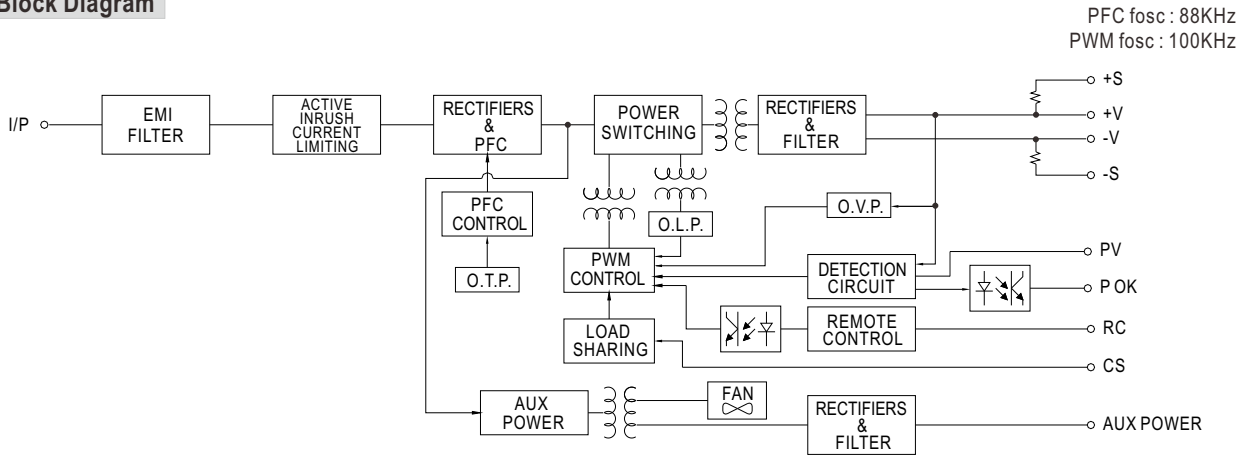

■ Static Characteristics

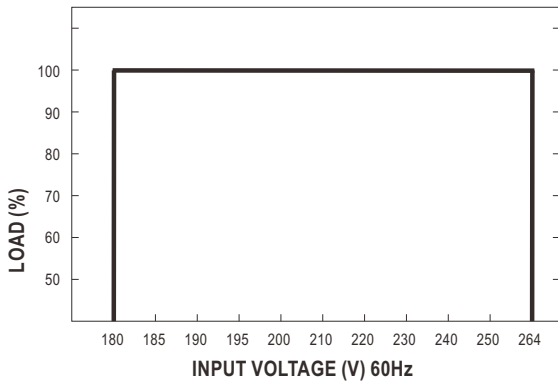

MODEL	12V	24V	48V
INPUT	2000.4W	2400W	2400W
180~264VAC	166.7A	100A	50A

■ Derating Curve

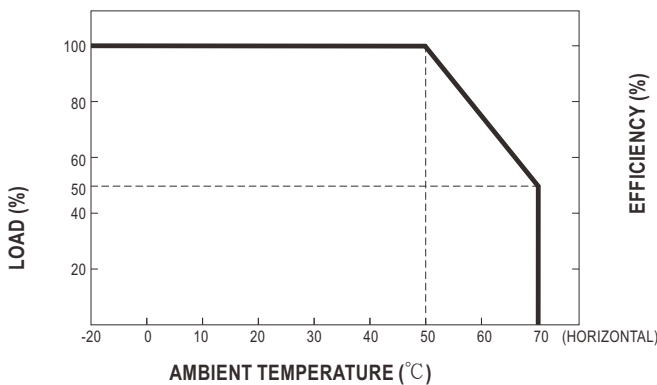

■ Efficiency vs Load (48V Model)

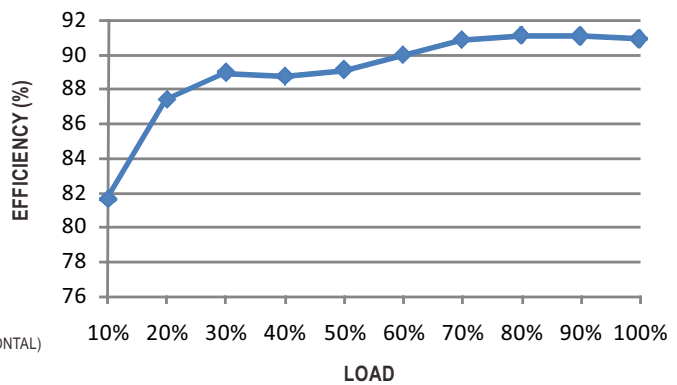

※ The curve above is measured at 230VAC.

◎ Load (%) typically represents the output power.  
However, when the PV function is involved, Load (%) changes to indicate the percentage of the output current.  
For example, with the PV function used for the RSP-2400-24, 80A corresponds to 80% of the load.

■ Function Manual

1. Remote Sense

※ The Remote Sense compensates voltage drop on the load wiring up to 0.25V

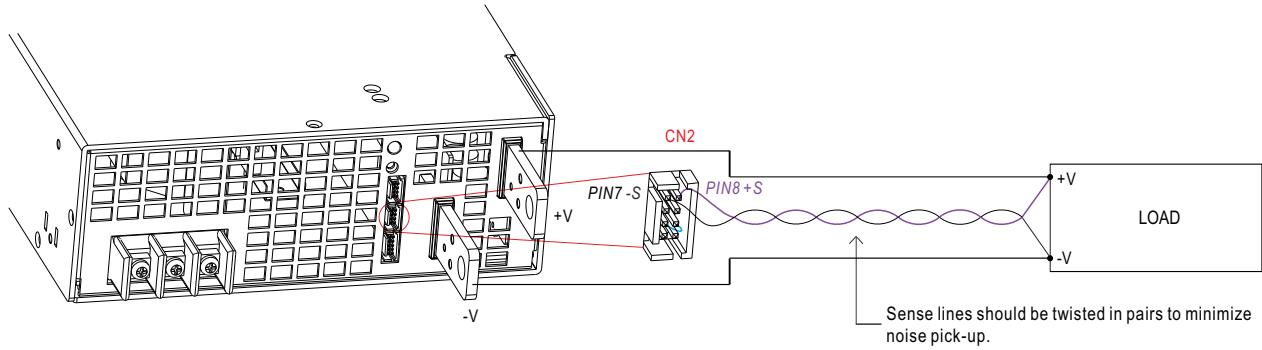

※ Caution: The power supply, by factory default (also the assumption for other sections), is shipped with, -S & -V on CN2, as well as +S & +V, shorted by connector. When activating the Remote Sense, the +S signal should be connected to the positive terminal of the load whereas -S signal to the negative terminal of the load.

2. Output Voltage Programming (or, PV / remote voltage programming / remote adjust / margin programming / dynamic voltage trim)

※ In addition to the adjustment via the built-in potentiometer, the output voltage can be trimmed to 20~110% (Typ.) of the nominal voltage by applying EXTERNAL VOLTAGE.

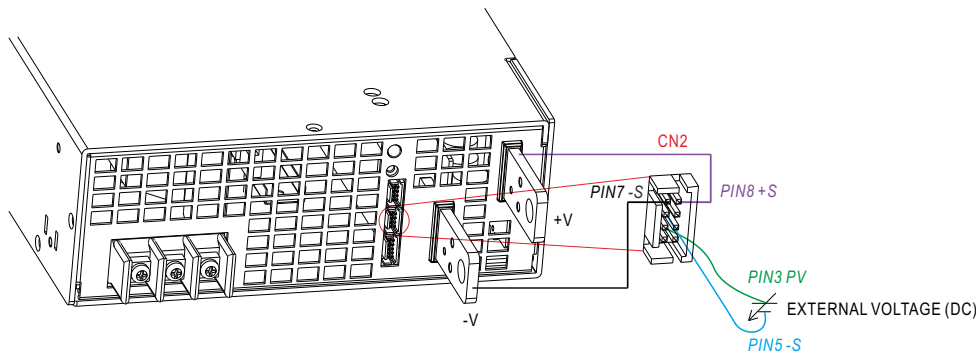

◎ Connecting an external DC source between PV & -S on CN2, and +S & +V, -S & -V also need to be connected as exhibited above.

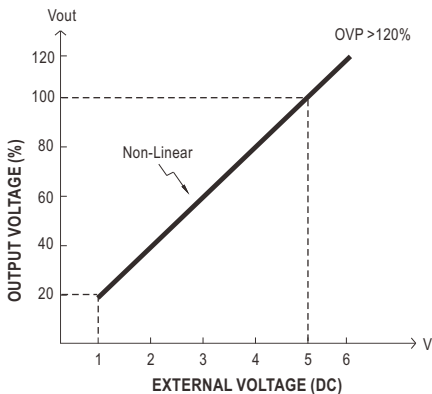

MODEL	12V	24V	48V
PV Range	2.4 ~ 13.2V	4.8 ~ 28V	9.6 ~ 56V

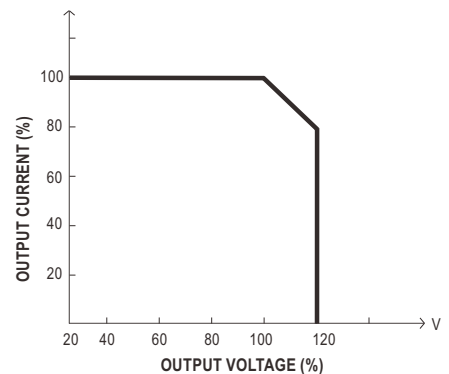

◎ Please do not adopt PWM signal as the EXTERNAL VOLTAGE.

◎ The rated current should change with the Output Voltage Programming accordingly.

※ Caution: (1) By factory default, the Output Voltage Programming is not activated, and PV (PIN3) and PS (PIN4) of CN2 are shorted by connector. Whenever this function is not needed to activate, as assumed in other sections' diagrams, please keep PV (PIN3) and PS (PIN4) of CN2 shorted; otherwise, the power supply will have no output.

(2) PV (PIN3) and PS (PIN4) of CN1 or CN2 must be disconnected if "Output Voltage Programming" function is used; otherwise, the internal electrical components may be damaged, and the power supply unit may thus be out of order.

### 3. Remote ON-OFF

※ Remote ON-OFF is activated by the configuration with respect to CN1, CN2 and CN3 as shown in the following diagram.

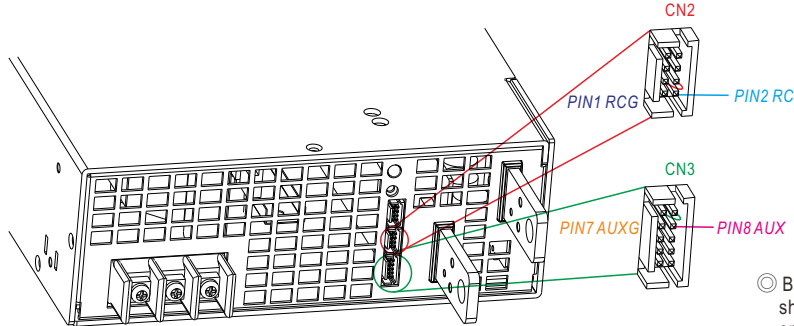

◎ By factory default, PV(PIN3) and PS(PIN4) on CN2 are shorted by connector; likewise, OLP(PIN9) and OL-SD(PIN10) on CN3 are shorted when shipped.

Example 3.2(A): Using external voltage source

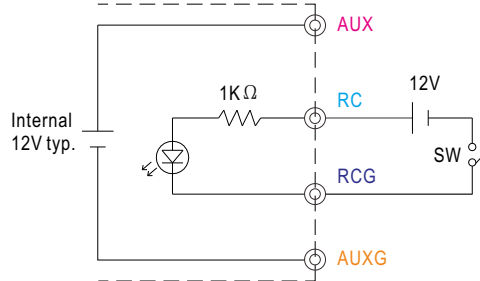

Example 3.2(B): Using internal 12V auxiliary output

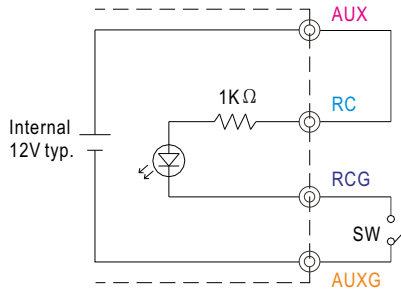

Example 3.2(C): Using internal 12V auxiliary output

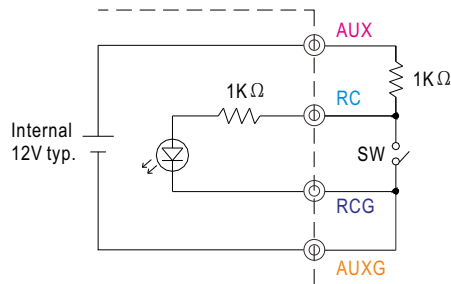

◎ Connection Method

		Example 3.2(A)	Example 3.2(B)	Example 3.2(C)
SW Logic	Power supply output ON	SW Open	SW Open	SW Close
	Power supply output OFF	SW Close	SW Close	SW Open

**4. Alarm Signal Output**

※ Alarm signal is sent out through "P OK" & "P OK GND" and P OK2 & P OK GND2 pins on CN3. Please acknowledge an external voltage source is required for this function.

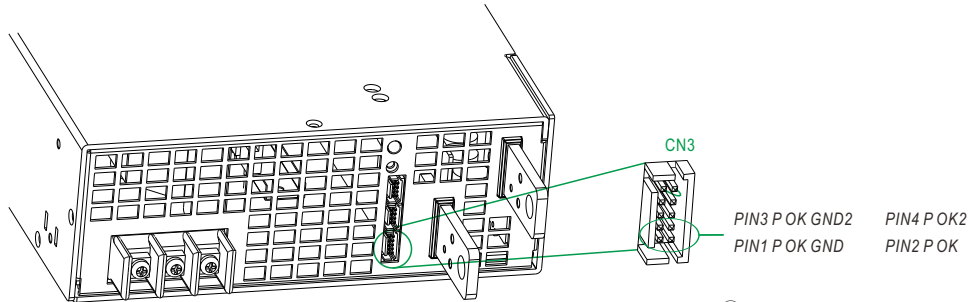

◎ By factory default, OLP(PIN9) and OL-SD(PIN10) on CN3 are shorted by connector when shipped.

Function	Description	Output of alarm(P OK, Relay Contact)	Output of alarm(P OK2, TTL Signal)
P OK	The signal is "Low" when the power supply is above 80% of the rated output voltage, or, say, Power OK	Low (0.5V max at 500mA)	Low (0.5V max at 10mA)
	The signal turns to be "High" when the power supply is under 80% of the rated output voltage, or, say, Power Fail	High or open (External applied voltage, 500mA max.)	High or open (External applied voltage, 10mA max.)

Table 4.1 Explanation of alarm

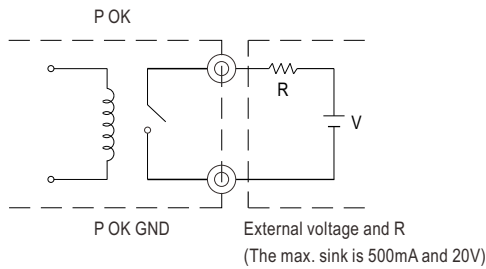

Fig. 4.1 Internal circuit of P OK (Relay, total is 10W)

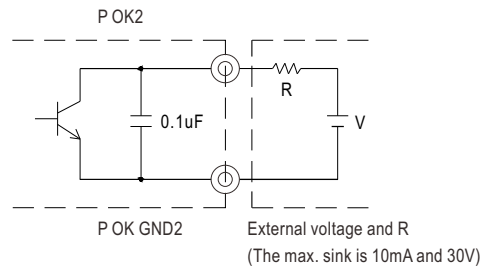

Fig. 4.2 Internal circuit of P OK2 (Open collector method)

**5. Select Overload Protection Type**

- (1) Insert the shorting connector on CN3 that is shown in Fig 5.1, the Overload Protection Type will be "constant current limiting with delay shutdown after 5 seconds, re-power on to recover". This is the factory default.
- (2) Remove the shorting connector on CN3 that is shown in Fig 5.2, the Overload Protection Type will be "continuous constant current limiting".

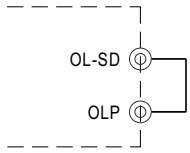

Fig. 5.1 Insert the CN3  
Overload Protection Type : constant current limiting with delay shutdown after 5 seconds

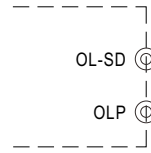
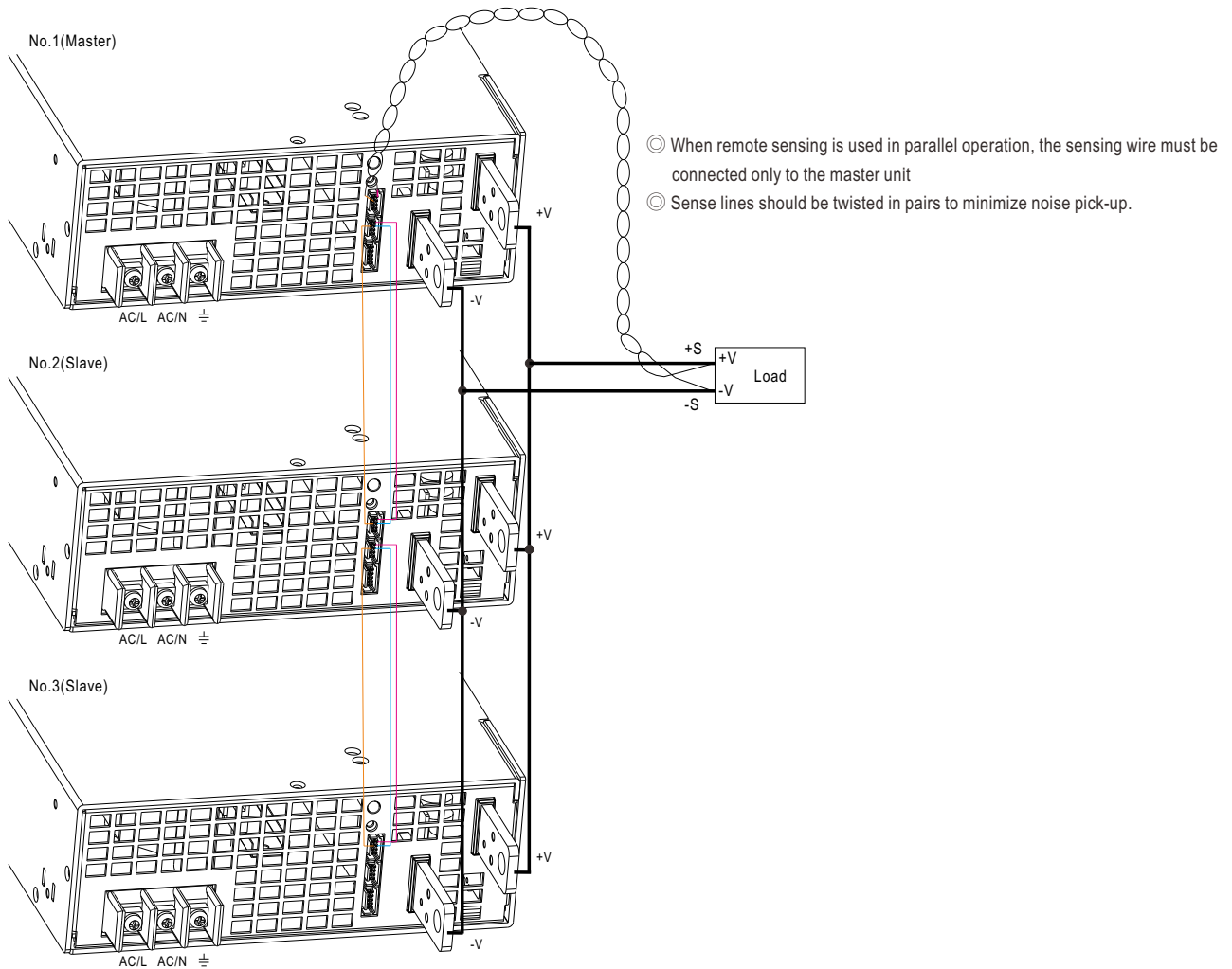

Fig. 5.2 Remove the CN3  
Overload Protection Type : constant current limiting

**6. Current Sharing with Remote Sense**

RSP-2400 has the built-in active current sharing function and can be connected in parallel, up to 3 units, to provide higher output power as exhibited below :

- ※ The power supplies should be paralleled using short and large diameter wiring and then connected to the load.
- ※ Difference of output voltages among parallel units should be less than 0.2V.
- ※ The total output current must not exceed the value determined by the following equation:  
Maximum output current at parallel operation = (Rated current per unit) × (Number of unit) × 0.9
- ※ When the total output current is less than 3% of the total rated current, or say (3% of Rated current per unit) × (Number of unit) the current shared among units may not be fully balanced.



- ◎ +S, -S and CS on CN1 or CN2 are connected mutually in parallel.
- ◎ Under parallel operation, the "output voltage programming" function is not available.

### 7. Three Phase Connect

Users can exploit three units of RSP-2400(unit 1, unit 2, unit 3) to work with 3  $\psi$  power system. Please refer to following diagrams for configuration.

※FIG. A: 3  $\psi$  3 wire 220VAC SYSTEM

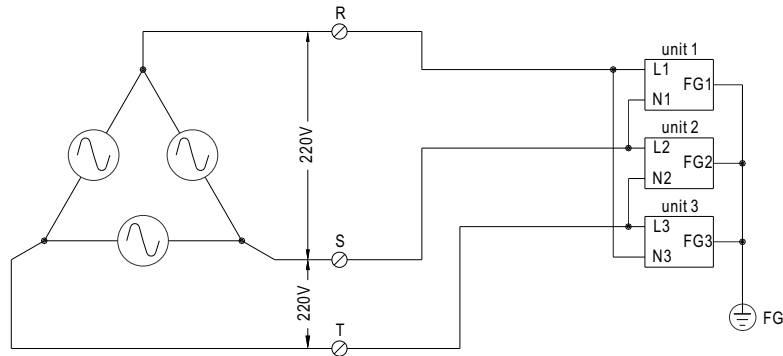

※FIG. B: 3  $\psi$  4 wire 220/380VAC SYSTEM

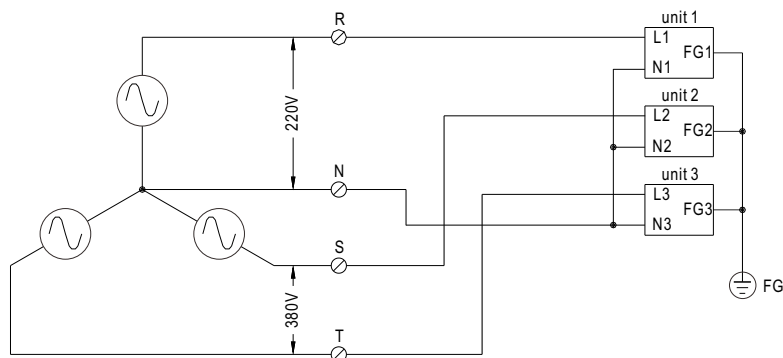

※FIG. C: 3  $\psi$  4 wire 190/110VAC SYSTEM

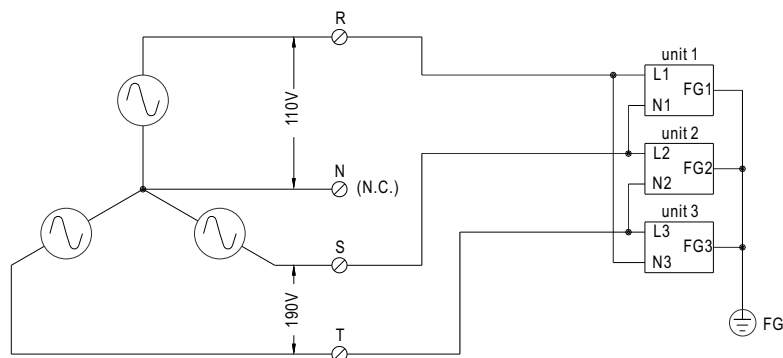

### Mechanical Specification

(Unit: mm , tolerance  $\pm 0.5\text{mm}$ )

Case No.982B

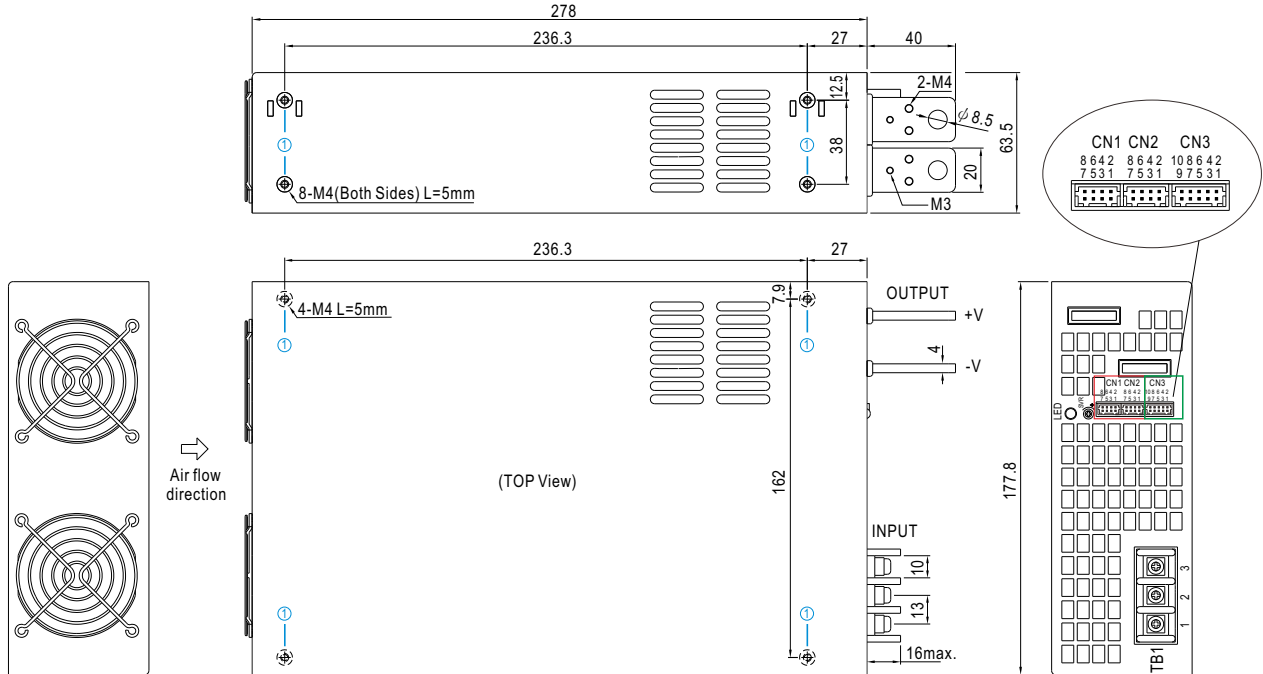

### Mounting Instruction

Hole No.	Recommended Screw Size	MAX. Penetration Depth L	Recommended mounting torque
①	M4	5mm	7~10Kgf-cm

※ Control Pin No. Assignment (CN1,CN2) : HRS DF11-8DP-2DS or equivalent

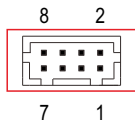

Mating Housing	HRS DF11-8DS or equivalent
Terminal	HRS DF11-8**SC or equivalent

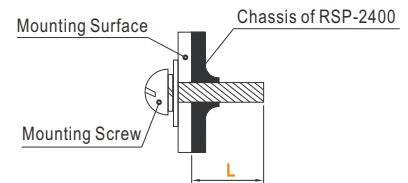

◎ CN1 and CN2 are connected internally.

Pin No.	Function	Description
1	RCG	Remote ON-OFF Ground
2	RC	Remote ON-OFF
3	PV	Connection for output voltage programming
4	PS	Reference Voltage Terminal
5,7	-S	Negative sensing for remote sense
6	CS(Current Share)	Current Share
8	+S	Positive sensing for remote sense

※Control Pin No. Assignment (CN3) : HRS DF11-10DP-2DS or equivalent

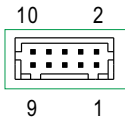

Mating Housing	HRS DF11-10DS or equivalent
Terminal	HRS DF11-10SC or equivalent

Pin No.	Function	Description
1	P OK GND	Power OK Ground
2	P OK	Power OK Signal (Relay Contact)
3	P OK GND2	Power OK Ground
4	P OK2	Power OK Signal (TTL Signal)
5	RCG	Remote ON-OFF Ground
6	RC	Remote ON-OFF
7	AUXG	Auxiliary Ground
8	AUX	Auxiliary Output
9	OLP	Overload(OLP) type select
10	OL-SD	

※AC Input Terminal Pin No. Assignment

Pin No.	Assignment	Diagram	Maximum mounting torque
1	AC/L		18Kgf-cm
2	AC/N		
3	FG $\perp$		

■ Installation Manual

Please refer to : <http://www.meanwell.com/manual.html>