

SERIES 80 Mighty Mouse connectors Crimp Tools and Positioners



MINIATURE ADJUSTABLE CRIMP TOOLS



809-015

These crimp tools perform precision eight indent crimps for gas-tight wire terminations and excellent tensile strength. Adjustment wheel has 8 settings. Ratchet mechanism prevents improper crimps. Use with bayonet-type positioners. Check calibration with M22520/3 gages. Length is 6.75 inches, weight is approx. 10 oz.

Standard **809-015** (M22520/2-01) crimper. Use with standard size #23 and #20HD Mighty Mouse contacts and with M39029/76 and /78 coaxial center contacts. Requires positioner, ordered separately.

Special **809-128** (MH992) crimper used with 50 Ohm matched impedance coaxial inner contacts. Requires positioner, ordered separately.



809-128

Part Number	Military Part Number	Daniels Part Number
809-015	M22520/2-01	AFM8
809-128	(none)	MH992

POSITIONERS FOR USE WITH MINIATURE ADJUSTABLE CRIMP TOOLS



Positioner for use with miniature adjustable crimp tools.

809-005 Positioner for standard size #23 contacts. #22-#28 AWG. For use with M22520/2-01 crimp tool.

809-057 Positioner for small bore size #23

These bayonet-type positioners hold contacts at correct height for crimping with M22520/2 type miniature step adjustable tools, above. Face plate shows correct tool settings.

contacts. #26-#30 AWG. For use with M22520/2-01 crimp tool.

809-124 Positioner for matched impedance #12 coaxial inner contact. For use with 809-128 (MH992) crimp tool.

809-125 (M22520/2-35) Positioner for M39029/76 and 78 coaxial inner contact. For use with M22520/2-01 crimp tool.

809-135 (M22520/2-34) Positioner for #12 coax contacts (M39029/28-211 & 409 and M39029/27-210 & 402). For use with M22520/2-01 crimp tool.

809-174 Positioner for long size #23 pin contact for use with combo arrangements with size #8

contacts. Use with M22520/2-01 crimp tool.

809-206 Positioner for #20HD contacts. Use with M22520/2-01 crimp tool.

809-301 Positioner for large bore size #23 contacts. #20-#22 AWG. Use with M22520/2-01 crimp tool.

809-369 (M22520/2-07) Positioner for long, size #23 socket contacts for use with Mighty Mouse combo arrangements with size #8 contacts. Use with M22520/2-01 crimp tool.

859-006 Positioner for matched impedance #12 coaxial inner contact. Use with 809-128 (MH992) crimp tool.

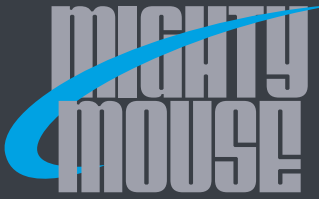

SERIES 80

Mighty Mouse Connectors



Crimp Tools and Positioners for Coaxial Contacts

CRIMP TOOL AND POSITIONER FOR SIZE #12, #16, #20 POWER CONTACTS AND ADAPTERS



809-136

809-136 Crimp tool for use with size #20, #16 and #12 power pins. 9.75 inches OAL, 1.25 pounds. Use with M39029/57 and /58 contacts and 809-093 adapters.

809-138 Positioner for use with 809-093 adapters.

809-137 Positioner for use with size #20, #12 and #16 Power contacts.

Part Number	Military Part Number	Daniels Part Number
809-136	M22520/1-01	AF8
809-137	M22520/1-04	TH163
809-138	(none)	TH653

CRIMP TOOL AND POSITIONER FOR #16 COAXIAL OUTER CONTACT



809-127

For crimping size #16 shield sleeves. These mil spec approved tools feature a ratchet mechanism to prevent damage from overcrimping. Check calibration with M22520/3 gage.

809-127 Crimp tool for use with size #16 coaxial contacts. Blue handles. 9.75 inches OAL, 1.25 pounds.

809-126 Positioner for use with size #16 coaxial contacts. Use with 809-127 (M22520/4-01) crimp tool.

Part Number	Military Part Number	Daniels Part Number
809-127	M22520/4-01	GS100-1
809-126	M22520/4-02	GP295

CRIMP TOOL AND POSITIONER FOR #12 COAXIAL OUTER CONTACT



809-133

For crimping size #12 shield sleeves. These mil spec approved tools feature a ratchet mechanism to prevent damage from overcrimping. Check calibration with M22520/3 gage.

809-133 Crimp tool for use with size #12 coaxial contacts. Black handles. 9.75 inches OAL, 1.25 pounds.

809-134 Positioner for use with size #12 coaxial contacts. Use with 809-133 (M22520/31-01) crimp tool.

Part Number	Military Part Number	Daniels Part Number
809-133	M22520/31-01	GS200-1
809-134	M22520/31-02	G2P330

PARALLEL ACTION CRIMP TOOL AND HEX DIE SET FOR 50 OHM MATCHED IMPEDANCE #12 COAX



809-129

809-129 Parallel action tool for use with hex crimp dies. 11 inches OAL, 2.0 pounds. Anodized aluminum frame, steel mechanism, plastic handles. Includes tool for die set removal. Accepts all M22520/5 die sets.

809-130 Hex die for 852-015 and 852-016 contacts

859-047 Hex die for 853-014, 853-013, 853-017, 853-025, and 853-024 contacts

859-048 Hex die for 853-003, 853-004, 859-042, 854-001, and 854-002

859-051 Hex die for 852-043, 852-042, 852-007, 852-006,

Part Number	Military Part Number	Daniels Part Number
809-129	M22520/5-01	HX4
809-130	M22520/5-03	Y196
859-047	M22520/5-45	
859-048	M22520/5-105	
859-051	M22520/5-05	

CONTACTS AND TOOLS

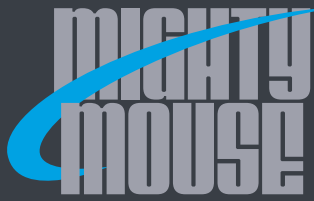

SERIES 80 Mighty Mouse Connectors



Crimp Tools and Positioners for Quadrax, Twinax, Coax or Power Contacts

PNEUMATIC CRIMP TOOL FOR #8 POWER CONTACTS

The Daniels WA23 pneumatic crimp tool sets the standard for heavy duty crimping chores. This four-indent tool accommodates large power contacts ranging from size 8 through size 0000. Die plates and locators are purchased separately. Qualified to M22520/23, the WA23 tool is specified for use with SAE AS39029 closed barrel copper alloy contacts.

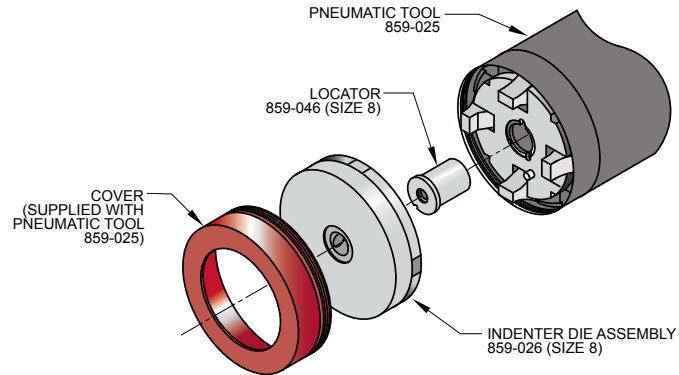

PNEUMATIC CRIMP TOOL



Bench mount heavy duty pneumatic indent crimp tool. Four-indent crimp termination. Use with closed barrel contact sizes 8 through 4/0. Attach to air supply with quick-disconnect fitting or install 1/4 NPT fitting into tapped port. 90-120 psi air supply. Requires die assembly and locator, sold separately. Hand actuate with push-button valve trigger on handle. Steel with black wrinkle enamel coating. 13 inches overall length, 9.2 inches tall, 17 pounds (7.7 Kg).

Description	Part Number	Military Part Number	Daniels Part Number
Pneumatic Crimper	859-025	M22520/23-01	WA23

DIE ASSEMBLY FOR SIZE #8 CONTACTS



Indenter Die Assembly. Precision four-indent die with hardened tool steel indenters, stainless steel housing, aluminum cap. Use with size #8 contacts. Go/ No Go calibration dimensions are stamped on face of tool. Approximately 3.3 inches (84mm.) diameter.

Description	Part Number	Military Part Number	Daniels Part Number
Die Assembly, Size #8	859-026	M22520/23-02	WA23-2

LOCATOR FOR SIZE #8 CONTACTS



Aluminum locator holds contact at correct depth for crimping.

Description	Part Number	Military Part Number	Daniels Part Number
#8, Special	859-046	--	WA23-395L
	859-164	--	--