

V850E2/FG4-L

Hardware

V850E2/FG4-L

μPD70F3576

μPD70F3577

μPD70F3578

μPD70F3579

μPD70F3580

Notice

1. All information included in this document is current as of the date this document is issued. Such information, however, is subject to change without any prior notice. Before purchasing or using any Renesas Electronics products listed herein, please confirm the latest product information with a Renesas Electronics sales office. Also, please pay regular and careful attention to additional and different information to be disclosed by Renesas Electronics such as that disclosed through our website.
2. Renesas Electronics does not assume any liability for infringement of patents, copyrights, or other intellectual property rights of third parties by or arising from the use of Renesas Electronics products or technical information described in this document. No license, express, implied or otherwise, is granted hereby under any patents, copyrights or other intellectual property rights of Renesas Electronics or others.
3. You should not alter, modify, copy, or otherwise misappropriate any Renesas Electronics product, whether in whole or in part.
4. Descriptions of circuits, software and other related information in this document are provided only to illustrate the operation of semiconductor products and application examples. You are fully responsible for the incorporation of these circuits, software, and information in the design of your equipment. Renesas Electronics assumes no responsibility for any losses incurred by you or third parties arising from the use of these circuits, software, or information.
5. When exporting the products or technology described in this document, you should comply with the applicable export control laws and regulations and follow the procedures required by such laws and regulations. You should not use Renesas Electronics products or the technology described in this document for any purpose relating to military applications or use by the military, including but not limited to the development of weapons of mass destruction. Renesas Electronics products and technology may not be used for or incorporated into any products or systems whose manufacture, use, or sale is prohibited under any applicable domestic or foreign laws or regulations.
6. Renesas Electronics has used reasonable care in preparing the information included in this document, but Renesas Electronics does not warrant that such information is error free. Renesas Electronics assumes no liability whatsoever for any damages incurred by you resulting from errors in or omissions from the information included herein.
7. Renesas Electronics products are classified according to the following three quality grades: "Standard", "High Quality", and "Specific". The recommended applications for each Renesas Electronics product depends on the product's quality grade, as indicated below. You must check the quality grade of each Renesas Electronics product before using it in a particular application. You may not use any Renesas Electronics product for any application categorized as "Specific" without the prior written consent of Renesas Electronics. Further, you may not use any Renesas Electronics product for any application for which it is not intended without the prior written consent of Renesas Electronics. Renesas Electronics shall not be in any way liable for any damages or losses incurred by you or third parties arising from the use of any Renesas Electronics product for an application categorized as "Specific" or for which the product is not intended where you have failed to obtain the prior written consent of Renesas Electronics.

The quality grade of each Renesas Electronics product is “Standard” unless otherwise expressly specified in a Renesas Electronics data sheets or data books, etc.

- “Standard”:
- Computers; office equipment; communications equipment; test and measurement equipment; audio and visual equipment; home electronic appliances; machine tools; personal electronic equipment; and industrial robots.
- “High Quality”:
- Transportation equipment (automobiles, trains, ships, etc.); traffic control systems; anti-disaster systems; anti-crime systems; safety equipment; and medical equipment not specifically designed for life support.
- “Specific”:
- Aircraft; aerospace equipment; submersible repeaters; nuclear reactor control systems; medical equipment or systems for life support (e.g. artificial life support devices or systems), surgical implantations, or healthcare intervention (e.g. excision, etc.), and any other applications or purposes that pose a direct threat to human life.

8. You should use the Renesas Electronics products described in this document within the range specified by Renesas Electronics, especially with respect to the maximum rating, operating supply voltage range, movement power voltage range, heat radiation characteristics, installation and other product characteristics. Renesas Electronics shall have no liability for malfunctions or damages arising out of the use of Renesas Electronics products beyond such specified ranges.
9. Although Renesas Electronics endeavors to improve the quality and reliability of its products, semiconductor products have specific characteristics such as the occurrence of failure at a certain rate and malfunctions under certain use conditions. Further, Renesas Electronics products are not subject to radiation resistance design. Please be sure to implement safety measures to guard them against the possibility of physical injury, and injury or damage caused by fire in the event of the failure of a Renesas Electronics product, such as safety design for hardware and software including but not limited to redundancy, fire control and malfunction prevention, appropriate treatment for aging degradation or any other appropriate measures. Because the evaluation of microcomputer software alone is very difficult, please evaluate the safety of the final products or system manufactured by you.
10. Please contact a Renesas Electronics sales office for details as to environmental matters such as the environmental compatibility of each Renesas Electronics product. Please use Renesas Electronics products in compliance with all applicable laws and regulations that regulate the inclusion or use of controlled substances, including without limitation, the EU RoHS Directive. Renesas Electronics assumes no liability for damages or losses occurring as a result of your noncompliance with applicable laws and regulations.
11. This document may not be reproduced or duplicated, in any form, in whole or in part, without prior written consent of Renesas Electronics.

-
12. This document may not be reproduced or duplicated, in any form, in whole or in part, without prior written consent of Renesas Electronics.
 13. Please contact a Renesas Electronics sales office if you have any questions regarding the information contained in this document or Renesas Electronics products, or if you have any other inquiries.

- Notes**
1. "Renesas Electronics" as used in this document means Renesas Electronics Corporation and also includes its majority-owned subsidiaries.
 2. "Renesas Electronics product(s)" means any product developed or manufactured by or for Renesas Electronics.

Regional Information

Some information contained in this document may vary from country to country. Before using any Renesas Electronics product in your application, please contact the Renesas Electronics office in your country to obtain a list of authorized representatives and distributors. They will verify:

- Device availability
- Ordering information
- Product release schedule
- Availability of related technical literature
- Development environment specifications (for example, specifications for third-party tools and components, host computers, power plugs, AC supply voltages, and so forth)
- Network requirements

In addition, trademarks, registered trademarks, export restrictions, and other legal issues may also vary from country to country.

Visit

<http://www.renesas.com>

to get in contact with your regional representatives and distributors.

Notes for CMOS Devices

(1) Precaution against ESD for semiconductors

Strong electric field, when exposed to a MOS device, can cause destruction of the gate oxide and ultimately degrade the device operation. Steps must be taken to stop generation of static electricity as much as possible, and quickly dissipate it once, when it has occurred. Environmental control must be adequate. When it is dry, humidifier should be used. It is recommended to avoid using insulators that easily build static electricity. Semiconductor devices must be stored and transported in an anti-static container, static shielding bag or conductive material. All test and measurement tools including work bench and floor should be grounded. The operator should be grounded using wrist strap. Semiconductor devices must not be touched with bare hands. Similar precautions need to be taken for PW boards with semiconductor devices on it.

(2) Handling of unused input pins for CMOS

No connection for CMOS device inputs can be cause of malfunction. If no connection is provided to the input pins, it is possible that an internal input level may be generated due to noise, etc., hence causing malfunction. CMOS devices behave differently than Bipolar or NMOS devices. Input levels of CMOS devices must be fixed high or low by using a pull-up or pull-down circuitry. Each unused pin should be connected to VDD or GND with a resistor, if it is considered to have a possibility of being an output pin. All handling related to the unused pins must be judged device by device and related specifications governing the devices.

(3) Status before initialization of MOS devices

Power-on does not necessarily define initial status of MOS device. Production process of MOS does not define the initial operation status of the device. Immediately after the power source is turned ON, the devices with reset function have not yet been initialized. Hence, power-on does not guarantee out-pin levels, I/O settings or contents of registers. Device is not initialized until the reset signal is received. Reset operation must be executed immediately after power-on for devices having reset function.

Table of contents

Chapter 1	Overview	9
1.1	Naming	9
1.1.1	Alternative function pins	9
1.1.2	Power supply pins	9
1.2	Pin Groups	10
1.3	General measurement conditions	10
1.3.1	AC characteristic measurement condition	10
Chapter 2	Absolute maximum ratings	11
2.1	Supply voltages	11
2.2	Port voltages	11
2.3	Port current	12
2.4	Capacitance	13
2.5	Thermal characteristics	13
Chapter 3	Power supply specification	14
3.1	Requirements for external power supply connections	14
3.2	Power area definitions	14
3.3	Power supply groups	15
3.4	Supply voltages	16
3.4.1	AWO Regulator characteristics	17
3.4.2	ISO Regulator characteristics	18
3.4.3	POC characteristics	19
3.5	Power-up/-down sequence of external supply voltages	20
3.5.1	External FLMDn Resistors	20
3.5.2	Condition 1	20
3.5.3	Condition 2	21
3.5.4	Condition 3	22
Chapter 4	Clock generators	23
4.1	CPU clock	23
4.2	Peripheral clock	23
4.3	Oscillator characteristics	24
4.3.1	Main oscillator	24
4.3.2	Internal oscillator	25
4.4	PLL Characteristics	25
Chapter 5	I/O specification	26
5.1	Port Characteristics	26
5.1.1	Condition settings	26
5.1.2	PgE0	28
5.1.3	PgE1	29
5.1.4	PgA0	30
Chapter 6	Supply current specification	31

Chapter 7	Peripherals specification	32
7.1	Reset timing.....	32
7.2	NMI timing.....	32
7.3	INTP timing.....	33
7.4	FLMD0 timing.....	33
7.5	_DCUTRST timing.....	33
7.6	Timer timing.....	34
7.7	CSI timing.....	35
	7.7.1 Master modes.....	35
	7.7.2 Slave mode.....	38
7.8	UART timing.....	41
7.9	FCN timing.....	42
7.10	IIC timing.....	43
7.11	VLVI characteristics.....	45
7.12	LVI characteristics.....	46
7.13	A/D Converter characteristics.....	47
	7.13.1 10bit A/D.....	47
	7.13.2 Equivalent circuit.....	48
	7.13.3 ADTRG timing.....	48
7.14	Key Return.....	49
7.15	DPIN (SEQ Digital Input).....	49
Chapter 8	Memory specification	50
8.1	Code flash specification.....	50
8.2	Data flash specification.....	50
8.3	Serial write operation specification.....	50
Chapter 9	Pinning and package specification	51
9.1	Pinning specification.....	51
9.2	Package specification.....	52

Chapter 1 Overview

1.1 Naming

1.1.1 Alternative function pins

Peripheral	Prefix	Function name	Suffix
Short-cut of macro name	Consecutive number for same peripheral module ^a	Peripheral Macro pin naming	Consecutive number for same pin names ^a

^{a)} This is an option that can be omitted if meaning is obvious

Example:

- CSIG0SO, CSIG0SI, CSIG0SC, CSIG0RYI, CSIG0RYO

1.1.2 Power supply pins

Function	Prefix	Kind of supply	Suffix
Symbol	Consecutive number for different functions ^a	VDD or VSS	Consecutive number for different pins with same meaning ^a

^{a)} This is an option that can be omitted if meaning is obvious

Example:

- E0VDDn, REG0VSS

Table 1-1 Selection for Functions

Function	Explanation
REG	Internal regulator supply
OSC	Oscillator supply
I0	Flash module supply and ISO0 Internal regulator supply (mainly 5V)
E	Standard buffer supply (mainly 5V or up to 20Mhz)
A	Analog module supply (e.g. ADC)

If not mentioned otherwise this document neglects suffixes for power supply pins with same functions that can be treated as equal.

1.2 Pin Groups

Symbol	Pin group supplied by	Related pins / ports
PgE0	E0VDD / E0VSS	JP0, P0, _RESET, FLMD0,
PgE1	E1VDD / E1VSS	P1, P3, P4
PgOSC	OSCVDD / OSCVSS	X1, X2
PgA0	A0VREFP / A0VSS	P10, P11

1.3 General measurement conditions

1.3.1 AC characteristic measurement condition

AC test input waveform

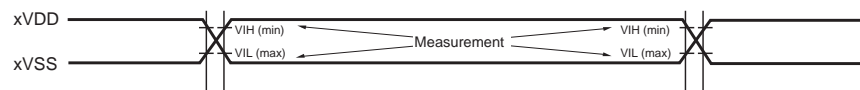

AC test output waveform

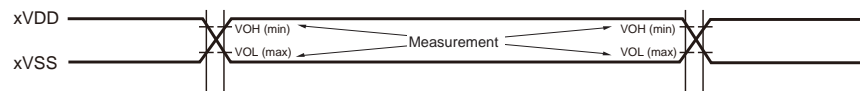

Standard AC test condition is 70%/30% of the applied IO supply voltage (X_mVDD) if not otherwise stated in the according AC timing specification of an interface.

AC Test Condition: Ext. Capacitive Load

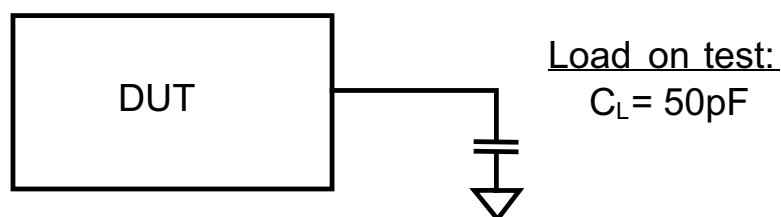

Chapter 2 Absolute maximum ratings

2.1 Supply voltages

Table 2-1 VDD Data

Parameter	Symbol	Condition	Ratings	Unit
System	CVDD		-0.3 ~ 1.6	V
	I0VDD		-0.3 ~ 6.0	V
	OSCVDD		-0.3 ~ 6.0	V
	REG0VDD		-0.3 ~ 6.0	V
	REG1VDD		-0.3 ~ 6.0	V
	REG2VDD		-	V
	REG3VDD		-	V
Ports	E0VDD		-0.3 ~ 6.0	V
	E1VDD		-0.3 ~ 6.0	V
ADCA0	A0VREFP		-0.3 ~ 6.0	V

2.2 Port voltages

Table 2-2 Port Input voltage

Parameter	Pin Group ^a	Symbol	Condition	Ratings	Unit
Input voltage ^b	PgE0	V _I	E0VDD ≤ 5.5	-0.3 ~ E0VDD+0.3	V
	PgE1		E1VDD ≤ 5.5	-0.3 ~ E1VDD+0.3	V
	PgOSC		OSCVDD ≤ 5.5	-0.3 ~ OSCVDD+0.3	V
	PgA0			-0.3 ~ A0VREFP+0.3	V

a) The pin groups reflect all supplies within the device series. Therefore not every pin group is available for each product.

b) The characteristics of the alternative-function pins are the same as those of the port pins unless otherwise specified.

2.3 Port current

Table 2-3 High level port output current

Parameter	Pin Group ^a	Symbol	Condition	Max. spec	Unit
High level output current	PgE0/PgE1	I_{OH}	1 pin of PgE0/PgE1	-10	mA
			Power supply of PgE0 and PgE1	-120 ^b	mA
	PgA0		1 pin of PgA0	-10	mA
			Power supply of PgA0	-25	mA

a) The column reflects all supplies within the device series. Therefore not each pin group is available for each product.

b) Do not exceed -30 mA on a side.

Table 2-4 Low level port output current

Parameter	Pin Group ^a	Symbol	Condition	Max. spec	Unit
Low level output current	PgE0/PgE1	I_{OL}	1 pin of PgE0/PgE1	10	mA
			Power supply of PgE0 and PgE1	120 ^b	mA
	PgA0		1 pin of PgA0	10	mA
			Power supply of PgA0	25	mA

a) The column reflects all supplies within the device series. Therefore not each pin group is available for each product.

b) Do not exceed -30 mA on a side.

2.4 Capacitance

Parameter	Symbol	Condition	Max. spec	Unit
Input capacitance	C_I	f = 1 MHz 0V for non measurement pins	15	pF
Input/Output capacitance	C_{IO}		15	pF
Output capacitance	C_O		15	pF

2.5 Thermal characteristics

Table 2-5 Thermal characteristics

Parameter	Symbol	Condition	Ratings	Unit
Storage temperature	T_{STG}		-55 ~125	°C
Operating ambient temperature	T_a	(A) grade products	-40 ~85	
		(A1) grade products	-40 ~110	
		(A2) grade products	-40 ~125	

This section specifies the absolute maximum limitation of operating and storage temperature.

The device's functions are not guaranteed outside of the specified maximum temperature ratings.

Chapter 3 Power supply specification

3.1 Requirements for external power supply connections

The user has to ensure a low resistive connection of all VSS pins on the PCB. This specification denotes ground supply pins as:

- VSS = OSCVSS = REGnVSS = EnVSS = A0VSS = 0V

in the further text.

With

- EnVSS = E0VSS = E1VSS
- REGnVSS = REG0VSS = REG1VSS

The user has to ensure a low resistive connection of all VDD pins to the related power supply. This specification denotes power supply pins as:

- EnVDD, I/OVDD, REGnVDD, OSCVDD, A0VREFP.

in the further text.

With

- EnVDD = E0VDD = E1VDD
- REGnVDD = REG0VDD = REG1VDD.
- I/OVDD = A0VREFP, EnVDD, IOVDD, OSCVDD

3.2 Power area definitions

The device consists of the following power areas:

- AWO (Always On area)
- ISO0 (Isolated area 0)

The table below lists the related core and port voltage supply of each power area:

Table 3-1 Power areas supply voltages

Power Area	Supply voltage	Related pins
AWO	Internal regulator supply	REG0VDD, REG0VSS
	Port Supply	E0VDD, E0VSS
	Other	OSCVDD, OSCVSS IOVDD
ISO0	Internal regulator supply	REG1VDD, REG1VSS
	Port Supply	E1VDD, E1VSS
	Other	A0VREFP, A0VSS

3.3 Power supply groups

For each of the following power supply groups the same voltage must be supplied:

Table 3-2 Power supply groups

Power supply group	Related pins
#1	REG0VDD, REG1VDD, I0VDD, OSCVDD, E0VDD, E1VDD
#3	-
#5	A0VREFP
#7	All VSS

3.4 Supply voltages

Table 3-3 VDD Data

Parameter	Symbol	Condition	Ratings			Unit
			Min	Typ	Max	
System supply voltage	I0VDD		VPOC		5.5	V
System supply voltage	OSCVDD		VPOC		5.5	V
System supply voltage	REG0VDD	REG0VDD = REG1VDD	VPOC		5.5	V
System supply voltage	REG1VDD		VPOC		5.5	V
System supply voltage	REG2VDD		-		-	V
System supply voltage	REG3VDD		-		-	V
Port supply voltages	E0VDD		VPOC		5.5	V
Port supply voltages	E1VDD		VPOC		5.5	V
ADC supply voltages	A0VREFP		VPOC		5.5	V

3.4.1 AWO Regulator characteristics

Table 3-4 AWO Regulator characteristics

Parameter	Symbol	Condition	Ratings			Unit
			Min	Typ	Max	
Regulator Output voltage	VRO		1.35	1.50	1.65	V
System supply voltage slope	RAVS	0V to VPOC	0.5		150	V/ms
Capacitance on REG0C	REG0C		2.31		6.11	μ F

3.4.2 ISO Regulator characteristics

Table 3-5 ISO regulator characteristics

Parameter	Symbol	Condition	Ratings			Unit
			Min	Typ	Max	
Output voltage	VROI		1.35	1.50	1.65	V
Capacitance on REGnC	REGnC		0.07	0.1	0.13	μF
Voltage slope	RIVS		0.18		1800	V/ms
Response time	tPTHd					a
CPU Start-up time	T_{cpusu}	Time from ISO0 wake-up to 1 st CPU instruction fetch.		600	750	μs

a) see chapter 3.4.3 "POC characteristics"

Note n=1

3.4.3 POC characteristics

Table 3-6 POC characteristics

Parameter	Symbol	Condition	Ratings			Unit
			Min	Typ	Max	
Detection voltage	VPOC		2.75	2.9	3.0	V
Voltage slope 1	PVS1		0.18		1800	V/ms
Voltage slope 2	PVS2		0.0018		1800	V/ms
Response time 1	tPTH1				2	ms
Response time 2	tPD				2	ms
VDD minimum width	tPW		0.2			ms

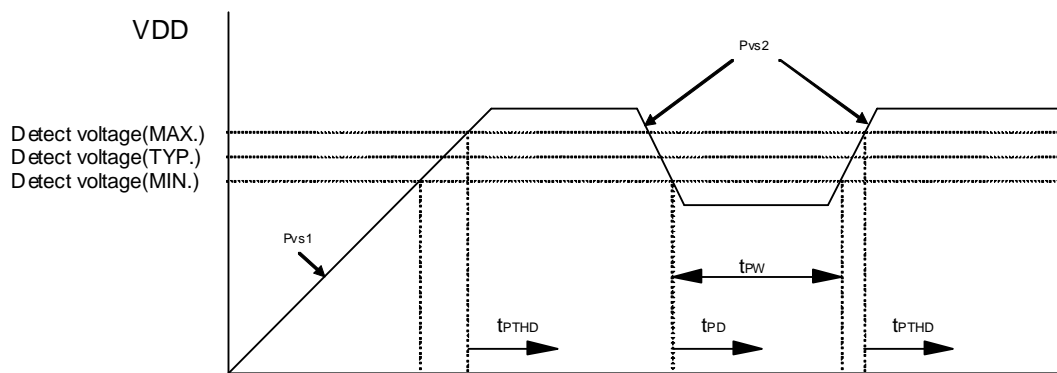

3.5 Power-up/-down sequence of external supply voltages

3.5.1 External FLMDn Resistors

Valid for all conditions described in the following

Parameter	Symbol	Condition	Ratings			Unit
			Min	Typ	Max	
FLMD0 external pull-down resistor	R1		82	-	-	kΩ
FLMD1 external pull-down resistor	R2		-	10	-	kΩ

3.5.2 Condition 1

RESET is not used

Parameter	Symbol	Condition	Ratings			Unit
			Min	Typ	Max	
VDD ^a (rise) to FLMD0,P0_1/FLMD1(≤VIL) hold time	tROMDH		2			ms
FLMD0,P0_1/FLMD1 (≤VIL) to VDD ^a (fall) hold time	tMDR0OF		0			ms

a) VDD:REGnVDD, I0VDD, OSCVDD, EnVDD,A0VREFP

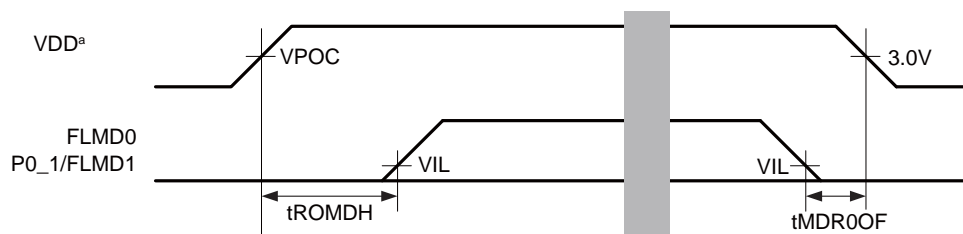

3.5.3 Condition 2

RESET is used

Parameter	Symbol	Condition	Ratings			Unit
			Min	Typ	Max	
VDD ^a (rise) to FLMD0, P0_1/ FLMD1(≤VIL) hold time	tR0MDH		1			ms
VDD ^a (rise) to _RESET (≤VIL) hold time	tR0RR ^b		2			ms
FLMD0, P0_1/FLMD1 (≥VIH) to _RESET (≤VIL) setup time	tMDRRH		1			ms
FLMD0, P0_1/FLMD1 (≤VIL) to _RESET (≤VIL) setup time	tMDRRL		1			ms
_RESET (≥VIH) to FLMD0, P0_1/FLMD1(≥VIH/≤VIL) hold time	tRMDH		1			ms
FLMD0, P0_1/FLMD1(≤VIL) to _RESET (≥VIH) setup time	tMDRF		0			ms
_RESET (≤VIL) to VDD ^a (fall) hold time	tRR0OF		0			

a) VDD: REGnVDD, I0VDD, OSCVDD, EnVDD, A0VREFP

b) When the specification of tR0RR cannot be secured, _RESET flag of RESF register may not set up, and operation is guaranteed.

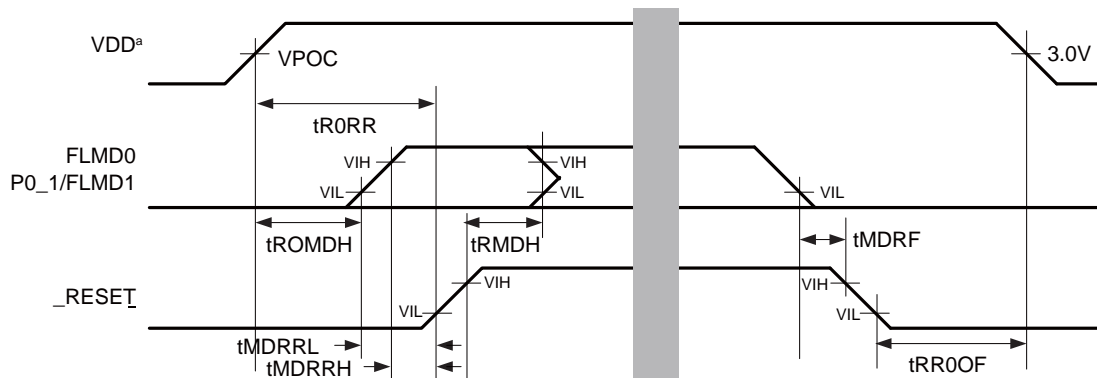

3.5.4 Condition 3

RESET is used.

Normal operating mode / Serial programming mode

Parameter	Symbol	Condition	Ratings			Unit
			Min	Typ	Max	
VDD ^a (rise) to FLMD0 (\leq VIL) hold time	tR0MDH		1			ms
VDD ^a (rise) to _RESET (\leq VIL) hold time	tR0RR ^b		2			ms
_RESET (\geq VIH) to FLMD0 (\geq VIH) hold time	tRMDH		1			ms
FLMD0(\geq VIH) to _RESET (\leq VIL) setup time	tMDRRH		1			ms
CPU start-up time (_RESET (\geq VIH) to internal reset delay time)	tSU				2.5	ms
_RESET (\geq VIH) to FLMD0 pulse input start time	tRP		tSU(max)+0.73			ms
_RESET (\geq VIH) to FLMD0 pulse input end time	tRPE				tSU(max)+10	ms
FLMD0 low/high level width	tPW		0.8			

a) VDD:REGnVDD, I0VDD, OSCVDD, EnVDD,A0VREFP

b) When the specification of tR0RR cannot be secured, _RESET flag of RESF register may not set up, and operation is guaranteed.

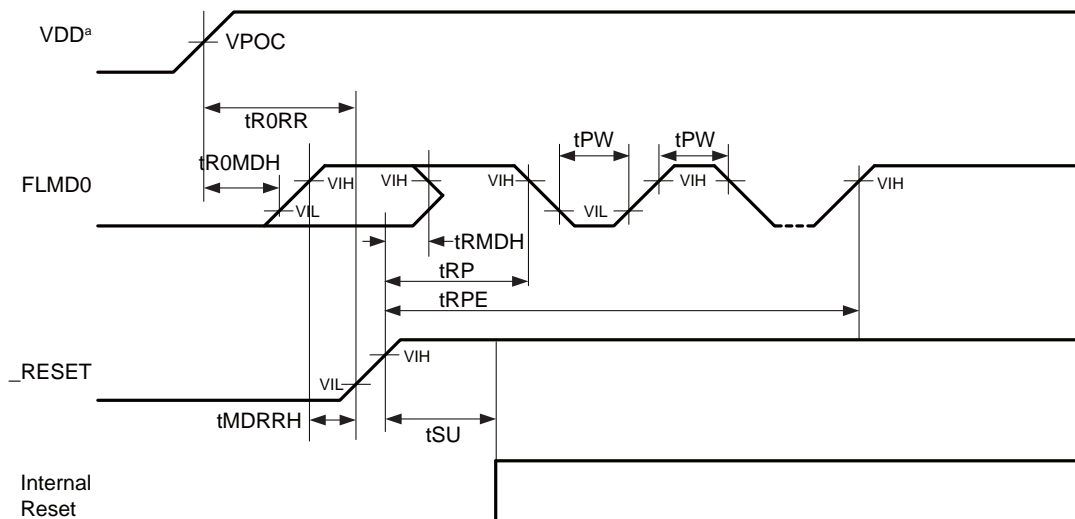

Chapter 4 Clock generators

Refer to the chapter 3.4 “Supply voltages” for supply voltage conditions.

4.1 CPU clock

Table 4-1 CPU clock frequency

Parameter	Symbol	Condition	Ratings			Unit
			Min	Typ	Max	
CPU clock frequency	fCPU	≥768KB CodeFlash			64	MHz
		≤512KB CodeFlash			48	MHz

4.2 Peripheral clock

Table 4-2 Peripheral clock frequency

Parameter	Symbol	Condition	Ratings			Unit
			Min	Typ	Max	
Peripheral clock frequency	fPERI				48 ^a	MHz

a) Some peripherals can be operated at 64MHz. Refer to the chapter ‘Clock Selection’ in the UM for details.

4.3 Oscillator characteristics

4.3.1 Main oscillator

A ceramic or crystal resonator can be connected to the main clock input pins as shown in figure 4-1 "Recommended Main Oscillator Circuit"

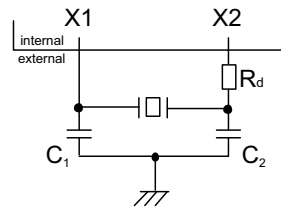

Figure 4-1 Recommended Main Oscillator Circuit

Caution Values of C_1 , C_2 and R_d depend on the used ceramic or crystal resonator and must be specified in cooperation with ceramic or crystal resonator manufacturer.

(1) Main oscillator characteristics

Table 4-3 Main oscillator characteristics

Parameter	Symbol	Condition	Ratings	Unit
MainOSC frequency	fMOSC	Maximum variation $\pm 0.5\%$	4, 5, 6, 8, 10, 12, 16, 20	MHz

- Cautions**
- External clock input is prohibited.
 - General guidance for PCB layout:
 - Keep the wiring length as short as possible.
 - Do not cross the wiring with other signal lines.
 - Do not route this circuit close to a signal line with high fluctuating current flow.
 - Always make the ground point of the oscillator capacitor the same potential as REG0VSS and OSCVSS.
 - Do not ground the capacitor to a ground pattern with high current flow.
 - Do not tap signals from the oscillator.

4.3.2 Internal oscillator

Table 4-4 Internal oscillator characteristics

Parameter	Symbol	Condition	Ratings			Unit
			Min	Typ	Max	
Lowspeed OSC frequency	fRL	<ul style="list-style-type: none"> Other than DeepStop mode DeepStop mode with PSC0.PSC0REGSTP = 0 	220.8	240	259.2	kHz
	fRLLP	<ul style="list-style-type: none"> DeepStop mode with PSC0.PSC0REGSTP = 1 	172.0	240	268.0	kHz
Highspeed OSC frequency	fRH	<ul style="list-style-type: none"> Other than DeepStop mode DeepStop mode with PSC0.PSC0REGSTP = 0 	7.2	8.0	8.8	MHz
		<ul style="list-style-type: none"> Other than DeepStop mode DeepStop mode with PSC0.PSC0REGSTP = 0 ACT13M=1 	8.558		17.41	MHz
	fRHLP	<ul style="list-style-type: none"> DeepStop mode with PSC0.PSC0REGSTP = 1 	5.3	8.0	9.0	MHz
		<ul style="list-style-type: none"> DeepStop mode with PSC0.PSC0REGSTP = 1 ACT13M=1 	2.534		6.385	MHz

4.4 PLL Characteristics

Table 4-5 PLL characteristics

Parameter	Symbol	Condition	Ratings			Unit
			Min	Typ	Max	
Output frequency ^a	fxxn	≥768KB CodeFlash	20		64	MHz
		≤512KB CodeFlash	20		48	MHz
Lock time	TLCKPn				50	μs
Period jitter	TPEJTn				160	ps
Long term jitter	TLTJTn				2500	ps

a) The PLL output frequency is not included the crossing of MainOSC and the Period jitter and the Long term jitter of PLL.

Chapter 5 I/O specification

Refer to the chapter 3.4 “Supply voltages” for supply voltage conditions.

5.1 Port Characteristics

5.1.1 Condition settings

Some of the conditions mentioned in this chapter can be selected by software. The related register settings are described below:

(1) Input characteristic

The input characteristics can be selected by the registers PIS and PISE with the following coding:

Table 5-1 Input characteristic selection for JP0_1, JP0_5, P0, P1, P3, P4

PISE	PIS	Reference in UserManual	Electrical characteristic
1	0	Type 3	Schmitt1
1	1	Type 4	Schmitt4 ^a
0	x	Setting prohibited	

a) Default value after reset

Table 5-2 Input characteristic selection JP0_0, JP0_2, JP0_3

PISE	PIS	Reference in UserManual	Characteristic
0	1	Type 2	Schmitt2
1	1	Type 4	Schmitt4 ^a
other than the above		Setting prohibited	

a) Default value after reset

Table 5-3 Input characteristic selection JP0_4

PISE	PIS	Reference in UserManual	Characteristic
1	1	Type 4	Schmitt4 ^a
other than the above		Setting prohibited	

a) Default value after reset

Table 5-4 Input characteristic RESET Pin

PISE	PIS	Reference in UserManual	Characteristic
-	-	Type 2	Schmitt2 ^a

a) Default value after reset (fixed)

5.1.2 PgE0

Table 5-5 PgE0 characteristics

Parameter	Symbol	Condition	Ratings			Unit
			Min	Typ	Max	
High level input voltage	VIH	-	-		-	V
		Schmitt1	0.7·E0VDD		E0VDD+0.3	
		Schmitt2	0.8·E0VDD		E0VDD+0.3	
		Schmitt4 (E0VDD=VPOC~3.0)	0.84·E0VDD		E0VDD+0.3	
		Schmitt4 (E0VDD=3.0~5.5)	0.8·E0VDD		E0VDD+0.3	
Low level input voltage	VIL	-	-		-	V
		Schmitt1	-0.3		0.3·E0VDD	
		Schmitt2	-0.3		0.2·E0VDD	
		Schmitt4 (E0VDD=VPOC~3.4)	-0.3		0.4·E0VDD	
		Schmitt4 (E0VDD=3.4~5.5)	-0.3		0.5·E0VDD	
High level output voltage	VOH	IOH ^a = -3mA	E0VDD-1.0			V
		IOH = -100μA	E0VDD-0.5			
Low level output voltage	VOL	IOL ^a = 3mA			0.4	V
		IOL = 100μA			0.4	
Input hysteresis of Schmit	VH	Schmitt1	0.3			V
		Schmitt2	0.3			
		Schmitt4	0.1			
Internal pull-up resistor	RU		15	40	150	kΩ
Internal pull-down resistor	RD		15	40	150	kΩ
High level port output current	IOH	Power supply of PgE0 + PgE1			-120 ^b	mA
Low level port output current	IOL	Power supply of PgE0 + PgE1			120 ^b	mA
High level input leakage current	ILIH	VI = E0VDD			0.5	μA
Low level input leakage current	ILIL	VI = 0V			-0.5	μA
High level output leakage current	ILOH	VO = E0VDD			0.5	μA
Low level output leakage current	ILOL	VO = 0V			-0.5	μA
Output frequency	fO				20	MHz
Rise time (output)	tKRP				15	ns
Fall time (output)	tKFP				15	ns

a) Refer to 2.3 "Port current".

b) Do not exceed 30mA per each side of microcontroller.

5.1.3 PgE1

Table 5-6 PgE1 characteristics

Parameter	Symbol	Condition	Ratings			Unit
			Min	Typ	Max	
High level input voltage	VIH	-	-		-	V
		Schmitt1	0.7·E1VDD		E1VDD+0.3	
		-	-		-	
		Schmitt4 (E1VDD=VPOC~3.0)	0.84·E1VDD		E1VDD+0.3	
		Schmitt4 (E1VDD=3.0~5.5)	0.8·E1VDD		E1VDD+0.3	
Low level input voltage	VIL	-	-		-	V
		Schmitt1	-0.3		0.3·E1VDD	
		-	-		-	
		Schmitt4 (E1VDD=VPOC~3.4)	-0.3		0.4·E1VDD	
		Schmitt4 (E1VDD=3.4~5.5)	-0.3		0.5·E1VDD	
High level output voltage	VOH	IOH ^a = -3mA	E1VDD-1.0			V
		IOH = -100μA	E1VDD-0.5			
Low level output voltage	VOL	IOL ^a = 3mA			0.4	V
		IOL = 100μA			0.4	
Input hysteresis of Schmit	VH	Schmitt1	0.3			V
		-	-		-	
		Schmitt4	0.1			
Internal pull-up resistor	RU		15	40	150	kΩ
Internal pull-down resistor	RD		15	40	150	kΩ
High level port output current	IOH	Power supply of PgE0 + PgE1			-120 ^b	mA
Low level port output current	IOL	Power supply of PgE0 + PgE1			120 ^b	mA
High level input leakage current	ILIH	VI = E1VDD			0.5	μA
Low level input leakage current	ILIL	VI = 0V			-0.5	μA
High level output leakage current	ILOH	VO = E1VDD			0.5	μA
Low level output leakage current	ILOL	VO = 0V			-0.5	μA
Output frequency	FO				20	MHz
Rise time (output)	tKRP				15	ns
Fall time (output)	tKFP				15	ns

a) Refer to 2.3 "Port current".

b) Do not exceed 30mA per each side of microcontroller.

5.1.4 PgA0

Table 5-7 PgA0 characteristics

Parameter	Symbol	Condition	Ratings			Unit
			Min	Typ	Max	
High level input voltage	VIH	CMOS1	0.7·A0VREFP		A0VREFP+0.3	V
Low level input voltage	VIL	CMOS1	-0.3		0.3·A0VREFP	V
High level output voltage	VOH	IOH ^a = -1mA	A0VREFP-1.0			V
		IOH = -100μA	A0VREFP-0.5			
Low level output voltage	VOL	IOL ^a = 1mA			0.4	V
		IOL = 100μA			0.4	
High level port output current	IOH	Power supply of PgA0			-25	mA
Low level port output current	IOL	Power supply of PgA0			25	mA
High level input leakage current	ILIH	VI = A0VREFP			0.5	μA
Low level input leakage current	ILIL	VI = 0V			-0.5	μA
High level output leakage current	ILOH	VO = A0VREFP			0.5	μA
Low level output leakage current	ILOL	VO = 0V			-0.5	μA
Output frequency	fO				20	MHz
Rise time (output)	tKRP				15.5	ns
Fall time (output)	tKFP				15.5	ns

a) Do not exceed total current -20mA for VOH / 20mA for VOL (PgA0) .

Chapter 6 Supply current specification

Item	Power ^a	Condition ^b						Product	Specification				Unit
	ISO0	Main OSC	High-speed IntOsc	Low-speed IntOsc	PLL	CPU Freq [MHz]	Peripherals		TYP.	MAX. (A)	MAX. (A1)	Max. (A2)	
RUN mode	ON	ON	ON	ON	ON	64	WORKING at 32MHz	μPD70F3580 μPD70F3579	18	30	33	36	mA
	ON	ON	ON	ON	ON	48	WORKING at 48MHz	μPD70F3580 μPD70F3579	18	30	33	36	mA
	ON	ON	ON	ON	ON	48	WORKING at 48MHz	μPD70F3578 μPD70F3577 μPD70F3576	17	28	31	34	mA
	ON	OFF	ON	ON	OFF	8	WORKING at 8MHz	μPD70F3580 μPD70F3579	6	18	20	22	mA
	ON	OFF	ON	ON	OFF	8	WORKING at 8MHz	μPD70F3578 μPD70F3577 μPD70F3576	6	16	17	18	mA
RUN mode (EEPROM emulation)	ON	ON	ON	ON	ON	64	WORKING at 32MHz	μPD70F3580 μPD70F3579	35	58	61	64	mA
	ON	ON	ON	ON	ON	48	WORKING at 48MHz	μPD70F3580 μPD70F3579	35	58	61	64	mA
	ON	ON	ON	ON	ON	48	WORKING at 48MHz	μPD70F3578 μPD70F3577 μPD70F3576	34	56	59	62	mA
STOP mode	ON	OFF	OFF	ON	OFF	OFF	STOPPED	μPD70F3580 μPD70F3579 μPD70F3578 μPD70F3577 μPD70F3576	1.3	12	13	16	mA
DEEPSTOP mode (PSC0.PSC0REGSTP=1)	OFF	OFF	OFF	ON	OFF	OFF	STOPPED	μPD70F3580 μPD70F3579 μPD70F3578 μPD70F3577 μPD70F3576	0.025	0.220	0.250	0.300	mA
DEEPSTOP mode (PSC0.PSC0REGSTP=0)	OFF	OFF	OFF	ON	OFF	OFF	STOPPED	μPD70F3580 μPD70F3579 μPD70F3578 μPD70F3577 μPD70F3576	0.075	0.660	0.750	0.900	mA

a) The AWO is always ON.

b) The 240kHz IntOSC is always ON.

- Notes**
1. The above currents do not include port buffer currents.
 2. The currents in run mode include currents for self-programming.
 3. The 'typical' specification is for reference only and not a guaranteed value. The 'typical' specification is applicable under the following conditions:
 - Ta = 25°C
 - REGnVDD=I0VDD=OSCVDD=EmVDD=A0VREFP=5.0V
 - REGnVSS=OSCVSS=EmVSS=A0VSS=0V

Chapter 7 Peripherals specification

Refer to the chapter 3.4 “Supply voltages” for supply voltage conditions.

7.1 Reset timing

Parameter	Symbol	Condition	Ratings			Unit
			Min	Typ	Max	
RESET input Low level width	tWRSL	Except power on	450	-	-	ns

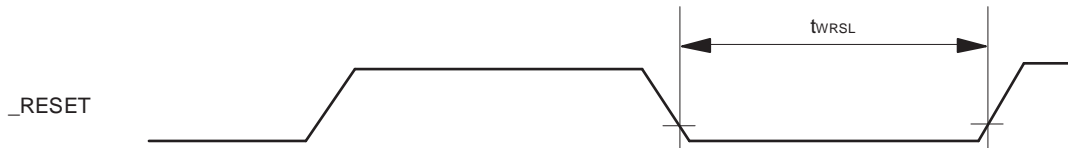

7.2 NMI timing

Parameter	Symbol	Condition	Ratings			Unit
			Min	Typ	Max	
NMI input High level width	tWNIH		300	-	-	ns
NMI input Low level width	tWNIL		300	-	-	ns

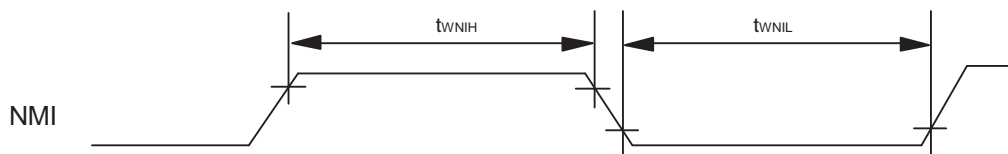

7.3 INTP timing

Parameter	Symbol	Condition	Ratings			Unit
			Min	Typ	Max	
INTPn input High level width	tW _{ITH}		300	-	-	ns
INTPn input Low level width	tW _{ITL}		300	-	-	ns

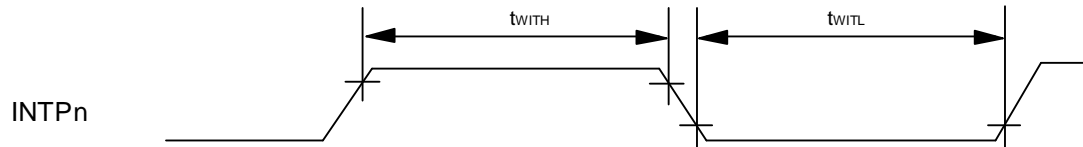

7.4 FLMD0 timing

Parameter	Symbol	Condition	Ratings			Unit
			Min	Typ	Max	
FLMD0 input High level width	tW _{MDH}		300	-	-	ns
FLMD0 input Low level width	tW _{MDL}		300	-	-	ns
FLMD0 external pull down resistor	R _{FLMD0}		82	-	-	kΩ

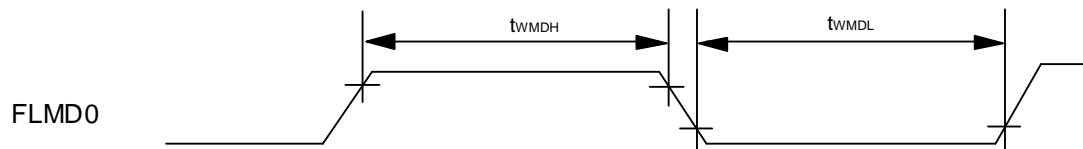

7.5 _DCUTRST timing

Parameter	Symbol	Condition	Ratings			Unit
			Min	Typ	Max	
_DCUTRST input High level width	tW _{TRH}		450	-	-	ns
_DCUTRST input Low level width	tW _{TRL}		450	-	-	ns

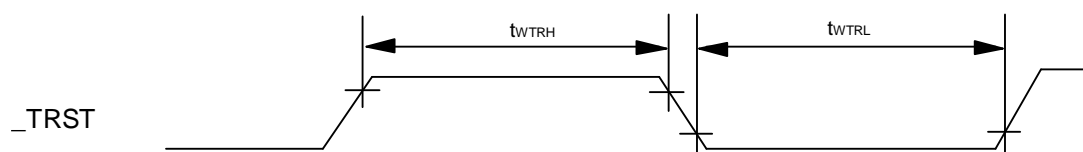

7.6 Timer timing

Table 7-1 Timer timing

Parameter	Symbol	Condition	Ratings			Unit
			Min	Typ	Max	
TAUBnI input High level width	tTBIH	n=0	a, b	-	-	ns
TAUBnI input Low level width	tTBIL	n=0	a, b	-	-	ns
TAUJnI input High level width	tTJIH	n=0	300	-	-	ns
TAUJnI input Low level width	tTJIL	n=0	300	-	-	ns
TAUBnO output cycle	tTBCYK		-	-	20	MHz
TAUJnO output cycle	tTJCYK		-	-	20	MHz

- a) With digital noise filter enabled: $2, 3, 4$ or $5 \times T_{\text{samp}} + 20$ (T_{samp} shows sampling period specified in Noise filter macro. More than 1 PCLK width of Timer macro must be kept regarding DNF pass through pulse width.)
- b) With digital noise filter disabled: $1 \times t_{\text{SYNC}} + 20$ (t_{SYNC} : 1 PCLK of Timer macro)

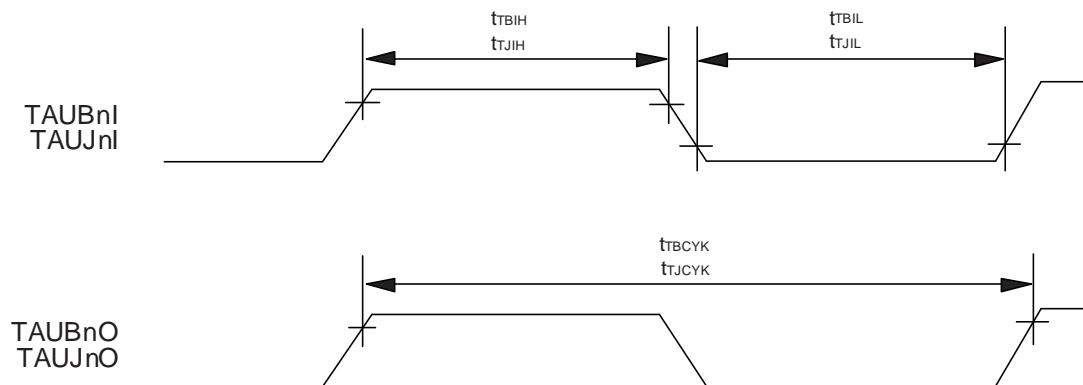

7.7 CSI timing

7.7.1 Master modes

(1) CSIG timing

Table 7-2 CSIG timing (Master mode)

Parameter	Symbol	Condition	Ratings			Unit
			Min	Typ	Max	
Macro Operation clock cycle time	tKCYGn		20.83	-	-	ns
CSIGnSC cycle time	tKCYMGn		100	-	-	ns
CSIGnSC high level width	tKWHMGn		$0.5 \cdot tKCYMGn - 10$	-	-	ns
CSIGnSC low level width	tKWLMGn		$0.5 \cdot tKCYMGn - 10$	-	-	ns
CSIGnSI setup time (vs. CSIGnSC)	tSSIMGn		30	-	-	ns
CSIGnSI hold time (vs. CSIGnSC)	tHSIMGn		0	-	-	ns
CSIGnSO output delay (vs. CSIGnSC)	tDSOMGn		-	-	7	ns
CSIGnRYI setup time (vs. CSIGnSC)	tSRYIGn	CSIGnCTL1.CSIGnSIT=x CSIGnCTL1.CSIGnHSE=1	$2 \cdot tKCYGn + 25$	-	-	ns
CSIGnRYI High level width	tWRYIGn	CSIGnCTL1.CSIGnHSE=1	$tKCYGn - 5.0$	-	-	ns

Note n: Number of macro instances. Refer to the User Manual for the detailed specification.

(2) Timing diagrams

SCKO / SI / SO

CSIG (CSIGnCTL1 : CSIGnCKR/ CSIGnCFG0 :CHIGnDAP0 = 0 / 0 or 1 / 1)

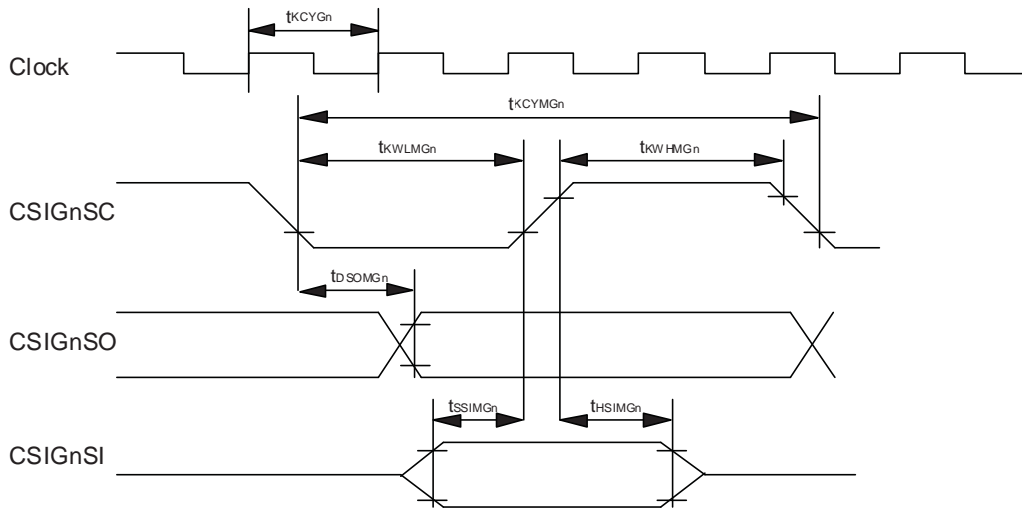

CSIG(CSIGnCTL1 : CSIGnCKR/ CSIGnCFG0 :CHIGnDAP0 = 1 / 0 or 0 / 1)

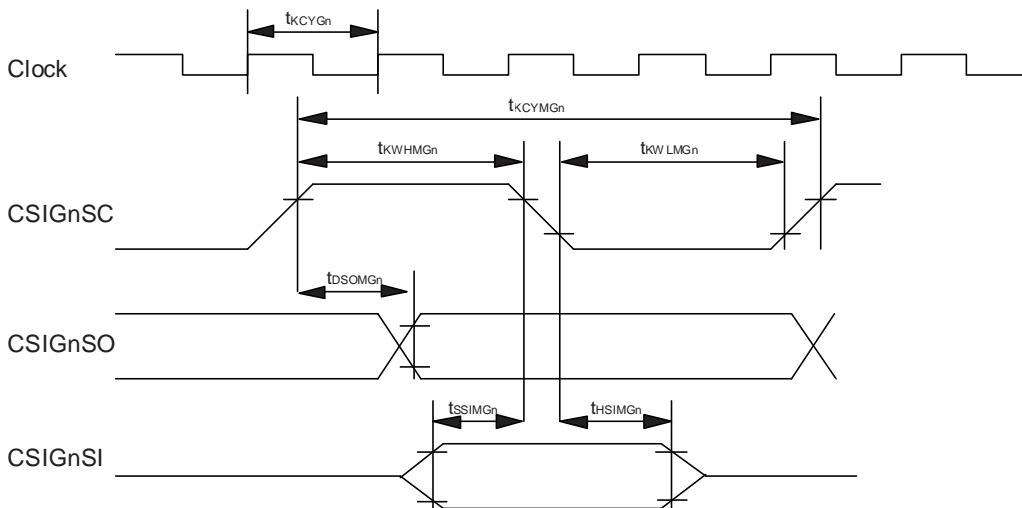

RYI

CSIGnCTL1 : CSIGnHSE=1, CSIGnCTL1 : CSIGnSIT = 0)

CSIG (CSIGnCTL1 :CSIGnCKR= 0)

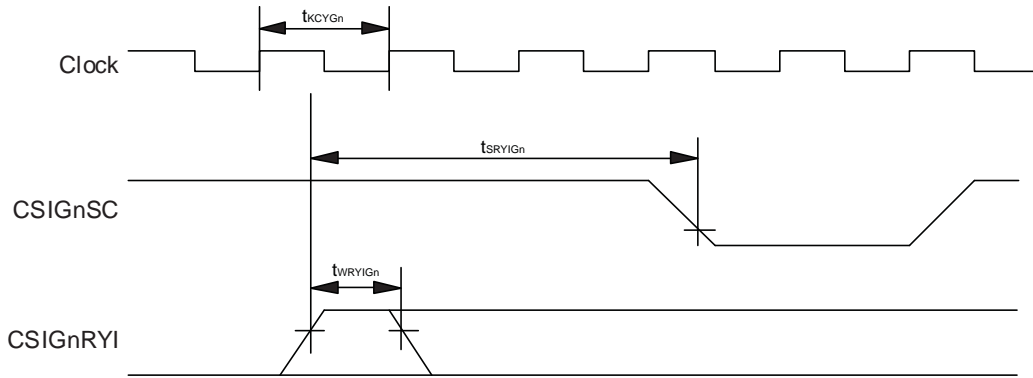

CSIG (CSIGnCTL1 :CSIGnCKR= 1)

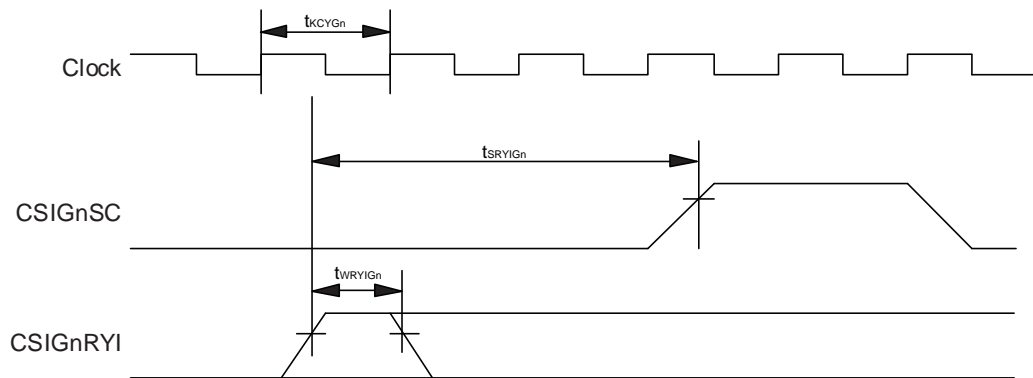

7.7.2 Slave mode

(1) CSIG timing slave mode

Table 7-3 CSIG timing (Slave mode)

Parameter	Symbol	Condition	Ratings			Unit
			Min	Typ	Max	
Macro Operation clock cycle time	tKCYGn		20.83	-	-	ns
CSIGnSC cycle time	tKCYSGn		200	-	-	ns
CSIGnSC high level width	tKWHSn		$0.5 \cdot tKCYSGn-10$	-	-	ns
CSIGnSC low level width	tKWLSn		$0.5 \cdot tKCYSGn-10$	-	-	ns
CSIGnSI setup time (vs. CSIGnSC)	tSSISn		20	-	-	ns
CSIGnSI hold time (vs. CSIGnSC)	tHSISn		$tKCYGn+5.0$	-	-	ns
SO output delay (vs SCKI)	tDSOSn		-	-	35	ns
CSIGnRYO output delay ^{a)}	tSRYOGn		-	-	35	ns
_CSIGnSSI setup time (vs. CSIGnSC)	tSSSISn		$0.5 \cdot tKCYSn-5.0$	-	-	ns
_CSIGnSSI hold time (vs. CSIGnSCI)	tHSSISn		$tKCY+5.0$	-	-	ns

a) CSIG4RYO output delay is not supported, because CSIG4RYO does not have output mode.

Note n: Number of macro instances. Refer to the User Manual for the detailed specification.

(2) Timing diagrams

SCKO / SI / SO

CSIG (CSIGnCTL1 : CSIGnCKR/ CSIGnCFG0 :CHIGnDAP0 = 0/0 or 1/1)

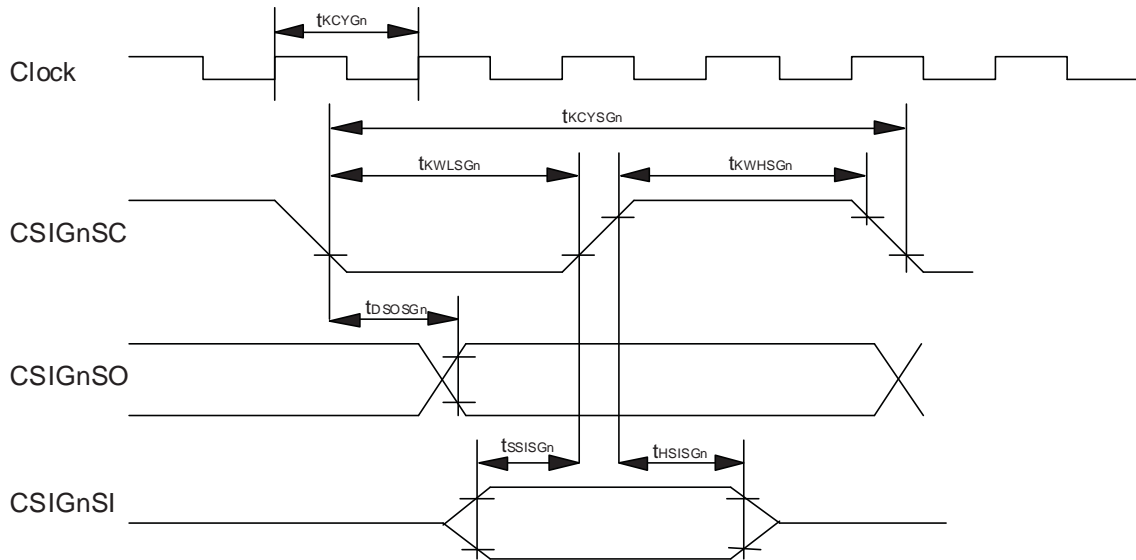

CSIG (CSIGnCTL1 : CSIGnCKR/ CSIGnCFG0 :CHIGnDAP0 = 1/0 or 0/1)

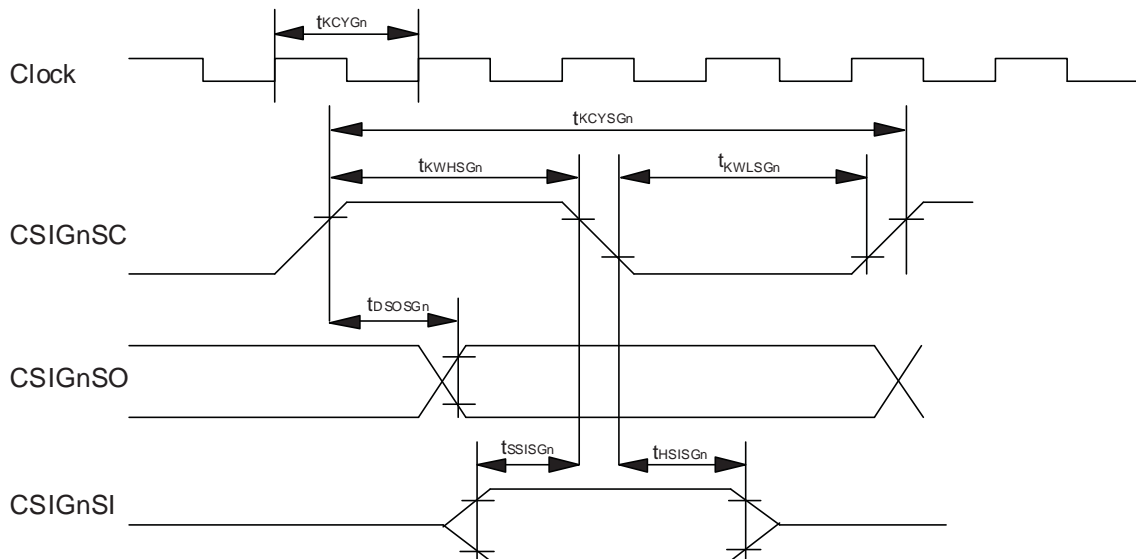

RYO

CSIG (CSIGnCTL1 : CSIGnCKR/ CSIGnCFG0 :CHIGnDAP0 = 0/0)

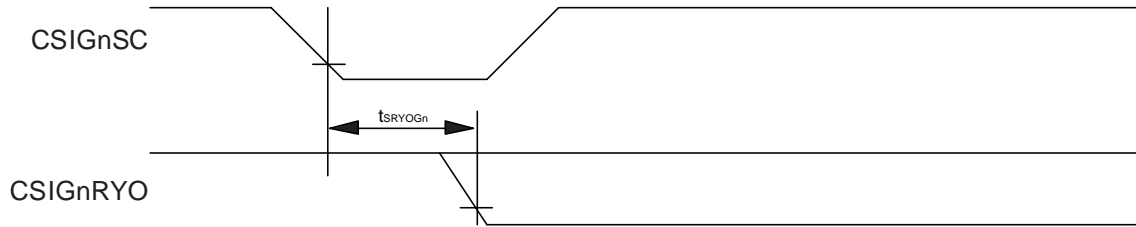

CSIG (CSIGnCTL1 : CSIGnCKR/ CSIGnCFG0 :CHIGnDAP0 = 0/1)

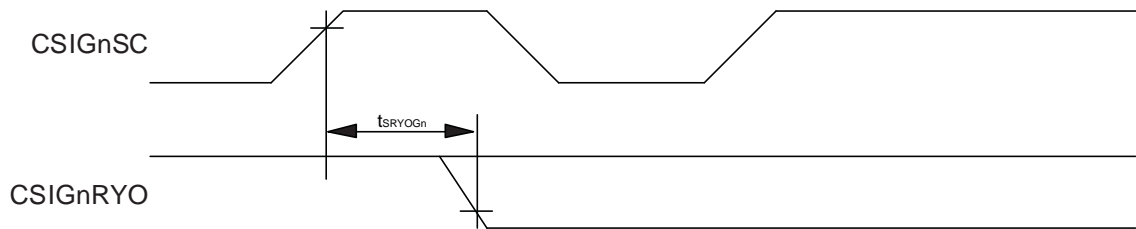

CSIG (CSIGnCTL1 : CSIGnCKR/ CSIGnCFG0 :CHIGnDAP0 = 1/0)

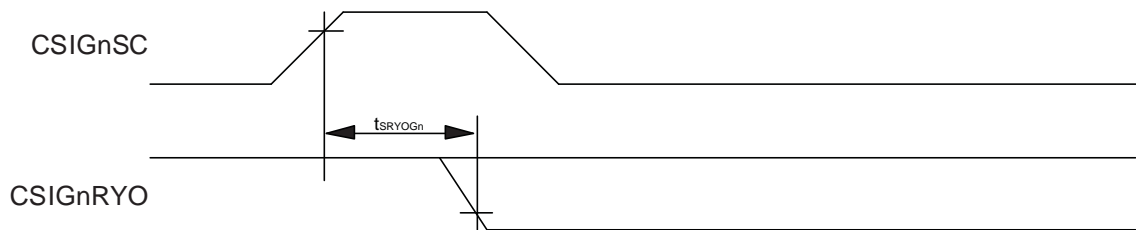

CSIG (CSIGnCTL1 : CSIGnCKR/ CSIGnCFG0 :CHIGnDAP0 = 1/1)

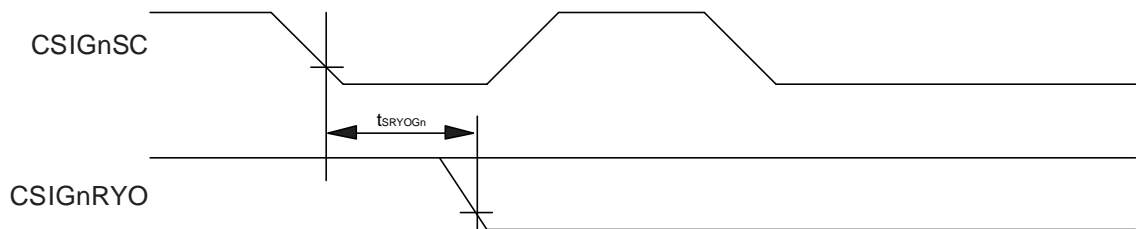

SSI:

CSIG (CSIGnCTL1 :CSIGnSSE=1, CSIGnCTL1 : CSIGnCKR,/ CSIGnCFG0 : CHIGnDAP0 = 0/0 or 1/1)

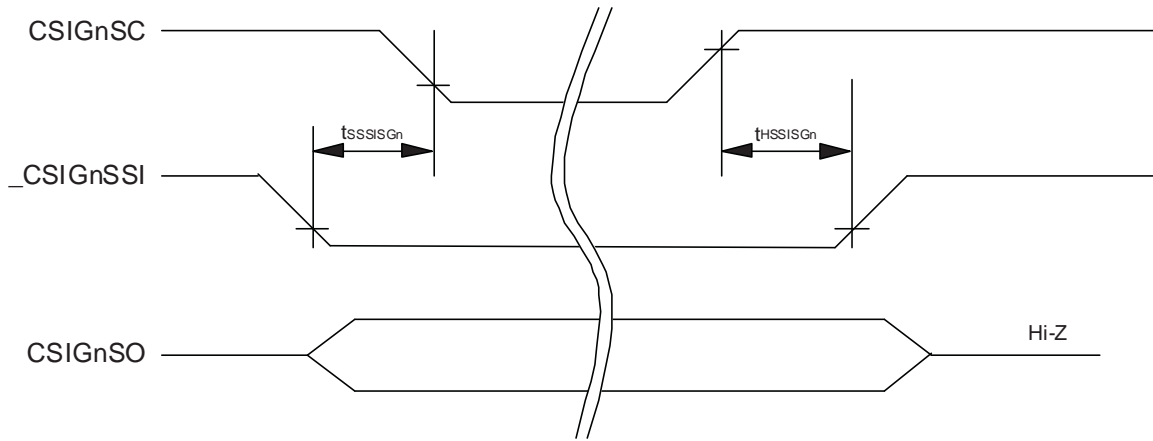

CSIG (CSIGnCTL1 :CSIGnSSE=1, CSIGnCTL1 : CSIGnCKR,/ CSIGnCFG0 : CHIGnDAP0 = 1/0 or 0/1) n=0, 4

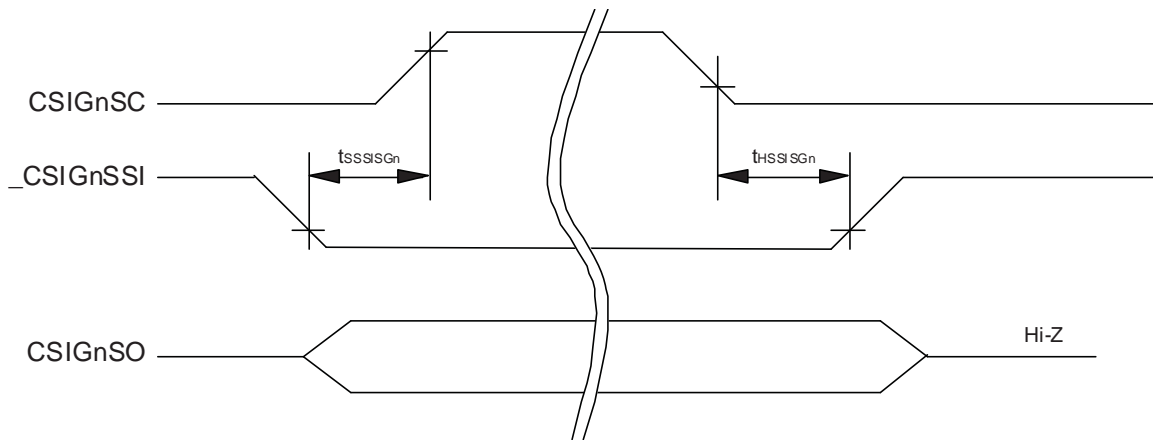

7.8 UART timing

Parameter	Symbol	Condition	Ratings			Unit
			Min	Typ	Max	
Transfer rate			-	-	1.5	Mbps

7.9 FCN timing

Parameter	Symbol	Condition	Ratings			Unit
			Min	Typ	Max	
Transfer rate			-	-	1	Mbps
Internal delay time	t _{INTDEL}		-	-	37.5	ns
CAN Node delay time	t _{NODE}	t _{CYCLE} = 62.5ns	-	-	100	ns

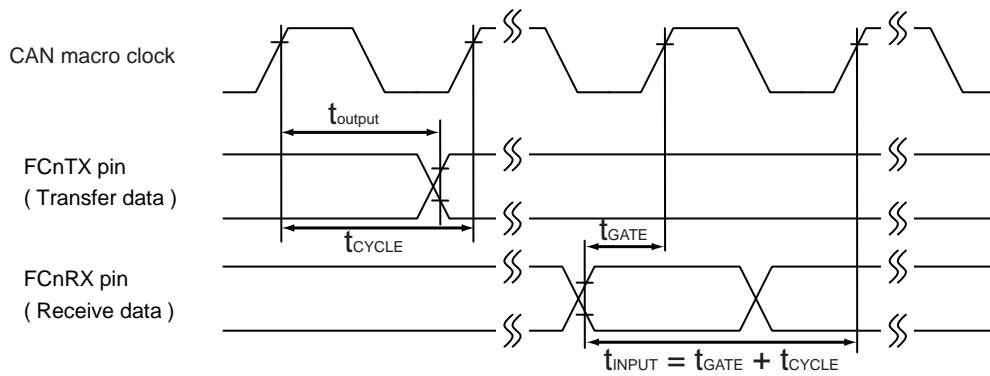

CAN node delay time (t_{NODE}) = INPUT delay time (t_{input}) + Output delay time (t_{output})
 Internal delay time (t_{INTDEL}) = Internal gate delay time (t_{GATE}) + Output delay time (t_{output})

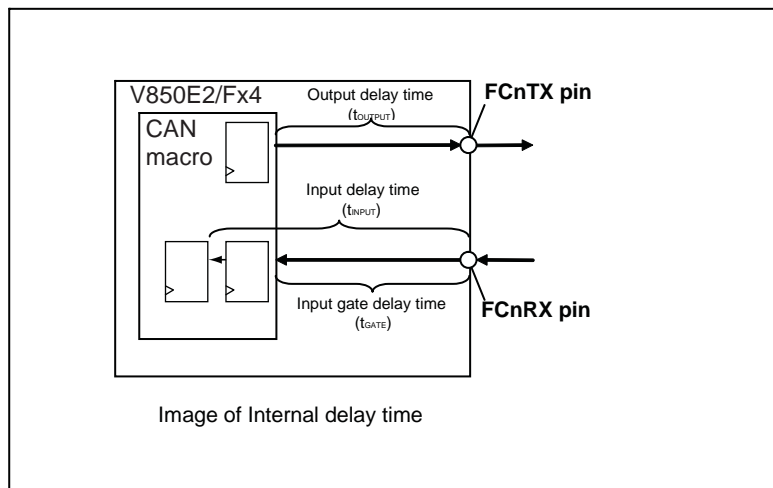

7.10 IIC timing

Table 7-4 Normal mode

Parameter	Symbol	Condition	Ratings			Unit
			Min	Typ	Max	
SCL clock period	fCLK		0		100	kHz
Bus free time (between stop condition and start condition)	tBUF		4.7	-	-	μs
Start/Restart Hold time (New clock pulse is generated after this hold time as a master.)	tHD:STA		4	-	-	μs
SCL clock low state hold time	tLOW		4.7	-	-	μs
SCL clock high state hold time	tHIGH		4	-	-	μs
Setup time for start/restart condition	tSU:STA		4.7	-	-	μs
Data hold time	tHD:DAT	CBUS compatible	5	-	-	μs
		IIC bus	0	-	-	μs
Data setup time	tSU:DAT		250	-	-	ns
Rising transition time of SDA or SCL	tR		-	-	1000	ns
Falling transition time of SDA or SCL	tF		-	-	300	ns
Setup time of stop condition	tSU:STO		4	-	-	μs
Bus capacitance	Cb		-	-	400	pF

Table 7-5 Fast mode

Parameter	Symbol	Condition	Ratings			Unit
			Min	Typ	Max	
SCL clock period	fCLK		0	-	400	kHz
Bus free time (between stop condition and start condition)	t _{BUF}		1.3	-	-	μs
Start/Restart Hold time (New clock pulse is generated after this hold time as a master.)	t _{HD:STA}		0.6	-	-	μs
SCL clock low state hold time	t _{LOW}		1.3	-	-	μs
SCL clock high state hold time	t _{HIGH}		0.6	-	-	μs
Setup time for start/restart condition	t _{SU:STA}		0.6	-	-	μs
Data hold time	t _{HD:DAT}	IIC bus	0	-	0.9	μs
Data setup time	t _{SU:DAT}		100	-	-	ns
Rising transition time of SDA or SCL	t _R		20+0.1Cb	-	300	ns
Falling transition time of SDA or SCL	t _F		20+0.1Cb	-	300	ns
Setup time of stop condition	t _{SU:STO}		0.6	-	-	μs
Noise elimination width	t _{SP}		0	-	50	ns
Bus capacitance	Cb		-	-	400	pF

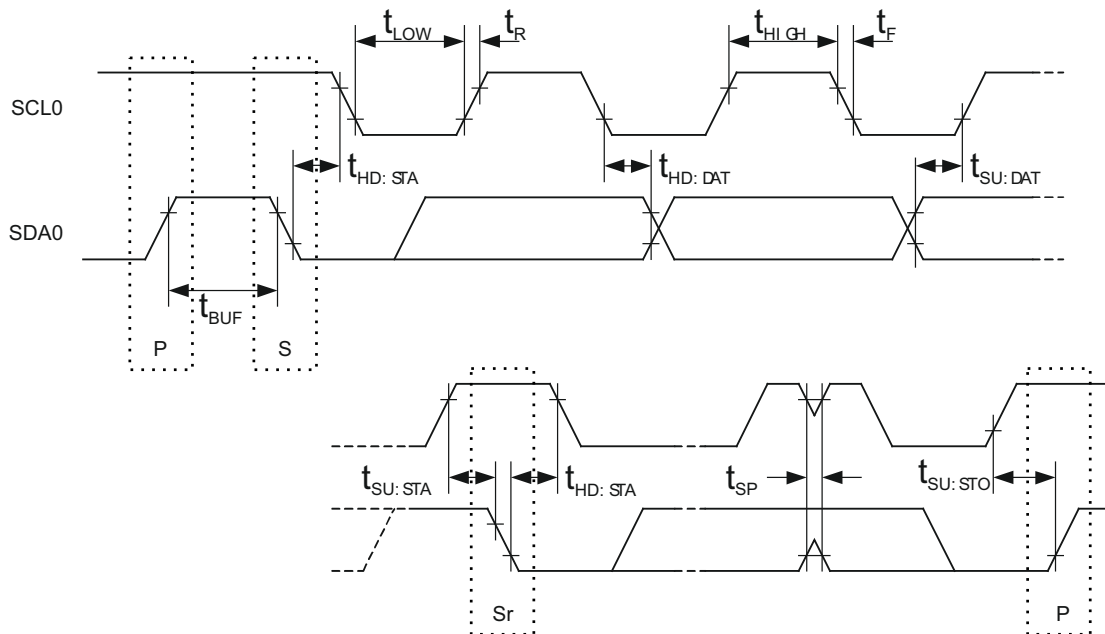

Notes 1. P: Stop condition

Notes 1. S: Start condition

Notes 1. Sr: Restart condition

7.11 VLVI characteristics

Table 7-6 VLVI characteristics

Parameter	Symbol	Condition	Ratings			Unit
			Min	Typ	Max	
Detection voltage	VRAMHF		1.75	1.9	2.0	V
Voltage slope1	Rvs1		0.18	-	1800	V/ms
Voltage slope2	Rvs2		0.0018	-	1800	V/ms
Response time ^{a)}	tRAMHD		-	-	2	ms

a) From detection voltage to setting of VLVI bit (VLVI.bit0)

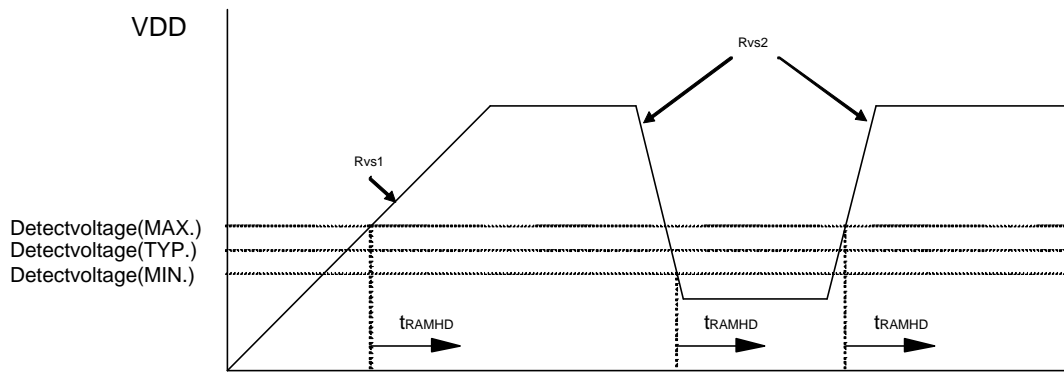

Note VDD: REG0VDD

7.12 LVI characteristics

Table 7-7 LVI characteristics

Parameter	Symbol	Condition	Ratings			Unit
			Min	Typ	Max	
Detection voltage	VLVI0	LVICNT.LVICNT[2:0]=001 _B	3.9	4.0	4.1	V
	VLVI1	LVICNT.LVICNT[2:0]=010 _B	3.6	3.7	3.8	V
	VLVI2	LVICNT.LVICNT[2:0]=011 _B	3.4	3.5	3.6	V
Voltage slope2	LVS		0.0018	-	1800	V/ms
Response time	tLD		-	-	2.0	ms
VDD minimum width	tLW		2	-	-	ms
Stabilization time	tLVIST	LVICNT0,1 is set to 1, then LVI is ready to operate	-	-	350	μs

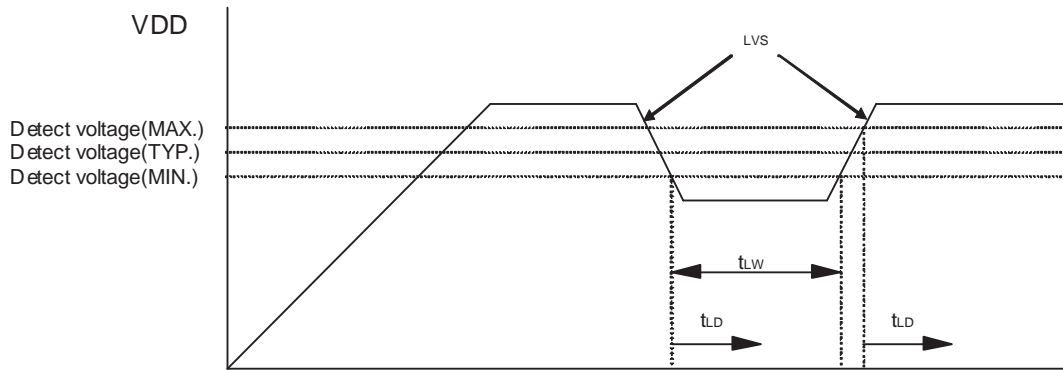

7.13 A/D Converter characteristics

7.13.1 10bit A/D

Table 7-8 10 bit A/D

Parameter	Symbol	Condition	Ratings			Unit
			Min	Typ	Max	
Resolution	RES0		10	10	10	bit
Total conversion time	TCON0		2		10	μs
Overall error	TOE0	Excluding quantization error	-	-	±3.5	LSB
Non-linearity error	ILE0		-	-	±4.0	LSB
Differential linearity error	DLE0		-	-	±1.0	LSB
Zero scale error	ZSE0		-	-	±3.5	LSB
Full scale error	FSE0		-	-	±3.5	LSB
Analog input voltage	VAIN0		A0VSS		A0VREFP	V
Power on stabilization time ^a			-	110	520	ns
A0VREFP current ^b	AIDD0		-	-	4	mA
Conversion error by Diagnosis Function			-	-	+/-20 ^c	LSB

- a) 'Power on' refers to
- setting ADCA0GPS = 1
- b) Excluding port currents
- c) Value might change after device evaluation has finished.

- Notes**
1. n: Number of macro instances. Refer to the User Manual for the detailed specification.
 2. m: Number of channels. Refer to the User Manual for the detailed specification.

- Notes**
1. n: Number of macro instances. Refer to the User Manual for the detailed specification.
 2. m: Number of channels. Refer to the User Manual for the detailed specification.

7.13.2 Equivalent circuit

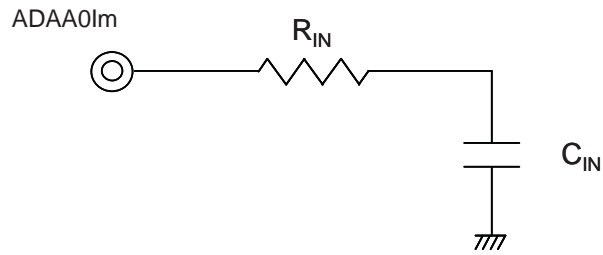

Terminals	Condition	R_{IN} [k Ω]	C_{IN} [pF]
ADAA0Im		1.2	11.9

Caution These specifications are not tested in outgoing inspection. Therefore R_{IN} and C_{IN} values are not guaranteed and are reference values only. Additionally these values are specified as maximum values.

7.13.3 ADTRG timing

Parameter	Symbol	Condition	Ratings			Unit
			Min	Typ	Max	
ADAA n TRGm input High level width	tWADH		300	-	-	ns
ADAA n TRGm input Low level width	tWADL		300	-	-	ns

- Notes**
1. n: Number of macro instances. Refer to the User Manual for the detailed specification.
 2. m: Number of channels. Refer to the User Manual for the detailed specification.

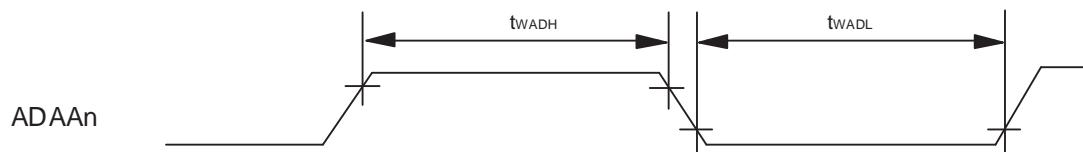

7.14 Key Return

Table 7-9

Parameter	Symbol	Condition	Ratings			Unit
			Min	Typ	Max	
KRn input High level width	tWKRH		300	-	-	ns
KRn input Low level width	tWKRL		300	-	-	ns

Note n: Number of instances. Refer to the User Manual for the detailed specification.

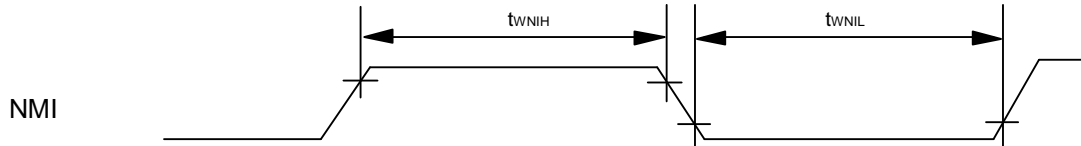

7.15 DPIN (SEQ Digital Input)

Table 7-10

Parameter	Symbol	Condition	Ratings			Unit
			Min	Typ	Max	
DPINm input High level width	tDPH		2	-	-	1/PCLK ^a
DPINm input Low level width	tDPL		2	-	-	1/PCLK

a) PCLK = Low Speed Int OSC (240kHz typ.)

Note m: Number of channels. Refer to the User Manual for the detailed specification.

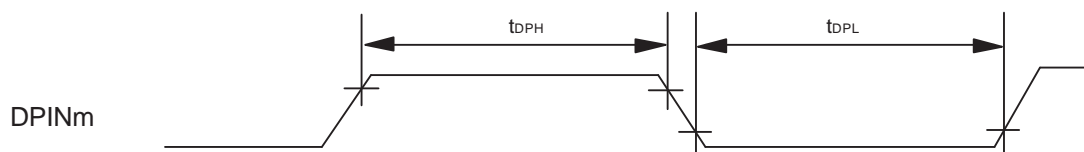

Chapter 8 Memory specification

8.1 Code flash specification

Table 8-1 Code flash

Parameter	Symbol	Condition	Ratings			Unit
			Min	Typ	Max	
Number of Re-Writes ^a	CWRT	Data retention 20 years	-	-	1000	times
Programming Temperature	tPRG	(A) grade products	-40	-	85	°C
		(A1) grade products	-40	-	110	°C
		(A2) grade products	-40	-	125	°C

a) Please contact RENESAS sales office regarding specification other than the above.

Caution Either a couple of “erase and write” operations or a programming operation for a shipped product is counted as one rewriting about initial writing.
 Shipped product -----> P → E → P → E → P : Rewriting count is 3
 Shipped product → E → P → E → P → E → P : Rewriting count is 3

8.2 Data flash specification

Table 8-2 Data flash

Parameter	Symbol	Condition	Ratings			Unit
			Min	Typ	Max	
Number of Re-Writes	DWRT	Data retention 20 years	-	-	100000	times
Programming Temperature	tPRG	(A) grade products	-40	-	85	°C
		(A1) grade products	-40	-	110	°C
		(A2) grade products	-40	-	125	°C

8.3 Serial write operation specification

Serial write operation

Parameter	Symbol	Condition	Ratings ^a			Unit
			Min	Typ	Max	
Programming time		per 128KB	-	-	2.1	s
Erase time		per 128KB	-	-	1.92	s

a) Values are for reference only

Chapter 9 Pinning and package specification

9.1 Pinning specification

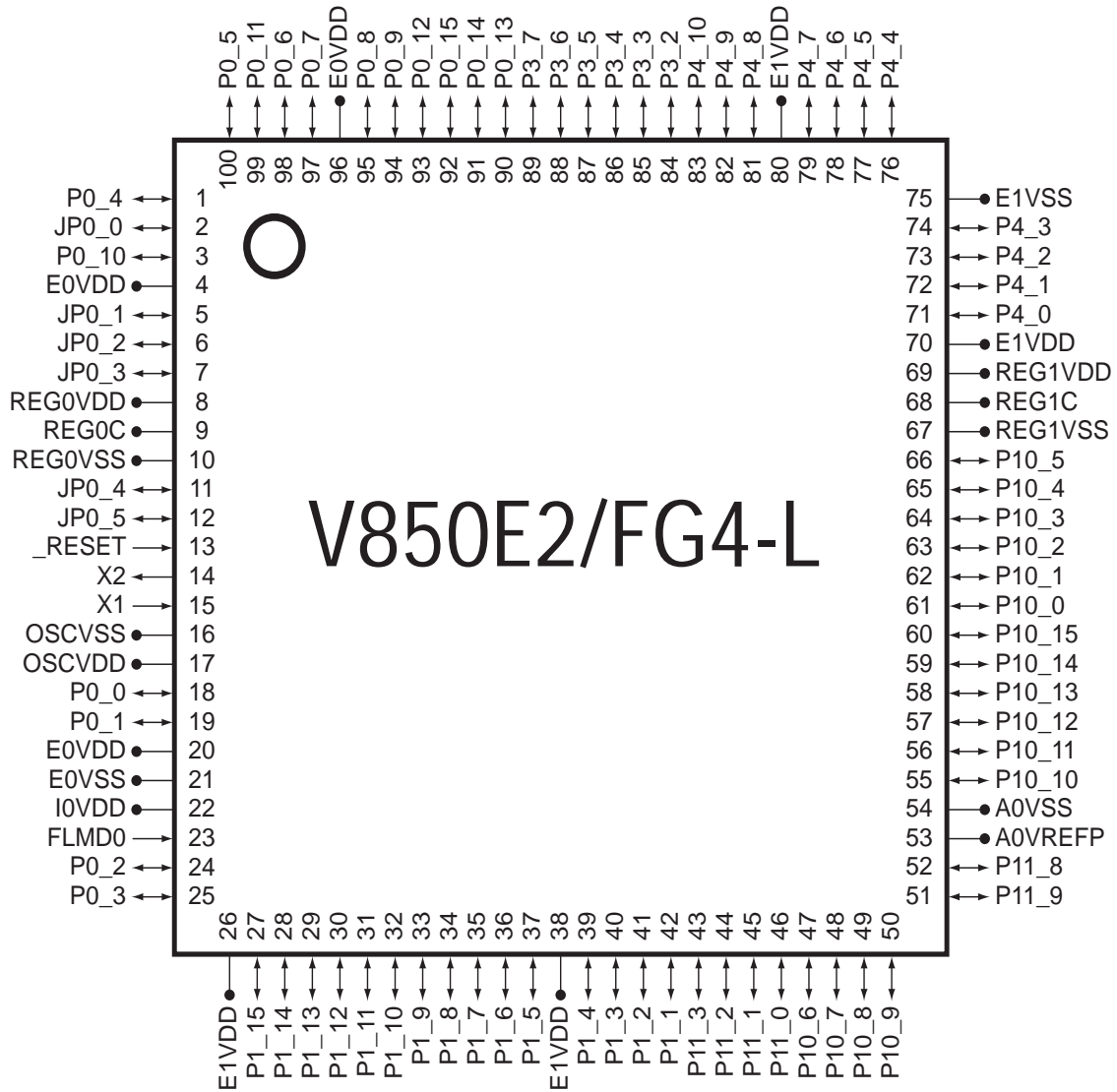

9.2 Package specification

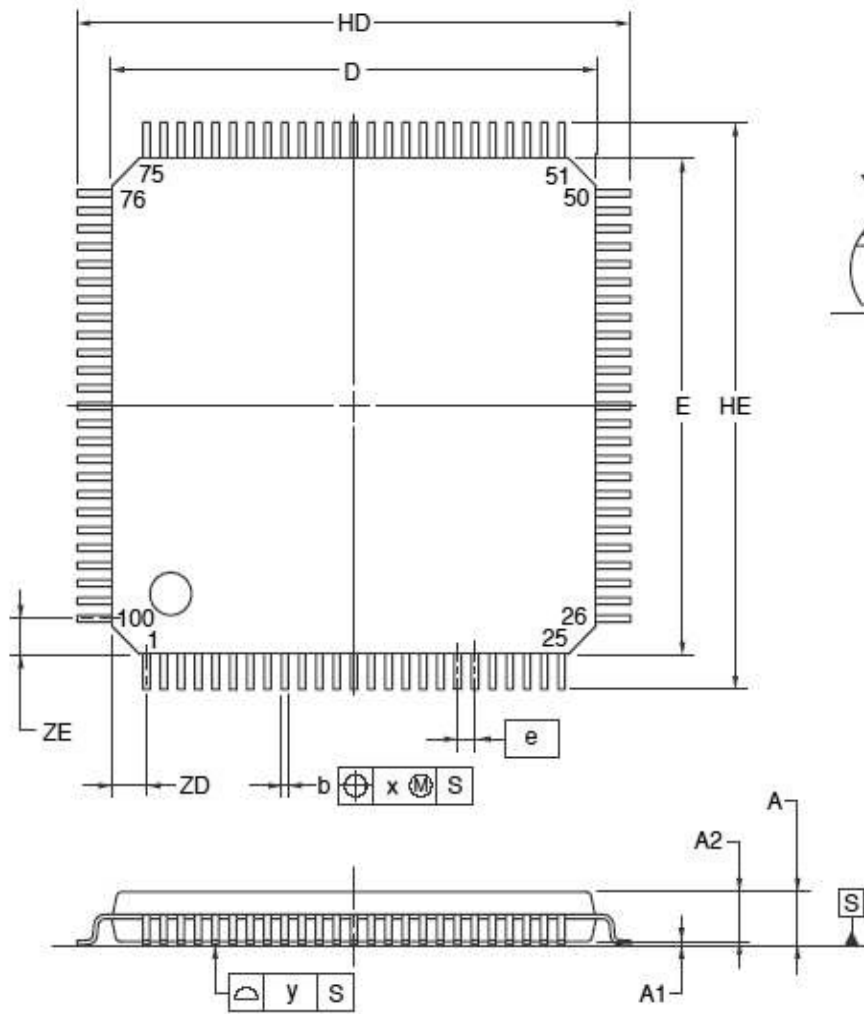

(UNIT:mm)

ITEM	DIMENSIONS
D	14.00±0.20
E	14.00±0.20
HD	16.00±0.20
HE	16.00±0.20
A	1.60 MAX.
A1	0.10±0.05
A2	1.40±0.05
A3	0.25
b	0.20 ^{+0.07} _{-0.03}
c	0.125 ^{+0.075} _{-0.025}
L	0.50
Lp	0.60±0.15
L1	1.00±0.20
θ	3° ^{+5°} _{-3°}
e	0.50
x	0.08
y	0.08
ZD	1.00
ZE	1.00

P100GC-50-UEU-1

Revision History

Version	Date	Document number	Major changes
1.0	2012-08-30	R01DS0147ED0100	Initial release (previous document was EASE-DS-0035-1.2)
1.01	2013-09-10	R01DS0147ED0101	Chapter 3: - CPU Start-up time $T_{cpu\ start}$ was 750 μ s typ. - VPOC was 2.80V min. Chapter 7: - VLVI Detection Voltage V_{RAMHF} was 1.80V min. - Added DPIN characteristics
1.02	2014-04-21	R01DS0147EJ0102	Throughout: - Changed pin name A0VDD/AnVDD to A0VREFP Chapter 3: - Deleted timing charts of ISO Regulator characteristics Chapter 5: - Deleted CMOS1 descriptions from VIH and VIL of PgE1. - Deleted Analog noise filter section. Chapter 6: - Deleted supply current specifications of μ PD70F3576 to μ PD70F3579 Chapter 7: - Added timing chart to reset timing - Corrected pin name and symbols in timing chart of NMI timing Chapter 8: - Added caution to code flash specification