

TLE4959-5U-SP Transmission Speed Sensor



Features

- Hall based differential speed sensor
- High magnetic sensitivity
- Large operating airgap
- Dynamic self-calibration principle
- Adaptive hysteresis threshold
- High vibration suppression capabilities
- Three wire voltage interfaces
- Magnetic encoder and ferromagnetic wheel application
- High immunity against ESD, EMC and mechanical stress, improved voltage dropout capability
- Automotive operating temperature range
- 4-pin package PG-SSO-4-1
- Green Product (RoHS compliant)
- AEC Qualified

Applications

The TLE4959-5U-SP is an integrated differential Hall speed sensor ideally suited for transmission applications. Its basic function is to provide information about rotational speed to the transmission control unit. TLE4959-5U-SP includes a sophisticated algorithm which actively suppresses vibration while keeping excellent airgap performance.

Table 1 Description

Type	Marking	Ordering Code	Package
TLE4959-5U-SP	59AY2A	SP004842810	PG-SSO-4-1

Description

Description

The TLE4959-5U-SP comes in a RoHS compliant four-pin package, qualified for automotive usage. The recommended capacitors increase the EMC robustness of the device. In 12 V applications it is further recommended to use a serial resistor R_{Supply} for protection on the supply line. A pull-up resistor R_{Load} is mandatory on the output pin and determines the maximum current flowing through the output transistor. A value of 1.2 k Ω is recommended for the 5 V application (see Figure 1).

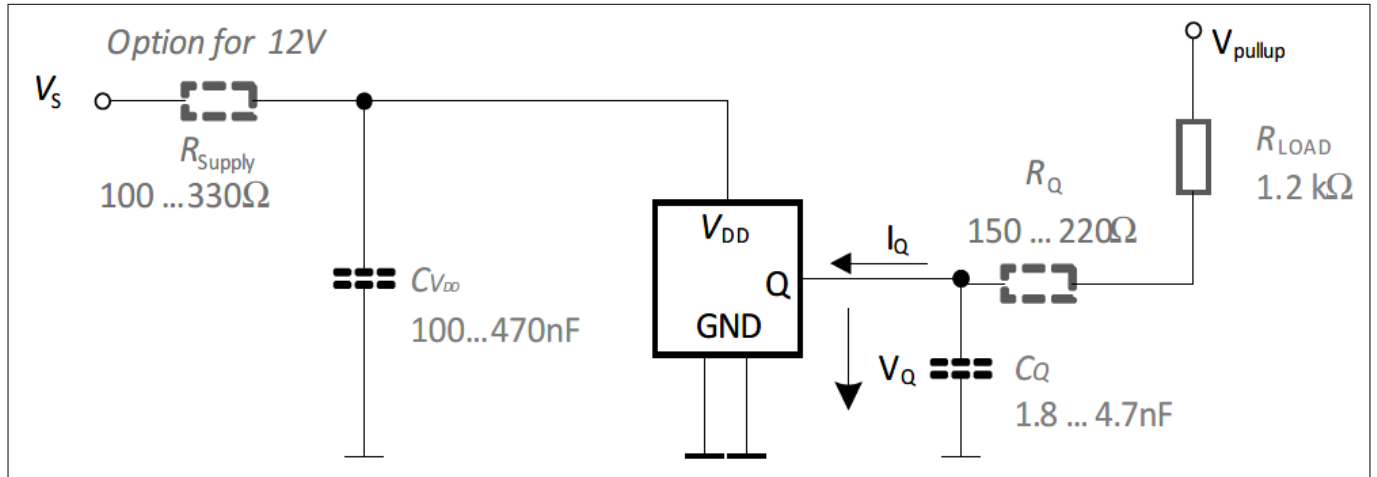

Figure 1 Typical Application Circuit

Table of contents

Table of contents

	Table of contents	3
1	Functional Description	4
1.1	Definition of the Magnetic Field Direction	4
1.2	Block Diagram	4
1.3	Basic Operation	5
1.4	Uncalibrated and Calibrated Mode	5
1.5	Hysteresis Concept	5
1.6	Vibration Suppression	6
2	General Characteristics	7
2.1	Absolute Maximum Ratings	7
2.2	Operating Range	7
3	Electrical and Magnetic Characteristics	9
4	Package Information	11
4.1	Package Outline	11
4.2	Marking and Data Matrix Code	13
4.3	Packing Information	14
	Revision history	15
	Disclaimer	16

1 Functional Description

1 Functional Description

The differential Hall sensor IC detects the motion of tooth and magnet encoder applications. To detect the motion of ferromagnetic objects, the magnetic field must be provided by a back biasing permanent magnet. Either south or north pole of the magnet can be attached to the rear unmarked side of the IC package (see Figure 2). The magnetic measurement is based on three equally spaced Hall elements, integrated on the IC. Both magnetic and mechanical offsets are cancelled by a self-calibration algorithm. The device is a factory pre-programmed version for providing the rotational speed information only.

1.1 Definition of the Magnetic Field Direction

The magnetic field of a permanent magnet exits from the north pole and enters the south pole. If a north pole is attached to the backside of the High-End Transmission Sensor, the field at the sensor position is positive, as shown in Figure 2.

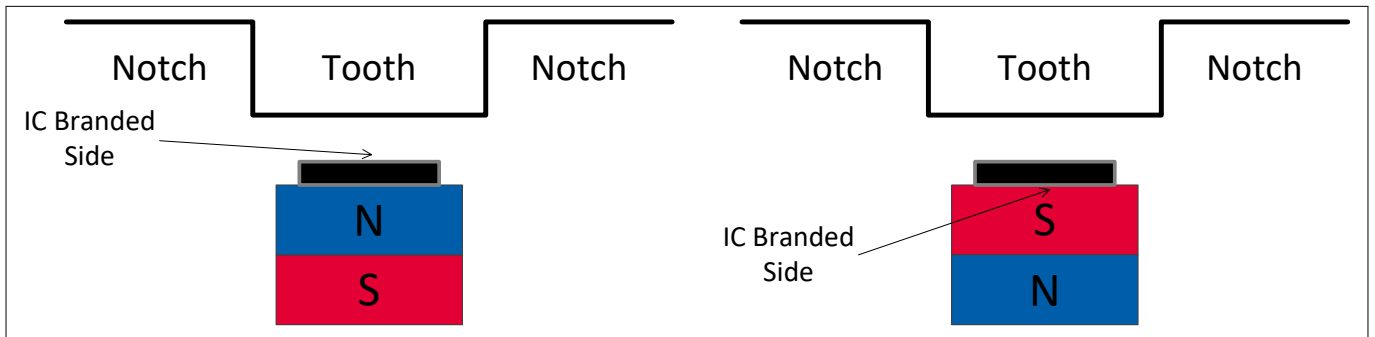

Figure 2 Definition of the Positive Magnetic Field Direction

1.2 Block Diagram

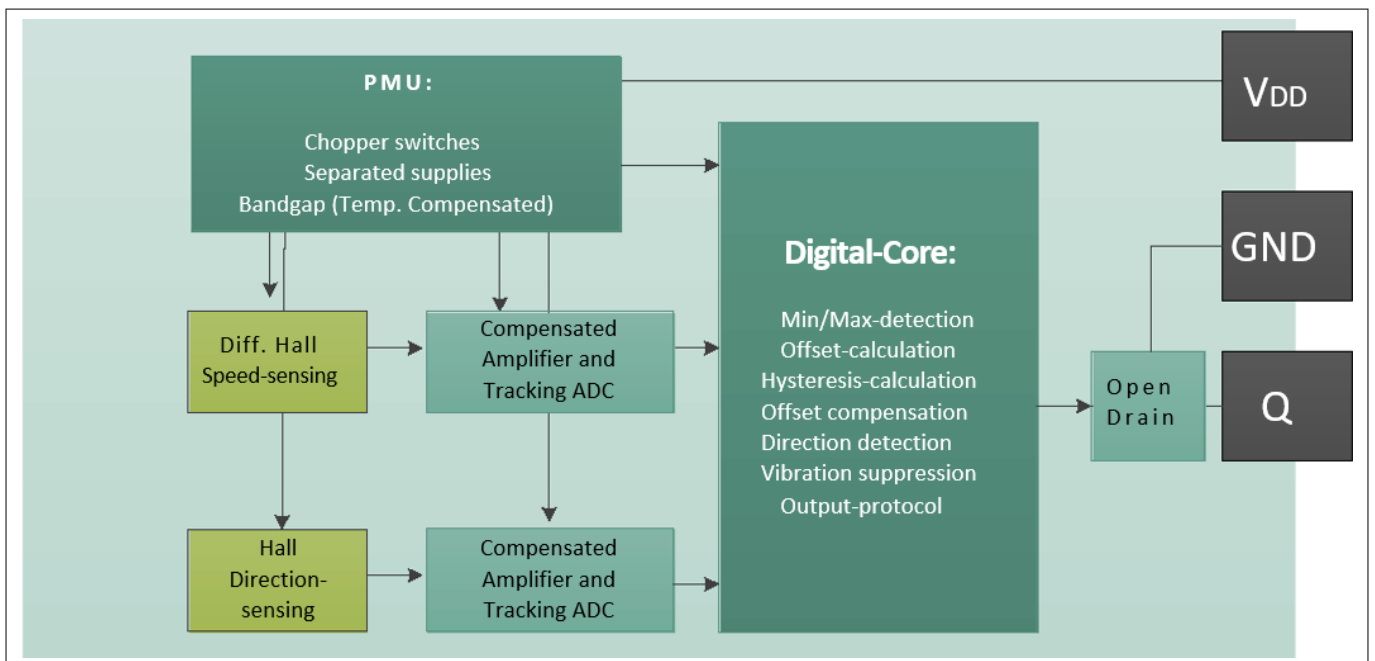

Figure 3 Block Diagram

1 Functional Description

1.3 Basic Operation

The speed signal calculated out of the differential hall elements, is amplified, filtered and digitized. An algorithm in the digital core for peak detection and offset calculation will be executed. The offset is fed back into the speed signal path with a digital to analog converter for offset correction. During uncalibrated mode, the output of the speed pulse is triggered in the digital core by exceeding a certain threshold of the tracking ADC. In calibrated mode the output is triggered by the visible hysteresis.

The direction signal is calculated out of center Hall signals. The direction signal is amplified, filtered, and digitized. In the digital core, the direction signal is used for the vibration detection.

1.4 Uncalibrated and Calibrated Mode

After power on the differential magnetic speed signal is tracked by an analog to digital converter (Tracking ADC) and monitored within the digital core. If the signal slope is identified as a rising edge or falling edge, the first output pulse is triggered.

In uncalibrated mode, the output protocols are triggered by the DNC (digital noise constant) in the speed path. After start up the sensor switches with the DNC_{min} value and after that the DNC is adapted to 1/8 of the magnetic input signal amplitude.

The offset update starts if two valid extrema values are found and the direction of the update has the same orientation as the magnetic signal. For example, a positive offset update is being issued on a rising magnetic edge only. After a successful offset correction, the sensor is in calibrated mode. Switching occurs at the adaptive hysteresis threshold level.

In calibrated mode, the DNC is adapted to 1/8 of the magnetic input signal amplitude with a minimum of DNC_{min} . The output pulses are then triggered with adaptive hysteresis.

1.5 Hysteresis Concept

The adaptive hysteresis is linked to the input signal. Therefore, the system is able to suppress switching if vibration or noise signals are smaller than the adaptive hysteresis levels. The typical value for the hysteresis level is 1/8 of the magnetic input peak-to-peak signal, the minimum hysteresis level is HYS_{min} .

The visible hysteresis keeps the excellent performance in large pitch transmission application wheels.

1 Functional Description

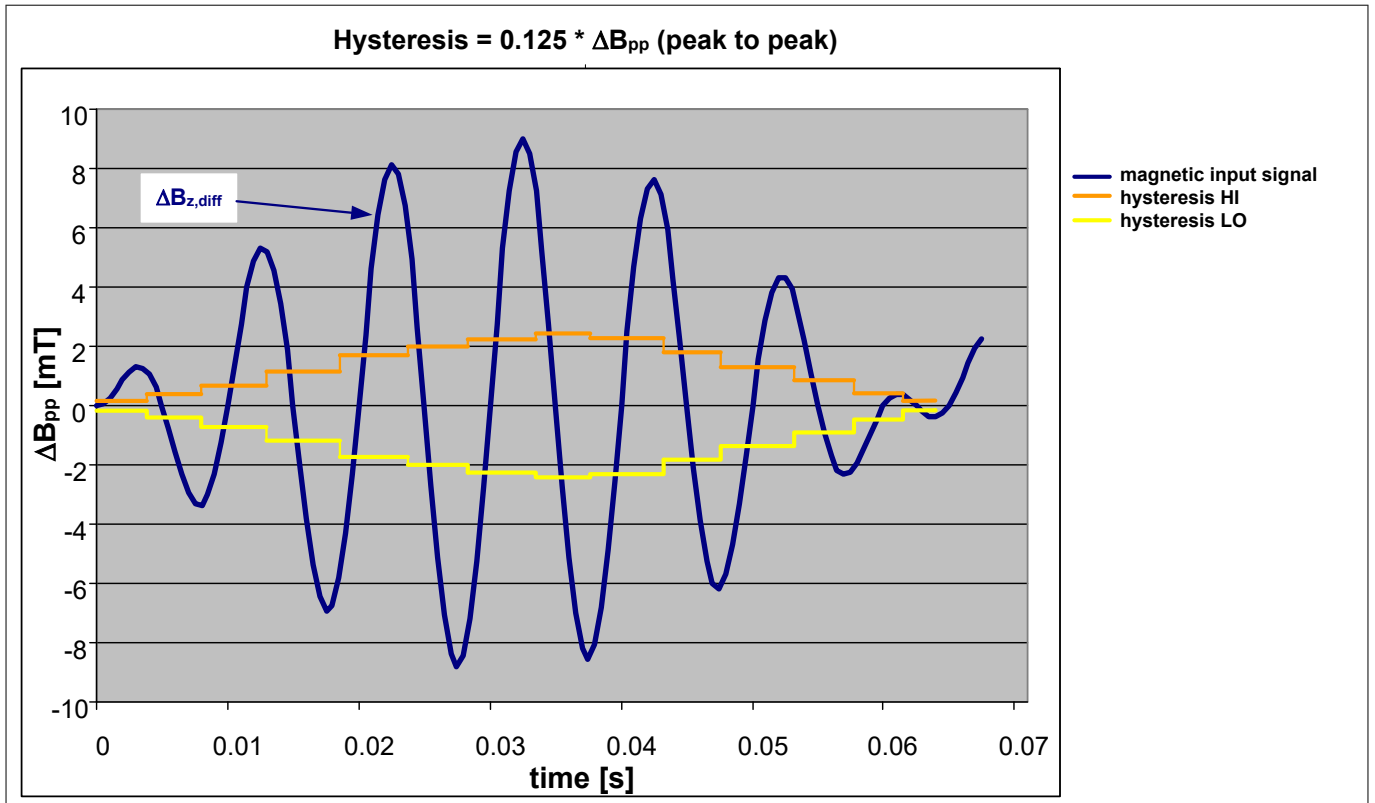

Figure 4 Adaptive Hysteresis

1.6 Vibration Suppression

The direction signal is digitized by an analog to digital converter (direction ADC) and fed into the digital core. Depending upon the rotation direction of the target wheel, the signal of the center probe anticipates or lags behind for 90°. This phase relationship is evaluated and converted into rotation direction information by sampling the signal of the center probe in the proximity of the zero crossing of the “speed” bridge signal.

The magnetic signal amplitude and the direction information are used for detection of parasitic magnetic signals. Unwanted magnetic signal can be caused by angular or air gap vibrations. If an input signal is identified as a vibration the output pulse will be suppressed.

2 General Characteristics

2 General Characteristics

2.1 Absolute Maximum Ratings

Table 2 Absolute Maximum Ratings

Parameter	Symbol	Values			Unit	Note or Test Condition
		Min.	Typ.	Max.		
Supply voltage without supply resistor	V_{DD}	-16	-	18	V	continuous, $T_J \leq 175^\circ\text{C}$
		-	-	27	V	max. 60 s, $T_J \leq 175^\circ\text{C}$
		-18	-	-	V	max. 60 s, $T_J \leq 175^\circ\text{C}$
Output OFF voltage	V_{Q_OFF}	-1.0	-	-	V	max. 1 h, $T_{Amb} \leq 40^\circ\text{C}$
		-0.3	-	26.5	V	continuous, $T_J \leq 175^\circ\text{C}$
Output ON voltage	V_{Q_ON}	-	-	16	V	continuous, $T_{Amb} \leq 40^\circ\text{C}$
		-	-	18	V	max. 1 h, $T_{Amb} \leq 40^\circ\text{C}$
		-	-	26.5	V	max. 60 s, $T_{Amb} \leq 40^\circ\text{C}$
Junction temperature range	T_J	-40	-	185	$^\circ\text{C}$	exposure time: max. 10×1 h, $V_{DD} = 16$ V
Magnetic field induction	B_Z	-5	-	5	T	magnetic pulse during magnet magnetization. Valid 10 s with $T_{ambient} \leq 80^\circ\text{C}$
ESD compliance	ESD_{HBM}	-2	-	2	kV	HBM ¹⁾

1) ESD susceptibility, HBM according to EIA/JESD 22-A114B

Note: Stresses above the max values listed here may cause permanent damage to the device. Exposure to absolute maximum rating conditions for extended periods may affect device reliability. Maximum ratings are absolute ratings; exceeding only one of these values may cause irreversible damage to the integrated circuit.

2.2 Operating Range

All parameters specified in the following sections refer to these operating conditions unless otherwise specified.

Table 3 General Operating Conditions

Parameter	Symbol	Values			Unit	Note or Test Condition
		Min.	Typ.	Max.		
Supply voltage without supply resistance R_s	V_{DD}	4.0	-	16	V	
Continuous Output Off voltage	V_{Q_OFF}	-	-	16	V	
Supply voltage power- up/down voltage ramp	dV_{DD}/dt	3.0	-	1e4	V/ms	

(table continues...)

2 General Characteristics

Table 3 (continued) General Operating Conditions

Parameter	Symbol	Values			Unit	Note or Test Condition
		Min.	Typ.	Max.		
Supply current	I_{DD}	8.0	–	13.4	mA	
Continuous output On current	I_{Q_ON}	–	–	15	mA	$V_{Q_LOW} < 0.5 V$
Magnetic signal frequency range	f	0	–	10	kHz	
		10	–	22	kHz	Extended range. Degraded accuracy performance
Dynamic range of the magnetic field of the differential speed channel	$DR_{mag_field_s}$	-120	–	120	mT	
Dynamic range of the magnetic field of the direction channel	$DR_{mag_field_dir}$	-60	–	60	mT	
Static range of the magnetic field of the outer Hall probes	$SR_{mag_field_s}$	0	–	550	mT	
Static range of the magnetic field of the center Hall probe	$DR_{mag_field_dir}$	-100	–	450	mT	
Allowed static difference between outer probes	$SR_{mag_field_diff}$	-30	–	30	mT	
Normal operating junction temperature	T_J	-40	–	175	°C	exposure time: max. 2500 h at $T_J = 175^\circ C$, $V_{DD} = 16 V$
		–	–	185	°C	exposure time: max. $10 \times 1 h$ at $T_J = 185^\circ C$, $V_{DD} = 16 V$, additive to other lifetime
Not operational lifetime	T_{no}	-40	–	150	°C	without sensor function; exposure time max 500 h at $150^\circ C$; increased time for lower temperatures according to Arrhenius-Model, additive to another lifetime
Temperature compensation range of magnetic material	TC	–	-800	–	ppm	internal compensation of magnetic signal amplitude of speed signal

Note: In the operating range the functions given in the functional description are fulfilled.

3 Electrical and Magnetic Characteristics

3 Electrical and Magnetic Characteristics

All values specified at constant amplitude and offset of input signal, over operating range, unless otherwise specified. Typical values correspond to $V_S = 5\text{ V}$ and $T_{Amb} = 25^\circ\text{C}$.

Table 4 Electrical and Magnetic Parameters

Parameter	Symbol	Values			Unit	Note or Test Condition
		Min.	Typ.	Max.		
Output saturation voltage	V_{Qsat}	0	–	500	mV	$I_Q \leq 15\text{ mA}$
Clamping voltage V_{DD} -Pin	V_{DD_clamp}	42	–	–	V	leakage current through ESD diode $< 0.5\text{ mA}$
Clamping voltage V_Q -Pin	V_{Qclamp}	42	–	–	V	leakage current through ESD diode $< 0.5\text{ mA}$
Reset voltage	V_{DD_reset}	2.8	–	3.6	V	
Output leakage current	I_{Qleak}	0	0.1	10	μA	$V_Q = 18\text{ V}$
Output current limit during short-circuit condition	I_{Qshort}	30	–	80	mA	
Junction temperature limit for output protection	T_{prot}	190	–	205	$^\circ\text{C}$	
Power on time	t_{power_on}	0.8	0.9	1	ms	during this time the output is locked to high.
Delay time between magnetic signal switching point and corresponding output signal falling edge switching event	t_{delay}	10	14	19	μs	
Output fall time	t_{fall}	2.0	2.5	3.0	μs	$V_{Pullup} = 5\text{ V}$, $R_{Pullup} = 1.2\text{ k}\Omega$ (+/-10%), $C_Q = 1.8\text{ nF}$ (+/-15%), valid between 80% - 20%
		3.2	4.5	5.8	μs	$V_{Pullup} = 5\text{ V}$, $R_{Pullup} = 1.2\text{ k}\Omega$ (+/-10%), $C_Q = 1.8\text{ nF}$ (+/-15%), valid between 90% - 10%
Output rise time	$t_{rise}^{1)}$	4	–	11.4	μs	$R_{Pullup} = 1.2\text{ k}\Omega$ (+/-10%), $C_Q = 1.8\text{ nF}$ (+/-15%), valid between 10% - 90%
Digital noise constant of speed channel during start up	DNC_{min}	1.22	1.5	1.78	mT	
Minimum hysteresis threshold	HYS_{min}	1.22	1.5	1.78	mT	
Duty Cycle in calibrated mode ²⁾	Dty	40	–	60	%	on sinusoidal signals
Period Jitter, $f \leq 8\text{ kHz}$ ³⁾	Jit_{8kHz}	-1	–	1	%	1 sigma, $\Delta B_{pkpk} = 3\text{ mT}$
Period Jitter, $8\text{ kHz} \leq f \leq 10\text{ kHz}$ ³⁾	Jit_{10kHz}	-1.1	–	1.1	%	1 sigma, $\Delta B_{pkpk} = 3\text{ mT}$
Global run out ⁴⁾	$Runout_{global, speed}$	0	–	40	%	of magnetic speed signal amplitude

(table continues...)

3 Electrical and Magnetic Characteristics

Table 4 (continued) Electrical and Magnetic Parameters

Parameter	Symbol	Values			Unit	Note or Test Condition
		Min.	Typ.	Max.		
		0	–	60	%	of magnetic speed signal amplitude with reduced performance on stop-start-functionality
	$Runout_{global,dir}$	0	–	40	%	of magnetic direction signal amplitude
		0	–	60	%	of magnetic direction signal amplitude with reduced performance on stop-start-functionality
Tooth to tooth run out (peak to peak variation on two consecutive teeth / pole-pair) ⁴⁾	$Runout_{tooth, speed}$	0	–	40	%	of magnetic speed signal amplitude
	$Runout_{tooth, dir}$	0	–	40	%	of magnetic direction signal amplitude

- 1) Application parameter, IC shall not increase the rise time, Values are calculated and not tested
- 2) During fast offset alterations, due to the calibration algorithm, exceeding the specified duty cycle is permitted for short time periods. Parameter not subject to production test, verify by design/characterization.
- 3) Parameter not subject to productive test. Verified by lab characterization based on jitter-measurement > 1000 periods
- 4) Defined as 1-(amplitude_min/amplitude_max)

Note: The listed Electrical and magnetic characteristics are ensured over the operating range of the integrated circuit. Typical characteristics specify mean values expected over the production spread. If not other specified, typical characteristics apply at $T_{Amb} = 25^{\circ}C$ and $V_S = 5 V$.

4 Package Information

4 Package Information

Pure tin covering (green lead plating) is used. The product is RoHS (Restriction of Hazardous Substances) compliant and marked with letter G in front of the data code marking and may contain a data matrix code on the rear side of the package. Please refer to your key account team or regional sales if you need further information.

The specification for soldering and welding is defined in the latest revision of application note “Recommendation for Board Assembly-Hallsensor SSO Packages”.

4.1 Package Outline

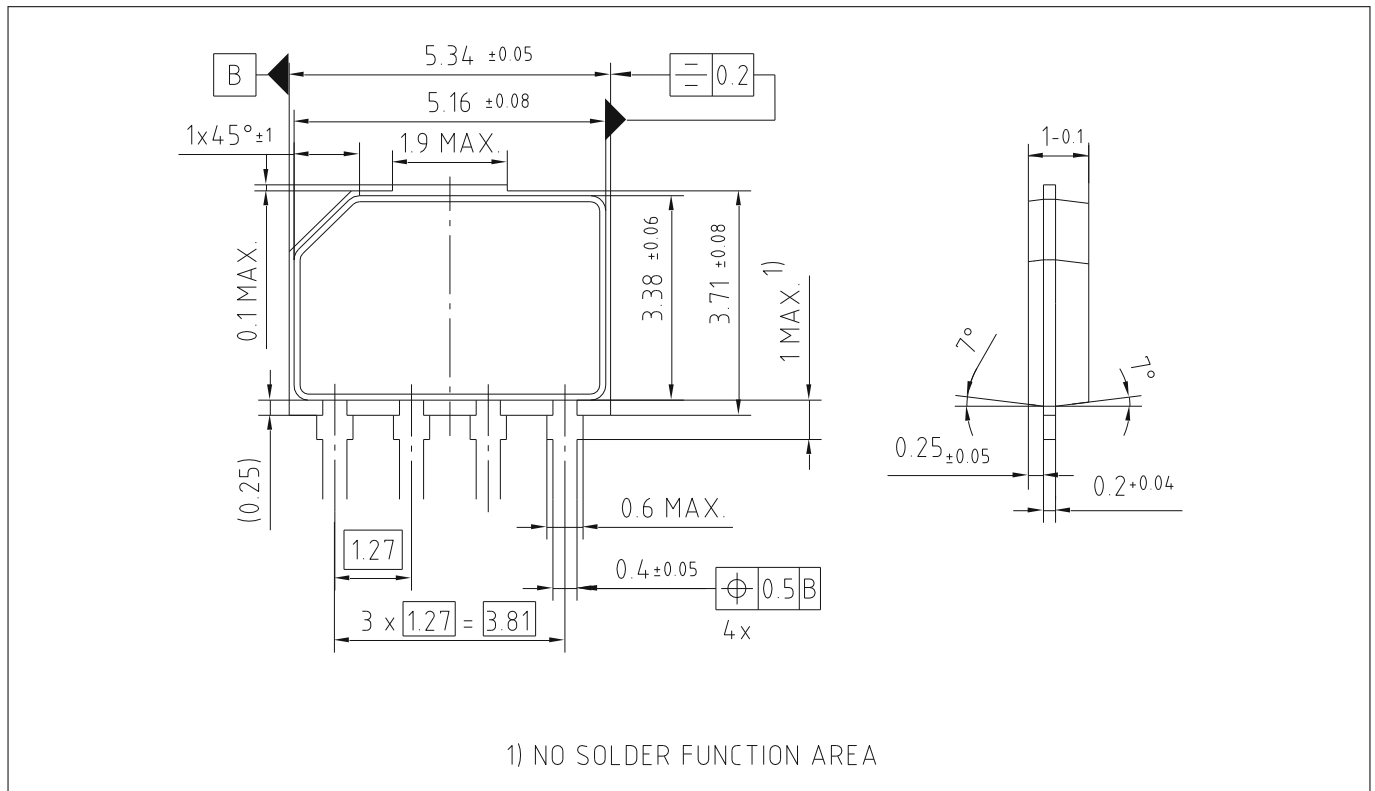

Figure 5 PG-SSO-4-1 (Plastic Green Single Slim Outline), Package Dimensions

4 Package Information

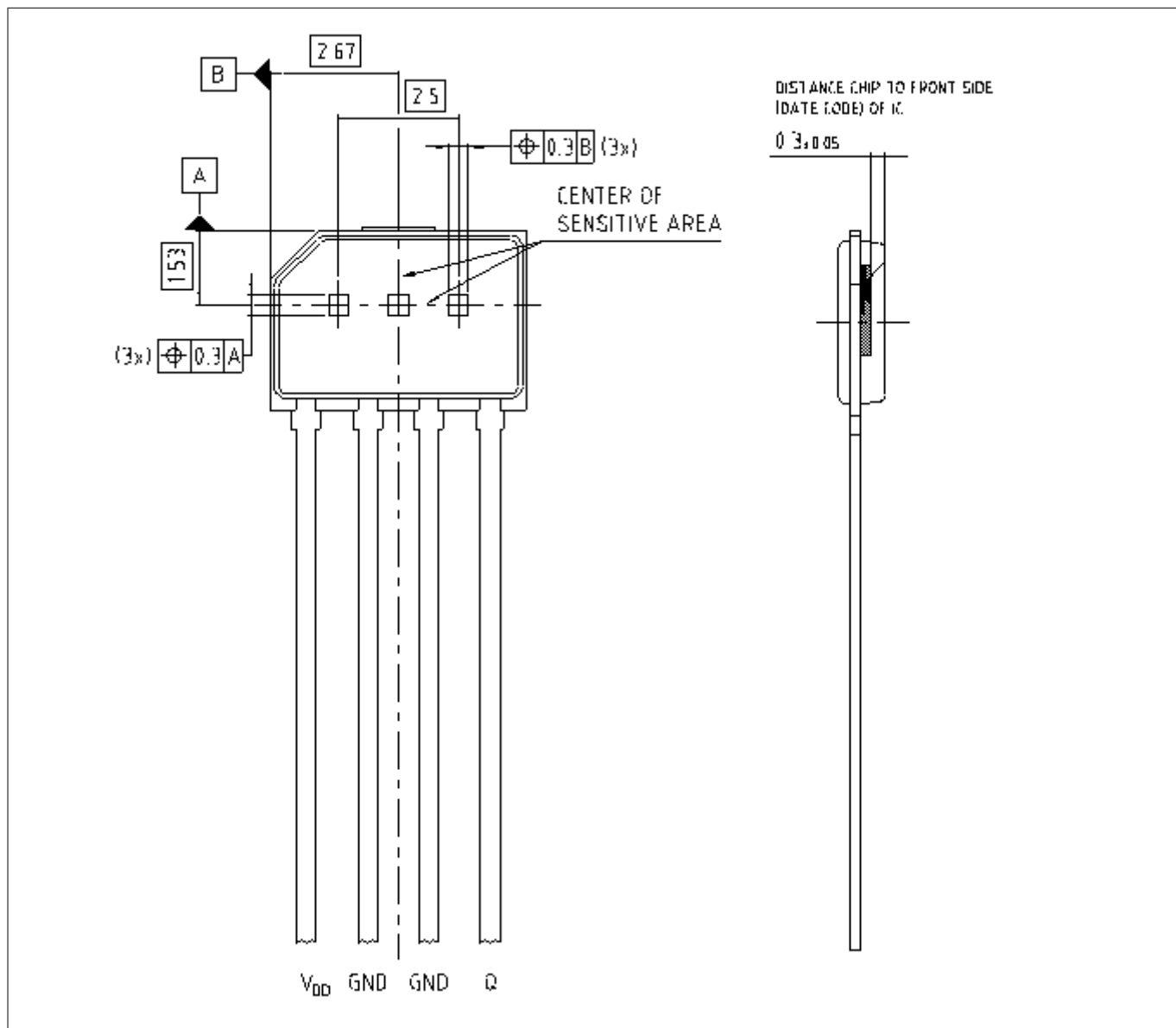

Figure 6 Position of the Hall Elements and distance to the branded Side

4 Package Information

4.2 Marking and Data Matrix Code

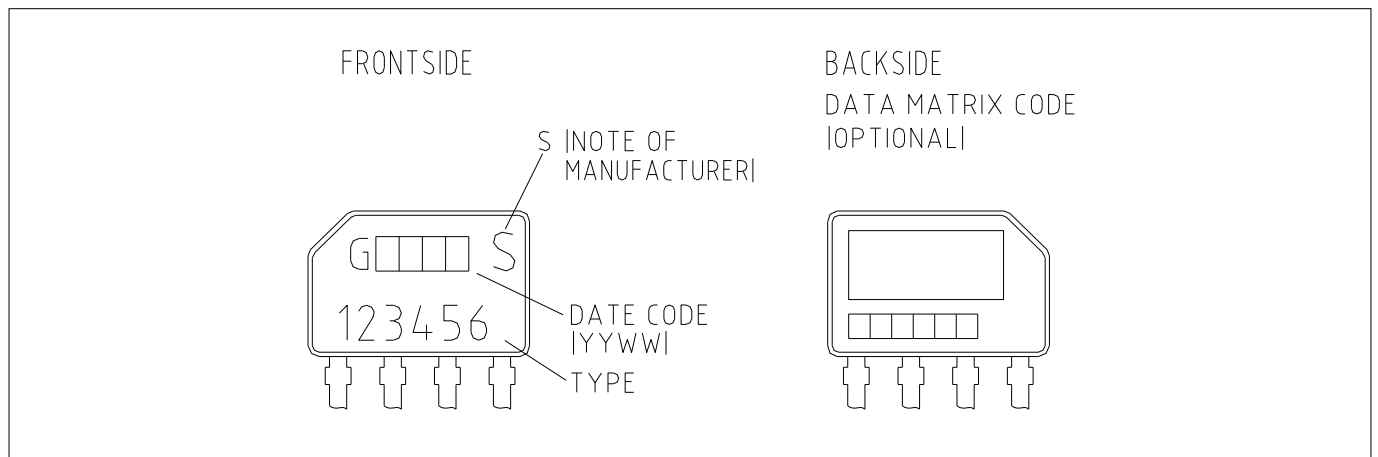

Figure 7 Marking of PG-SSO-4-1 Package

Table 5 Pin Description

Pin Number ¹⁾	Symbol	Function
1	V _{DD}	Supply Voltage
2	GND	Ground
3	GND	Ground
4	Q	Open Drain Output

1) Refer to frontside view: leftmost pin corresponding to pin number 1

Revision history**Revision history**

Document revision	Date	Description of changes
1.1	2019-08-01	<ul style="list-style-type: none">• Marking updated
1.2	2025-03-05	<ul style="list-style-type: none">• Table 3: Magnetic signal frequency range extended to 22 kHz• Table 4: Minimum hysteresis threshold parameter HYS_{min} added• Table 4: Number of wrong pulses at start-up, parameter n_{Start} deleted• Editorial changes

Trademarks

All referenced product or service names and trademarks are the property of their respective owners.

Edition 2025-03-05

Published by

Infineon Technologies AG

81726 Munich, Germany

© 2025 Infineon Technologies AG

All Rights Reserved.

Do you have a question about any aspect of this document?

Email: erratum@infineon.com

Document reference

IFX-iom1740745607042

Important notice

The information given in this document shall in no event be regarded as a guarantee of conditions or characteristics ("Beschaffheitsgarantie").

With respect to any examples, hints or any typical values stated herein and/or any information regarding the application of the product, Infineon Technologies hereby disclaims any and all warranties and liabilities of any kind, including without limitation warranties of non-infringement of intellectual property rights of any third party.

In addition, any information given in this document is subject to customer's compliance with its obligations stated in this document and any applicable legal requirements, norms and standards concerning customer's products and any use of the product of Infineon Technologies in customer's applications.

The data contained in this document is exclusively intended for technically trained staff. It is the responsibility of customer's technical departments to evaluate the suitability of the product for the intended application and the completeness of the product information given in this document with respect to such application.

Warnings

Due to technical requirements products may contain dangerous substances. For information on the types in question please contact your nearest Infineon Technologies office.

Except as otherwise explicitly approved by Infineon Technologies in a written document signed by authorized representatives of Infineon Technologies, Infineon Technologies' products may not be used in any applications where a failure of the product or any consequences of the use thereof can reasonably be expected to result in personal injury.