

Ambient Light Sensor IC Series

# Digital 16bit Serial Output Type Ambient Light Sensor IC

## BH1730FVC

### General Description

BH1730FVC is a digital Ambient Light Sensor IC with I<sup>2</sup>C bus interface. This IC is most suitable for obtaining ambient light data for adjusting LCD and backlight power of TV and mobile phone. It is capable of detecting a very wide range of illuminance.

### Features

- I<sup>2</sup>C bus Interface  
f/s Mode Support, Slave Address "0101001"
- 2 outputs with peak wavelengths of visible light and infrared light respectively.
- Illuminance to digital converter
- Low current by power down function
- 50Hz / 60Hz light noise reject function
- Light source dependency is small by the calculation using 2 outputs. (e.g. Incandescent lamp, Fluorescent lamp, Halogen lamp, White LED and Sun light)
- Built-in interrupt function
- Sensitivity adjustment function for compensation for illuminance decrease by optical window

### Key Specifications

- Supply Voltage Range: 2.4V to 3.6V
- I<sup>2</sup>C I/O Voltage: 1.65V to V<sub>CC</sub> V
- Detection Range: 0.001 lx to 100k lx
- Current Consumption: 150 μA (Typ)
- Power Down Current: 0.85 μA (Typ)
- Operating Temperature Range: -40°C to +85°C

### Package

WSOF6

W(Typ) x D(Typ) x H(Max)

1.60mm x 3.00mm x 0.75mm

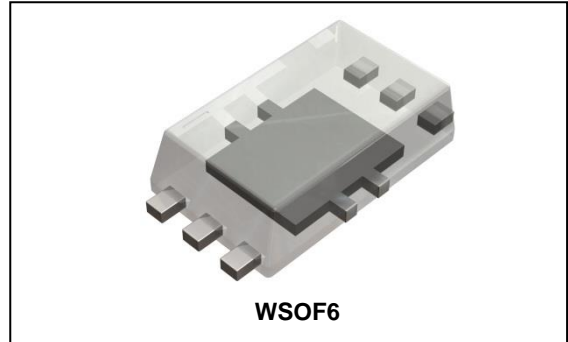

### Applications

LCD TV, Mobile Phone, Tablet PC, Note PC,  
Digital Camera, Portable Game Machine

### Typical Application Circuit

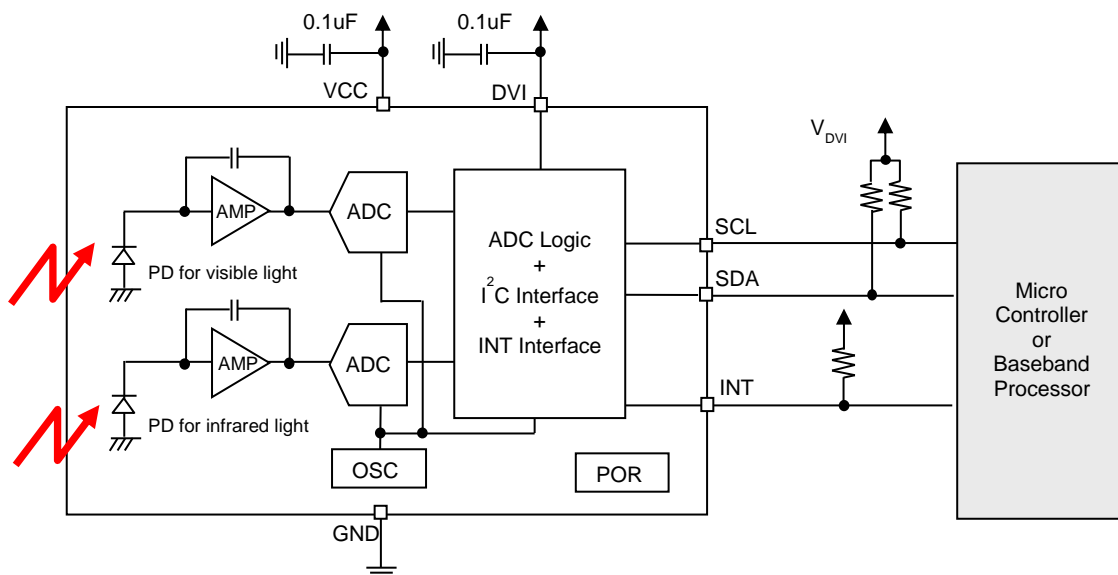

○Product structure : Silicon monolithic integrated circuit.  
○This product does not include laser transmitter.  
○This product includes Photo detector, ( Photo Diode ) inside of it.

○This product has no designed protection against radioactive rays.  
○This product does not include optical load.

## Pin Configuration

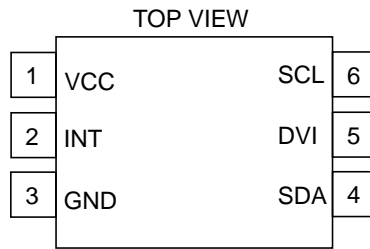

## Pin Description

Pin No.	Pin Name	Function
1	VCC	Power supply terminal
2	INT	INT pin output terminal. If not in use, connect to GND or leave it open.
3	GND	GND terminal
4	SDA	I <sup>2</sup> C bus interface SDA terminal
5	DVI	I <sup>2</sup> C bus I/O voltage
6	SCL	I <sup>2</sup> C bus interface SCL terminal

## Block Diagram

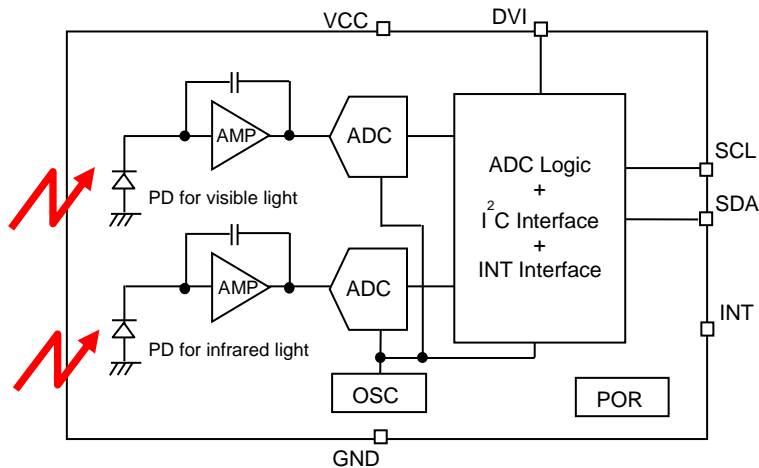

## Description of Blocks

1. PD  
Photo diodes (PD) with peak wavelengths of visible light and infrared light respectively.
2. AMP  
Integrating AMP for converting PD current to voltage.
3. ADC  
Analog-to-Digital Converter for obtaining 16bit digital data.
4. ADC Logic + I<sup>2</sup>C Interface + INT Interface  
ADC control logic and I/F logic interface.
5. OSC  
Oscillator for clock of internal logic.
6. POR  
Power ON Reset. Please refer to "Power ON Sequence" on P14.

**Absolute Maximum Ratings** (Ta=25°C)

Parameter	Symbol	Rating	Unit
Supply Voltage	V <sub>CCMAX</sub>	4.5	V
INT, SDA, DVI, SCL Terminal Voltage	V <sub>INTMAX</sub> , V <sub>SDAMAX</sub> , V <sub>DVIMAX</sub> , V <sub>SCLMAX</sub>	-0.3 to +7	V
Operating Temperature	T <sub>opr</sub>	-40 to +85	°C
Storage Temperature	T <sub>stg</sub>	-40 to +100	°C
SDA, INT Sink Current	I <sub>MAX</sub>	7	mA
Power Dissipation	P <sub>d</sub>	0.26 <sup>(Note 1)</sup>	W

(Note 1) 70mm x 70mm x 1.6mm glass epoxy board. Derating is at 3.47mW/°C for operating above Ta=25°C.

**Caution:** Operating the IC over the absolute maximum ratings may damage the IC. The damage can either be a short circuit between pins or an open circuit between pins. Therefore, it is important to consider circuit protection measures, such as adding a fuse, in case the IC is operated over the absolute maximum ratings.

**Recommended Operating Conditions** (Ta=-40°C to +85°C)

Parameter	Symbol	Min	Typ	Max	Unit
Supply Voltage	V <sub>CC</sub>	2.4	3.0	3.6	V
I <sup>2</sup> C I/O Voltage	V <sub>DVI</sub>	1.65	-	V <sub>CC</sub>	V

**Electrical Characteristics** ( $V_{CC} = 3.0V$ ,  $V_{DVI} = 3.0V$ ,  $T_a = 25^\circ C$ , unless otherwise noted)

Parameter	Symbol	Min	Typ	Max	Unit	Conditions
Supply Current	$I_{CC1}$	-	150	200	$\mu A$	$E_V = 100 \text{ lx}$ <sup>(Note 1)</sup> CONTROL register(00h) = "03h" and the other registers are default.
Power Down Current	$I_{CC2}$	-	0.85	1.5	$\mu A$	No input Light All registers are default.
Peak Wave Length of Type0 <sup>(Note 2)</sup>	$\lambda_{p0}$	-	600	-	nm	
Peak Wave Length of Type1 <sup>(Note 2)</sup>	$\lambda_{p1}$	-	840	-	nm	
ADC Count Value of Type0	D1k_0	1020	1200	1380	count	$E_V = 1000 \text{ lx}$ <sup>(Note 1)</sup> TIMING register(01h) = "DAh" GAIN register(07h) = "00h"
ADC Count Value of Type1	D1k_1	153	180	207	count	$E_V = 1000 \text{ lx}$ <sup>(Note 1)</sup> TIMING register(01h) = "DAh" GAIN register(07h) = "00h"
Dark (0 lx) Sensor Out of Type0	S0_0	0	0	2	count	No input Light TIMING register(01h) = "DAh" GAIN register(07h) = "00h"
Dark (0 lx) Sensor Out of Type1	S0_1	0	0	2	count	No input Light TIMING register(01h) = "DAh" GAIN register(07h) = "00h"
Gain x1 Resolution of Type0 <sup>(Note 2)</sup>	$r_{G1}$	-	0.83	-	lx/count	TIMING register(01h) = "DAh" <sup>(Note 1)</sup>
Gain x2 Resolution of Type0 <sup>(Note 2)</sup>	$r_{G2}$	-	0.42	-	lx/count	TIMING register(01h) = "DAh" <sup>(Note 1)</sup>
Gain x64 Resolution of Type0 <sup>(Note 2)</sup>	$r_{G64}$	-	0.014	-	lx/count	TIMING register(01h) = "DAh" <sup>(Note 1)</sup>
Gain x128 Resolution of Type0 <sup>(Note 2)</sup>	$r_{G128}$	-	0.007	-	lx/count	TIMING register(01h) = "DAh" <sup>(Note 1)</sup>
Measurement Time	Tmt1	-	104.6	150	ms	TIMING register(01h) = "DAh"
Internal Clock Period	Tint	-	2.8	4.0	$\mu s$	
INT Output 'L' Voltage	$V_{INT}$	0	-	0.4	V	$I_{INT} = 3 \text{ mA}$
SCL, SDA Input 'H' Voltage 1	$V_{IH1}$	$0.7 \cdot V_{DVI}$	-	-	V	$V_{DVI} \geq 1.8V$
SCL, SDA Input 'H' Voltage 2	$V_{IH2}$	1.26	-	-	V	$1.65V \leq V_{DVI} < 1.8V$
SCL, SDA Input 'L' Voltage 1	$V_{IL1}$	-	-	$0.3 \cdot V_{DVI}$	V	$V_{DVI} \geq 1.8V$
SCL, SDA Input 'L' Voltage 2	$V_{IL2}$	-	-	$V_{DVI} - 1.26$	V	$1.65V \leq V_{DVI} < 1.8V$
SCL, SDA, INT Input 'H' Current	$I_{IH}$	-	-	10	$\mu A$	
SCL, SDA, INT Input 'L' Current	$I_{IL}$	-	-	10	$\mu A$	
I <sup>2</sup> C SCL Clock Frequency	$f_{SCL}$	-	-	400	kHz	
I <sup>2</sup> C Bus Free Time	$t_{BUF}$	1.3	-	-	$\mu s$	
I <sup>2</sup> C Hold Time (Repeated) START Condition	$t_{HDSTA}$	0.6	-	-	$\mu s$	
I <sup>2</sup> C Setup Time for a Repeated START Condition	$t_{SUSTA}$	0.6	-	-	$\mu s$	
I <sup>2</sup> C Setup Time for STOP Condition	$t_{SUSTO}$	0.6	-	-	$\mu s$	
I <sup>2</sup> C Data Hold Time	$t_{HDDAT}$	0	-	0.9	$\mu s$	
I <sup>2</sup> C Data Setup Time	$t_{SDAT}$	100	-	-	ns	
I <sup>2</sup> C 'L' Period of the SCL Clock	$t_{LOW}$	1.3	-	-	$\mu s$	
I <sup>2</sup> C 'H' Period of the SCL Clock	$t_{HIGH}$	0.6	-	-	$\mu s$	
I <sup>2</sup> C SDA Output 'L' Voltage	$V_{OL}$	0	-	0.4	V	$I_{OL} = 3 \text{ mA}$

(Note 1) White LED is used as optical source.

(Note 2) Not 100% Tested

Typical Performance Curves

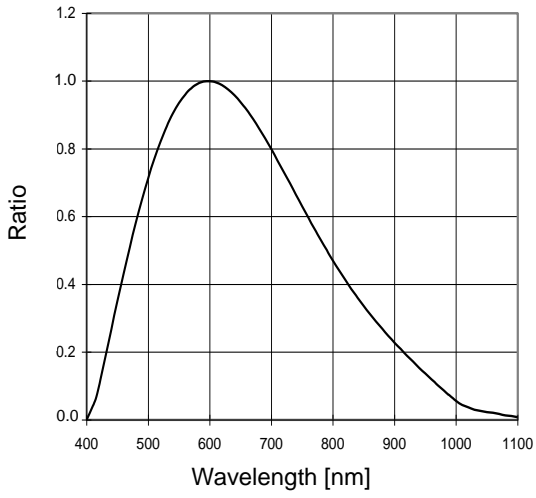

Figure 1. Ratio vs Wavelength  
(Spectral Response of Type0, Visible Light Peak)

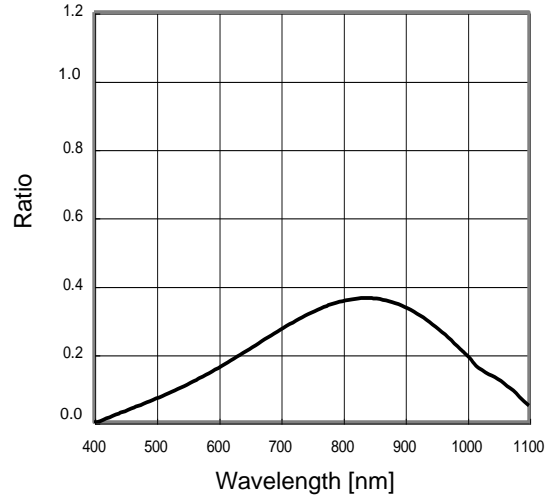

Figure 2. Ratio vs Wavelength  
(Spectral Response of Type1, Infrared Light Peak)

Application Information

1. I<sup>2</sup>C Bus Access and Write / Read Format

(1) I<sup>2</sup>C Bus Interface Timing Chart

Write measurement command and Read measurement results are done by I<sup>2</sup>C Bus interface. Please refer to the formal specification of I<sup>2</sup>C Bus interface, and follow the formal timing chart.

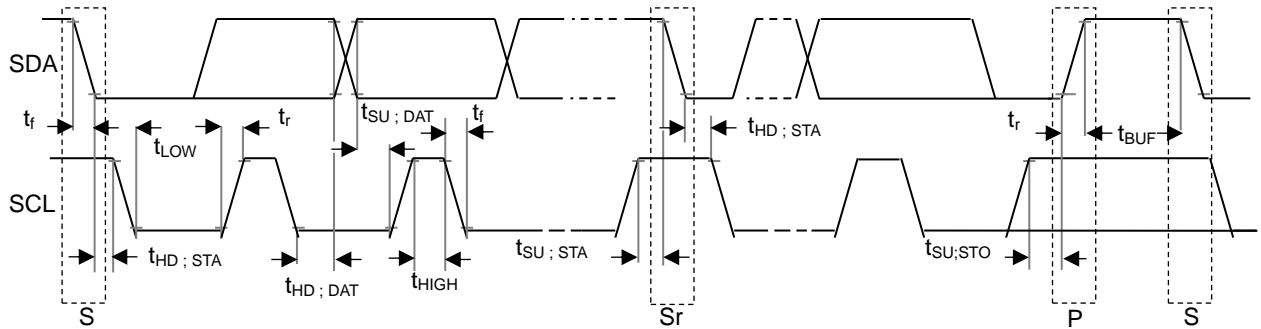

(2) Main Write Format

(a) Write to Command Register

ST	Slave Address 0101001	W 0	ACK	Data to Command Register 1XXXXXXX	ACK	SP
----	--------------------------	--------	-----	--------------------------------------	-----	----

(b) Write to Data Register

ST	Slave Address 0101001	W 0	ACK	Data specified at register address field 0XXXXXXX	ACK
----	--------------------------	--------	-----	--	-----

Data specified at register address field +1	ACK	...	ACK	Data specified at register address field +N	ACK	SP
---	-----	-----	-----	---	-----	----

Note: The register address that is set in the command register is used.

(c) Write to Data Register After Write to Command Register

ST	Slave Address 0101001	W 0	ACK	Data to Command Register 1XXXXXXX	ACK
----	--------------------------	--------	-----	--------------------------------------	-----

Data specified at register address field	ACK	...	ACK	Data specified at register address field +N	ACK	SP
--	-----	-----	-----	---	-----	----

(3) Main Read Format

ST	Slave Address 0101001	R 1	ACK	Data specified at register address field	ACK
----	--------------------------	--------	-----	--	-----

Data specified at register address field +1	ACK	...	ACK	Data specified at register address field +N	NACK	SP
---	-----	-----	-----	---	------	----

Note: The register address that is set in the command register is used.



from Master to Slave



from Slave to Master

Note: BH1730FVC operates as I<sup>2</sup>C bus slave device.  
Note: Please refer to I<sup>2</sup>C bus specification of NXP semiconductor

BH1730FVC continues to write or read data with address increments until master issues stop condition

Address cycle: 00h -> 01h -> 02h -> 03h -> 04h -> 05h -> 06h -> 07h -> 12h -> 14h -> 15h -> 16h -> 17h

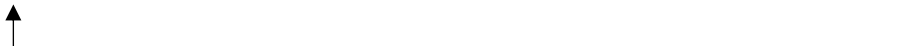

2. Measurement Procedure

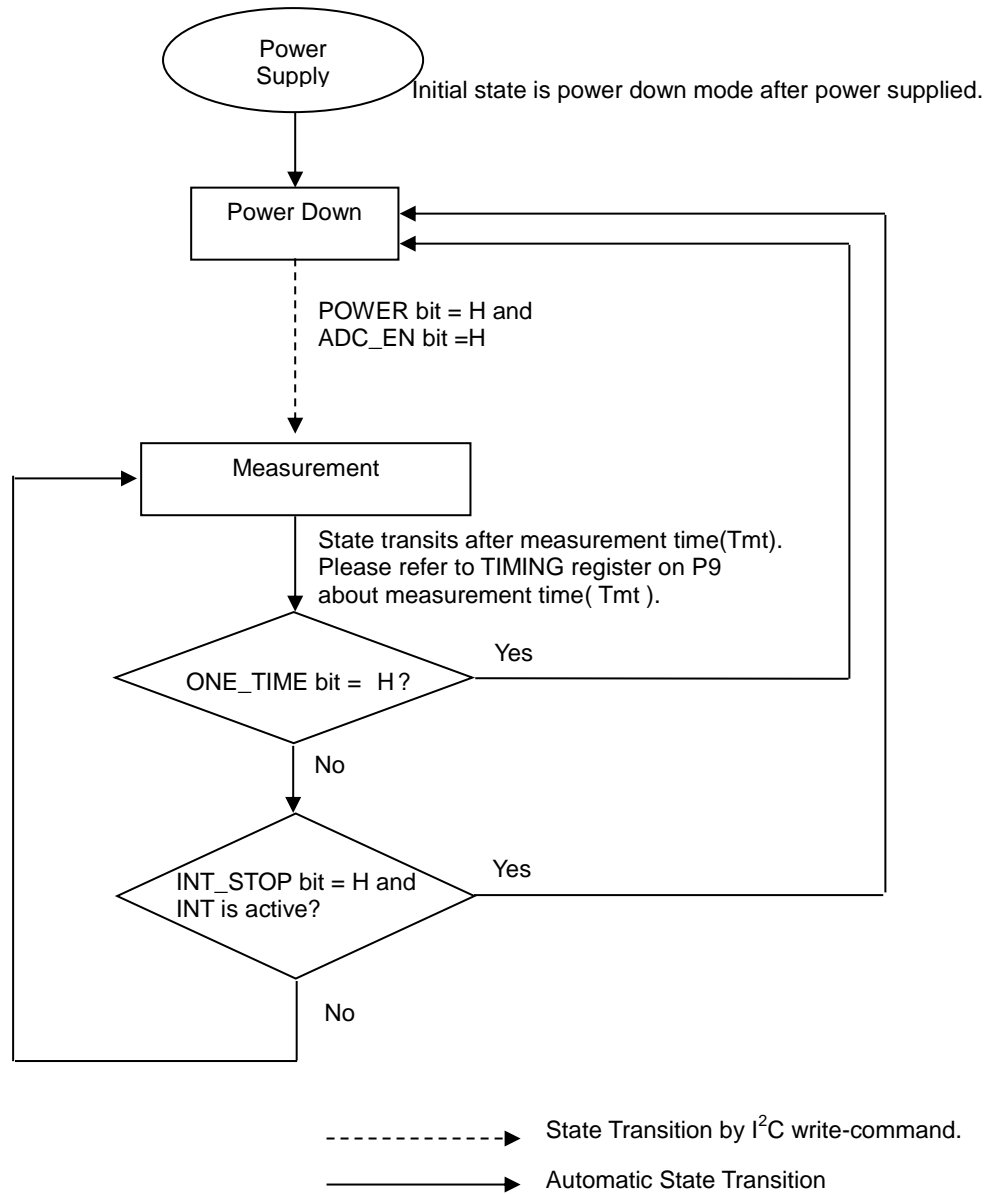

3. Software Reset Command.

All registers are reset and BH1730FVC becomes power down state by software reset command.

## 4. Command Set

Address [4:0]	Type	Register name	Register function
--	W	COMMAND	Specifies register address or sets special command
00h	RW	CONTROL	Operation mode control
01h	RW	TIMING	Light integration time control
02h	RW	INTERRUPT	Interrupt function control
03h	RW	THLLOW	Low byte of low interrupt threshold setting
04h	RW	THLHIGH	High byte of low interrupt threshold setting
05h	RW	THHLOW	Low byte of high interrupt threshold setting
06h	RW	THHHIGH	High byte of high interrupt threshold setting
07h	RW	GAIN	Gain control
12h	R	ID	Part number and Revision ID
14h	R	DATA0LOW	ADC Type0 low byte data register
15h	R	DATA0HIGH	ADC Type0 high byte data register
16h	R	DATA1LOW	ADC Type1 low byte data register
17h	R	DATA1HIGH	ADC Type1 high byte data register

(Note) Do not send command to the register which is not defined above.

## (1)COMMAND

7	6	5	4	3	2	1	0
CMD	TRANSACTION		ADDRESS / Special command				

default value 00h

Field	Bit	Type	Description
CMD	7	W	Write 1
TRANSACTION	6 : 5	W	00 : COMMAND<4:0> is ADDRESS field. 01 : Reserved. 10 : Reserved. 11 : COMMAND<4:0> is Special command field.
ADDRESS	4 : 0	W	Specify register address. Don't specify invalid register address.
Special command			00001 : Interrupt output reset. 00010 : Stop measurement in manual integration mode. 00011 : Start measurement in manual integration mode. 00100 : Software reset Don't input other commands.

## (2) CONTROL (00h)

7	6	5	4	3	2	1	0
RES		ADC_ INTR	ADC_ VALID	ONE_ TIME	DATA_ SEL	ADC_ EN	POWER

default value 00h

Field	Bit	Type	Description
RES	7: 6	RW	Write 00
ADC_INTR	5	R	0 : Interrupt is inactive. 1 : Interrupt is active.
ADC_VALID	4	R	0 : ADC data is not updated after last reading. 1 : ADC data is updated after last reading.
ONE_TIME	3	RW	0 : ADC measurement is continuous. 1 : ADC measurement is one time. ADC transits to power down automatically.
DATA_SEL	2	RW	0 : ADC measurement Type0 and Type1. 1 : ADC measurement Type0 only.
ADC_EN	1	RW	0 : ADC measurement stops. 1 : ADC measurement starts.
POWER	0	RW	0 : ADC power down. 1 : ADC power on.

## (3) TIMING (01h)

7	6	5	4	3	2	1	0
ITIME							

default value DAh

Field	Bit	Type	Description
ITIME	7 : 0	RW	00h : Start / Stop of measurement is set by special command. (ADC manual integration mode) 01h to FFh : Integration time is determined by ITIME value  Integration Time : $ITIME\_ms = Tint * 964 * (256 - ITIME)$ Measurement time : $Tmt = ITIME\_ms + Tint * 714$

## (4) INTERRUPT (02h)

7	6	5	4	3	2	1	0
RES	INT_STOP	RES	INT_EN	PERSIST			

default value 00h

Field	Bit	Type	Description
RES	7	RW	Write 0
INT_STOP	6	RW	0 : ADC measurement does not stop. 1 : ADC measurement stops and transits to power down mode when interrupt becomes active.
RES	5	RW	Write 0
INT_EN	4	RW	0 : Disable interrupt function. 1 : Enable interrupt function.
PERSIST	3 : 0	RW	Interrupt persistence function. 0000 : Interrupt becomes active at each measurement end. 0001 : Interrupt status is updated at each measurement end. 0010 : Interrupt status is updated if two consecutive threshold judgments are the same. When set 0011 or more, interrupt status is updated if same threshold judgments continue consecutively same times as the number set in "PERSIST".

## (5) TH\_LOW (03h,04h)

Register	Address	Bit	Type	Description
TH lower LSBs	03h	7 : 0	RW	Lower byte of low interrupt threshold
TH lower MSBs	04h	7 : 0	RW	Upper byte of low interrupt threshold

default value 00h

## (6) TH\_UP (05h,06h)

Register	Address	Bit	Type	Description
TH upper LSBs	05h	7 : 0	RW	Lower byte of high interrupt threshold
TH upper MSBs	06h	7 : 0	RW	Upper byte of high interrupt threshold

default value FFh

## (7) GAIN (07h)

7	6	5	4	3	2	1	0
RES				GAIN			

default value 00h

Field	Bit	Type	Description
RES	7 : 3	RW	Write 00000
GAIN	2 : 0	RW	ADC resolution setting X00 : x1 gain mode X01 : x2 gain mode X10 : x64 gain mode X11 : x128 gain mode

## (8) PART\_ID ( 12h )

7	6	5	4	3	2	1	0
Part Number				Revision ID			

default value 7Xh

Field	Bit	Type	Description
Part number	7 : 4	R	0111
Revision ID	3 : 0	R	Don't use Revision ID Data

## (9) DATA0 (14h,15h)

Register	Address	Bit	Type	Description
DATA0 LSBs	14h	7 : 0	R	Lower byte of ADC Type0 data
DATA0 MSBs	15h	7 : 0	R	Upper byte of ADC Type0 data

default value 00h

## (10) DATA1 (16h,17h)

Register	Address	Bit	Type	Description
DATA1 LSBs	16h	7 : 0	R	Lower byte of ADC Type1 data
DATA1 MSBs	17h	7 : 0	R	Upper byte of ADC Type1 data

default value 00h

5. Measurement Sequence Example from "Write start measurement command" to "Read measurement result"



from Master to Slave



from Slave to Master

(1) Send "Continuous measurement mode" command.

ST	Slave Address 0101001	W 0	ACK	Write Command Register 1000_0000	ACK
----	--------------------------	--------	-----	-------------------------------------	-----

Write CONTROL register 0000_0011	ACK	SP
-------------------------------------	-----	----

(2) Wait measurement completion.

(3) Read measurement result.

ST	Slave Address 0101001	W 0	ACK	Write Command Register 1001_0100	ACK	SP
----	--------------------------	--------	-----	-------------------------------------	-----	----

ST	Slave Address 0101001	R 1	ACK	Read DATA0 LSBs register	ACK
----	--------------------------	--------	-----	--------------------------	-----

Read DATA0 MSBs register	ACK	Read DATA1 LSBs register	ACK
--------------------------	-----	--------------------------	-----

Read DATA1 MSBs register	NACK	SP
--------------------------	------	----

**6. Lux Calculation using DATA0 and DATA1**

BH1730FVC has two outputs, DATA0 (14h, 15h) for detecting mainly visible light, and DATA1 (16h, 17h) for detecting mainly infrared light. Lux value can be calculated by using these two outputs. The calculation formula depends on the characteristic of optical window. The example of the calculation is shown as below.

Ex) No optical window or optical window that has flat transmittance from visible light to infrared light.

```

if (DATA1/DATA0<0.26) Lx = ( 1.290 x DATA0 - 2.733 x DATA1 ) / Gain x 102.6 / ITIME_ms
else if (DATA1/DATA0<0.55) Lx = ( 0.795 x DATA0 - 0.859 x DATA1 ) / Gain x 102.6 / ITIME_ms
else if (DATA1/DATA0<1.09) Lx = ( 0.510 x DATA0 - 0.345 x DATA1 ) / Gain x 102.6 / ITIME_ms
else if (DATA1/DATA0<2.13) Lx = ( 0.276 x DATA0 - 0.130 x DATA1 ) / Gain x 102.6 / ITIME_ms
else Lx=0
    
```

ITIME\_ms : Integration time of measurement (unit: ms). Please refer to TIMING register on P9.

**7. Interrupt Function**

Interrupt function compares measurement result to preset interrupt threshold level. BH1730FVC uses two threshold levels (upper and lower). If measurement result is outside of the two thresholds, INT pin outputs 'L'. Interrupt threshold is set in Interrupt threshold registers (03h - 06h).

Interrupt function is controlled by the Interrupt operational code. Interrupt persistence is set by PERSIST bit in INTERRUPT register(02h<3:0>).

INT pin is an Nch open drain terminal. Hence this terminal has to have an external pull-up resistor to a voltage source.

Maximum sink current rating of this terminal is 7mA.

INT terminal state is high impedance when VCC is supplied.

INT terminal becomes inactive by setting "Interrupt output reset" of special command. VCC current is consumed when INT terminal is 'L'. So it is recommended to reset INT terminal immediately when interrupt is detected.

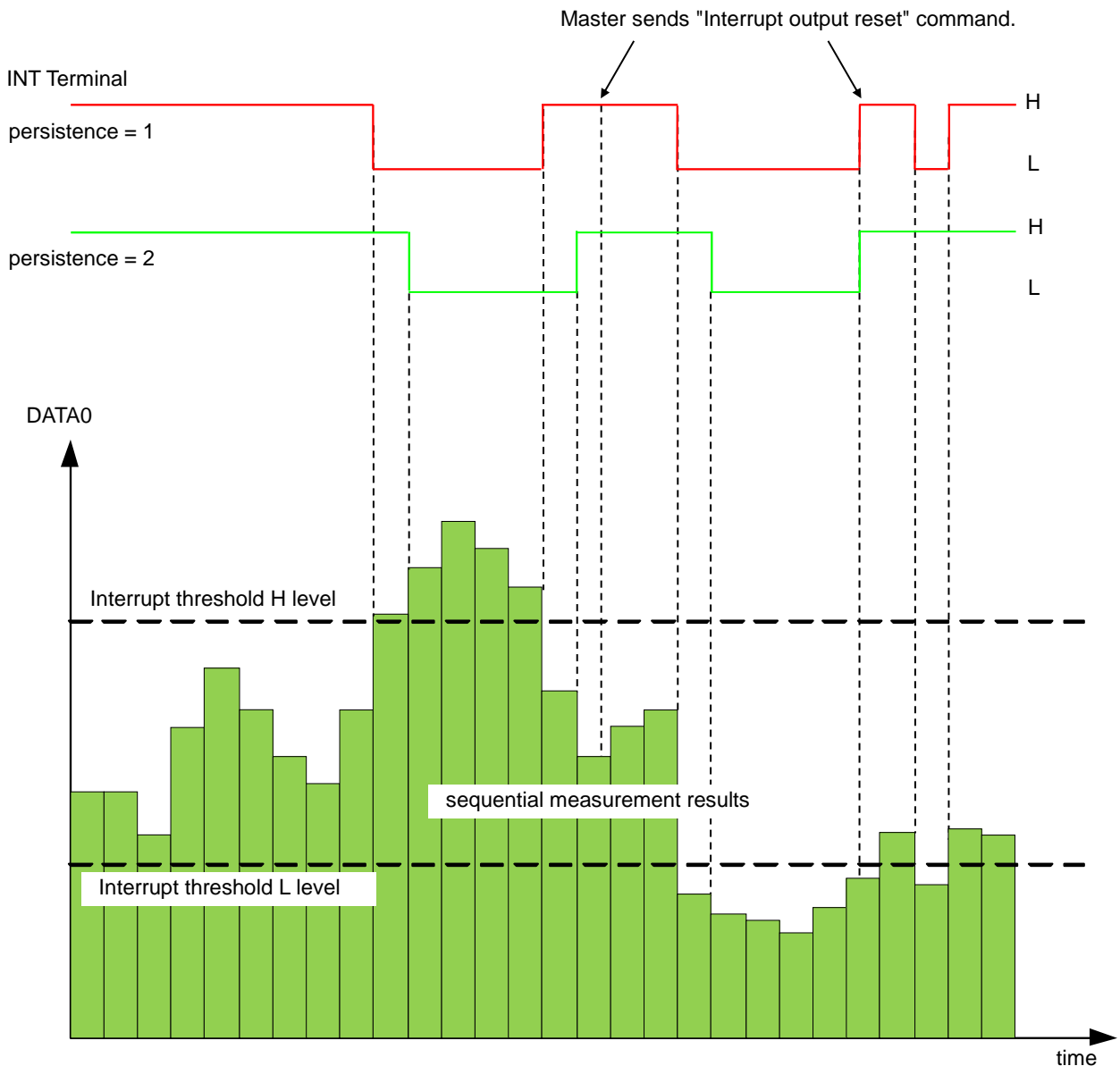

**8. Power On Sequence**

ALL registers of BH1730FVC are reset when VCC powers up. There are some notes about power up and down sequence as shown below.

(1) Power ON Time:  $t_1$

More than 2ms is needed to activate BH1730FVC after VCC becomes more than 2.4V from less than 0.4V. Operating voltage is from 2.4V to 3.6V.

(2) Power OFF time:  $t_2$

More than 1ms ( $VCC < 0.4V$ ) is needed before supplying power to BH1730FVC.

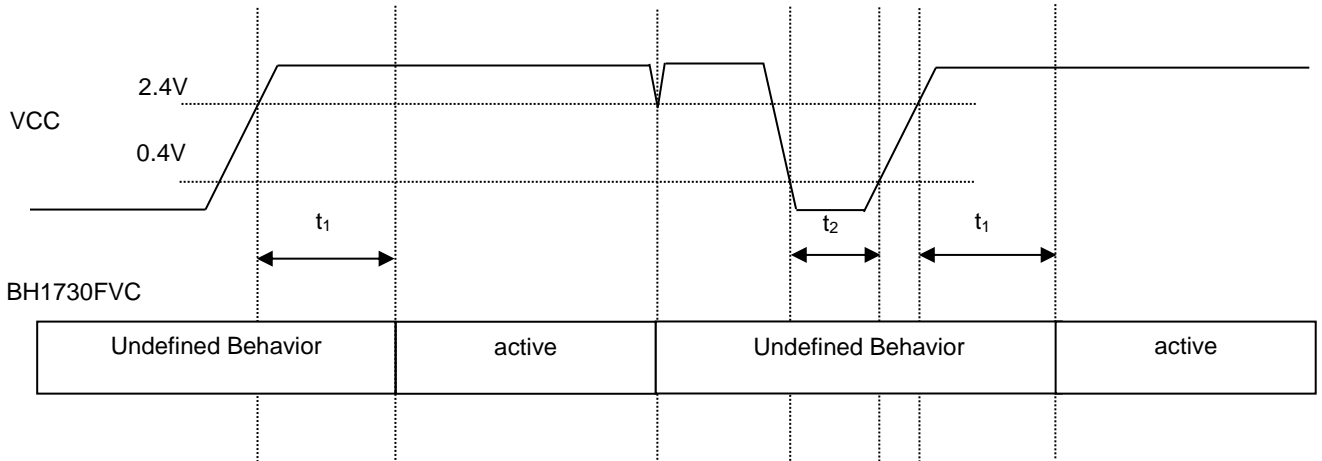

Note: "active state" means that BH1730FVC operates and accept I<sup>2</sup>C bus access correctly.

**9. ALS Sensitivity Adjustment Function**

BH1730FVC is capable of changing its ALS sensitivity. This is used to compensate the effect of attenuation by the optical window. Adjustment is done by changing the integration time. For example, when transmission rate of optical window is 1/n (measurement result becomes 1/n times if optical window is above the sensor), the effect of optical window is compensated by changing integration time from default to n times.

Take note that at 100,000 lx or higher illuminance cannot be measured even when the sensitivity is decreased.

**10. Optical Design for the Device**

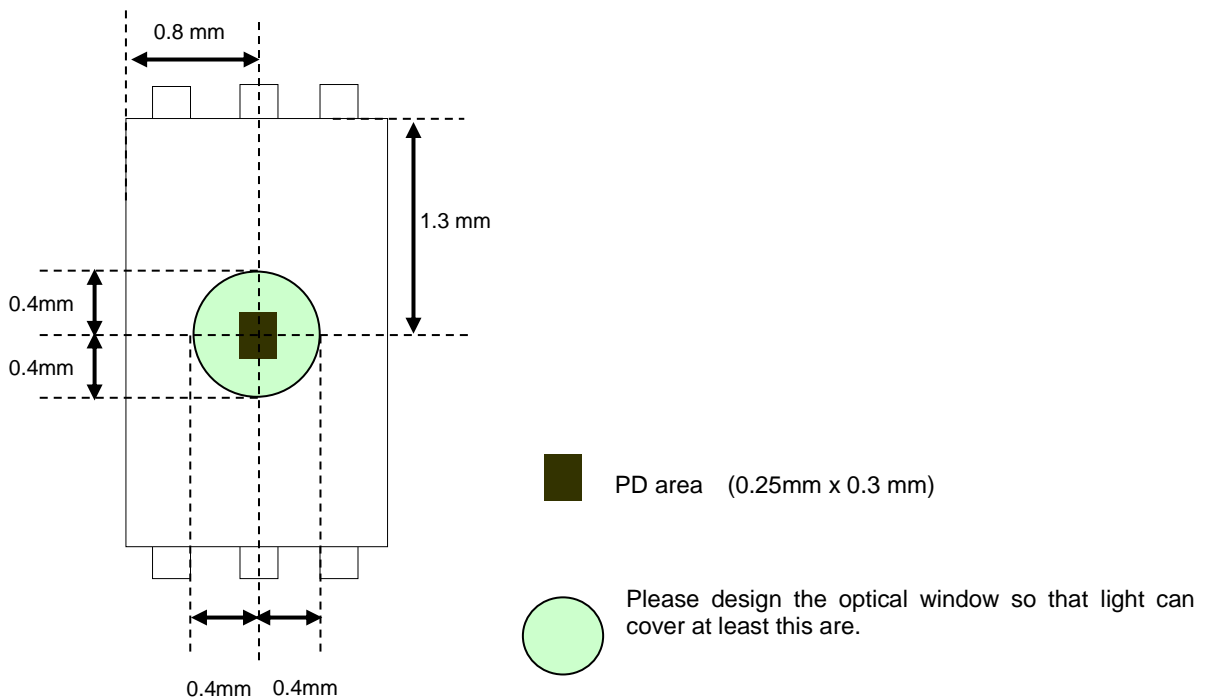

I/O Equivalent Circuit

PIN No.	Terminal Name	Equivalent Circuit
1	VCC	
2	INT	
3	GND	
4	SDA	
5	DVI	
6	SCL	

(Note) These values are typical value.

## Operational Notes

- 1. Reverse Connection of Power Supply**

Connecting the power supply in reverse polarity can damage the IC. Take precautions against reverse polarity when connecting the power supply, such as mounting an external diode between the power supply and the IC's power supply pins.
- 2. Power Supply Lines**

Design the PCB layout pattern to provide low impedance supply lines. Furthermore, connect a capacitor to ground at all power supply pins. Consider the effect of temperature and aging on the capacitance value when using electrolytic capacitors.
- 3. Ground Voltage**

Ensure that no pins are at a voltage below that of the ground pin at any time, even during transient condition.
- 4. Ground Wiring Pattern**

When using both small-signal and large-current ground traces, the two ground traces should be routed separately but connected to a single ground at the reference point of the application board to avoid fluctuations in the small-signal ground caused by large currents. Also ensure that the ground traces of external components do not cause variations on the ground voltage. The ground lines must be as short and thick as possible to reduce line impedance.
- 5. Thermal Consideration**

Should by any chance the power dissipation rating be exceeded the rise in temperature of the chip may result in deterioration of the properties of the chip. In case of exceeding this absolute maximum rating, increase the board size and copper area to prevent exceeding the Pd rating.
- 6. Recommended Operating Conditions**

These conditions represent a range within which the expected characteristics of the IC can be approximately obtained. The electrical characteristics are guaranteed under the conditions of each parameter.
- 7. Inrush Current**

When power is first supplied to the IC, it is possible that the internal logic may be unstable and inrush current may flow instantaneously due to the internal powering sequence and delays, especially if the IC has more than one power supply. Therefore, give special consideration to power coupling capacitance, power wiring, width of ground wiring, and routing of connections.
- 8. Operation Under Strong Electromagnetic Field**

Operating the IC in the presence of a strong electromagnetic field may cause the IC to malfunction.
- 9. Testing on Application Boards**

When testing the IC on an application board, connecting a capacitor directly to a low-impedance output pin may subject the IC to stress. Always discharge capacitors completely after each process or step. The IC's power supply should always be turned off completely before connecting or removing it from the test setup during the inspection process. To prevent damage from static discharge, ground the IC during assembly and use similar precautions during transport and storage.
- 10. Inter-pin Short and Mounting Errors**

Ensure that the direction and position are correct when mounting the IC on the PCB. Incorrect mounting may result in damaging the IC. Avoid nearby pins being shorted to each other especially to ground, power supply and output pin. Inter-pin shorts could be due to many reasons such as metal particles, water droplets (in very humid environment) and unintentional solder bridge deposited in between pins during assembly to name a few.
- 11. Unused Input Pins**

Input pins of an IC are often connected to the gate of a MOS transistor. The gate has extremely high impedance and extremely low capacitance. If left unconnected, the electric field from the outside can easily charge it. The small charge acquired in this way is enough to produce a significant effect on the conduction through the transistor and cause unexpected operation of the IC. So unless otherwise specified, unused input pins should be connected to the power supply or ground line.

## Operational Notes – continued

## 12. Regarding the Input Pin of the IC

This monolithic IC contains P+ isolation and P substrate layers between adjacent elements in order to keep them isolated. P-N junctions are formed at the intersection of the P layers with the N layers of other elements, creating a parasitic diode or transistor. For example (refer to figure below):

When  $GND > Pin A$  and  $GND > Pin B$ , the P-N junction operates as a parasitic diode.

When  $GND > Pin B$ , the P-N junction operates as a parasitic transistor.

Parasitic diodes inevitably occur in the structure of the IC. The operation of parasitic diodes can result in mutual interference among circuits, operational faults, or physical damage. Therefore, conditions that cause these diodes to operate, such as applying a voltage lower than the GND voltage to an input pin (and thus to the P substrate) should be avoided.

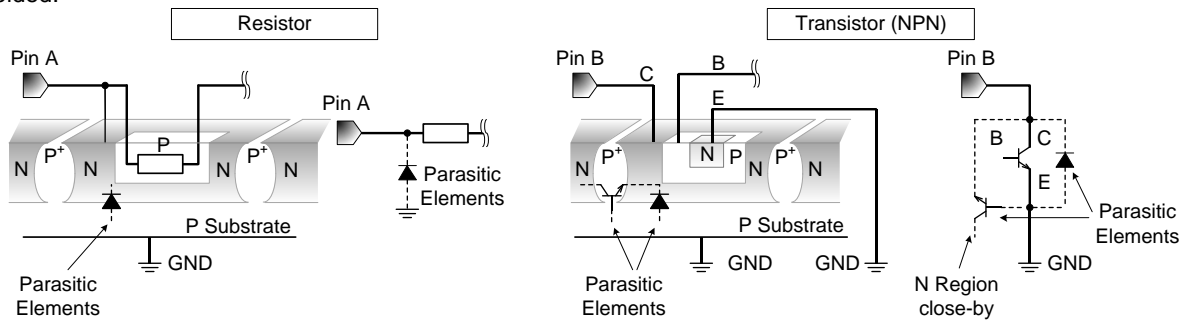

Figure 3. Example of monolithic IC structure

## 13. Ceramic Capacitor

When using a ceramic capacitor, determine the dielectric constant considering the change of capacitance with temperature and the decrease in nominal capacitance due to DC bias and others.

## 14. Area of Safe Operation (ASO)

Operate the IC such that the output voltage, output current, and power dissipation are all within the Area of Safe Operation (ASO).

Ordering Information

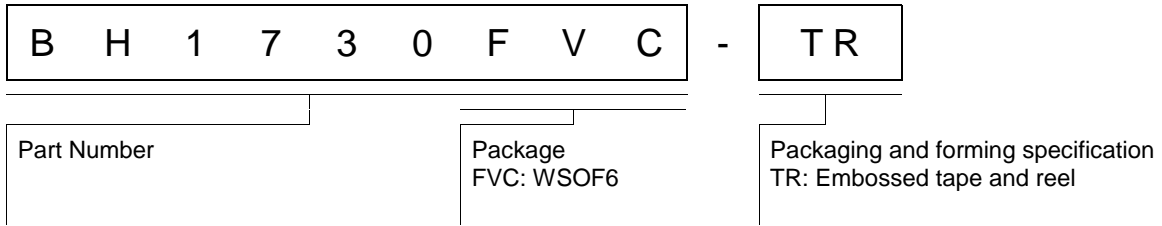

Marking Diagram and Methods of Distinguishing 1pin

There are some methods to distinguish 1pin.

- ① Distinguishing by 1Pin marking
- ② Distinguishing by die pattern
- ③ Distinguishing by taper part of 1-3pin side

②(by die pattern) is the easiest method to distinguish by naked eye.

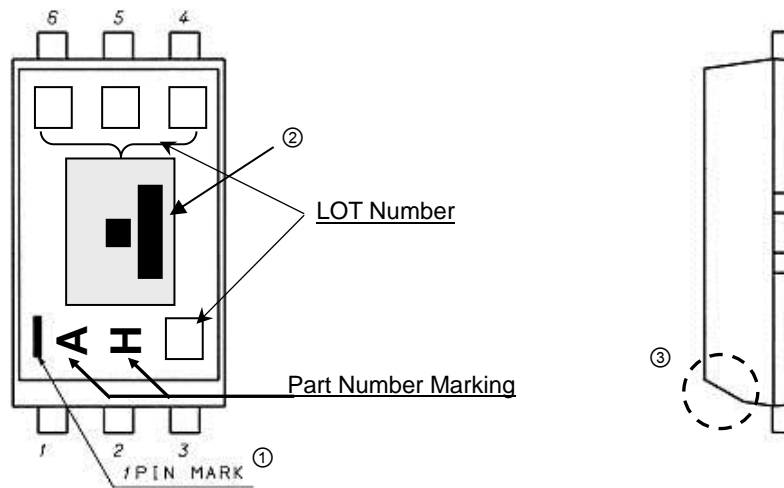

Physical Dimension, Tape and Reel Information

Package Name	WSOF6
--------------	-------

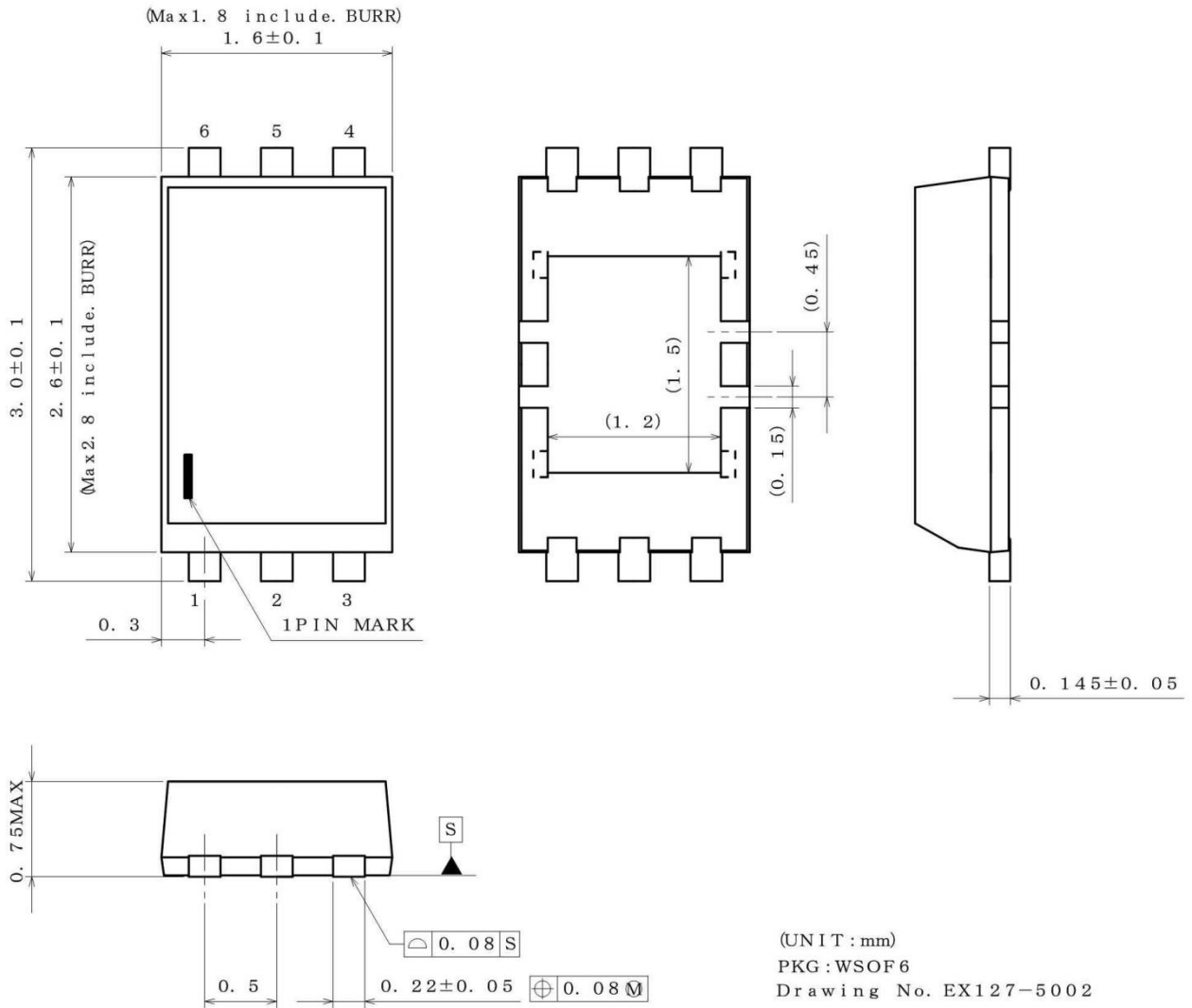

**<Tape and Reel information>**

Tape	Embossed carrier tape
Quantity	3000pcs
Direction of feed	TR (The direction is the 1pin of product is at the upper right when you hold reel on the left hand and you pull out the tape on the right hand)

\*Order quantity needs to be multiple of the minimum quantity.

**Revision History**

Date	Revision	Changes
8. Jun. 2016	001	New release

# Notice

## Precaution on using ROHM Products

- Our Products are designed and manufactured for application in ordinary electronic equipments (such as AV equipment, OA equipment, telecommunication equipment, home electronic appliances, amusement equipment, etc.). If you intend to use our Products in devices requiring extremely high reliability (such as medical equipment <sup>(Note 1)</sup>, transport equipment, traffic equipment, aircraft/spacecraft, nuclear power controllers, fuel controllers, car equipment including car accessories, safety devices, etc.) and whose malfunction or failure may cause loss of human life, bodily injury or serious damage to property ("Specific Applications"), please consult with the ROHM sales representative in advance. Unless otherwise agreed in writing by ROHM in advance, ROHM shall not be in any way responsible or liable for any damages, expenses or losses incurred by you or third parties arising from the use of any ROHM's Products for Specific Applications.

(Note1) Medical Equipment Classification of the Specific Applications

JAPAN	USA	EU	CHINA
CLASS III	CLASS III	CLASS II b	CLASS III
CLASS IV		CLASS III	

- ROHM designs and manufactures its Products subject to strict quality control system. However, semiconductor products can fail or malfunction at a certain rate. Please be sure to implement, at your own responsibilities, adequate safety measures including but not limited to fail-safe design against the physical injury, damage to any property, which a failure or malfunction of our Products may cause. The following are examples of safety measures:
  - Installation of protection circuits or other protective devices to improve system safety
  - Installation of redundant circuits to reduce the impact of single or multiple circuit failure
- Our Products are designed and manufactured for use under standard conditions and not under any special or extraordinary environments or conditions, as exemplified below. Accordingly, ROHM shall not be in any way responsible or liable for any damages, expenses or losses arising from the use of any ROHM's Products under any special or extraordinary environments or conditions. If you intend to use our Products under any special or extraordinary environments or conditions (as exemplified below), your independent verification and confirmation of product performance, reliability, etc. prior to use, must be necessary:
  - Use of our Products in any types of liquid, including water, oils, chemicals, and organic solvents
  - Use of our Products outdoors or in places where the Products are exposed to direct sunlight or dust
  - Use of our Products in places where the Products are exposed to sea wind or corrosive gases, including Cl<sub>2</sub>, H<sub>2</sub>S, NH<sub>3</sub>, SO<sub>2</sub>, and NO<sub>2</sub>
  - Use of our Products in places where the Products are exposed to static electricity or electromagnetic waves
  - Use of our Products in proximity to heat-producing components, plastic cords, or other flammable items
  - Sealing or coating our Products with resin or other coating materials
  - Use of our Products without cleaning residue of flux (even if you use no-clean type fluxes, cleaning residue of flux is recommended); or Washing our Products by using water or water-soluble cleaning agents for cleaning residue after soldering
  - Use of the Products in places subject to dew condensation
- The Products are not subject to radiation-proof design.
- Please verify and confirm characteristics of the final or mounted products in using the Products.
- In particular, if a transient load (a large amount of load applied in a short period of time, such as pulse. is applied, confirmation of performance characteristics after on-board mounting is strongly recommended. Avoid applying power exceeding normal rated power; exceeding the power rating under steady-state loading condition may negatively affect product performance and reliability.
- De-rate Power Dissipation depending on ambient temperature. When used in sealed area, confirm that it is the use in the range that does not exceed the maximum junction temperature.
- Confirm that operation temperature is within the specified range described in the product specification.
- ROHM shall not be in any way responsible or liable for failure induced under deviant condition from what is defined in this document.

## Precaution for Mounting / Circuit board design

- When a highly active halogenous (chlorine, bromine, etc.) flux is used, the residue of flux may negatively affect product performance and reliability.
- In principle, the reflow soldering method must be used on a surface-mount products, the flow soldering method must be used on a through hole mount products. If the flow soldering method is preferred on a surface-mount products, please consult with the ROHM representative in advance.

For details, please refer to ROHM Mounting specification

### Precautions Regarding Application Examples and External Circuits

1. If change is made to the constant of an external circuit, please allow a sufficient margin considering variations of the characteristics of the Products and external components, including transient characteristics, as well as static characteristics.
2. You agree that application notes, reference designs, and associated data and information contained in this document are presented only as guidance for Products use. Therefore, in case you use such information, you are solely responsible for it and you must exercise your own independent verification and judgment in the use of such information contained in this document. ROHM shall not be in any way responsible or liable for any damages, expenses or losses incurred by you or third parties arising from the use of such information.

### Precaution for Electrostatic

This Product is electrostatic sensitive product, which may be damaged due to electrostatic discharge. Please take proper caution in your manufacturing process and storage so that voltage exceeding the Products maximum rating will not be applied to Products. Please take special care under dry condition (e.g. Grounding of human body / equipment / solder iron, isolation from charged objects, setting of Ionizer, friction prevention and temperature / humidity control).

### Precaution for Storage / Transportation

1. Product performance and soldered connections may deteriorate if the Products are stored in the places where:
  - [a] the Products are exposed to sea winds or corrosive gases, including Cl<sub>2</sub>, H<sub>2</sub>S, NH<sub>3</sub>, SO<sub>2</sub>, and NO<sub>2</sub>
  - [b] the temperature or humidity exceeds those recommended by ROHM
  - [c] the Products are exposed to direct sunshine or condensation
  - [d] the Products are exposed to high Electrostatic
2. Even under ROHM recommended storage condition, solderability of products out of recommended storage time period may be degraded. It is strongly recommended to confirm solderability before using Products of which storage time is exceeding the recommended storage time period.
3. Store / transport cartons in the correct direction, which is indicated on a carton with a symbol. Otherwise bent leads may occur due to excessive stress applied when dropping of a carton.
4. Use Products within the specified time after opening a humidity barrier bag. Baking is required before using Products of which storage time is exceeding the recommended storage time period.

### Precaution for Product Label

A two-dimensional barcode printed on ROHM Products label is for ROHM's internal use only.

### Precaution for Disposition

When disposing Products please dispose them properly using an authorized industry waste company.

### Precaution for Foreign Exchange and Foreign Trade act

Since concerned goods might be fallen under listed items of export control prescribed by Foreign exchange and Foreign trade act, please consult with ROHM in case of export.

### Precaution Regarding Intellectual Property Rights

1. All information and data including but not limited to application example contained in this document is for reference only. ROHM does not warrant that foregoing information or data will not infringe any intellectual property rights or any other rights of any third party regarding such information or data.
2. ROHM shall not have any obligations where the claims, actions or demands arising from the combination of the Products with other articles such as components, circuits, systems or external equipment (including software).
3. No license, expressly or implied, is granted hereby under any intellectual property rights or other rights of ROHM or any third parties with respect to the Products or the information contained in this document. Provided, however, that ROHM will not assert its intellectual property rights or other rights against you or your customers to the extent necessary to manufacture or sell products containing the Products, subject to the terms and conditions herein.

### Other Precaution

1. This document may not be reprinted or reproduced, in whole or in part, without prior written consent of ROHM.
2. The Products may not be disassembled, converted, modified, reproduced or otherwise changed without prior written consent of ROHM.
3. In no event shall you use in any way whatsoever the Products and the related technical information contained in the Products or this document for any military purposes, including but not limited to, the development of mass-destruction weapons.
4. The proper names of companies or products described in this document are trademarks or registered trademarks of ROHM, its affiliated companies or third parties.

**General Precaution**

1. Before you use our Products, you are requested to carefully read this document and fully understand its contents. ROHM shall not be in any way responsible or liable for failure, malfunction or accident arising from the use of any ROHM's Products against warning, caution or note contained in this document.
2. All information contained in this document is current as of the issuing date and subject to change without any prior notice. Before purchasing or using ROHM's Products, please confirm the latest information with a ROHM sales representative.
3. The information contained in this document is provided on an "as is" basis and ROHM does not warrant that all information contained in this document is accurate and/or error-free. ROHM shall not be in any way responsible or liable for any damages, expenses or losses incurred by you or third parties resulting from inaccuracy or errors of or concerning such information.