

CABLINE® - VS

VESA standard connector, Suitable for high-data-rate transfer (32 Gbps/lane), Mechanical locking bar, 0.5 mm pitch, Horizontal mating type micro-coaxial connector

Product Specifications:

Mating type	Horizontal	
Board Pitch	0.5 mm	
Wiping Length	0.61 mm	
Mated Size	Height	1.0 +/- 0.1 mm
	Width	7.55 + (0.5 x pin count) mm
	Depth	5.8 mm
Pin Counts	Range	Up to 60
	Available	20, 30, 40, 50

Applicable Cable Size:

Maximum O.D.	0.5 mm
Micro-Coaxial for Signal	45 ohm: AWG 36 or smaller 50 ohm: AWG 38 or smaller
Twinaxial	AWG 40
Discrete	AWG 32 or smaller

Applicable Standards (Reference Only):

32 Gbps/ Lane, USB4 Gen4 (40 Gbps/ Lane PAM3) Display Port UHBR20 (20 Gbps/Lane)

* Please inquire for pin counts not listed or outside of the pin count range.

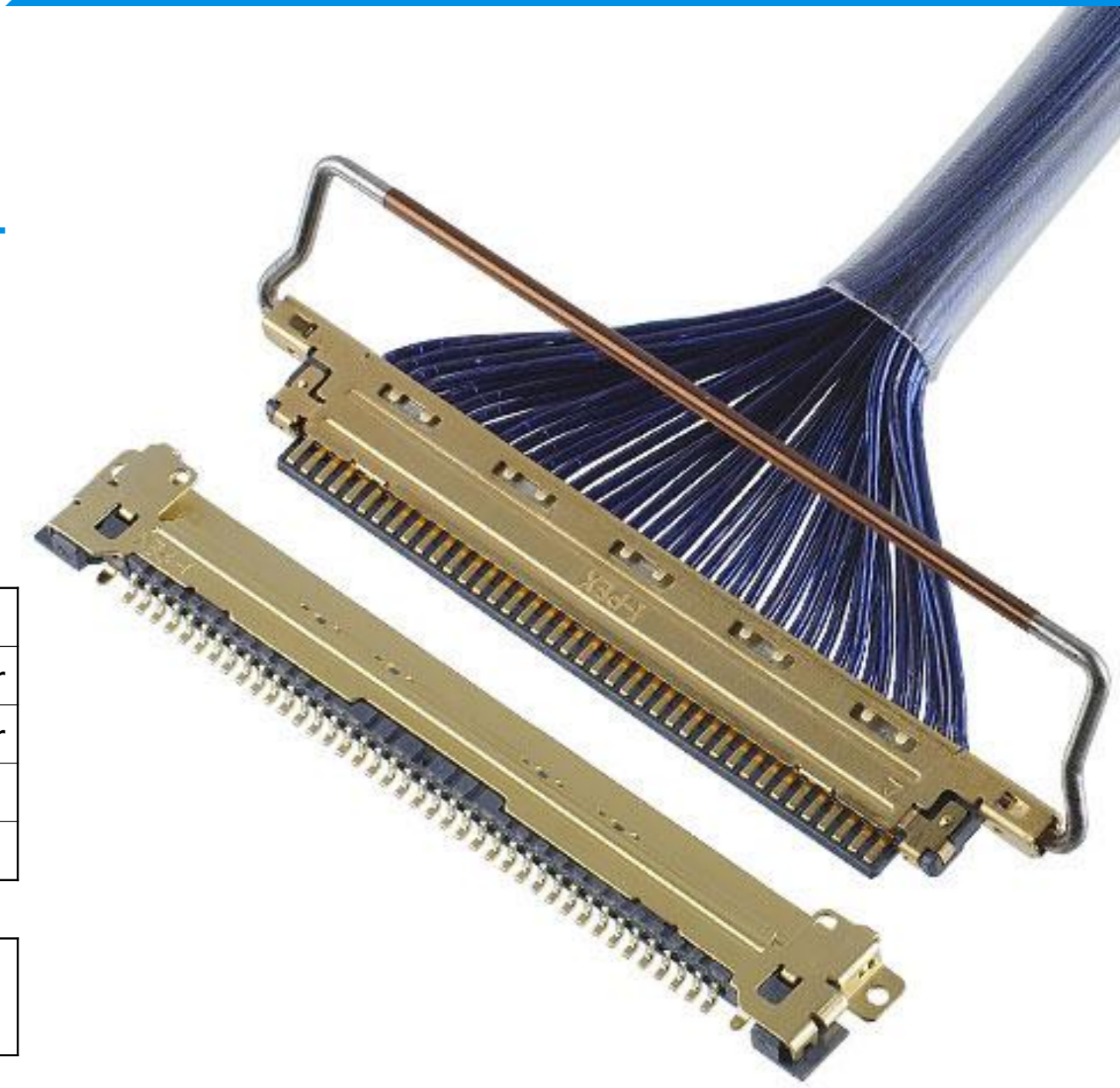

High-data-rate transfer, ideal for 32 Gbps/lane applications

Measurement results

Connector: CABLINE-VS 40 pin

Cable: Micro-coaxial cable
AWG 40, 45ohm, Length: 100 mm

Pin Assignment: GSSGSSG

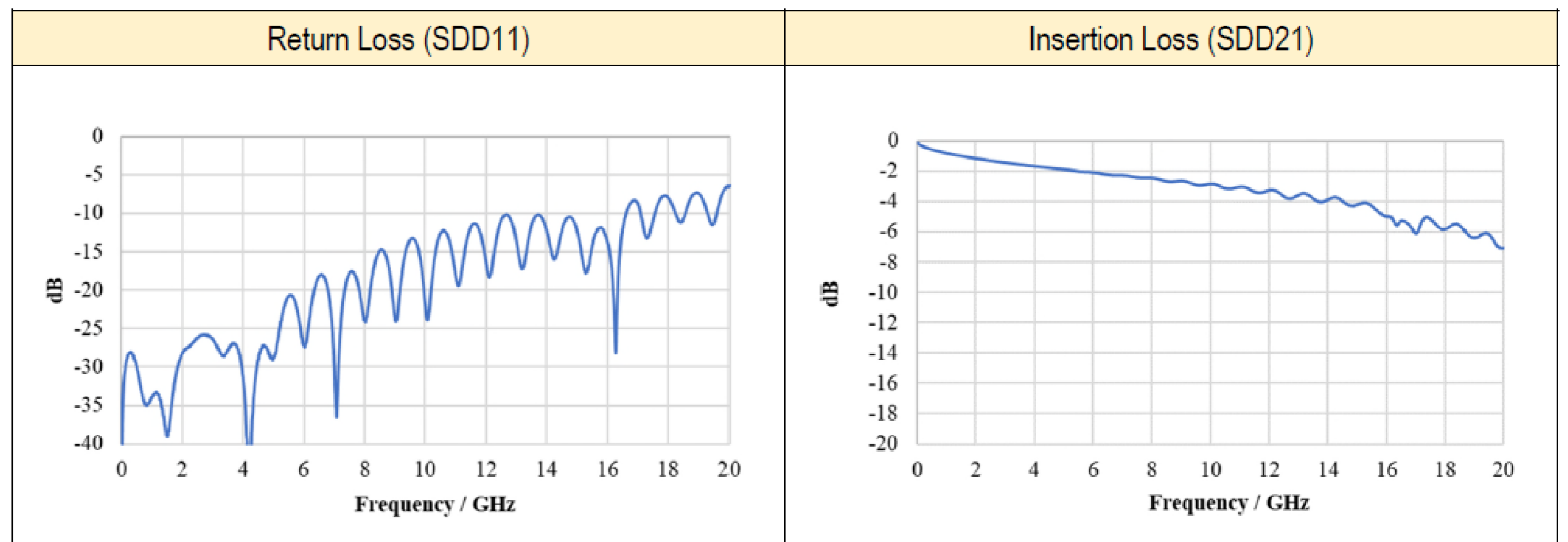

Mechanical locking bar prevents incomplete mating and back-out/unmating

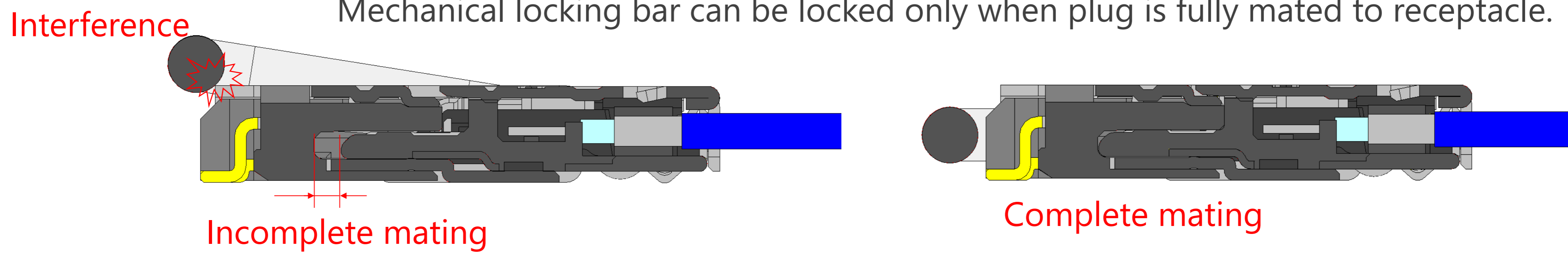
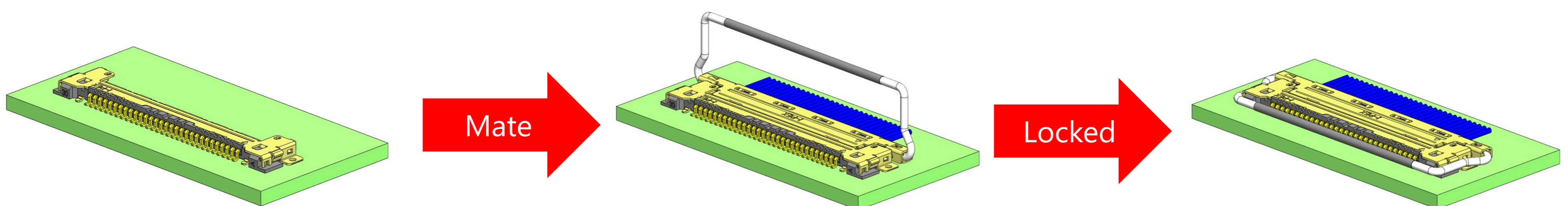

Multiple connector options with I-PEX VS series

I-PEX VS series (0.5 mm pitch, horizontal mating type)

CABLINE-VS, VS II receptacles and EVAFLEX® 5-VS can be mounted to the same PCB layout.

CABLINE-VS Receptacle:
Has #1 share in the Notebook PC panel connector market as VESA standard connector.

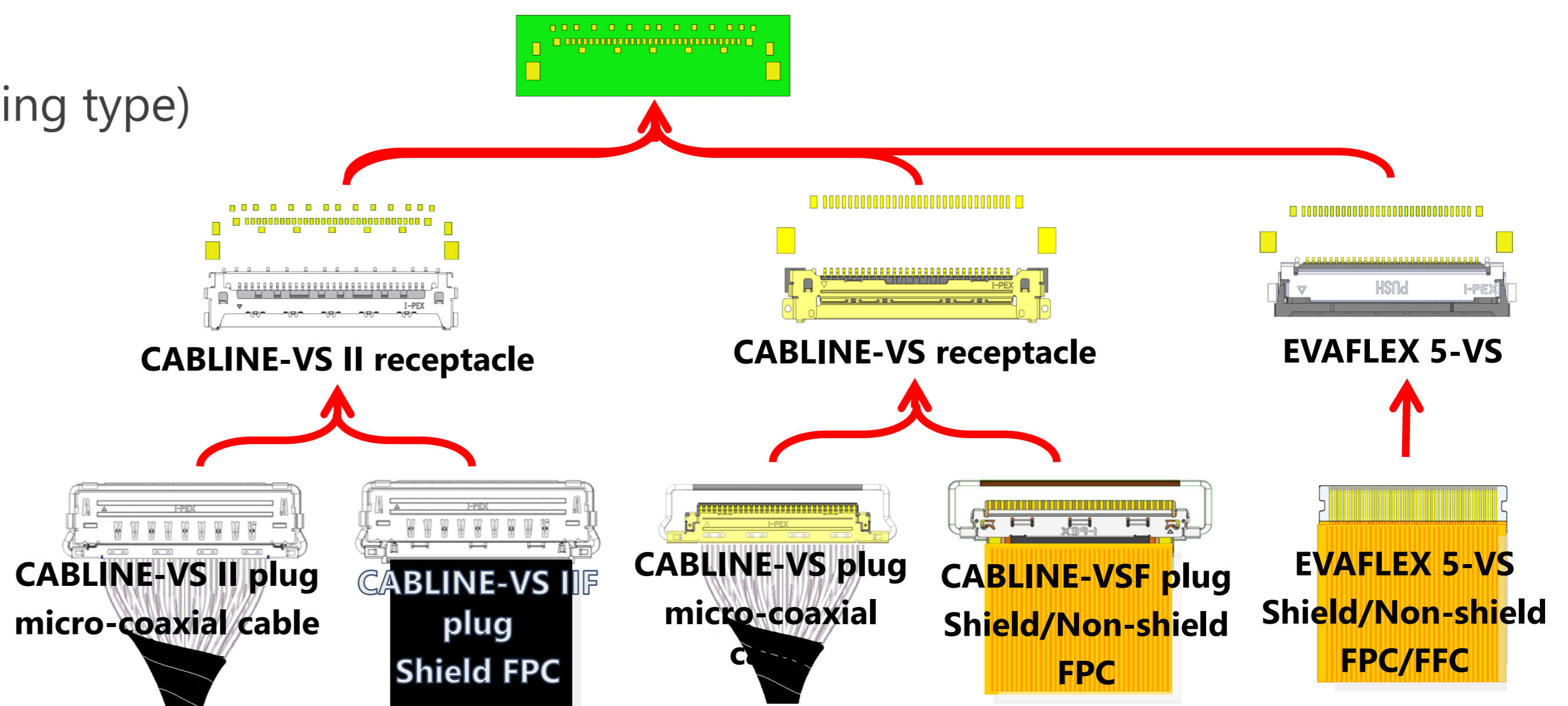

CABLINE® -VS standard harness

- ◆ Please click the part number to get its 2D drawing.
- ◆ Please be advised that if it becomes necessary to change the harness specifications, the part number will also need to be updated. The following part number is valid only when used with the harness specifications shown below.
- ◆ Please contact us via [Inquiry form](#) for other harness specifications.

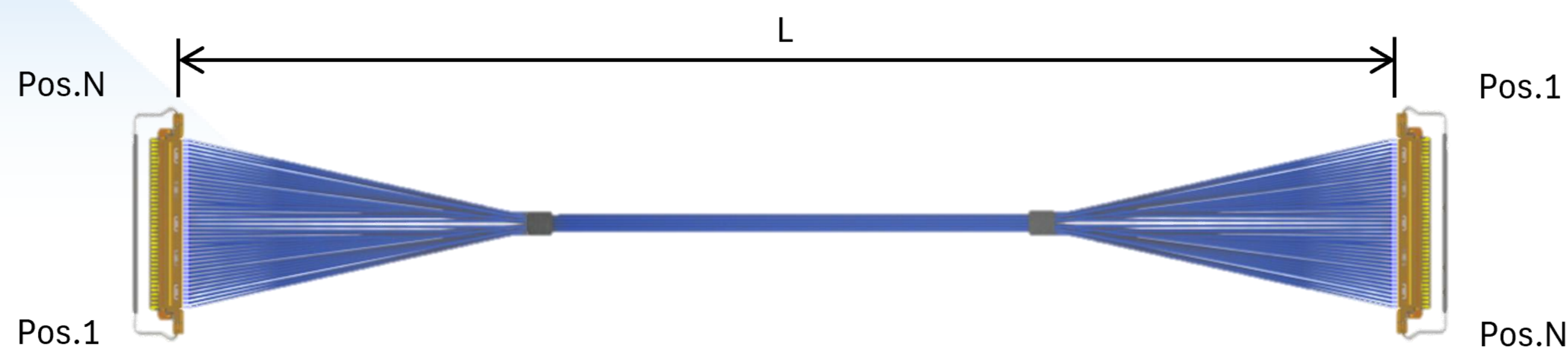

Part Number Description	Part Number (Link to Drawing)	Sample available
CABLINE-VS harness 20pin micro-coaxial 40AWG L=200mm 1-N	82067-100B-02-D	Buy from Digikey
CABLINE-VS harness 30pin micro-coaxial 40AWG L=100mm 1-N	82189-100B-02-D	Buy from Digikey
CABLINE-VS harness 30pin micro-coaxial 40AWG L=200mm 1-N	81421-100B-02-D	Buy from Digikey
CABLINE-VS harness 30pin micro-coaxial 40AWG L=300mm 1-N	82289-100B-02-D	Buy from Digikey
CABLINE-VS harness 40pin micro-coaxial 40AWG L=100mm 1-N	82190-100B-02-D	Buy from Digikey
CABLINE-VS harness 40pin micro-coaxial 40AWG L=200mm 1-N	81422-100B-02-D	Buy from Digikey
CABLINE-VS harness 40pin micro-coaxial 40AWG L=300mm 1-N	82290-100B-02-D	Buy from Digikey
CABLINE-VS harness 50pin micro-coaxial 40AWG L=200mm 1-N	82450-100B-02-D	Buy from Digikey

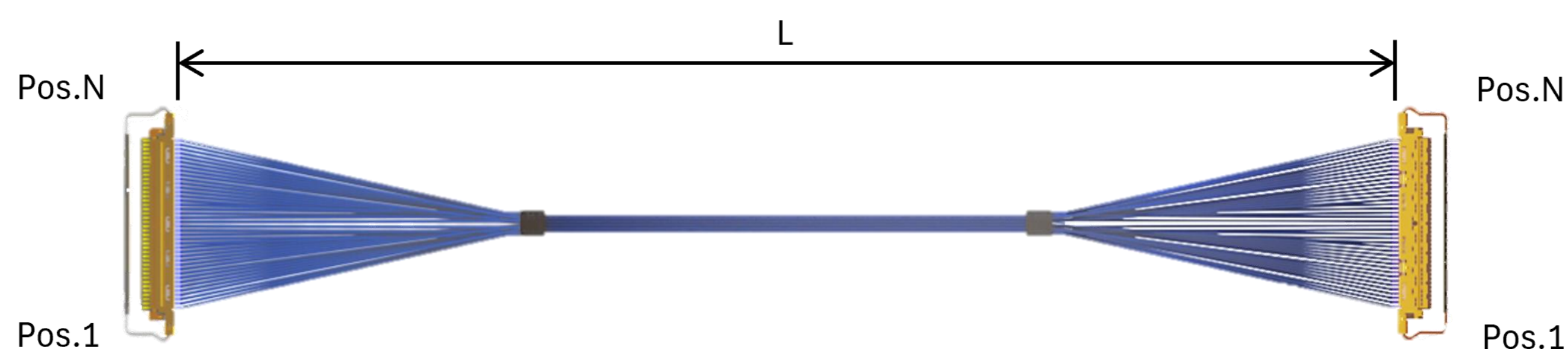

Part Number Description	Part Number (Link to Drawing)	Sample available
CABLINE-VS harness 30pin micro-coaxial 40AWG L=100mm 1-1	82687-100B-01-D	Contact us
CABLINE-VS harness 30pin micro-coaxial 40AWG L=200mm 1-1	82688-100B-01-D	Contact us
CABLINE-VS harness 30pin micro-coaxial 40AWG L=300mm 1-1	82689-100B-01-D	Contact us
CABLINE-VS harness 40pin micro-coaxial 40AWG L=100mm 1-1	82690-100B-01-D	Contact us
CABLINE-VS harness 40pin micro-coaxial 40AWG L=200mm 1-1	82691-100B-01-D	Contact us
CABLINE-VS harness 40pin micro-coaxial 40AWG L=300mm 1-1	82692-100B-01-D	Contact us

Component Parts Details

Component Parts

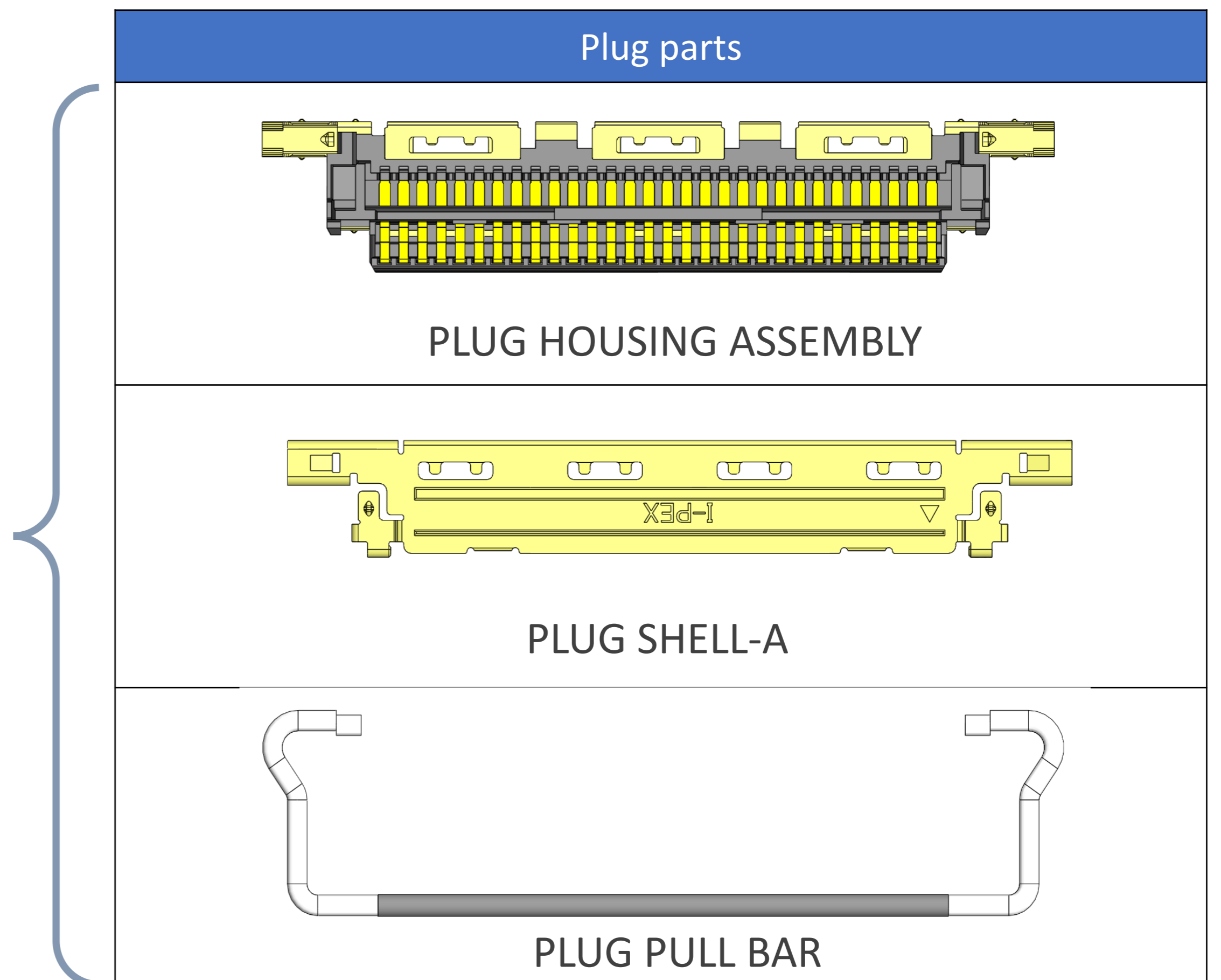
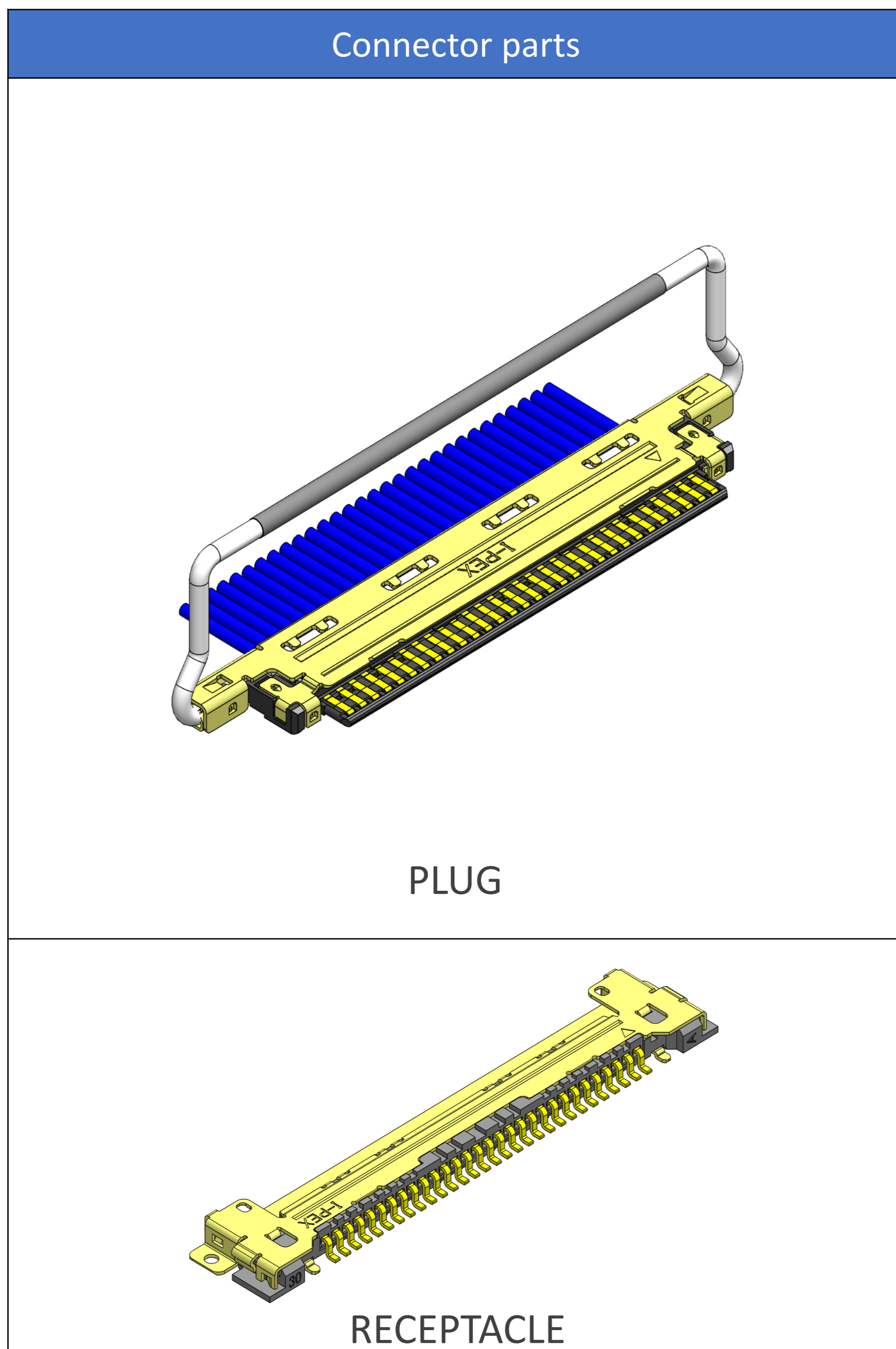

Plug for Cable Assembly

Recommended P/N		20453-2**T-03(20P/30P/40P)								20453-250T-03S(50P)	
PART NO.	Pos.	A	B	C	D	E	F	G	H		
20453-#20T-#1	20	9.50	10.30	12.56	16.00	16.15	13.00	17.55	14.45		
20453-#30T-#1	30	14.50	15.30	17.56	21.00	21.15	18.00	22.55	19.45		
20453-#40T-#1	40	19.50	20.30	22.56	26.00	26.15	23.00	27.55	24.45		
20453-#50T-#1S	50	24.50	25.30	27.56	31.00	31.15	28.00	32.55	29.45		

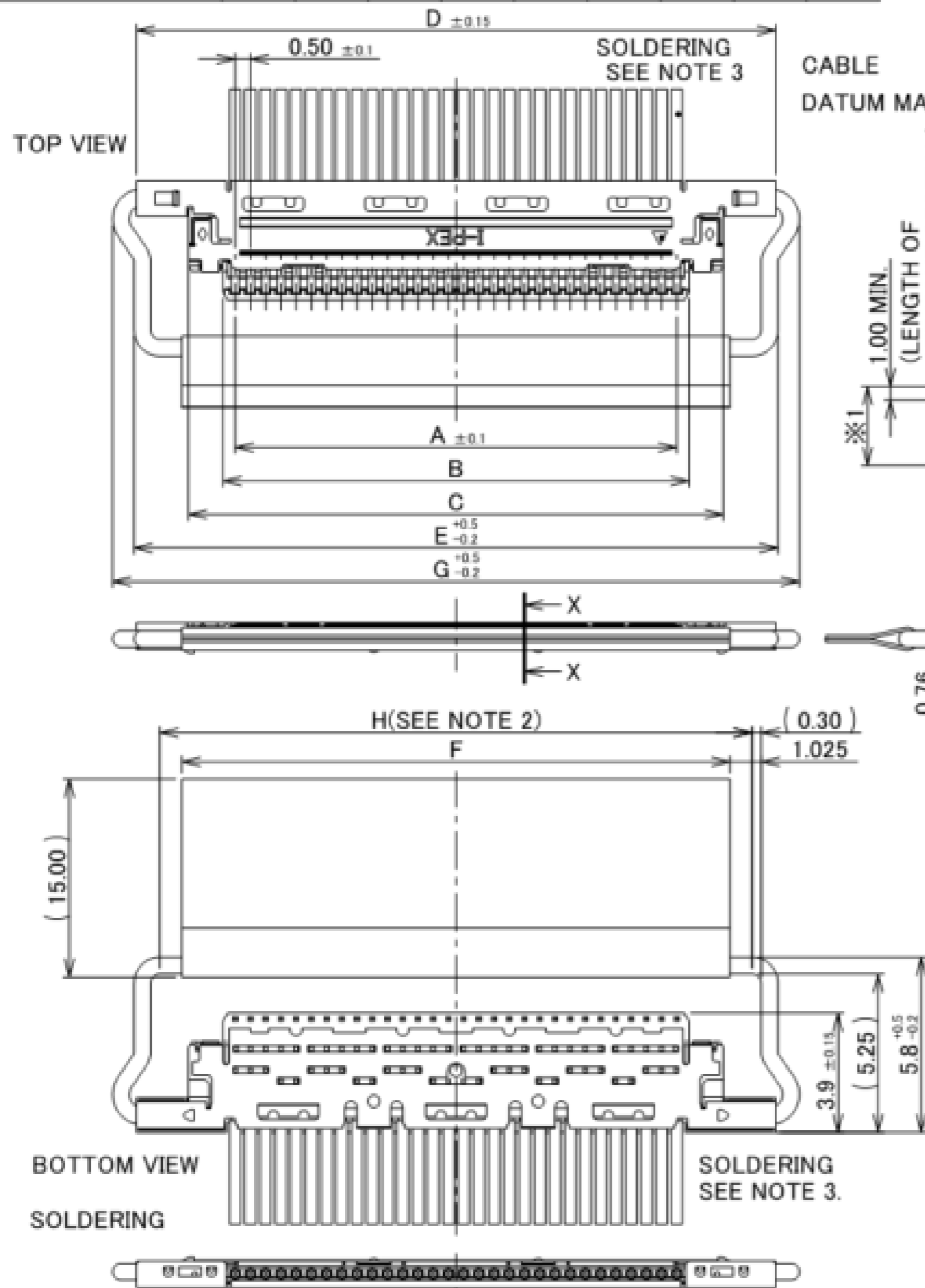

WITH PULL-BAR & PULL-TAPE

NOTHING : HOUSING ASSEMBLY P/N 20454-##*T
S : HOUSING ASSEMBLY P/N 20454-##*T-01

- 1 : WITH PULL-BAR P/N 2576-0**00
 - 2 : WITHOUT PULL-BAR
 - 3 : WITH INSULATION COAT PULL-BAR P/N 2576-1**00
 - 0 : WITH DATUM MARK P/N 2574-0**#
 - 1 : WITHOUT DATUM MARK P/N 2574-1**#
- SEE TABLE 1.

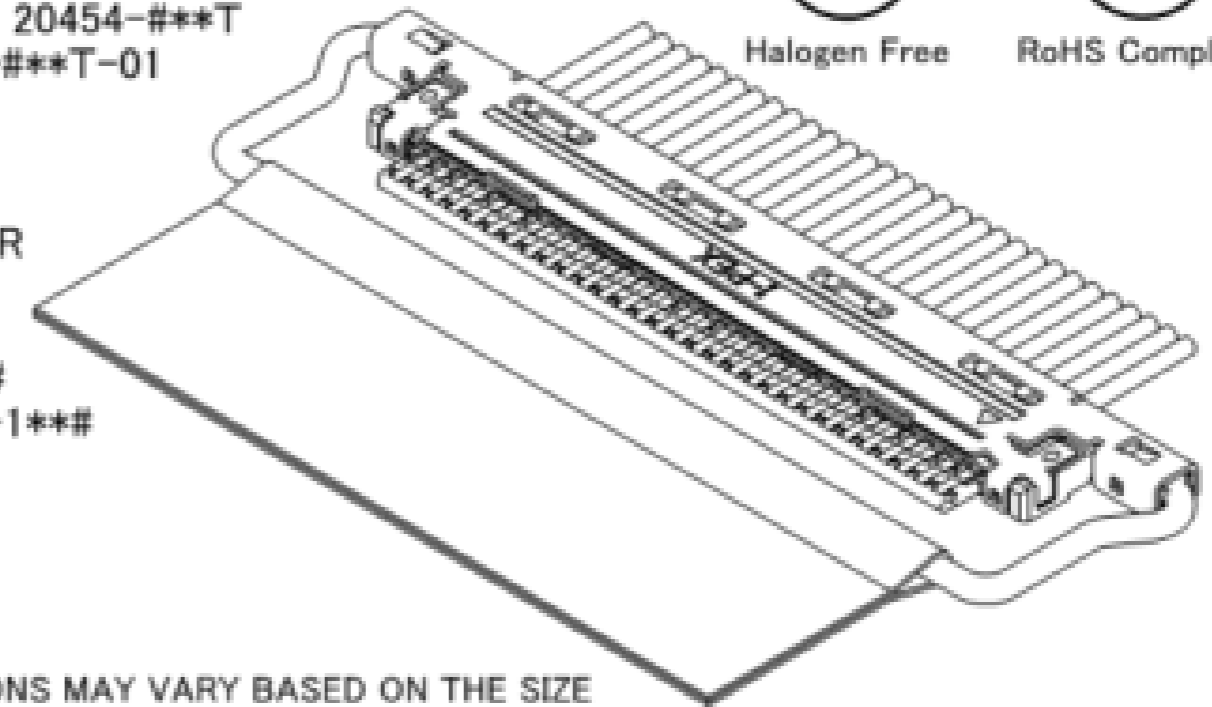

※1: THE BEND DIMENSIONS MAY VARY BASED ON THE SIZE AND QUANTITY OF CABLES. PLEASE CONFIRM THE MINIMUM BENDING RADIUS WITH I-PEX OR THE HARNESS MANUFACTURER.

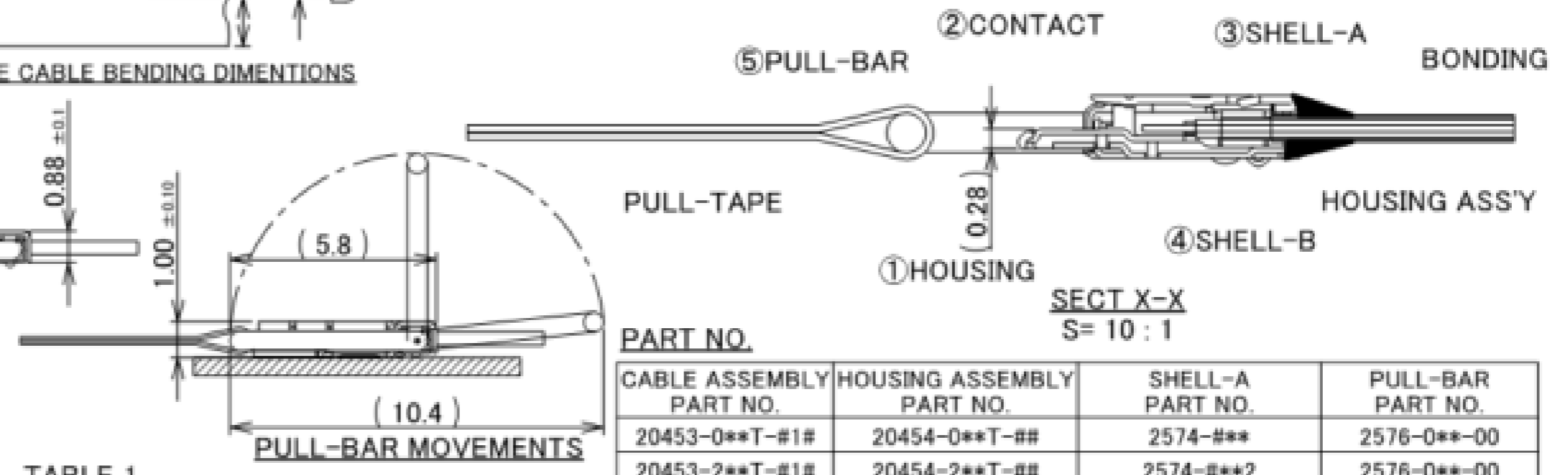

TABLE 1

PART NO.	CONTACT FINISH	SHELL-A FINISH		SHELL-B FINISH
		TOP SIDE	BOTTOM SIDE	
20453-0**T-##	CONTACT AREA : Au 0.1 μm MIN. OVER Ni 1.00 μm MIN. SOLDERING AREA : Au 0.05 μm MIN. OVER Ni 1.00 μm MIN.	Au 0.05 μm MIN. OVER Ni 1.00 μm MIN.	Au 0.015 μm MIN. OVER Ni 1.00 μm MIN.	TOP SIDE : Au 0.015 μm MIN. OVER Ni 1.00 μm MIN. BOTTOM SIDE : Au 0.05 μm MIN. OVER Ni 1.00 μm MIN.
20453-2**T-##	CONTACT AREA : Au 0.1 μm MIN. OVER Ni 1.00 μm MIN. SOLDERING AREA : Au 0.05 μm MIN. OVER Ni 1.00 μm MIN.	Au 0.03 μm MIN. OVER Ni 1.00 μm MIN.	Ni 1.00 μm MIN. (THERE IS THE POSSIBILITY THAT Au ATTACHES RANDOMLY)	TOP SIDE : Ni 1.00 μm MIN. (THERE IS THE POSSIBILITY THAT Au ATTACHES RANDOMLY) BOTTOM SIDE : Au 0.03 μm MIN. OVER Ni 1.00 μm MIN.

NO.	DISCRIPTION	MATERIAL	FINISH . REMARKS
5	PULL-BAR	SUS	
4	SHELL-B	PHOSPHOR BRONZE	SEE ABOVE TABLE 1.
3	SHELL-A	PHOSPHOR BRONZE	SEE ABOVE TABLE 1.
2	CONTACT	PHOSPHOR BRONZE	SEE ABOVE TABLE 1.
1	HOUSING	LCP	UL94V-0, BLACK

- NOTES.
1. RECOMMENDED PULL-TAPE
PULL-TAPE : TERAOKA'S INSULATION TAPE No.650S(#50) t=0.08
 2. PULL-TAPE CAN BE PUT WITHIN THE RANGE OF "H" (STRAIGHT AREA)
 3. SOLDERING IS ONLY A CASE WITH GND-BAR

Rev.38

Recommended P/N		20453-2**T-03(20P/30P/40P)				20453-250T-03S(50P)	
PART NO.	Pos.	A	B	C	D		
20453-#20T-#2	20	9.50	10.30	12.56	16.00		
20453-#30T-#2	30	14.50	15.30	17.56	21.00		
20453-#40T-#2	40	19.50	20.30	22.56	26.00		
20453-#50T-#2S	50	24.50	25.30	27.56	31.00		

WITHOUT PULL-BAR

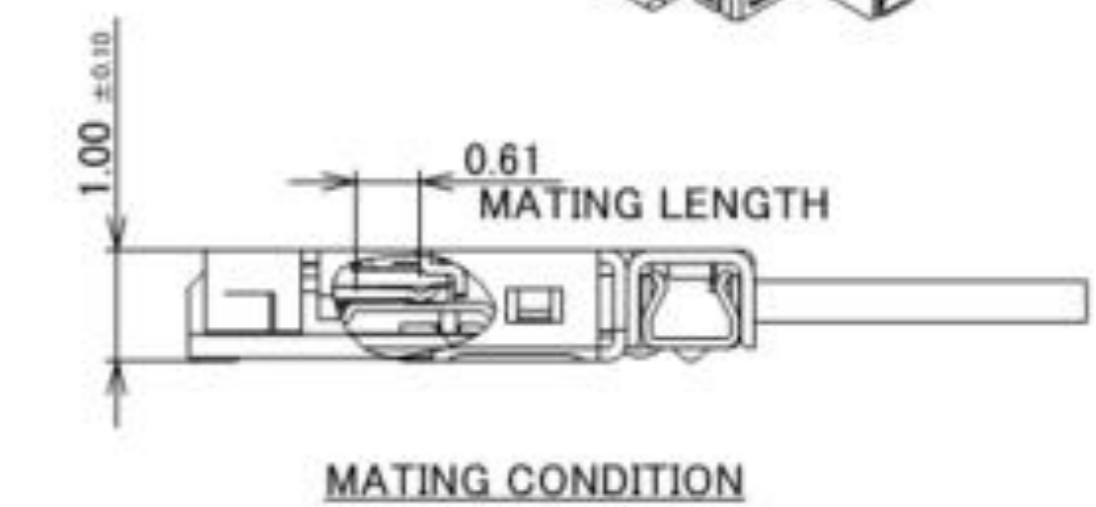
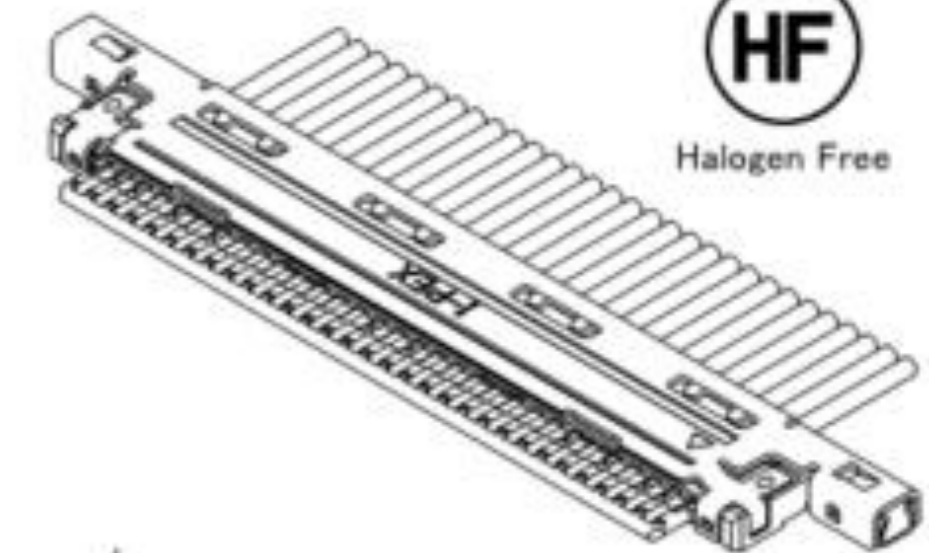
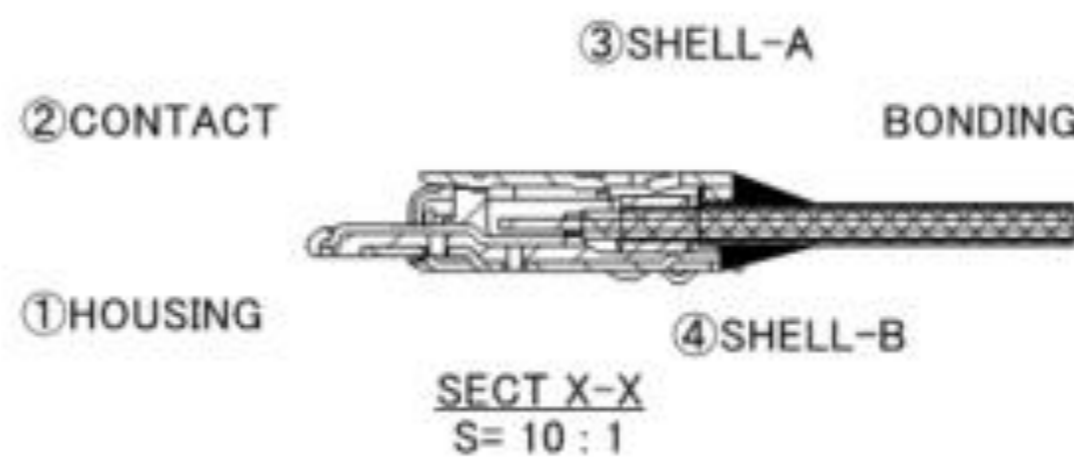
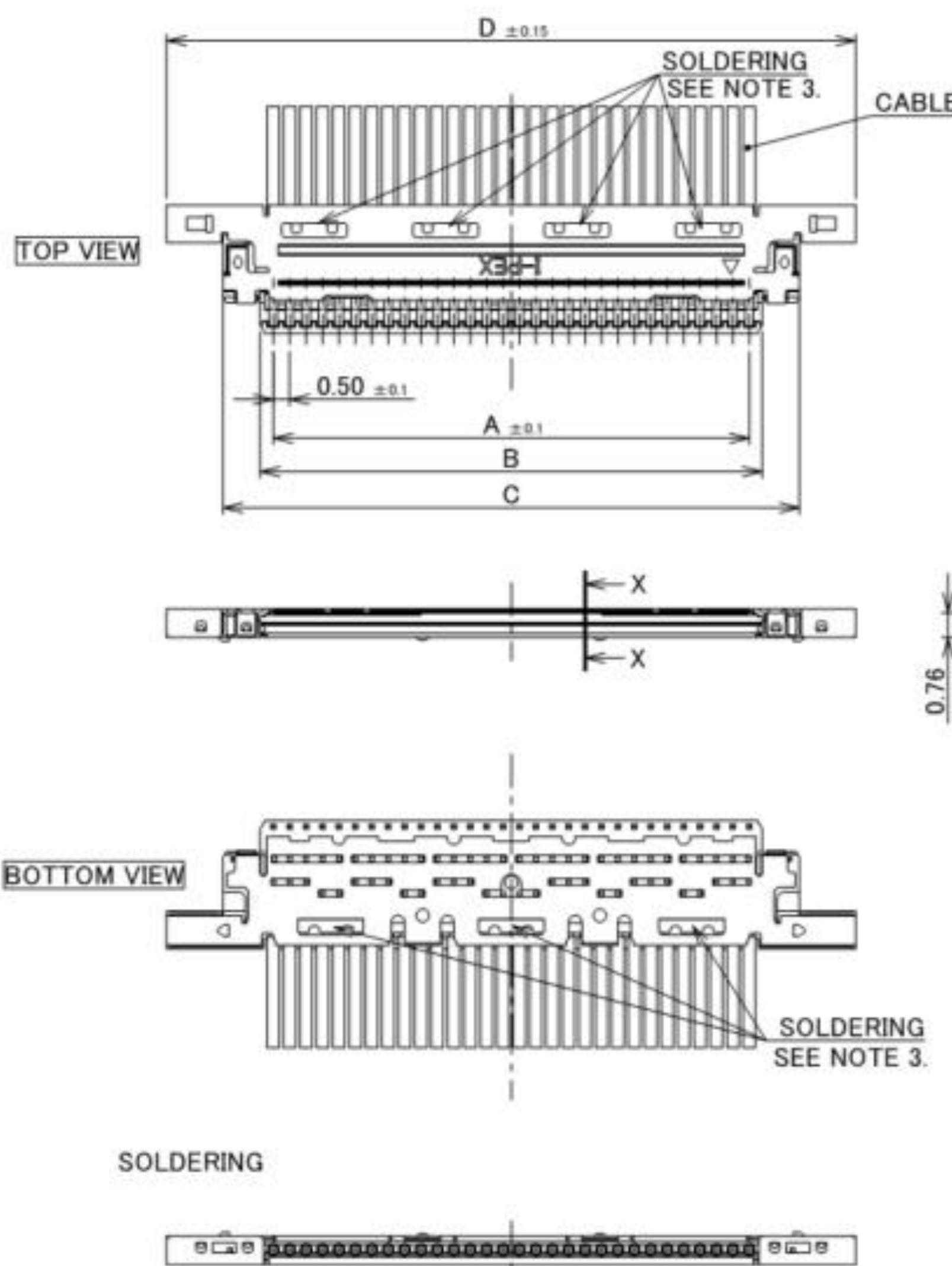

PLUG P/N : 20453-##*T-#2#

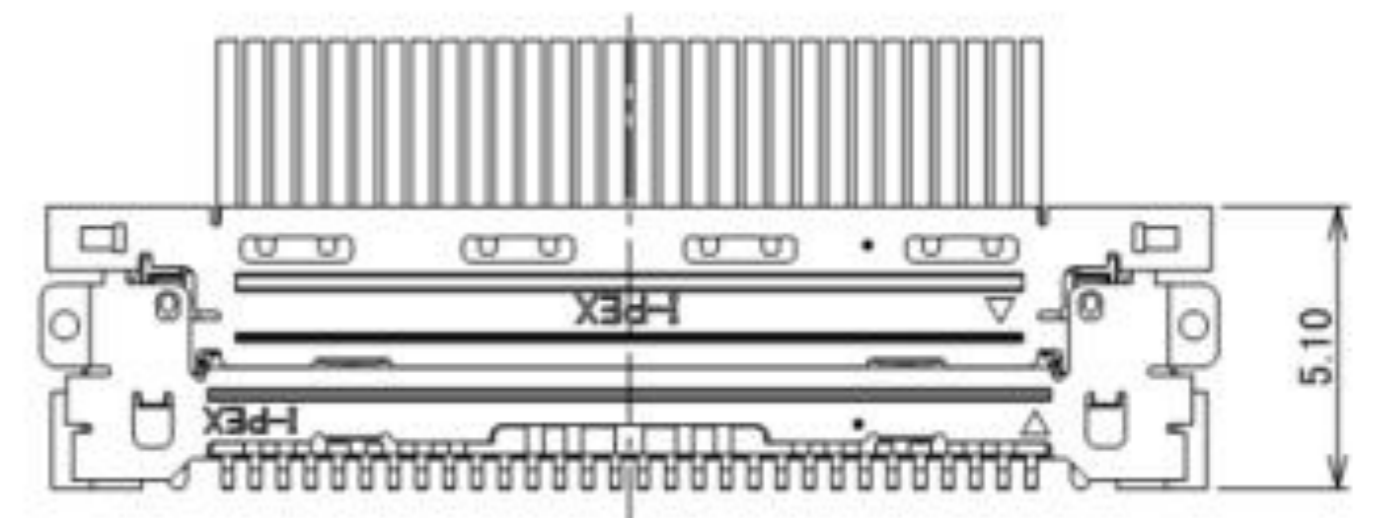

RECEPTACLE P/N : 20455-##*E-##

PART NO.	CABLE ASSEMBLY PART NO.	HOUSING ASSEMBLY PART NO.	SHELL-A PART NO.	PULL-BAR PART NO.
20453-0**T-#2#		20454-0**T-##	2574-##	-
20453-2**T-#2#		20454-2**T-##	2574-##*2	-

Rev.38

Plug for Cable Assembly

Recommended P/N		20453-2**T-03(20P/30P/40P)						20453-250T-03S(50P)	
PART NO.	Pos.	A	B	C	D	E	G		
20453-#20T-#3	20	9.50	10.30	12.56	16.00	16.15	17.55		
20453-#30T-#3	30	14.50	15.30	17.56	21.00	21.15	22.55		
20453-#40T-#3	40	19.50	20.30	22.56	26.00	26.15	27.55		
20453-#50T-#3S	50	24.50	25.30	27.56	31.00	31.15	32.55		

WITH INSULATION COAT PULL-BAR

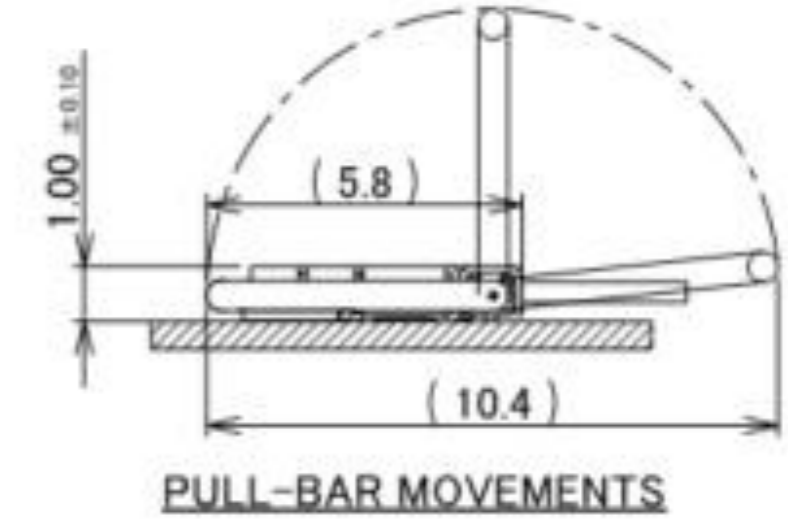
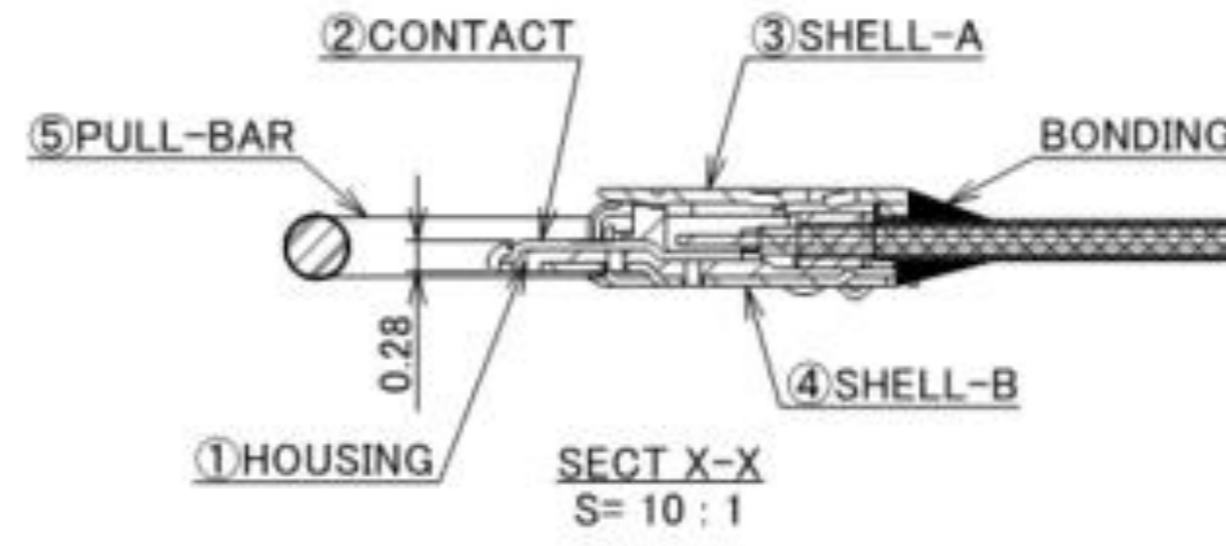
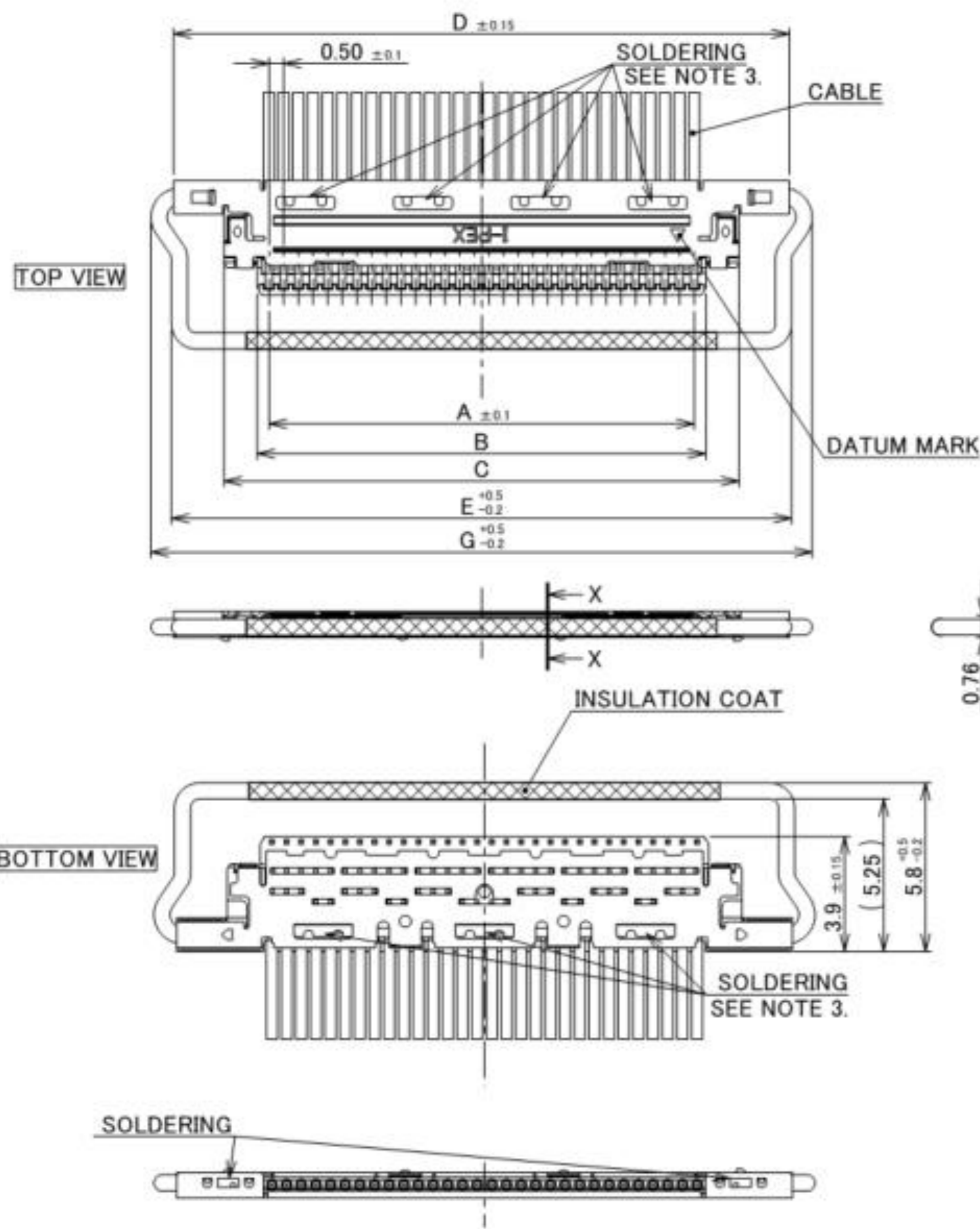
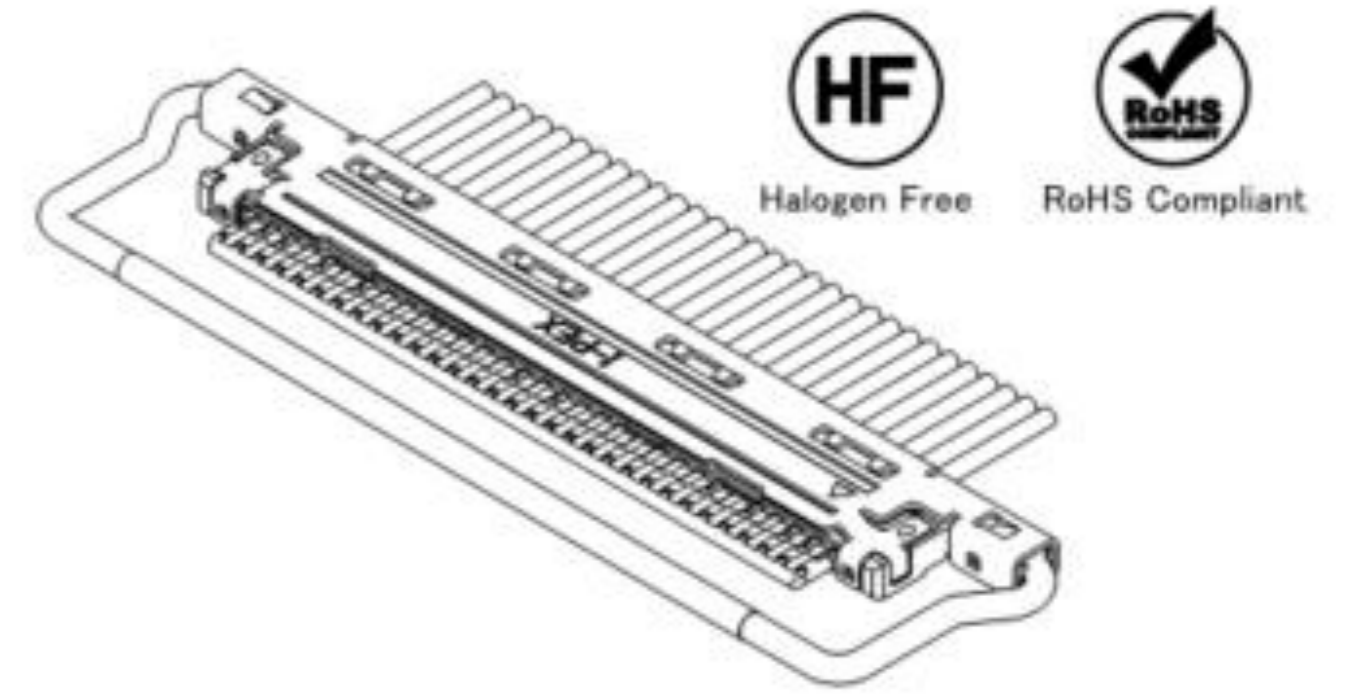

PART NO.			
CABLE ASSEMBLY PART NO.	HOUSING ASSEMBLY PART NO.	SHELL-A PART NO.	PULL-BAR PART NO.
20453-0**T-#3#	20454-0**T-##	2574-###	2576-1**-00
20453-2**T-#3#	20454-2**T-##	2574-##+2	2576-1**-00

Rev.38

PART NO.	Pos.	A
20453-#20T-##	20	9.50
20453-#30T-##	30	14.50
20453-#40T-##	40	19.50
20453-#50T-##S	50	24.50

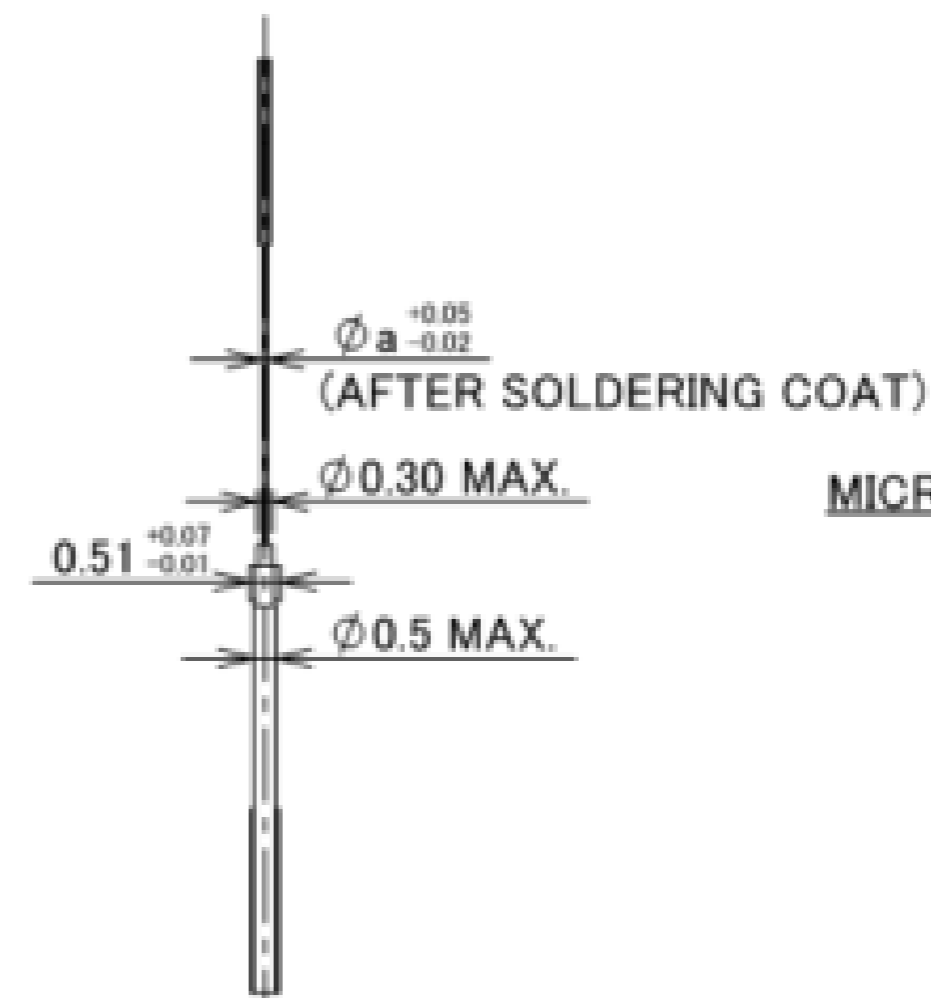
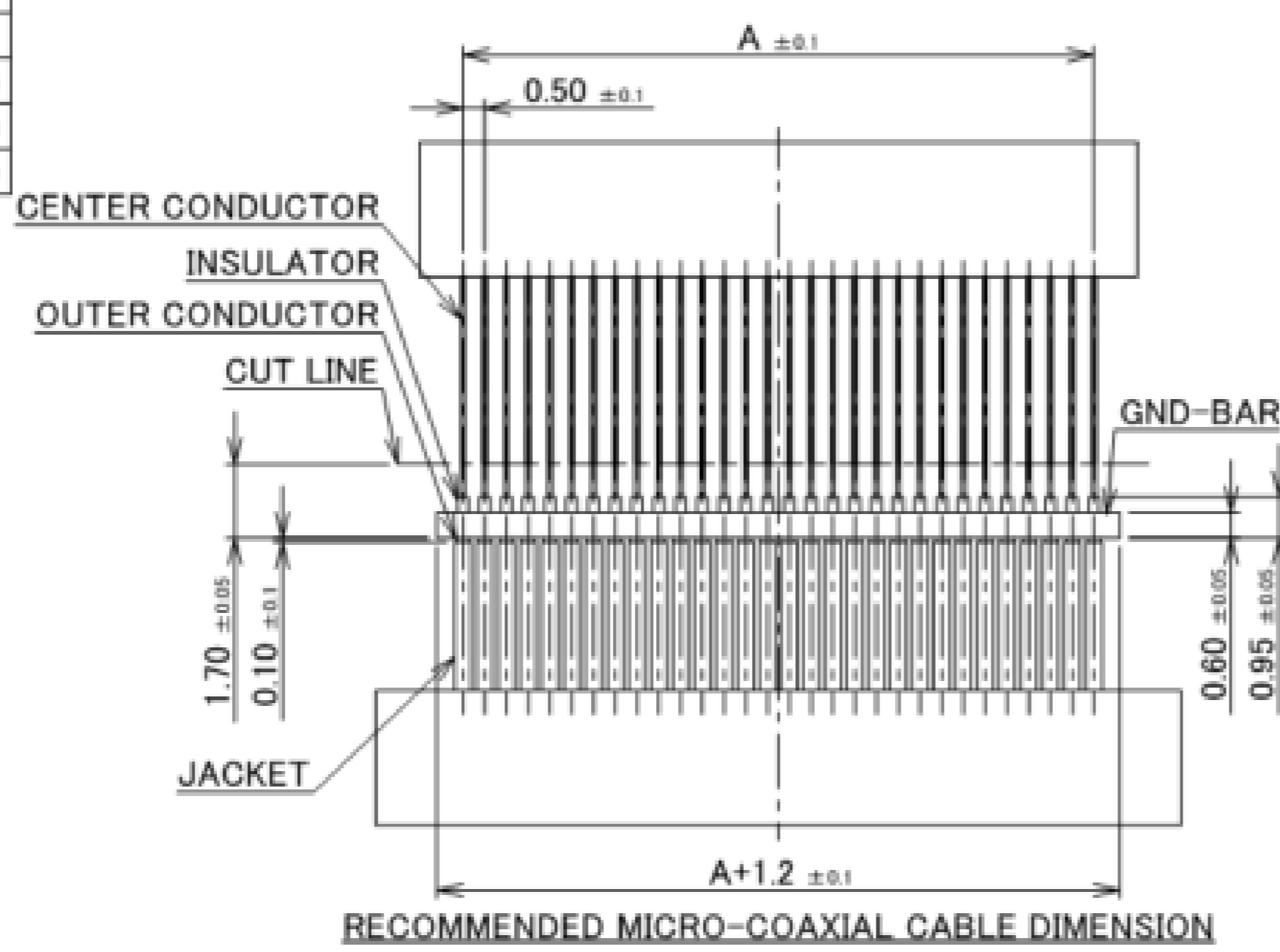

MICRO-COAXIAL CABLE DIMENSION

	a
#36	0.15
#38	0.12
#40	0.09
#42	0.075
#44	0.063

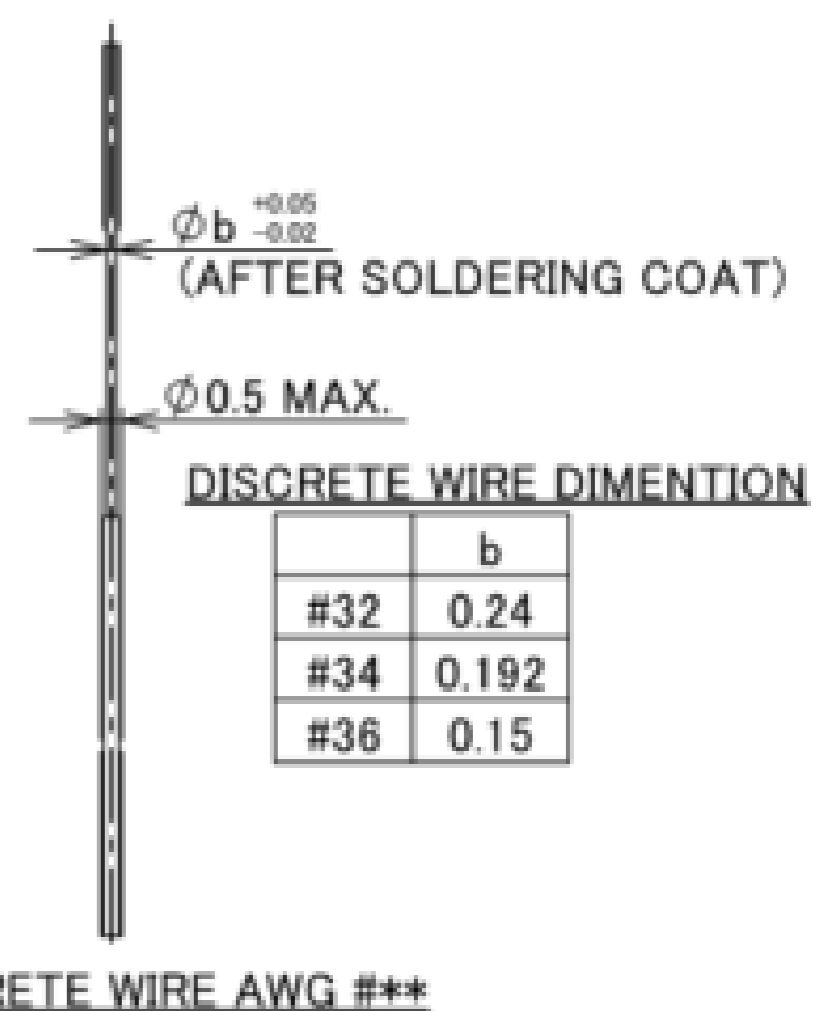
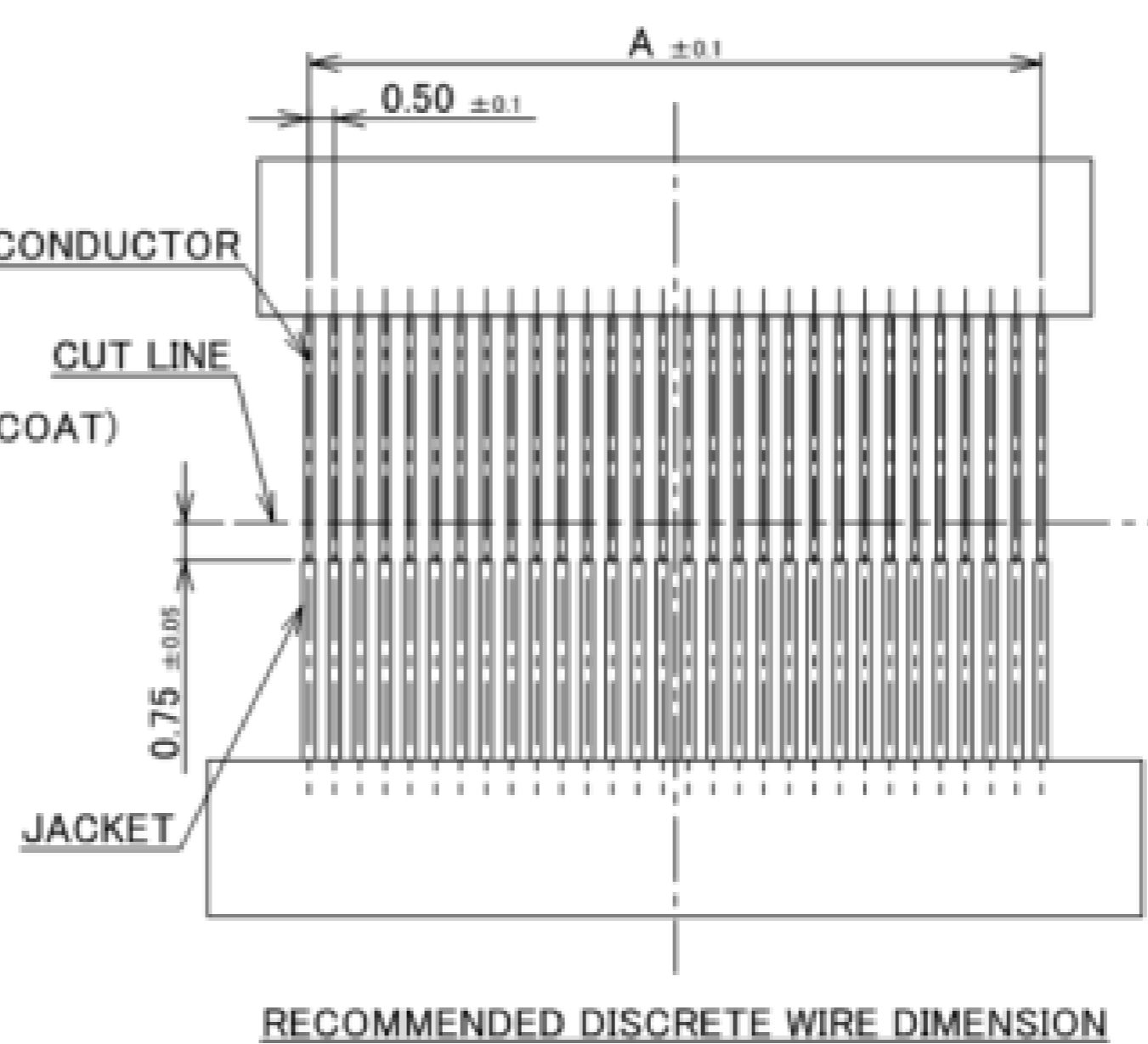
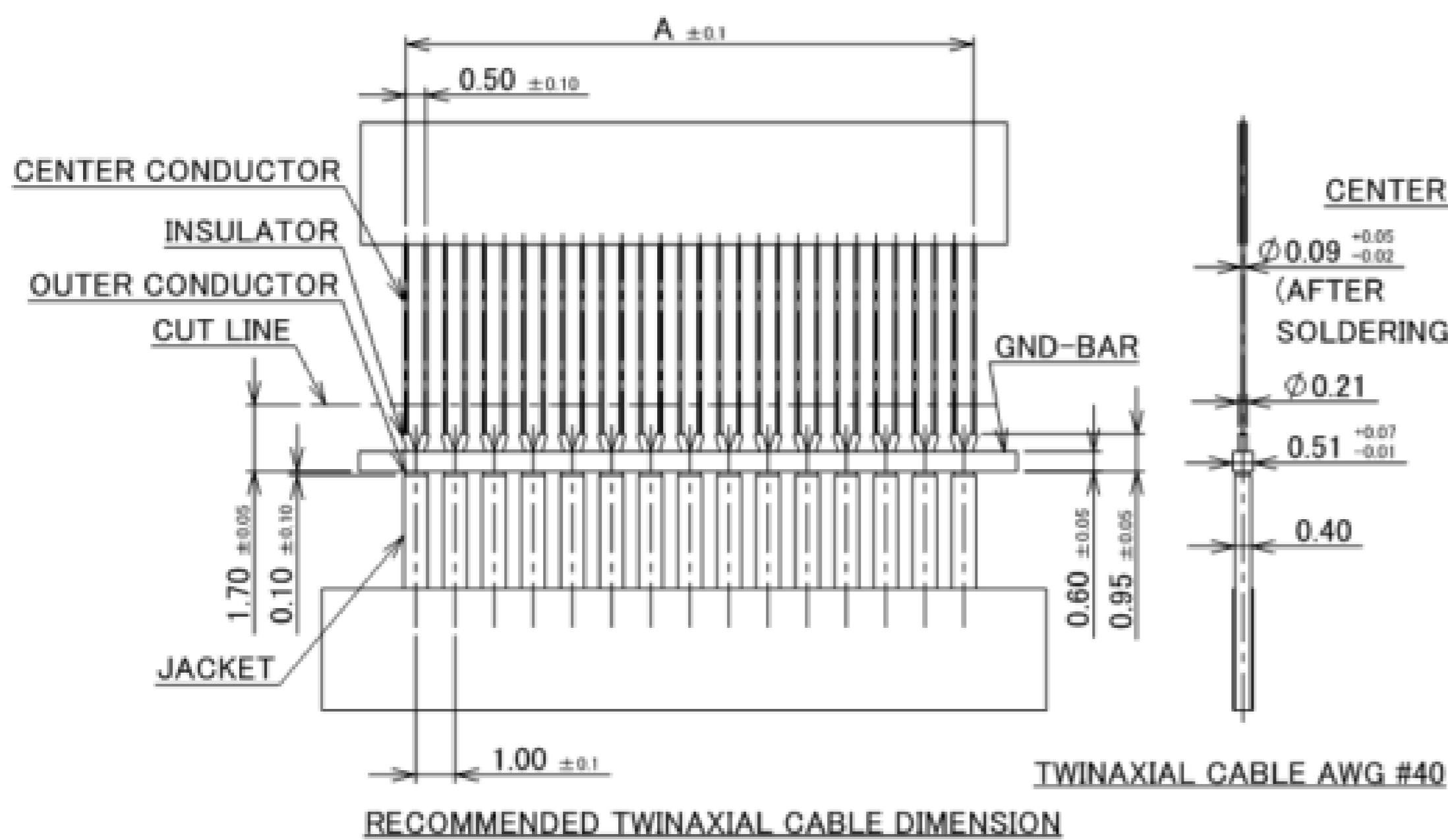

	b
#32	0.24
#34	0.192
#36	0.15

Rev.38

Plug for Cable Assembly

THE EXTERNAL APPEARANCE

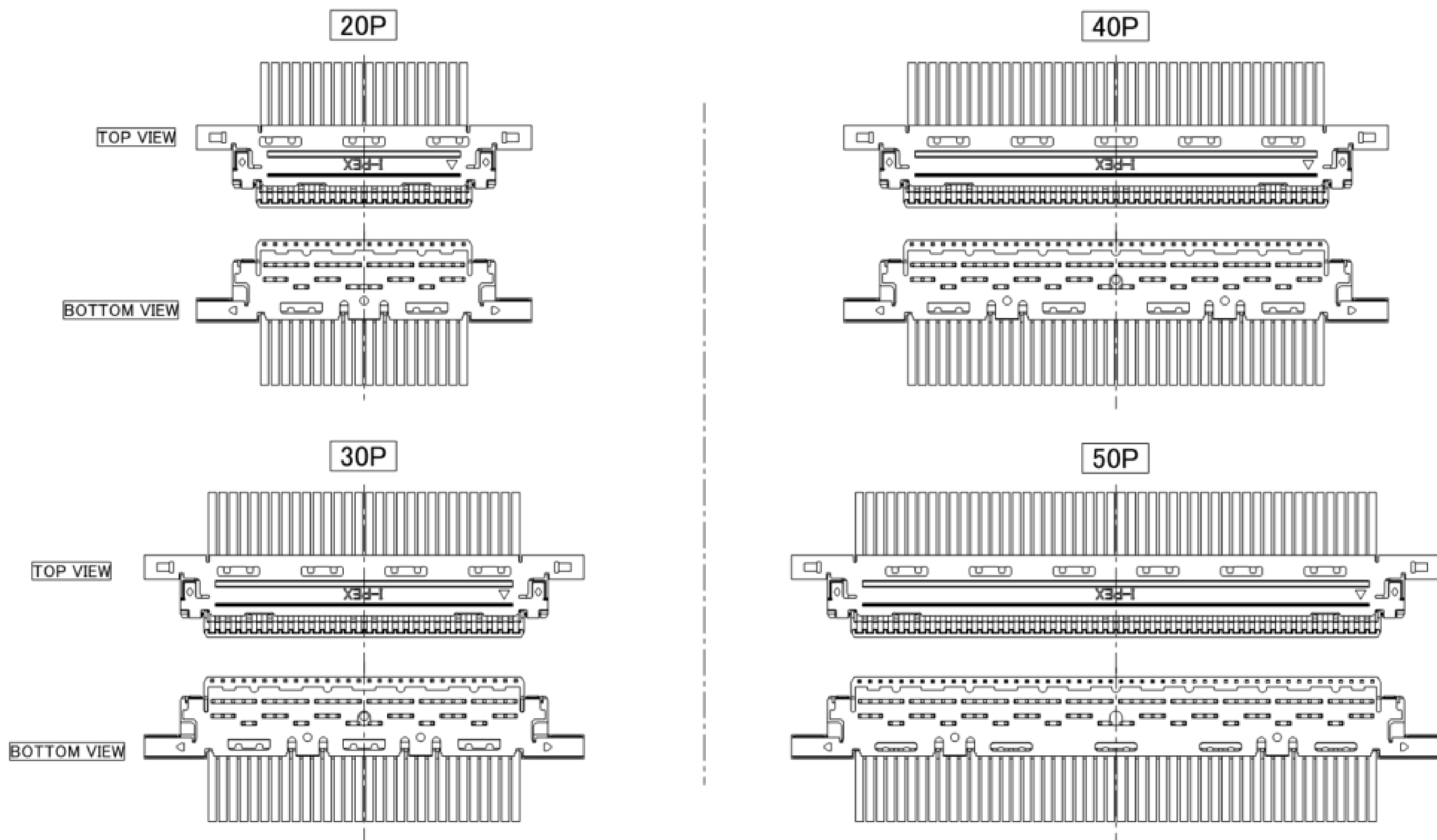

Rev.38

ITEMS	SPECIFICATION
APPLICABLE CABLE	MICRO-COAXIAL CABLE : AWG #44, 42, 40, 38, 36 DISCRETE WIRE : AWG #36, 34, 32 TWINAXIAL CABLE : AWG #40
RATED VOLTAGE	100V AC (PER CONTACT PIN) ※THIS IS THE RATED VOLTAGE OF THE CONNECTOR. PLEASE NOTE THAT THE RATED VOLTAGE MAY VARY IN THE HARNESS DEPENDING ON THE CABLES USED.
RATED CURRENT (FOR CONTACT)	0.1A AC/DC [AWG #44] PER CONTACT PIN/UP TO 50 CONTACTS 0.24A AC/DC [AWG #42] PER CONTACT PIN/UP TO 50 CONTACTS 0.3A AC/DC [AWG #40] PER CONTACT PIN/UP TO 50 CONTACTS 0.5A AC/DC [AWG #38] PER CONTACT PIN/UP TO 14 CONTACTS 0.8A AC/DC [AWG #36] PER CONTACT PIN/UP TO 10 CONTACTS 1.0A AC/DC [AWG #34] PER CONTACT PIN/UP TO 6 CONTACTS 1.0A AC/DC [AWG #32] PER CONTACT PIN/UP TO 6 CONTACTS TESTING BY A REAL MACHINE IS RECOMMENDED BECAUSE TEMPERATURE RISE MAY AFFECTED BY ACTUAL SITUATION.
OPERATING TEMPERATURE	23 TO 358K(-40°C TO +85°C)
OPERATING HUMIDITY	85% MAX.
CONTACT RESISTANCE	INITIAL : 140mohm MAX.(AWG #32) / AFTER TEST : \triangleleft40mohm MAX. 180mohm MAX.(AWG #34) 275mohm MAX.(AWG #36) 360mohm MAX.(AWG #38) 600mohm MAX.(AWG #40) 700mohm MAX.(AWG #42) 1080mohm MAX.(AWG #44)
GROUND SHELL RESISTANCE	INITIAL : 50mohm MAX. / AFTER TEST : \triangleleft40mohm MAX.
INSULATION RESISTANCE	INITIAL : 1000Mohm MIN. / AFTER TEST : 500Mohm MIN.
DIELECTRIC WITHSTANDING VOLTAGE	AC 250V 1min
DURABILITY	30 CYCLES
MATING FORCE (INITIAL / AFTER TEST)	20P : 9.45N MAX. 30P : 12.15N MAX. 40P : 16.20N MAX. 50P : 20.25N MAX.
UNMATING FORCE (INITIAL / AFTER TEST)	20P : 2.0N MIN. 30P : 3.0N MIN. 40P : 4.0N MIN. 50P : 5.0N MIN.
CABLE RETENTION FORCE	20P : 9.80N MIN. 30P : 14.70N MIN. 40P : 19.60N MIN. 50P : 24.50N MIN.
PRODUCT SPECIFICATION	PRS-1427
TEST REPORT	TR-08047 (20453-0**T-###) / TR-13084 (20453-2**T-###)
INSTRUCTION MANUAL	HIM-08004
ASSEMBLY MANUAL	ASM-08003
APPEARANCE CRITERIA No.	QLS-A***

Rev.38

Pull Bar

Recommended P/N		2576-1**-00	
PART NO.	Pos.	A	B
2576-#20-00	20	15.05	16.45
2576-#30-00	30	20.05	21.45
2576-#40-00	40	25.05	26.45
2576-#50-00	50	30.05	31.45

2576-0**-00

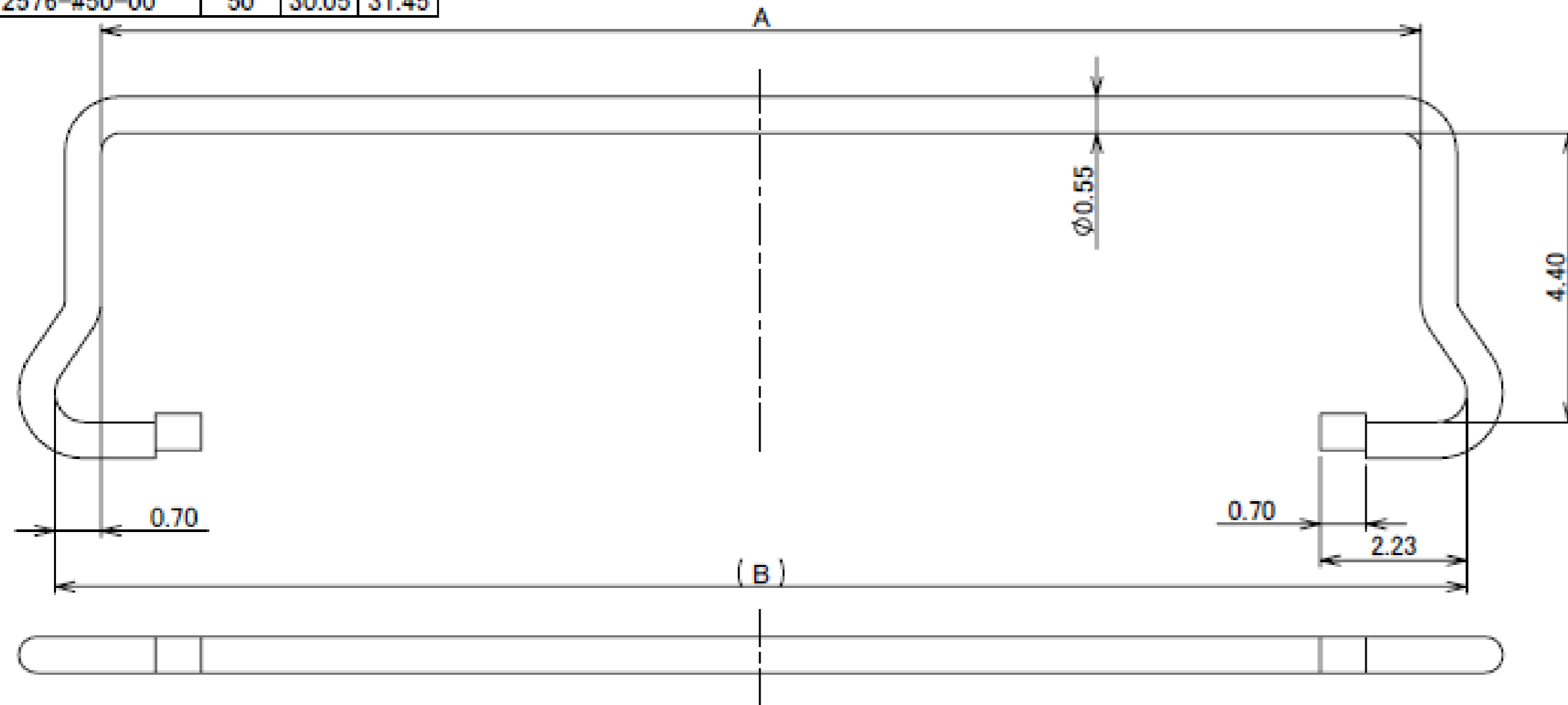

P/N: 2576-#**-00
 POS.
 0 : WITHOUT INSULATION COAT
 1 : WITH INSULATION COAT

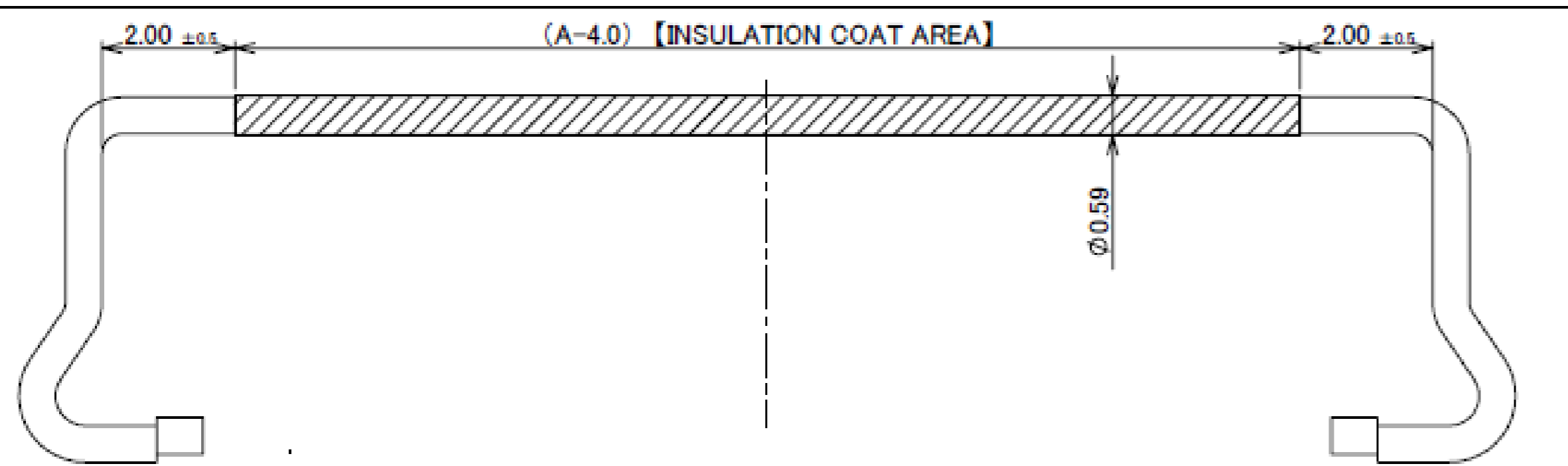

2576-1**-00

NO.	DISCRIPTION	MATERIAL	FINISH , REMARKS
1	PULL BAR	SUS	-

Rev.15

Shell-A

Recommended P/N		2574-0**2			
PART NO.	Pos.	A	B	C	D
2574-#20#	20	9.78	12.56	16.00	8.00 [= 4.0 × (3-1)]
2574-#30#	30	14.78	17.56	21.00	12.00 [= 4.0 × (4-1)]
2574-#40#	40	19.78	22.56	26.00	16.00 [= 4.0 × (5-1)]
2574-#50#	50	24.78	27.56	31.00	20.00 [= 4.0 × (6-1)]

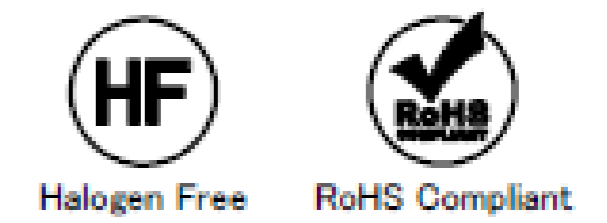

P/N:2574-#**#
 SEE TABLE.1
 Pos.
 0 : WITH DATUM MARK
 1 : WITHOUT DATUM MARK

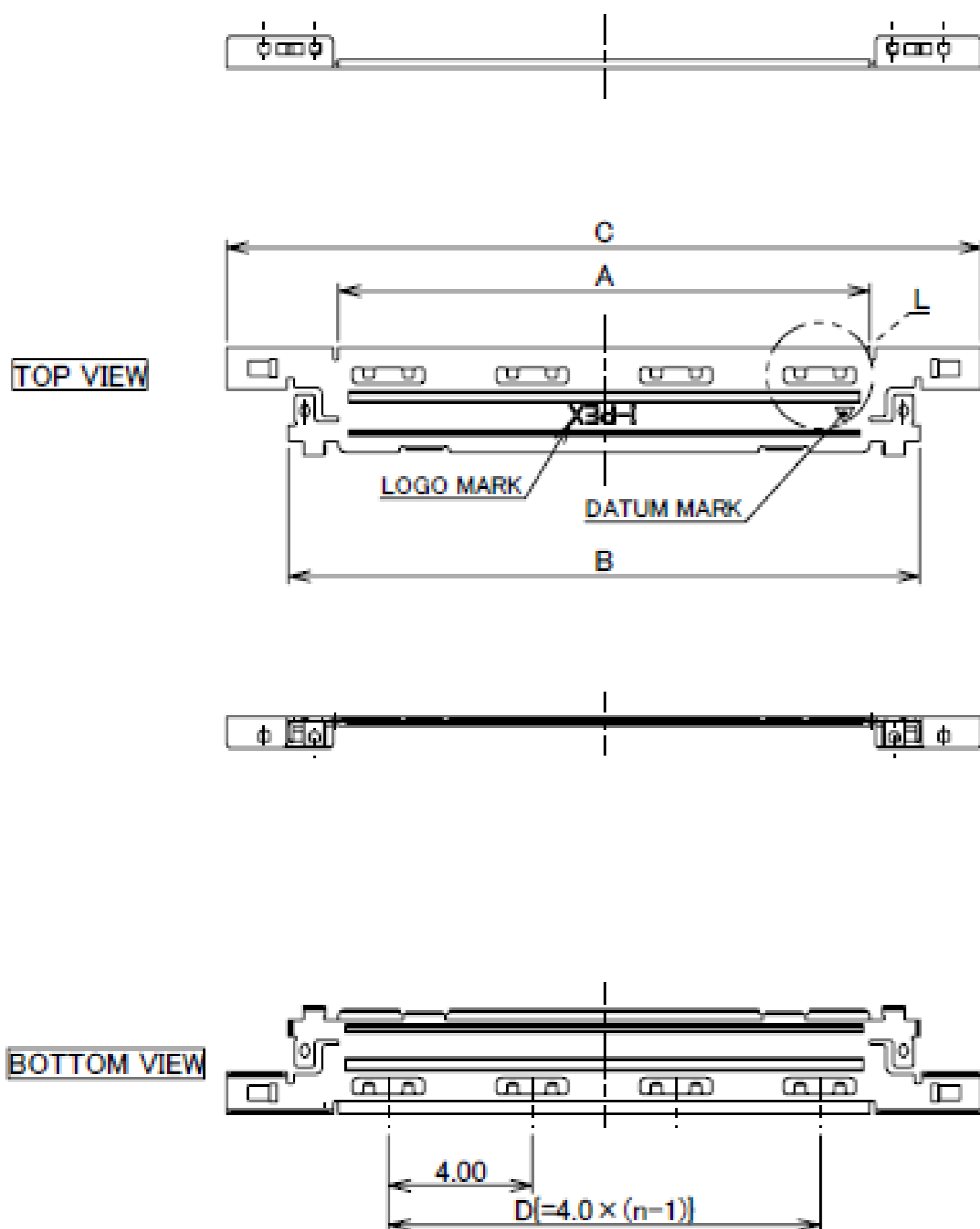
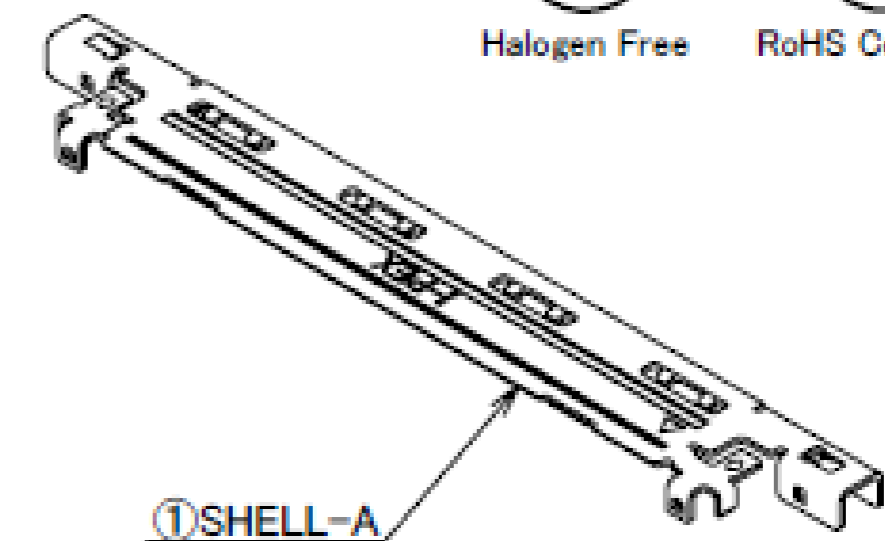

DETAIL L
S= 15:1

TABLE.1

PART NO.	SHELL-A FINISH
2574-***	TOP SIDE : Au 0.05 μm MIN. OVER Ni 1.00 μm MIN. BOTTOM SIDE : Au 0.075 μm MIN. OVER Ni 1.00 μm MIN.
2574-***2	TOP SIDE : Au 0.03 μm MIN. OVER Ni 1.00 μm MIN. BOTTOM SIDE : Ni 1.00 μm MIN. (THERE IS THE POSSIBILITY THAT Au ATTACHES RANDOMLY)

NO.	DISCRIPTION	MATERIAL	FINISH , REMARKS
1	SHELL A	PHOSPHOR BRONZE	SEE ABOVE TABLE.1

Rev.15

Receptacle Assembly

Recommended P/N		20455-0**E-76 (30P/40P/50P)					20455-A20E-76 (20P)	
PART NO.	Pos.	A	B	C	D	U		
20455-020E-#2	20	9.50	11.30	16.25	14.47	10.20		
20455-030E-##	30	14.50	16.30	21.25	19.47	15.20		
20455-040E-##	40	19.50	21.30	26.25	24.47	20.20		
20455-050E-##	50	24.50	26.30	31.25	29.47	25.20		

P/N:20455-0**E-##

SEE TABLE.1

Pos.



Halogen Free RoHS Compliant

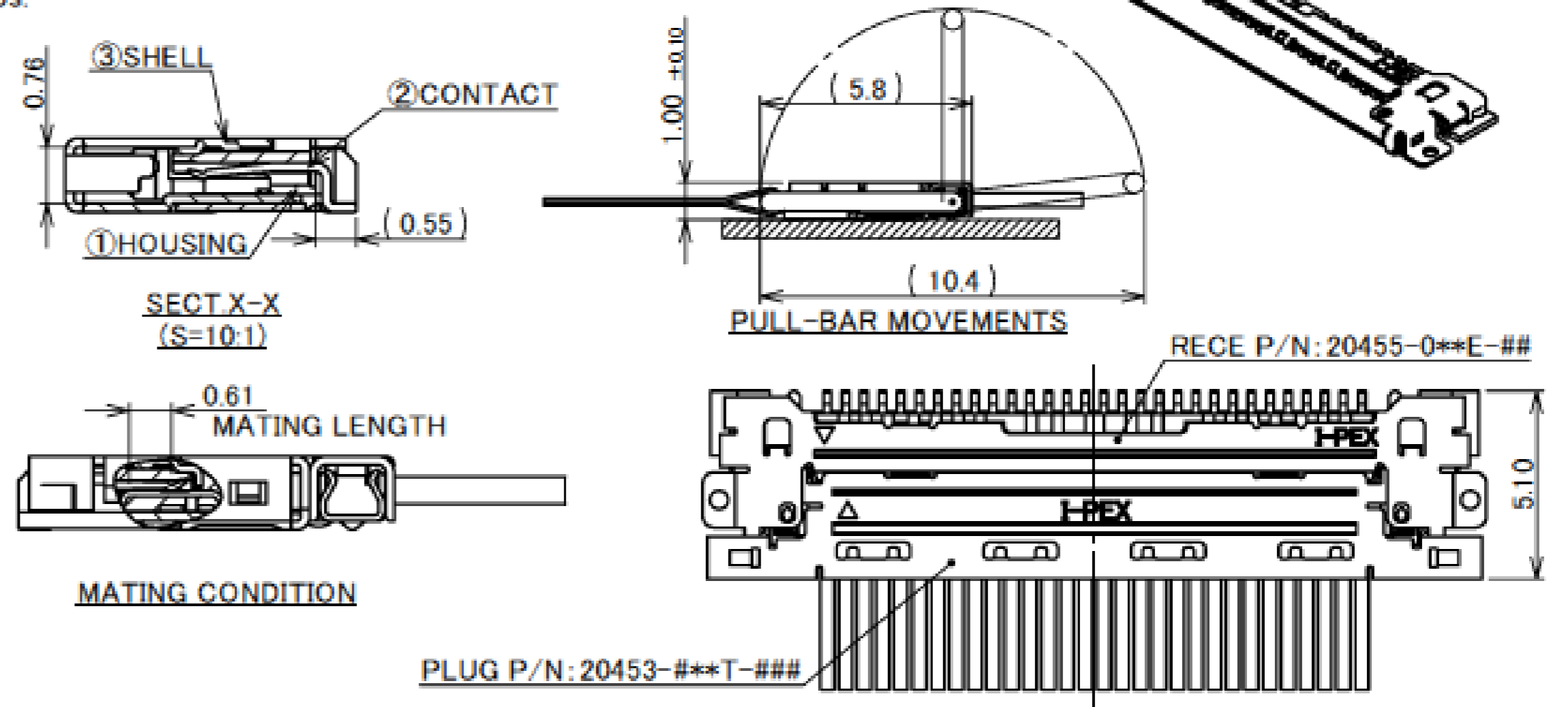
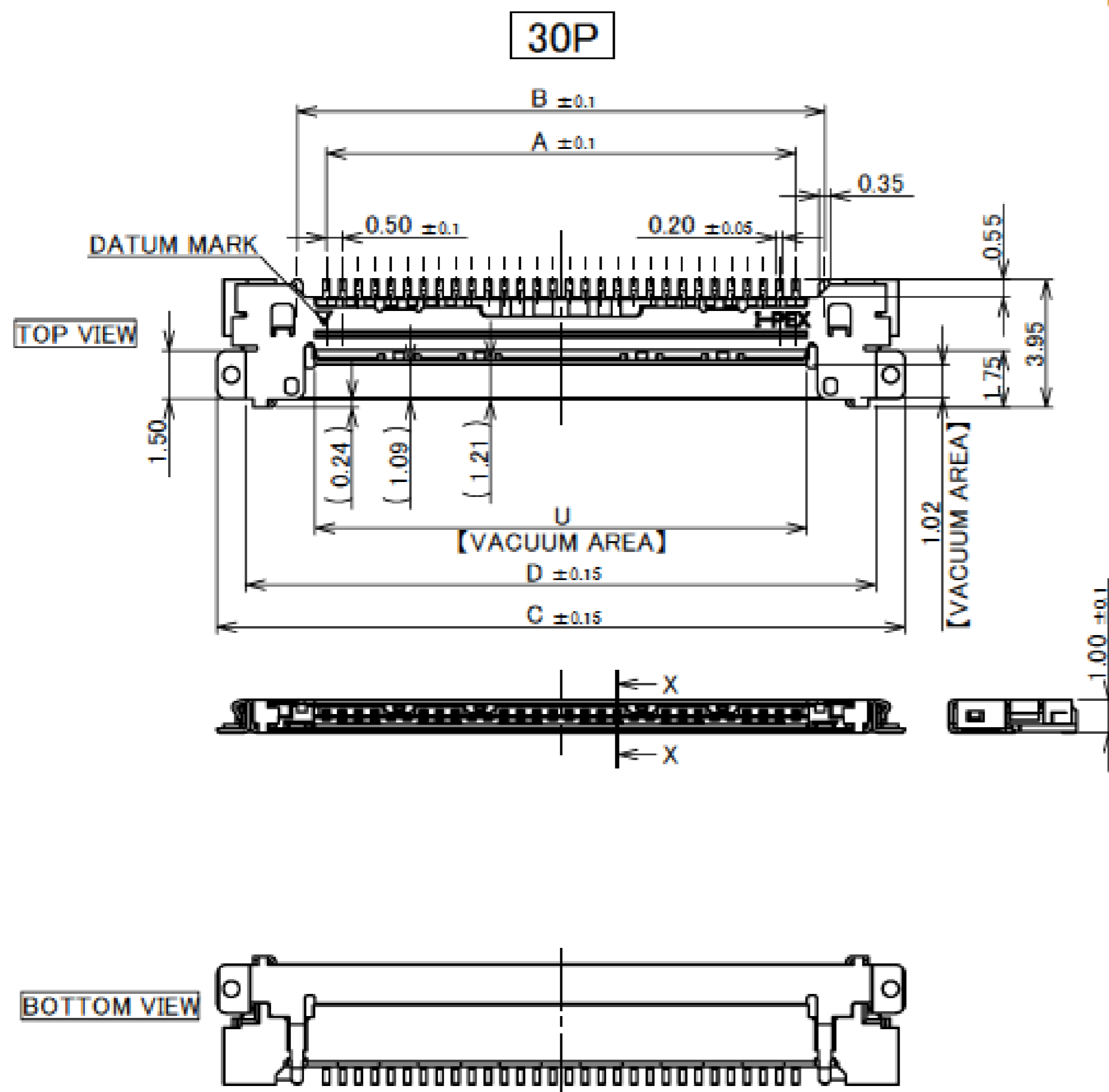
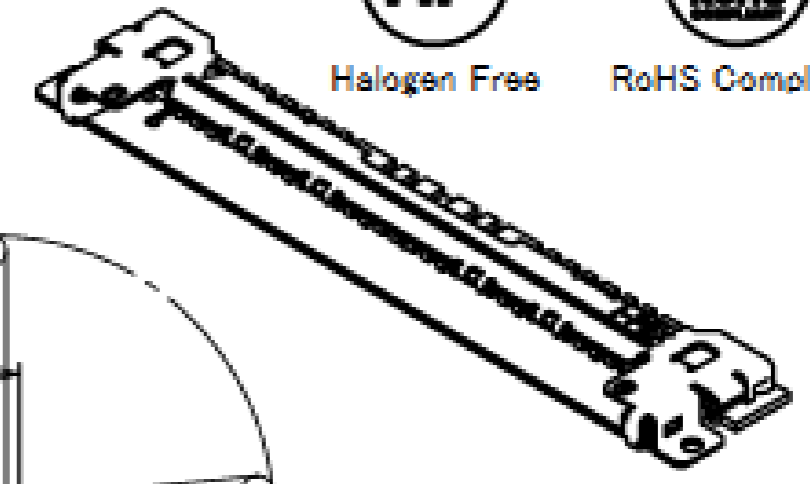

TABLE 1

PART NO.	DATUM MARK	CONTACT FINISH	SHELL FINISH
20455-0**E-02	WITH	CONTACT AREA Au 0.1 μm MIN. OVER Ni 1.00 μm MIN. SOLDERING AREA Au 0.05 μm MIN. OVER Ni 1.00 μm MIN.	Au 0.02 μm MIN. OVER Ni 1.00 μm MIN.
20455-0**E-12	WITHOUT	CONTACT AREA Au 0.1 μm MIN. OVER Ni 1.00 μm MIN. SOLDERING AREA Au 0.05 μm MIN. OVER Ni 1.00 μm MIN.	Au 0.01 μm MIN. OVER Ni 1.00 μm MIN.
20455-0**E-66	WITH	CONTACT AREA Au 0.1 μm MIN. OVER Ni 1.00 μm MIN. SOLDERING AREA Au 0.05 μm MIN. OVER Ni 1.00 μm MIN.	Au 0.01 μm MIN. OVER Ni 1.00 μm MIN.
20455-0**E-76	WITHOUT	CONTACT AREA Au 0.1 μm MIN. OVER Ni 1.00 μm MIN. SOLDERING AREA Au 0.05 μm MIN. OVER Ni 1.00 μm MIN.	Au 0.01 μm MIN. OVER Ni 1.00 μm MIN.

NO.	DISCRIPTION	MATERIAL	FINISH, REMARKS
3	SHELL	PHOSPHOR BRONZE	SEE ABOVE TABLE.1
2	CONTACT	PHOSPHOR BRONZE	SEE ABOVE TABLE.1
1	HOUSING	LCP	UL94V-0, BLACK

Rev.34

Recommended P/N		20455-0**E-76 (30P/40P/50P)					20455-A20E-76 (20P)	
PART NO.	Pos.	A	B	C	D	H	J	U
20455-A20E-##	20	9.50	11.30	16.25	14.47	15.32	15.84	10.20

P/N:20455-A20E-##

A: TYPE-A

SEE TABLE 2



Halogen Free RoHS Compliant

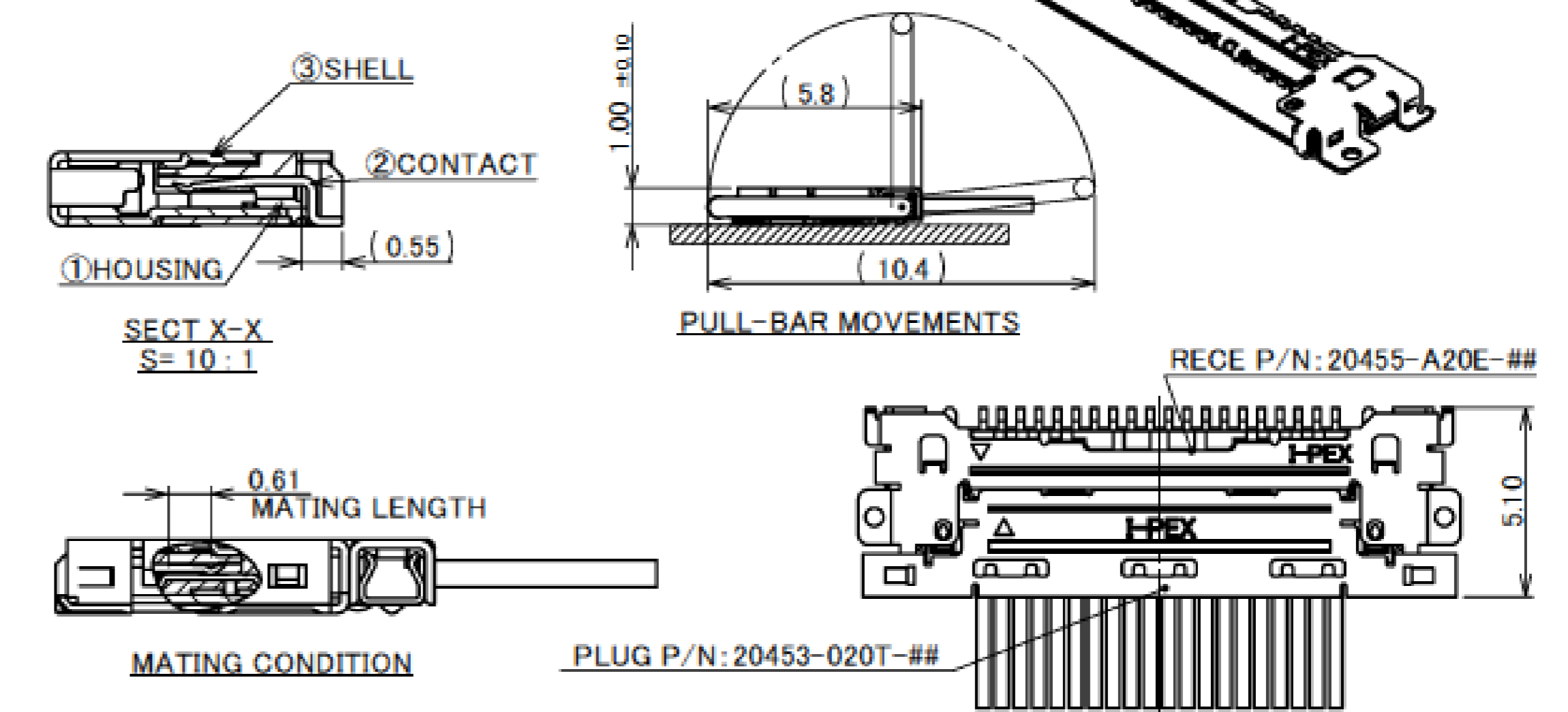
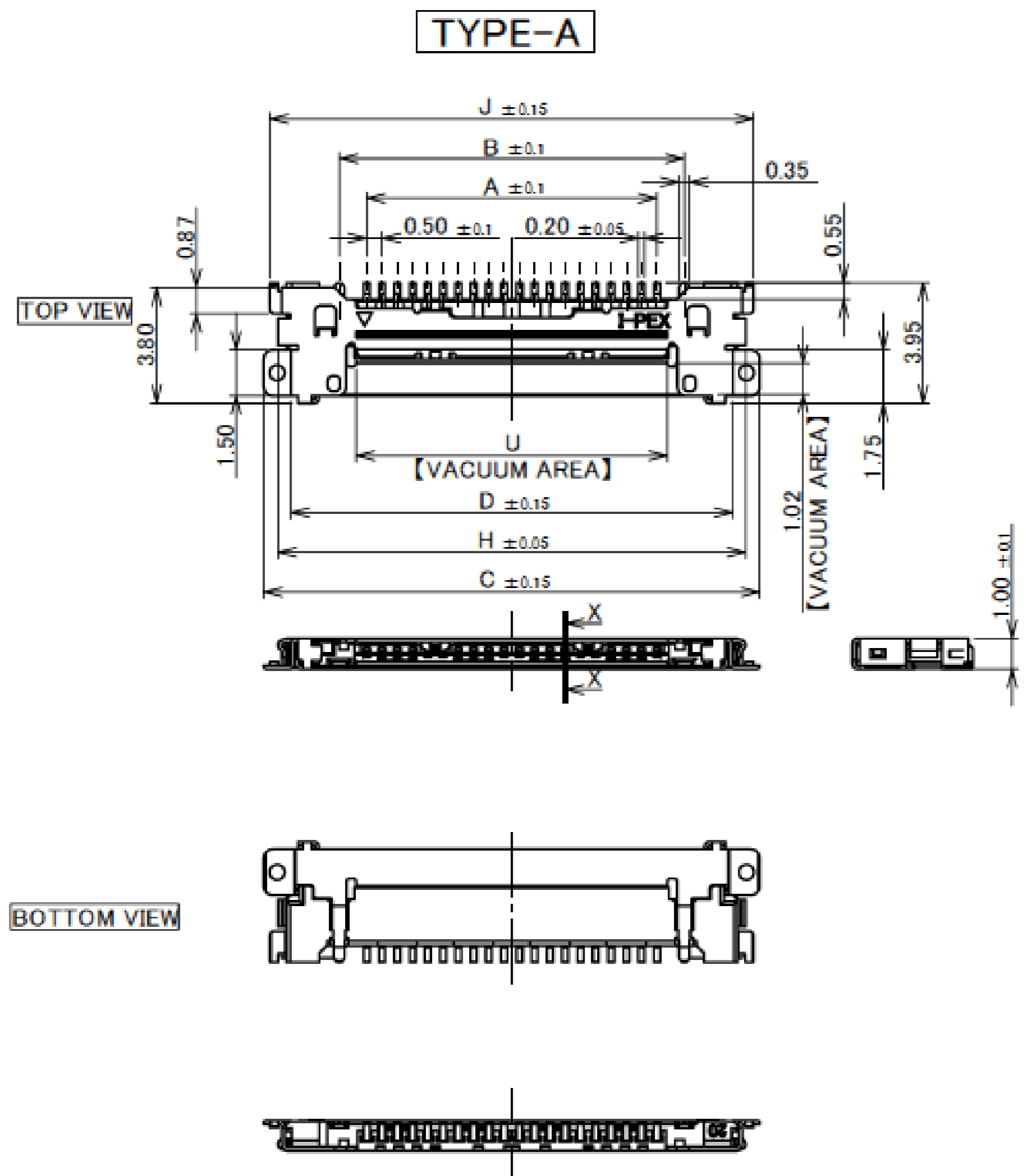
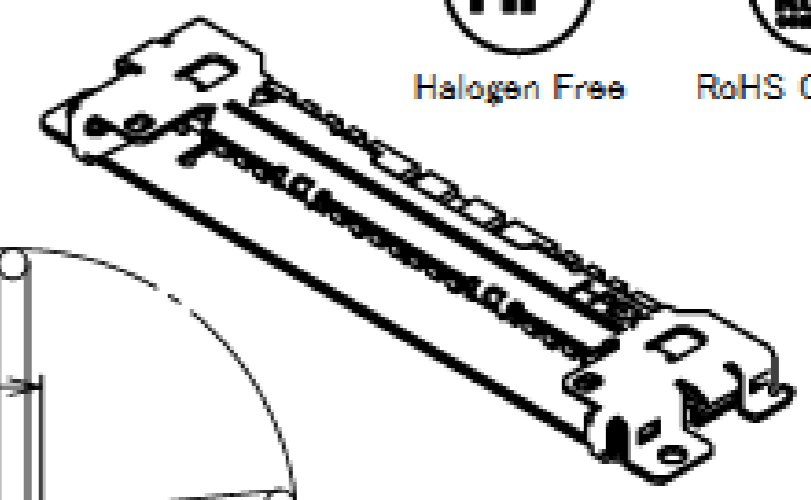

TABLE 2

PART NO.	DATUM MARK	CONTACT FINISH	SHELL FINISH
20455-A20E-02	WITH	CONTACT AREA Au 0.1 μm MIN. OVER Ni 1.00 μm MIN. SOLDERING AREA Au 0.05 μm MIN. OVER Ni 1.00 μm MIN.	Au 0.02 μm MIN. OVER Ni 1.00 μm MIN.
20455-A20E-12	WITHOUT	CONTACT AREA Au 0.1 μm MIN. OVER Ni 1.00 μm MIN. SOLDERING AREA Au 0.05 μm MIN. OVER Ni 1.00 μm MIN.	Au 0.01 μm MIN. OVER Ni 1.00 μm MIN.
20455-A20E-66	WITH	CONTACT AREA Au 0.1 μm MIN. OVER Ni 1.00 μm MIN. SOLDERING AREA Au 0.05 μm MIN. OVER Ni 1.00 μm MIN.	Au 0.01 μm MIN. OVER Ni 1.00 μm MIN.
20455-A20E-76	WITHOUT	CONTACT AREA Au 0.1 μm MIN. OVER Ni 1.00 μm MIN. SOLDERING AREA Au 0.05 μm MIN. OVER Ni 1.00 μm MIN.	Au 0.01 μm MIN. OVER Ni 1.00 μm MIN.

NO.	DISCRIPTION	MATERIAL	FINISH, REMARKS
3	SHELL	PHOSPHOR BRONZE	SEE ABOVE TABLE.1
2	CONTACT	PHOSPHOR BRONZE	SEE ABOVE TABLE.1
1	HOUSING	LCP	UL94V-0, BLACK

Rev.34

Receptacle Assembly

PART NO.	Pos.	A	B	E	F	G	H	J	K
20455-#20E-##	20	9.50	11.30	14.30	10.60	18.20	15.32	15.84	14.84
20455-#30E-##	30	14.50	16.30	19.30	15.60	23.20	-	-	-
20455-#40E-##	40	19.50	21.30	24.30	20.60	28.20	-	-	-
20455-#50E-##	50	24.50	26.30	29.30	25.60	33.20	-	-	-

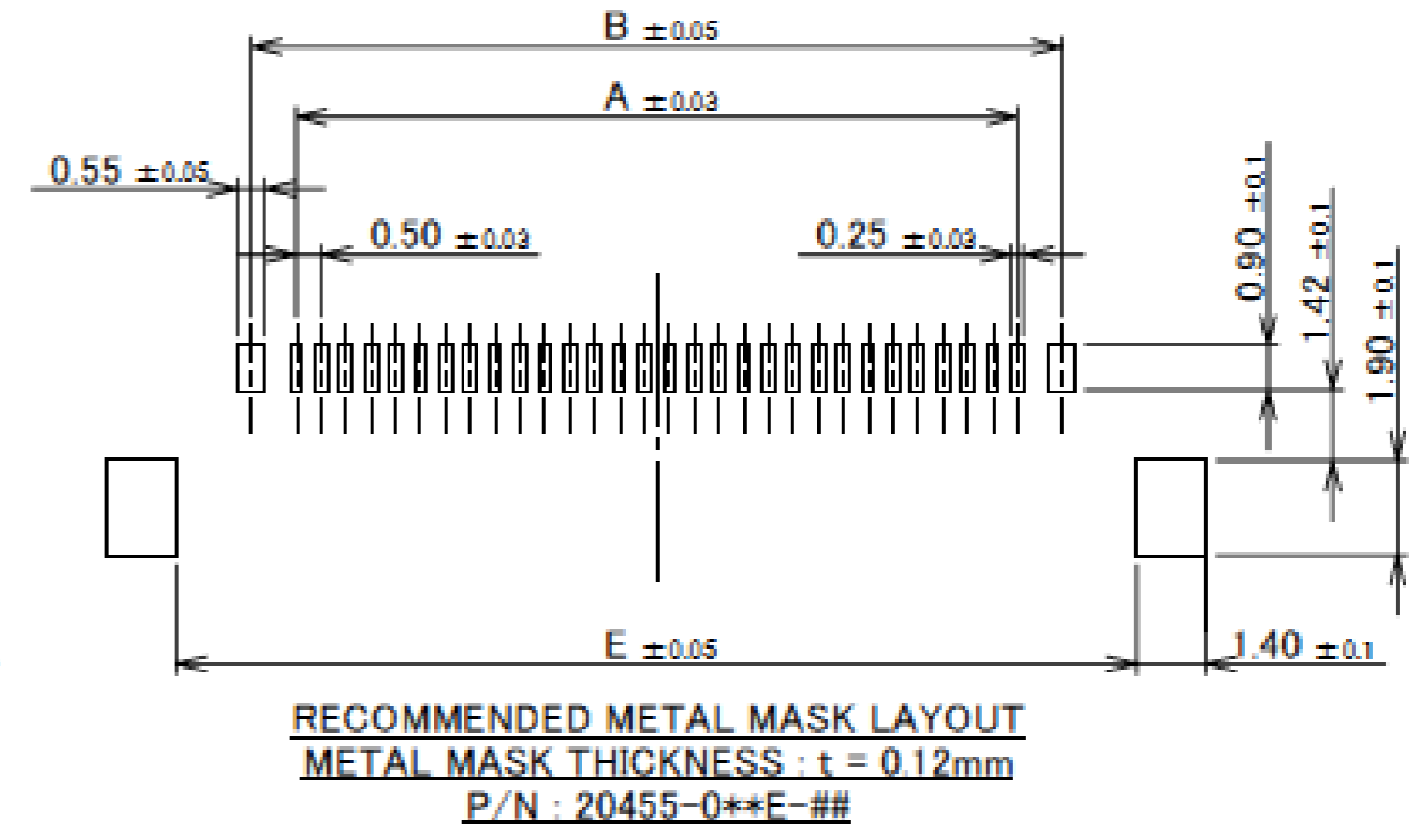
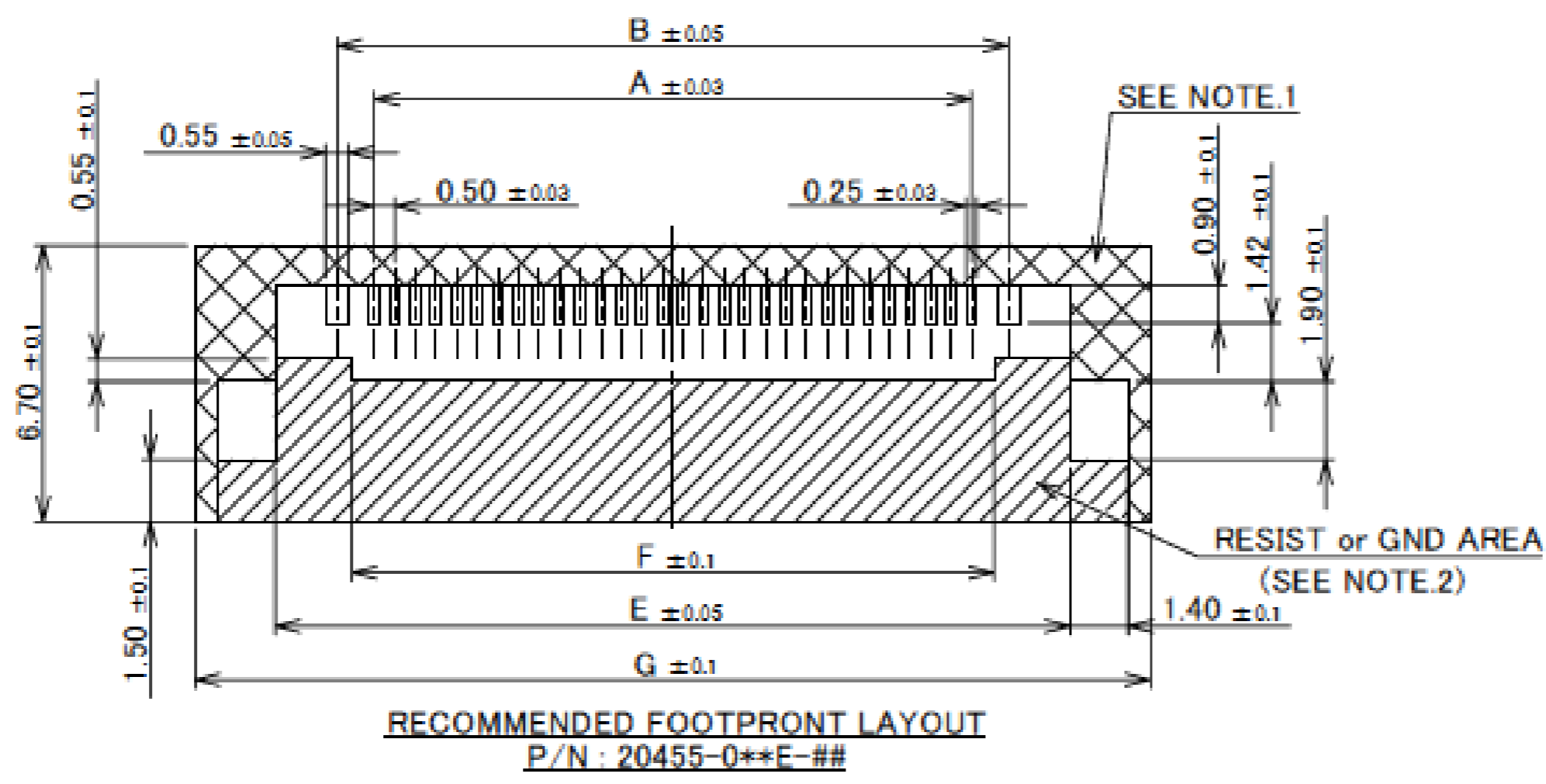

TYPE-A

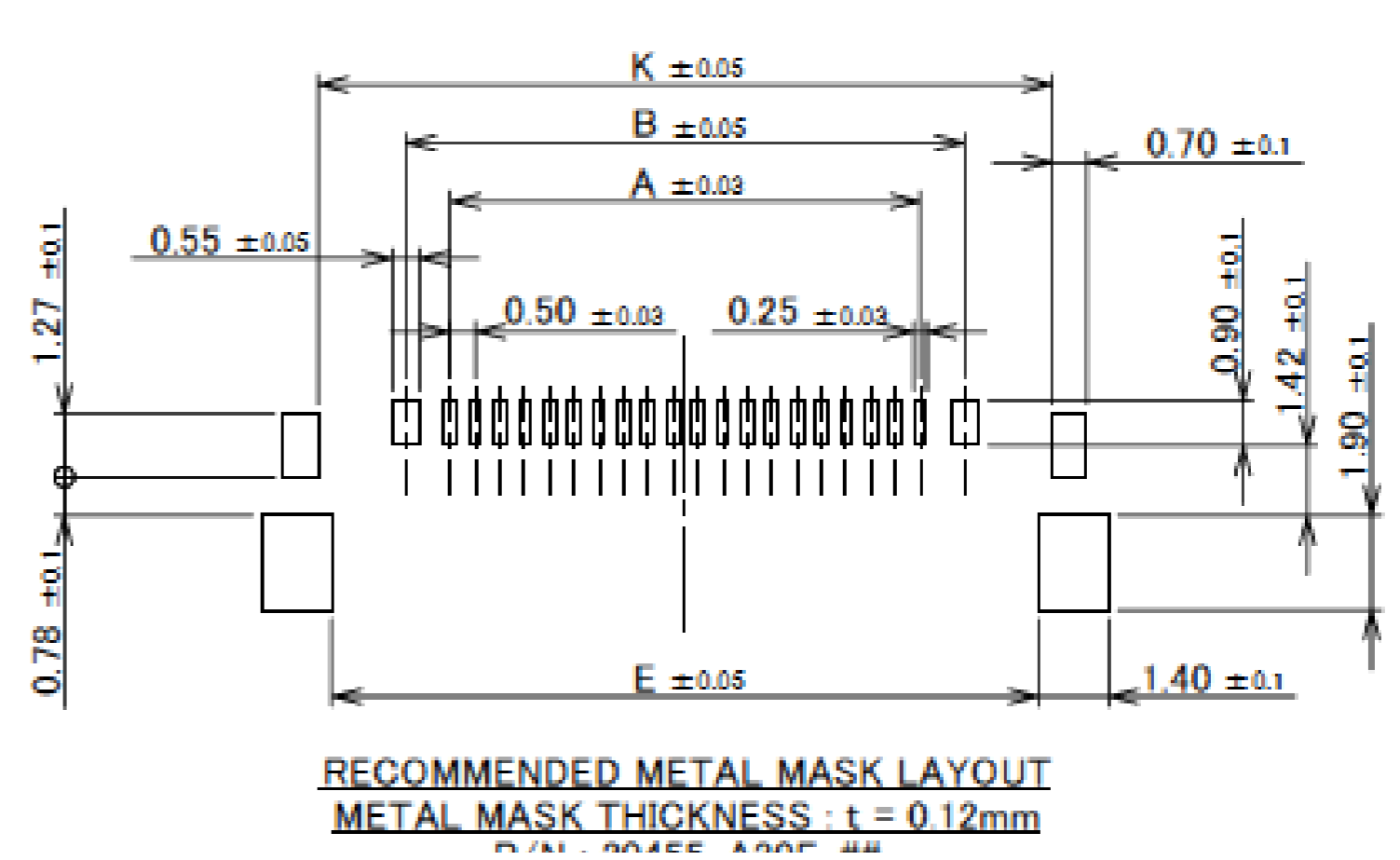
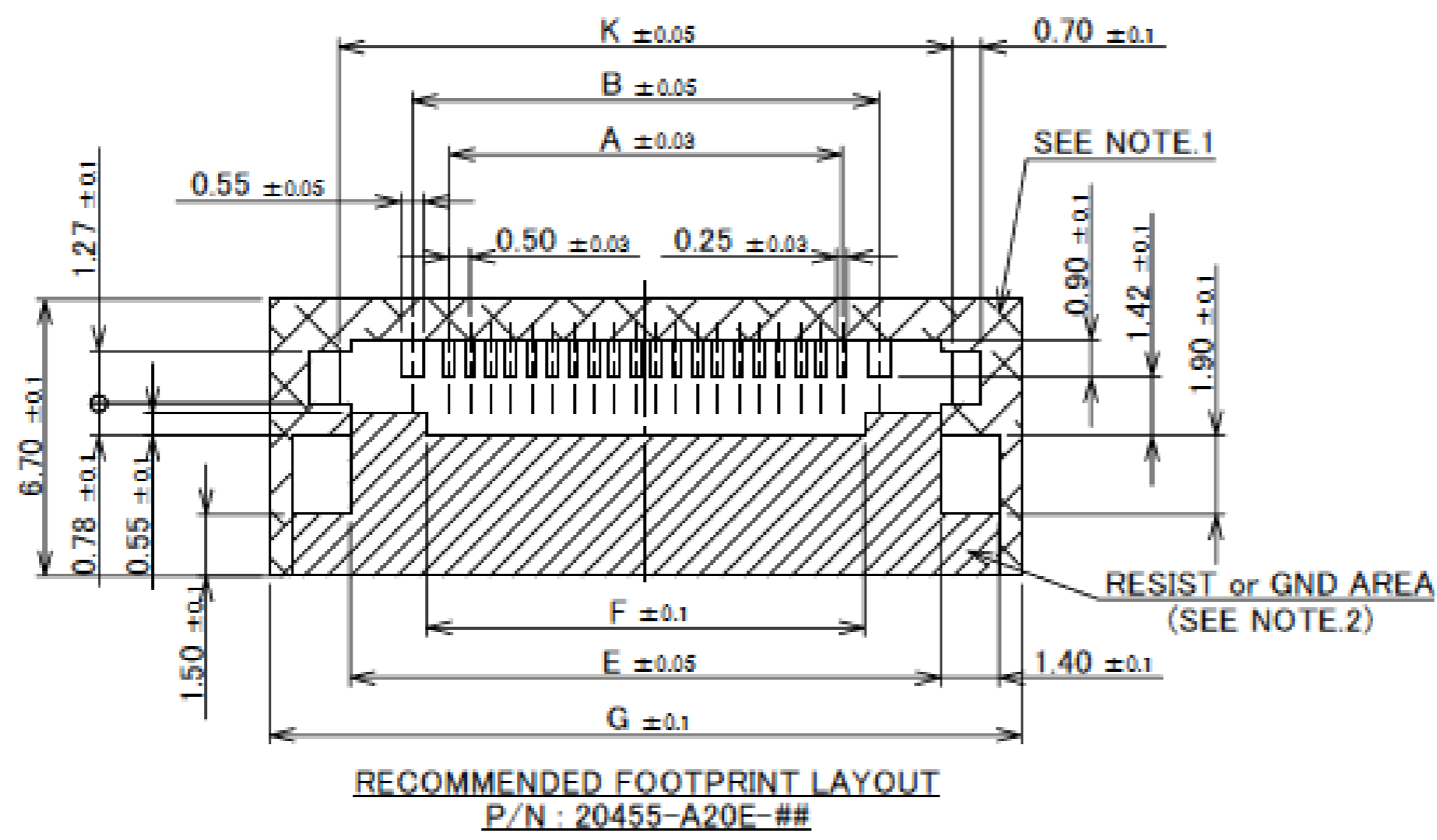

NOTES.

1. IN CASE OF PLUG WITH PULL-BAR, DO NOT MOUNT ANOTHER COMPONENT IN THIS AREA.
2. SOLDER RESIST MUST BE APPLIED TO THIS AREA.

Rev.34

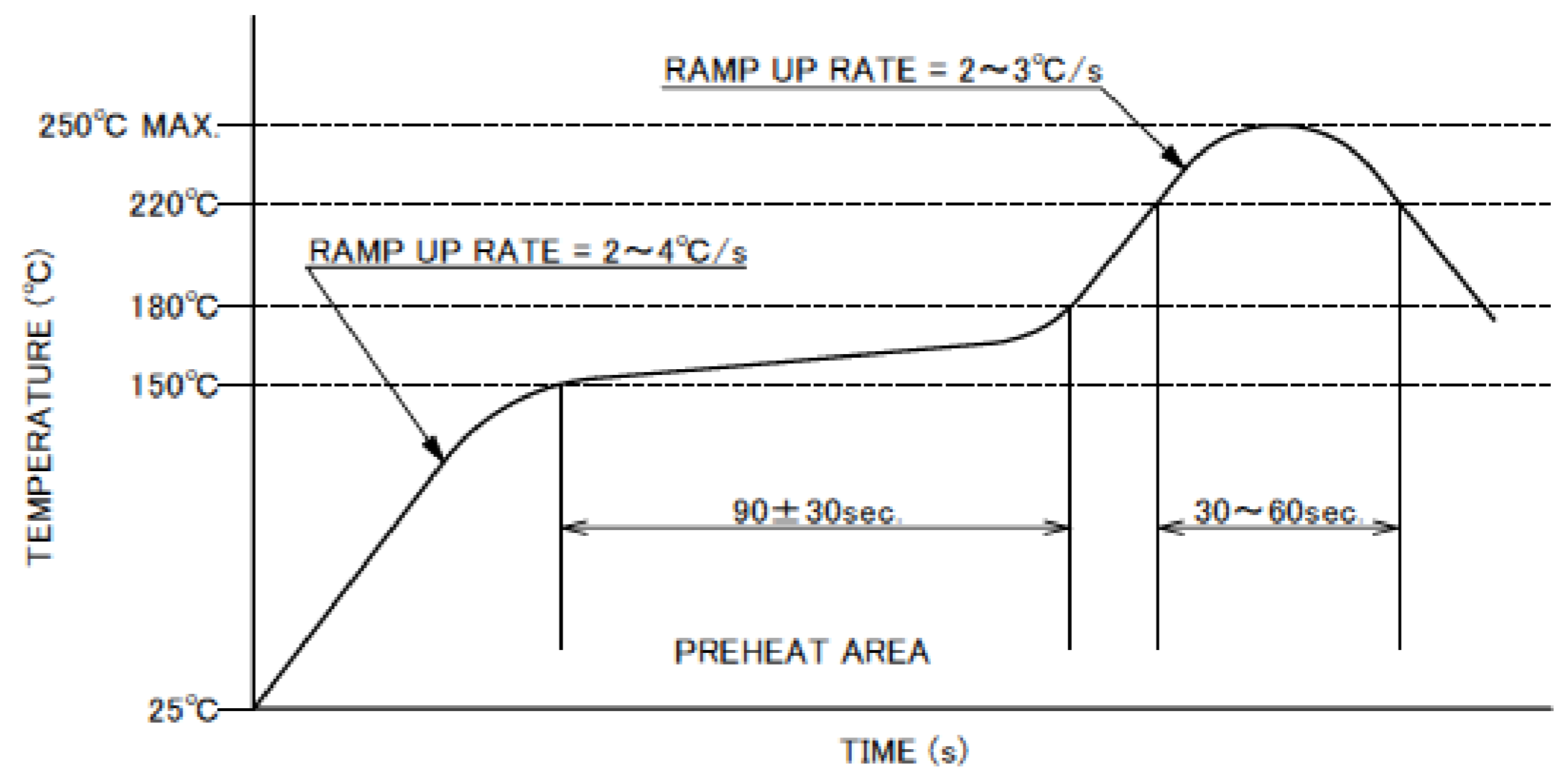
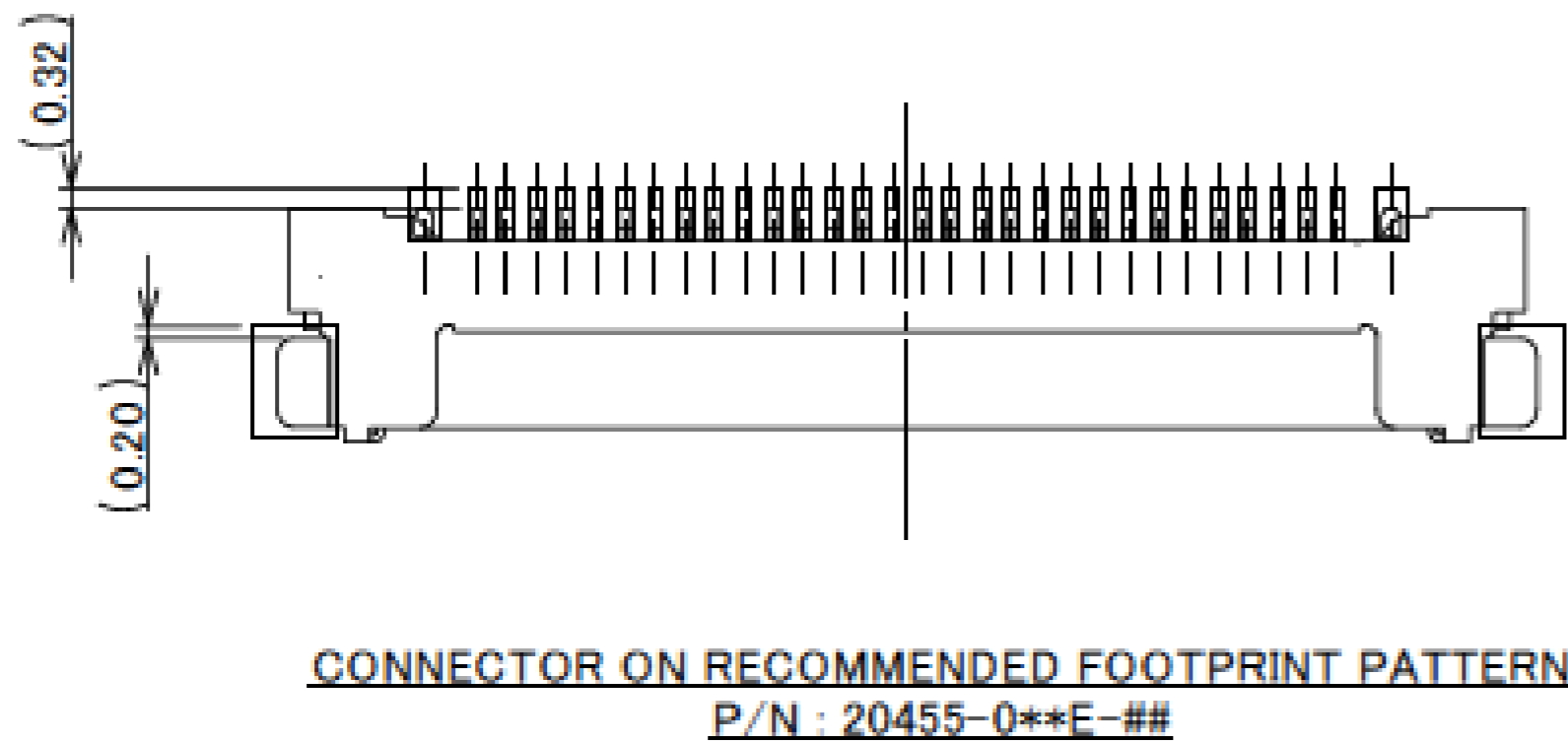

TYPE-A

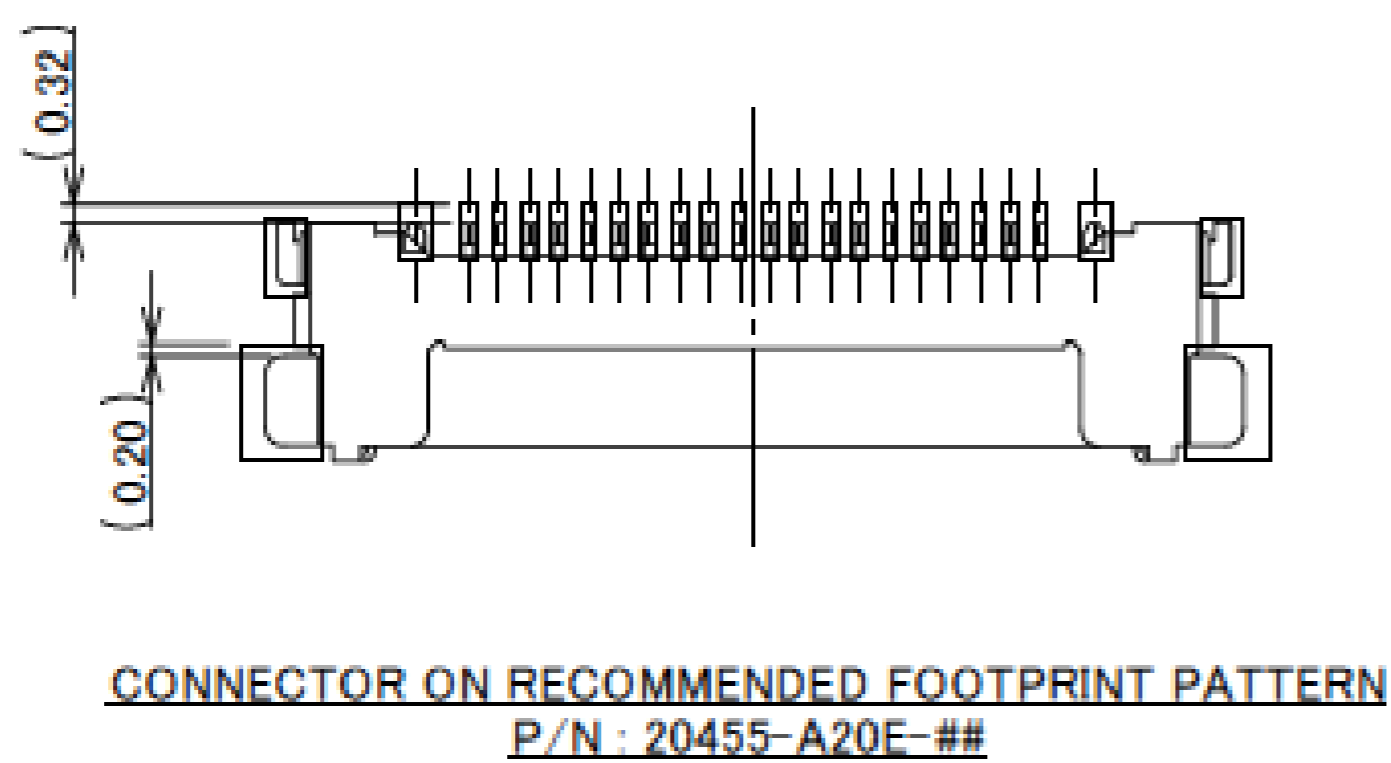

Rev.34

Receptacle Assembly

FOR CABLINE-VS PLUG CABLE ASSEMBLY (DWG NO. 20453)

ITEMS	SPECIFICATION
APPLICABLE CABLE	MICRO-COAXIAL CABLE : AWG #44, 42, 40, 38, 36 DISCRETE WIRE : AWG #36, 34, 32 TWINAXIAL CABLE : AWG #40
RATED VOLTAGE	100V AC (PER CONTACT PIN) ※THIS IS THE RATED VOLTAGE OF THE CONNECTOR. PLEASE NOTE THAT THE RATED VOLTAGE MAY VARY IN THE HARNESS DEPENDING ON THE CABLES USED.
RATED CURRENT (FOR CONTACT)	0.1A AC/DC [AWG #44] PER CONTACT PIN/UP TO 50 CONTACTS 0.24A AC/DC [AWG #42] PER CONTACT PIN/UP TO 50 CONTACTS 0.3A AC/DC [AWG #40] PER CONTACT PIN/UP TO 50 CONTACTS 0.5A AC/DC [AWG #38] PER CONTACT PIN/UP TO 14 CONTACTS 0.8A AC/DC [AWG #36] PER CONTACT PIN/UP TO 10 CONTACTS 1.0A AC/DC [AWG #34] PER CONTACT PIN/UP TO 6 CONTACTS 1.0A AC/DC [AWG #32] PER CONTACT PIN/UP TO 6 CONTACTS TESTING BY A REAL MACHINE IS RECOMMENDED BECAUSE TEMPURECHER RISE MAY AFFECTED BY ACTUAL SITUATION.
OPERATING TEMPERATURE	233 TO 358K(-40°C TO +85°C)
OPERATING HUMIDITY	85% R.H. MAX.
CONTACT RESISTANCE	INITIAL : 140mohm MAX.(AWG #32) / AFTER TEST : \triangleleft40mohm MAX. 180mohm MAX.(AWG #34) 275mohm MAX.(AWG #36) 360mohm MAX.(AWG #38) 600mohm MAX.(AWG #40) 700mohm MAX.(AWG #42) 1080mohm MAX.(AWG #44)
GROUND SHELL RESISTANCE	INITIAL : 50mohm MAX. / AFTER TEST : \triangleleft40mohm MAX.
INSULATION RESISTANCE	INITIAL : 1000Mohm MIN. / AFTER TEST : 500Mohm MIN.
DIELECTRIC WITHSTANDING VOLTAGE	AC250V 1min
DURABILITY	30 CYCLES
MATING FORCE (INITIAL / AFTER TEST)	20P : 9.45N MAX. 30P : 12.15N MAX. 40P : 16.20N MAX. 50P : 20.25N MAX.
UNMATING FORCE (INITIAL / AFTER TEST)	20P : 2.0N MIN. 30P : 3.0N MIN. 40P : 4.0N MIN. 50P : 5.0N MIN.
CABLE RETENTION FORCE	20P : 9.80N MIN. 30P : 14.70N MIN. 40P : 19.60N MIN. 50P : 24.50N MIN.
COPLANARITY	0.10 MAX.
PRODUCT SPECIFICATION	PRS-1427
TEST REPORT	TR-08047 (20455-***E-#2) TR-13084 (20455-***E-#6, 20455-0**E-#8)
PACKING STANDARD	300-643
INSTRUCTION MANUAL	HIM-08004
APPEARANCE CRITERIA NO.	QLS-A***

Rev.35

Custom Connectors Available

RF Connectors

MHF® series

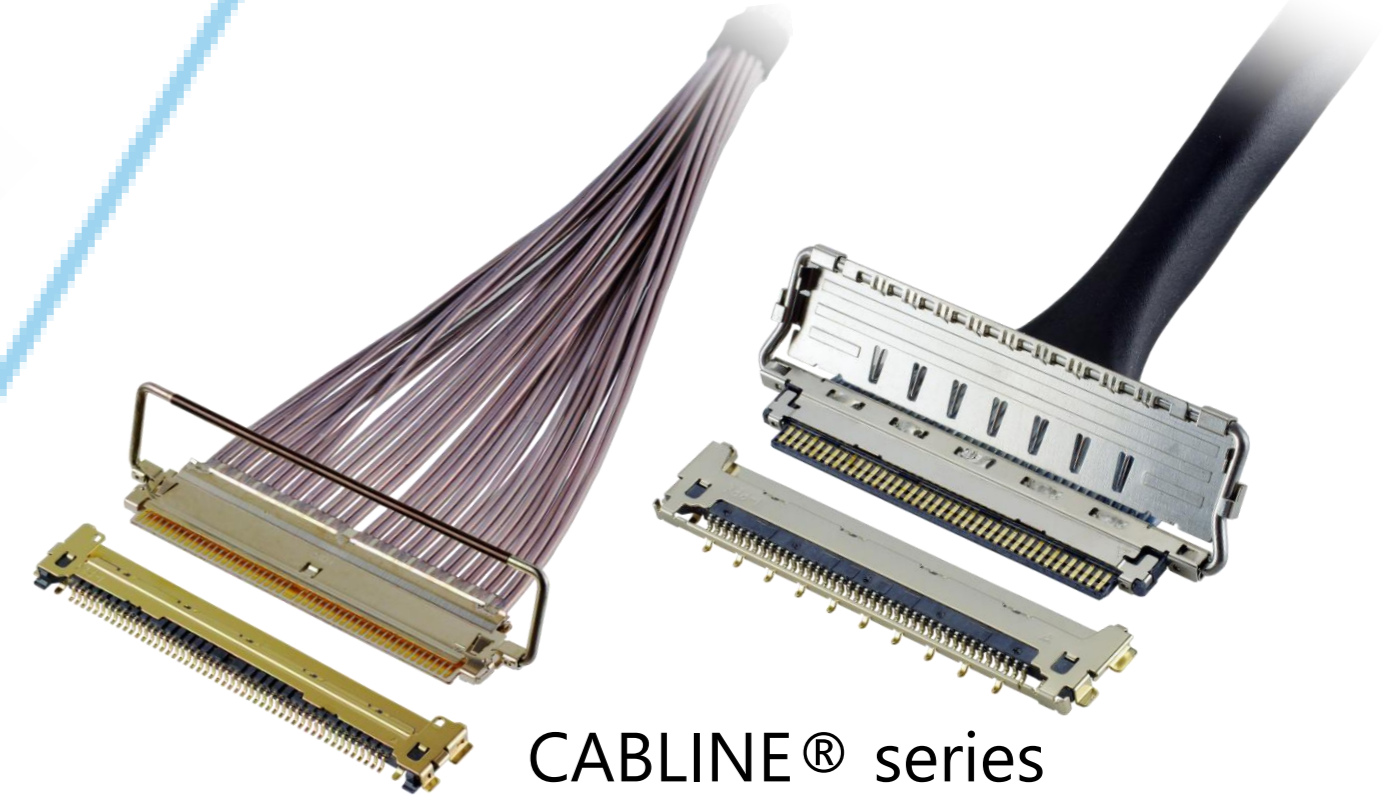

CABLINA® series

Micro-Coaxial/Twinaxial Connectors



Wire-to-Board Connectors/Terminals

AP series

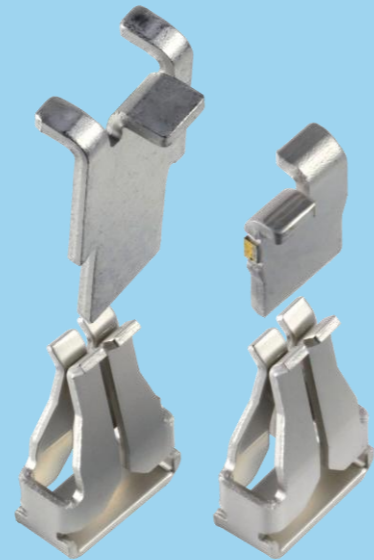

ISH® series

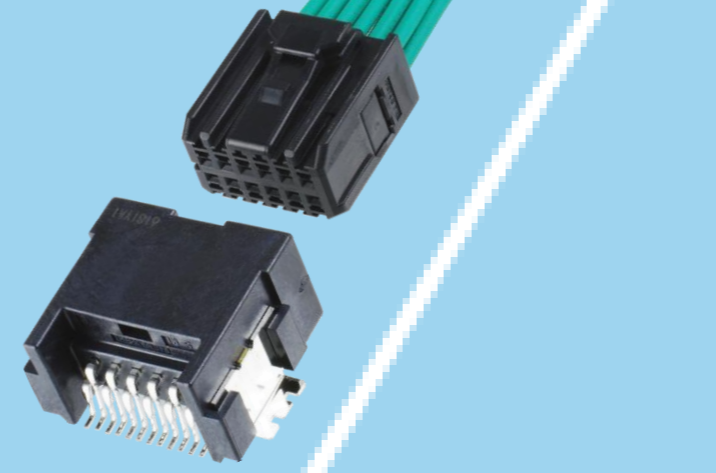

NOVASTACK® series



Board-to-Board Connectors



I/O Connectors

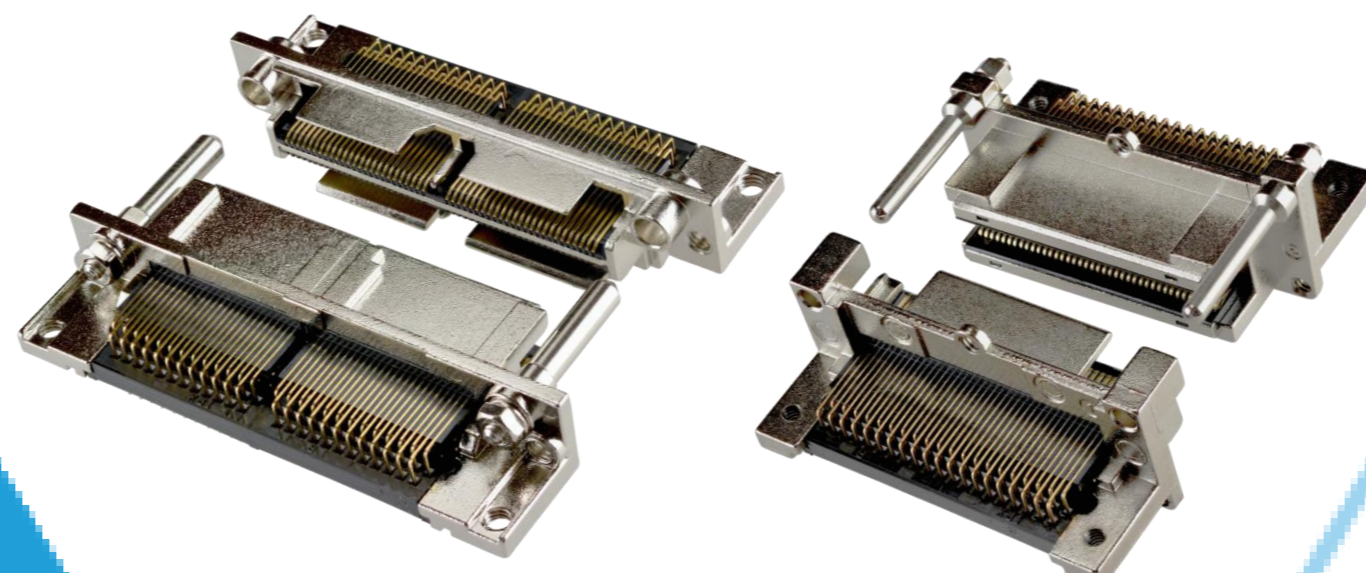

MINIDOCK™ series

MINIFLEX® series EVAFLEX® series

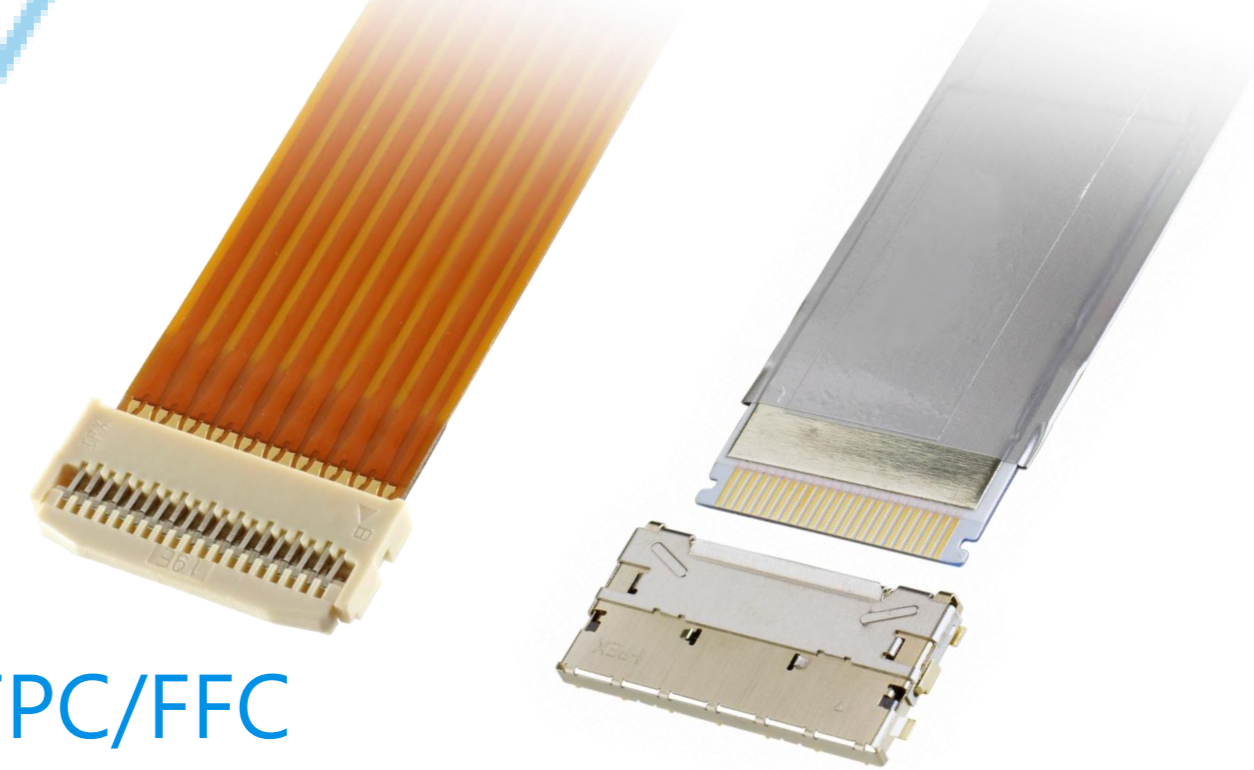

FPC/FFC Connectors



Inquiry



I-PEX, MHF, CABLINE, NOVASTACK, ISH, IARPB, MINIFLEX, EVAFLEX, MINIDOCK, i-Fit and ZenShield are registered trademarks of I-PEX Inc. Please note that the contents in the catalog might be changed without prior notification. I-PEX Inc. assumes no responsibility for any inaccuracies or obligation to update information on these documents. Please be sure to read and understand the latest "Precautions for Use" and "Instruction Manual" before you use our products. We shall not be responsible for any defects, damages or troubles in case you use our products without following the precautions for use. Please feel free to contact our sales representatives when you use our products for any applications that require very high reliability and safety, or that relate to human life (ex. nuclear power control, aerospace, transportation, medical equipment, safety equipment etc.).

Contact your sales representative or more detailed information.

www.i-pex.com

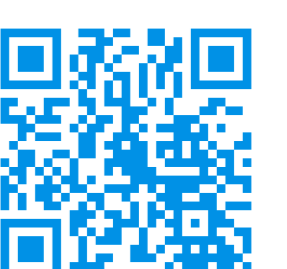

I-PEX

© I-PEX Inc. 2026
All rights reserved