



MP3320N

3-Channel, Charge Pump RGB LED Driver

DESCRIPTION

The MP3320N is a 3-channel RGB LED driver, with a wide 1.8V to 5.5V input voltage (V_{IN}) range. The maximum current for each channel is up to 100mA.

The MP3320N integrates a self-adaptive charge pump block, and the maximum output voltage (V_{OUT}) is up to 5.5V.

The device supports separated pulse-width modulation (PWM) dimming with an external PWM signal input for each LED channel. It also supports internal, customized, default LED current amplitude function.

To ensure system reliability, the MP3320N integrates rich protection features, including LED open protection, LED short protection, over-voltage protection (OVP), and over-temperature protection (OTP).

The MP3320N is available in a QFN-14 (2mmx2mm) package.

FEATURES

- 1.8V to 5.5V Input Voltage (V_{IN}) Range
- 5.5V Max Output Voltage (V_{OUT})
- 3 Channels, Max 100mA/Channel
- Internal, Self-Adaptive Charge Pump
- 1x, 1.5x, or 2x Charge Pump Auto-Transfer Rate
- 8-Bit Customized Default LED Current Amplitude for Each Channel
- Separated Pulse-Width Modulation (PWM) Dimming for Each Channel
- High Efficiency
- LED Open Protection
- LED Short Protection
- Over-Temperature Protection (OTP) in Hiccup Mode
- Available in a QFN-14 (2mmx2mm) Package

APPLICATIONS

- Wearable Devices
- LED Indicators
- Smart and Intelligent Devices

All MPS parts are lead-free, halogen-free, and adhere to the RoHS directive. For MPS green status, please visit the MPS website under Quality Assurance. "MPS", the MPS logo, and "Simple, Easy Solutions" are trademarks of Monolithic Power Systems, Inc. or its subsidiaries.

TYPICAL APPLICATION

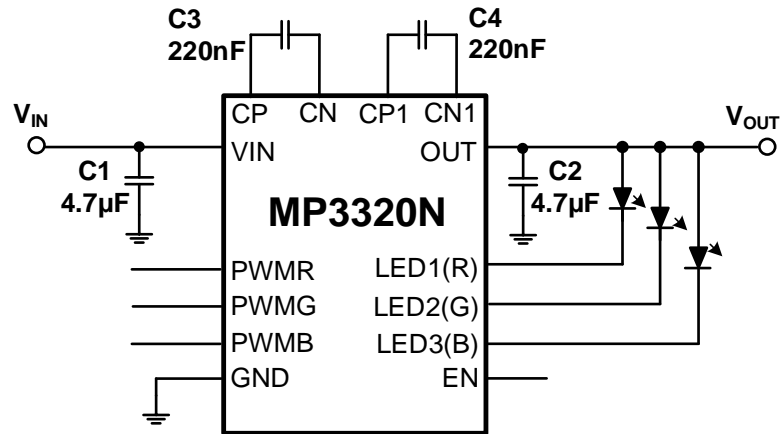

ORDERING INFORMATION

Part Number*	Package	Top Marking	MSL Rating
MP3320NGG	QFN-14 (2mmx2mm)	See Below	1

* For Tape & Reel, add suffix -Z (e.g. MP3320NGG-Z).

TOP MARKING

NNY
LLLL

NN: Product code
Y: Year code
LLLL: Lot number

PACKAGE REFERENCE

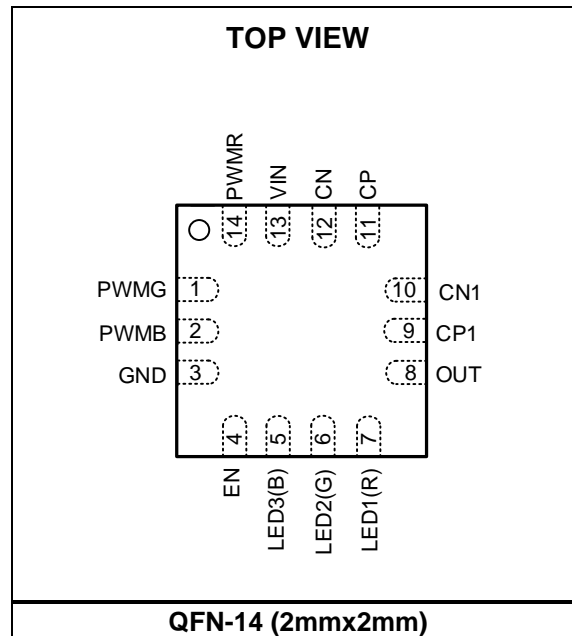

PIN FUNCTIONS

Pin #	Name	Description
1	PWVG	Input PWM dimming signal for LEDG (LED string 2).
2	PWVB	Input PWM dimming signal for LEDB (LED string 3).
3	GND	Ground.
4	EN	IC enable pin.
5	LED3(B)	LED string 3 current input pin. Connect the LED string 3 cathode to this pin.
6	LED2(G)	LED string 2 current input pin. Connect the LED string 2 cathode to this pin.
7	LED1(R)	LED string 1 current input pin. Connect the LED string 1 cathode to this pin.
8	OUT	Charge pump output pin.
9	CP1	Charge pump flying capacitor terminal 1.
10	CN1	Charge pump flying capacitor terminal 2.
11	CP	Charge pump flying capacitor terminal 3.
12	CN	Charge pump flying capacitor terminal 4.
13	VIN	Input power supply pin. Place a bypass capacitor close to the VIN pin.
14	PWVR	Input PWM dimming signal for LEDR (LED string 1).

ABSOLUTE MAXIMUM RATINGS ⁽¹⁾

All pins	-0.3V to +6V
Junction temperature (T _J)	150°C
Lead temperature	260°C
Storage temperature	-65°C to +150°C
Continuous power dissipation (T _A = 25°C) ⁽²⁾	
QFN-14 (2mmx2mm)	1.56W

ESD Ratings

Human body model (HBM)	±2kV
Charged-device model (CDM)	±2kV

Recommended Operating Conditions ⁽³⁾

Supply voltage (V _{IN})	1.8V to 5.5V
LED load	<5V
Operating junction temp (T _J)	-40°C to +125°C

Thermal Resistance ⁽⁴⁾	θ_{JA}	θ_{JC}
QFN-14 (2mmx2mm)	80	16...°C/W

Notes:

- 1) Exceeding these ratings may damage the device.
- 2) The maximum allowable power dissipation is a function of the maximum junction temperature T_J (MAX), the junction-to-ambient thermal resistance θ_{JA}, and the ambient temperature T_A. The maximum allowable continuous power dissipation at any ambient temperature is calculated by P_D (MAX) = (T_J (MAX) - T_A) / θ_{JA}. Exceeding the maximum allowable power dissipation can cause excessive die temperature, and the regulator may go into thermal shutdown. Internal thermal shutdown circuitry protects the device from permanent damage.
- 3) The device is not guaranteed to function outside of its operating conditions.
- 4) Measured on a JESD51-7, 4-layer PCB.

ELECTRICAL CHARACTERISTICS

$V_{IN} = 3.7V$, $T_J = 25^{\circ}C$, unless otherwise noted.

Parameters	Symbol	Condition	Min	Typ	Max	Units
Input Supply						
Operating input voltage	V_{IN}		1.8		5.5	V
Shutdown supply current	I_{SD}	$V_{IN} = 5.5V$, $V_{EN} = 0V$			1	μA
Quiescent supply current	I_Q	$V_{IN} = 3.7V$, pull EN high, no switching			1.5	mA
V_{IN} under-voltage lockout (UVLO) threshold	V_{IN_UVLO}	Rising edge			1.8	V
V_{IN} UVLO hysteresis				110		mV
Charge Pump Block						
Switching frequency	f_{SW}		0.9	1	1.1	MHz
MOSFET on resistance	$R_{DS(ON)}$	$V_{IN} = 2.5V$		1		Ω
LED Current Regulation						
Input high threshold for the EN and PWM/PWMG/PWMB pins	V_{EN/PWM_HI}	$V_{EN/PWM}$ rising	2			V
Input low threshold for the EN and PWM/PWMG/PWMB pins	V_{EN/PWM_LO}	$V_{EN/PWM}$ falling			0.5	V
LED current accuracy	I_{LED}	$I_{LED} = 100mA$	97	100	103	mA
		$I_{LED} = 50mA$	48.5	50	51.5	mA
LED current matching ⁽⁵⁾		$I_{LED} = 50mA$		1		%
LED regulation headroom voltage	V_{HD}	$I_{LED} = 100mA$		400		mV
Protection						
LED short protection threshold	V_{SLP}		3.3	3.5	3.7	V
LED short protection delay time	t_{SLP}			24		ms
LED open protection threshold	V_{LED_UVP}		50	80	110	mV
LED open protection delay time	t_{OLP}			24		ms
Over-voltage protection (OVP) threshold	V_{OVP}	Rising edge	5	5.5	6	V
OVP hysteresis		Hysteresis		500		mV
Over-temperature protection (OTP) threshold ⁽⁶⁾	T_{ST}	Rising edge		150		$^{\circ}C$
	T_{ST_HYS}	Hysteresis		25		$^{\circ}C$

Notes:

- 5) Matching is defined as the difference between the maximum current and minimum current, divided by 2 times the average current.
 6) Not tested in production. Guaranteed by characterization.

TYPICAL PERFORMANCE CHARACTERISTICS

$V_{IN} = 3.3V$, RGB LED load, 50mA/channel, $f_{SW} = 1MHz$, $T_A = 25^{\circ}C$, unless otherwise noted.

Steady State

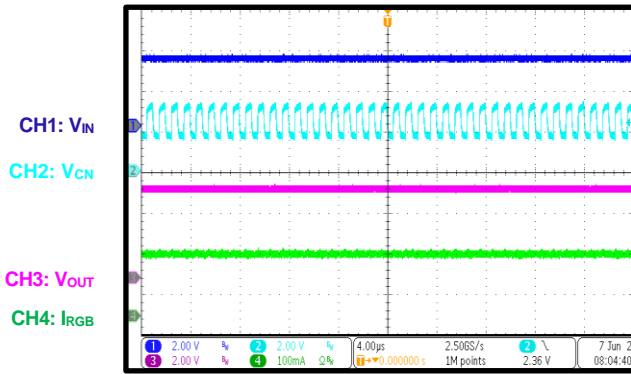

Steady State

V_{IN} changes from 4.3V to 3.3V to 2.3V

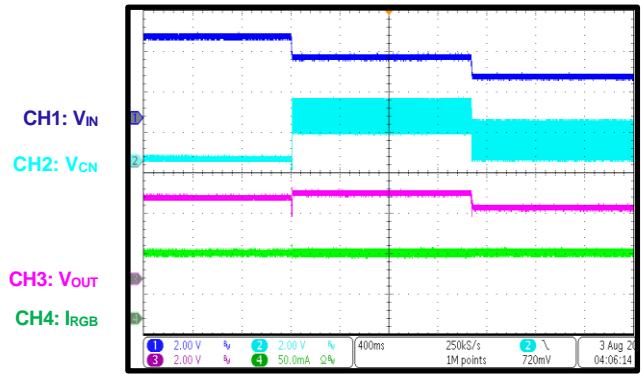

Start-Up through VIN

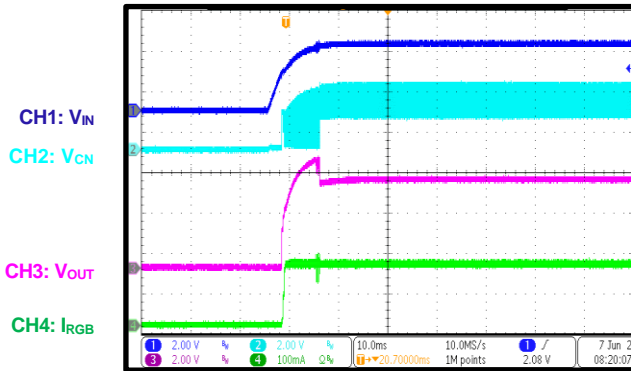

Shutdown through VIN

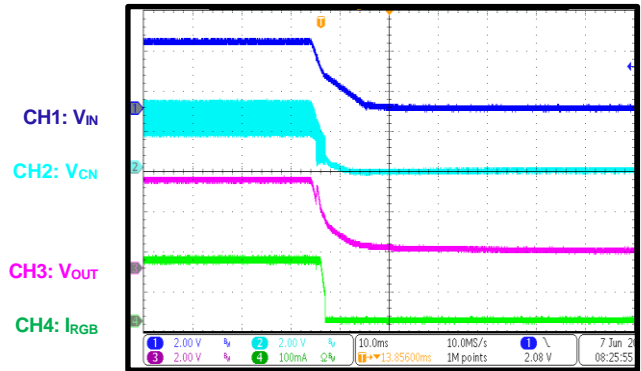

Start-Up through EN

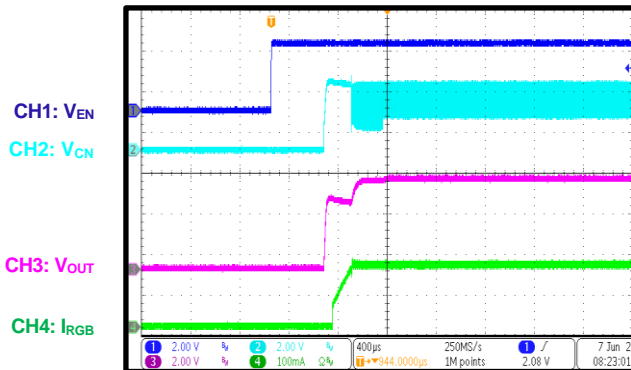

Shutdown through EN

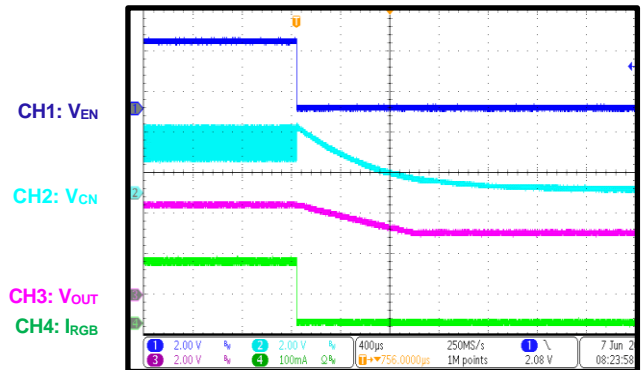

TYPICAL PERFORMANCE CHARACTERISTICS (continued)
 $V_{IN} = 3.3V$, RGB LED load, 50mA/channel, $f_{SW} = 1MHz$, $T_A = 25^{\circ}C$, unless otherwise noted.

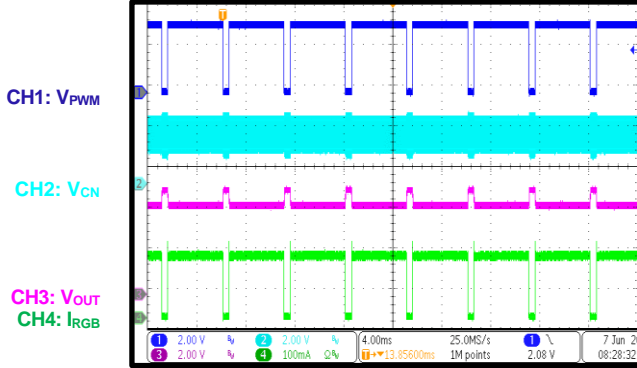
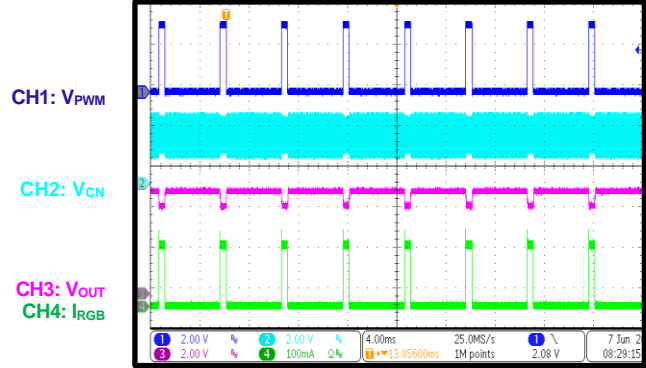
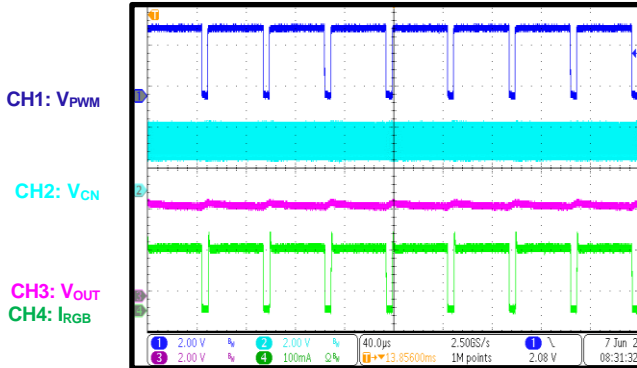
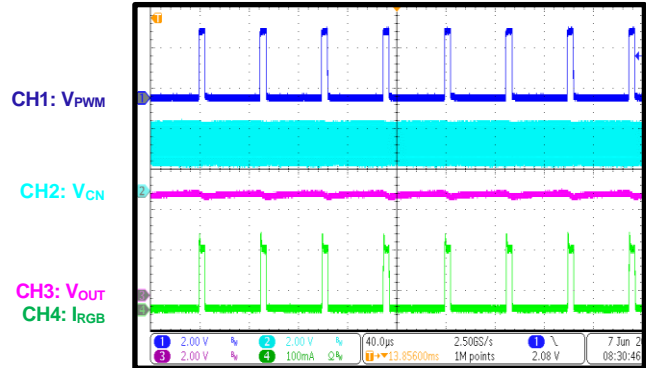
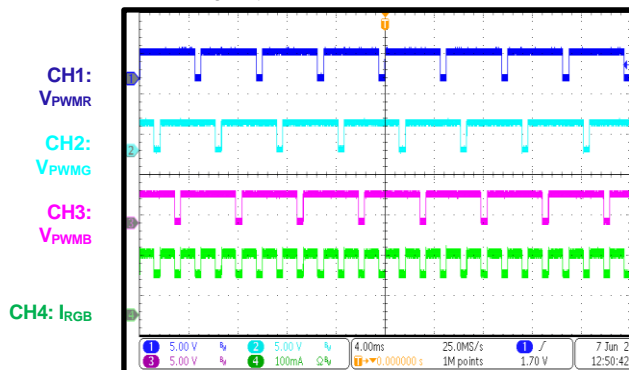
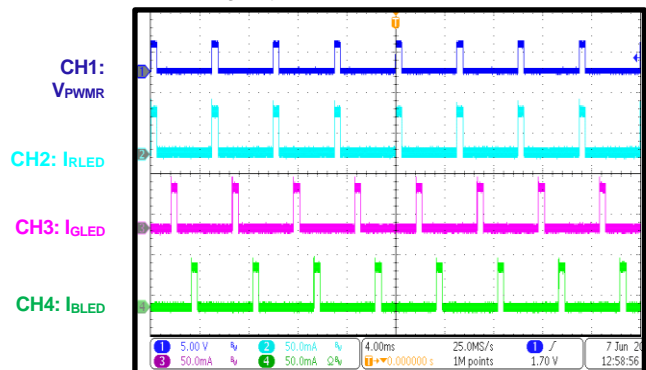
PWM Dimming with Synchronous PWM Signal
 $f_{PWM} = 200Hz$, $D_{PWMR} = D_{PWGM} = D_{PWMB} = 90\%$

PWM Dimming with Synchronous PWM Signal
 $f_{PWM} = 200Hz$, $D_{PWMR} = D_{PWGM} = D_{PWMB} = 10\%$

PWM Dimming with Synchronous PWM Signal
 $f_{PWM} = 20kHz$, $D_{PWMR} = D_{PWGM} = D_{PWMB} = 90\%$

PWM Dimming with Synchronous PWM Signal
 $f_{PWM} = 20kHz$, $D_{PWMR} = D_{PWGM} = D_{PWMB} = 10\%$

PWM Dimming with Asynchronous PWM Signal
 $f_{PWM} = 200Hz$, $D_{PWMR} = D_{PWGM} = D_{PWMB} = 90\%$, phase lags by 120° in sequence

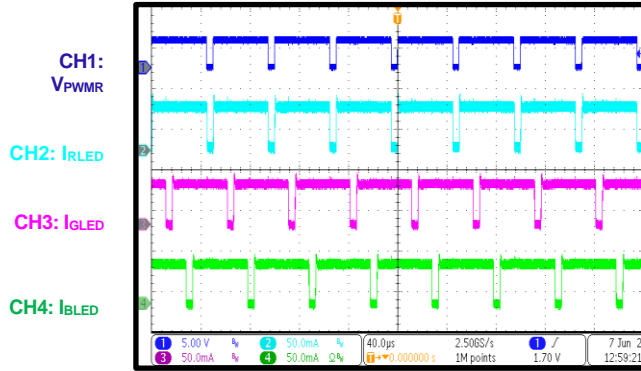
PWM Dimming with Asynchronous PWM Signal
 $f_{PWM} = 200Hz$, $D_{PWMR} = D_{PWGM} = D_{PWMB} = 10\%$, phase lags by 120° in sequence

TYPICAL PERFORMANCE CHARACTERISTICS (continued)

$V_{IN} = 3.3V$, RGB LED load, 50mA/channel, $f_{SW} = 1MHz$, $T_A = 25^{\circ}C$, unless otherwise noted.

PWM Dimming with Asynchronous PWM Signal

$f_{PWM} = 20kHz$, $D_{PWMR} = D_{PWGM} = D_{PWMB} = 90\%$, phase lags by 120° in sequence



PWM Dimming with Asynchronous PWM Signal

$f_{PWM} = 20kHz$, $D_{PWMR} = D_{PWGM} = D_{PWMB} = 10\%$, phase lags by 120° in sequence

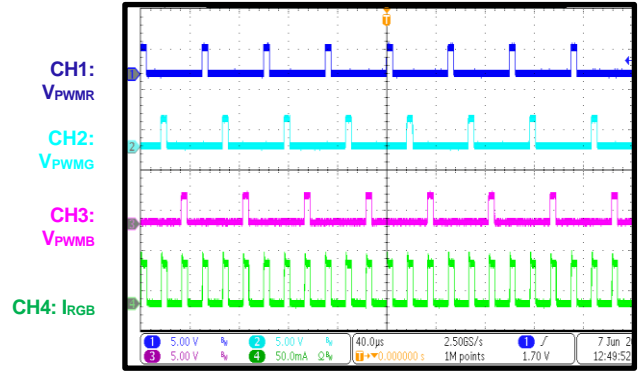

LED Open Protection

Open RLED load during normal operation

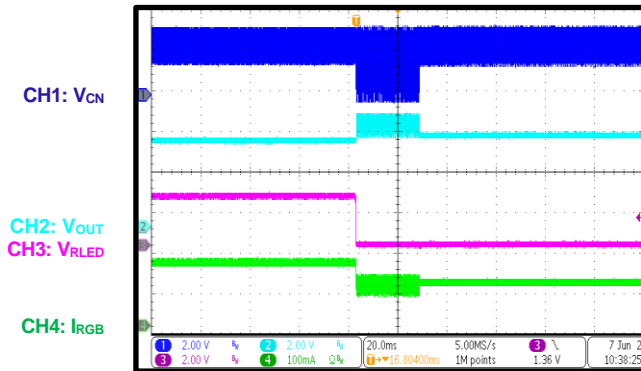

LED Short Protection

Short RLED load during normal operation

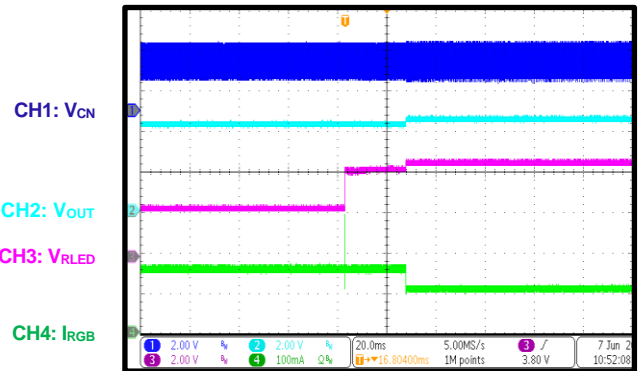

Over-Temperature Protection

$V_{IN} = 5.4V$

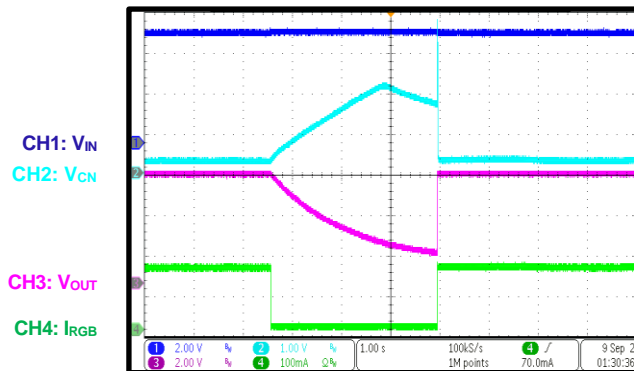

OPERATION

The MP3320N is an RGB LED driver that integrates a self-adaptive charge pump block, and is ideal for LED indicators and smart device lighting. It offers up to 3 channels of regulated current sources with separated pulse-width modulation (PWM) dimming.

System Start-Up

When the input voltage (V_{IN}) exceeds the under-voltage lockout (UVLO) threshold and the EN pin is pulled high, the MP3320N is enabled and system starts up.

Self-Adaptive Charge Pump Converter

The MP3320N integrates a self-adaptive charge pump converter, which automatically chooses the active lowest headroom voltage (V_{LEDx_MIN}) of all used channels. The initial conversion rate is 1x when the device starts up.

If V_{LEDx_MIN} is below 0.4V, the conversion rate rises a step. For example, a 1x current rate rises to 1.5x, and a 1.5x current rate rises to 2x. If V_{LEDx_MIN} exceeds $(0.5 \times V_{IN} + 0.5V)$ and lasts for 20ms, the conversion rate reduces a step. For example, a 1.5x current rate drops to 1x, and a 2x current rate drops to 1.5x.

If the output voltage (V_{OUT}) reaches the over-voltage protection (OVP) threshold five consecutive times and each time interval is less than 1ms, then the conversion rate decreases by a step.

Configurable LED Current Amplitude

The MP3320N supports a configurable 5mA to 100mA (8-bit) LED current (I_{LED}) amplitude for each channel. The default is 50mA/Ch. The default can be customized I_{LED} amplitude via the one-time programmable memory.

Pulse-Width Modulation (PWM) Dimming

The MP3320N supports separated PWM dimming for each channel via the input PWM dimming signal on the PWMR, PWMG, and PWMB pins. Each channel's I_{LED} is directly chopped by the corresponding PWM signal.

Protection Features

The MP3320N integrates LED open protection, LED short protection, over-voltage protection (OVP), and over-temperature protection (OTP).

LED Open Protection

LED open protection is achieved by detecting the LEDx pin voltage (V_{LEDx}). When one string is open, the corresponding V_{LEDx} drops. If V_{LEDx} falls below the LED open protection threshold (V_{LED_UVP}) and lasts for 24ms, then LED open protection is triggered and the open fault channel is marked off. Once a channel is marked off, it is disconnected from the V_{OUT} loop until V_{IN} or EN restarts.

LED Short Protection

The MP3320N monitors V_{LEDx} to determine whether an LED short fault has occurred. If one or more strings are shorted, the respective LED pins tolerate high voltage stress. If a certain V_{LEDx} exceeds the LED short protection threshold (V_{SLP}) and lasts for 24ms, then LED short protection is triggered and the fault channel is marked off. Once a channel is marked off, it is disconnected from the V_{OUT} loop until V_{IN} or EN restarts.

Over-Voltage Protection (OVP)

OVP is achieved by detecting V_{OUT} . If V_{OUT} reaches the OVP high threshold (V_{OVP}), OVP is triggered and the IC stops switching. The IC tries to recover once V_{OUT} drops to the OVP low threshold (V_{OVP} minus the hysteresis). The hysteresis is typically 500mV.

Over-Temperature Protection (OTP)

To prevent the IC from operating at exceedingly high temperatures, OTP is implemented by detecting the silicon die temperature. If the die temperature exceeds the upper threshold (T_{ST}), the IC shuts down. Once the die temperature drops below the lower threshold (T_{ST} minus the hysteresis), the part restarts and resumes normal operation. Typically, the hysteresis is 25°C.

APPLICATION INFORMATION

Selecting the Input Capacitor (C_{IN})

The input capacitor (C_{IN}) reduces the surge current drawn from the input supply and the switching noise from the device. The C_{IN} impedance at the switching frequency (f_{SW}) should be less than the input source impedance to prevent the high-frequency switching current from passing through to the input. Ceramic capacitors with X5R or X7R dielectrics are recommended for their low ESR and small temperature coefficients. For most applications, a 4.7 μ F ceramic capacitor is sufficient.

Selecting the Output Capacitor (C_{OUT})

The output capacitor (C_{OUT}) keeps the output voltage ripple (ΔV_{OUT}) small and ensures feedback loop stability. The C_{OUT} impedance must be low at f_{SW} . Ceramic capacitors with X7R dielectrics are recommended for their low ESR characteristics. For most applications, a 4.7 μ F ceramic capacitor is sufficient.

PCB Layout Guidelines

Efficient PCB layout is critical for stable operation. For the best results, refer to Figure 2 and follow the guidelines below:

1. Place the bypass capacitor for VIN and the flying capacitors as close to the MP3320N as possible to minimize the current loops.

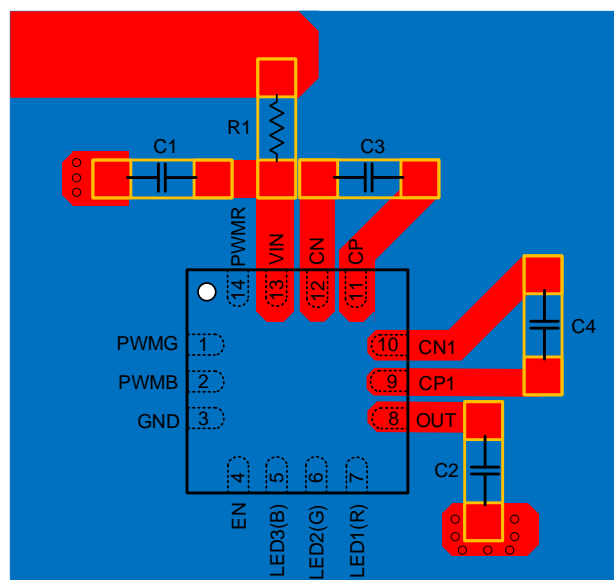
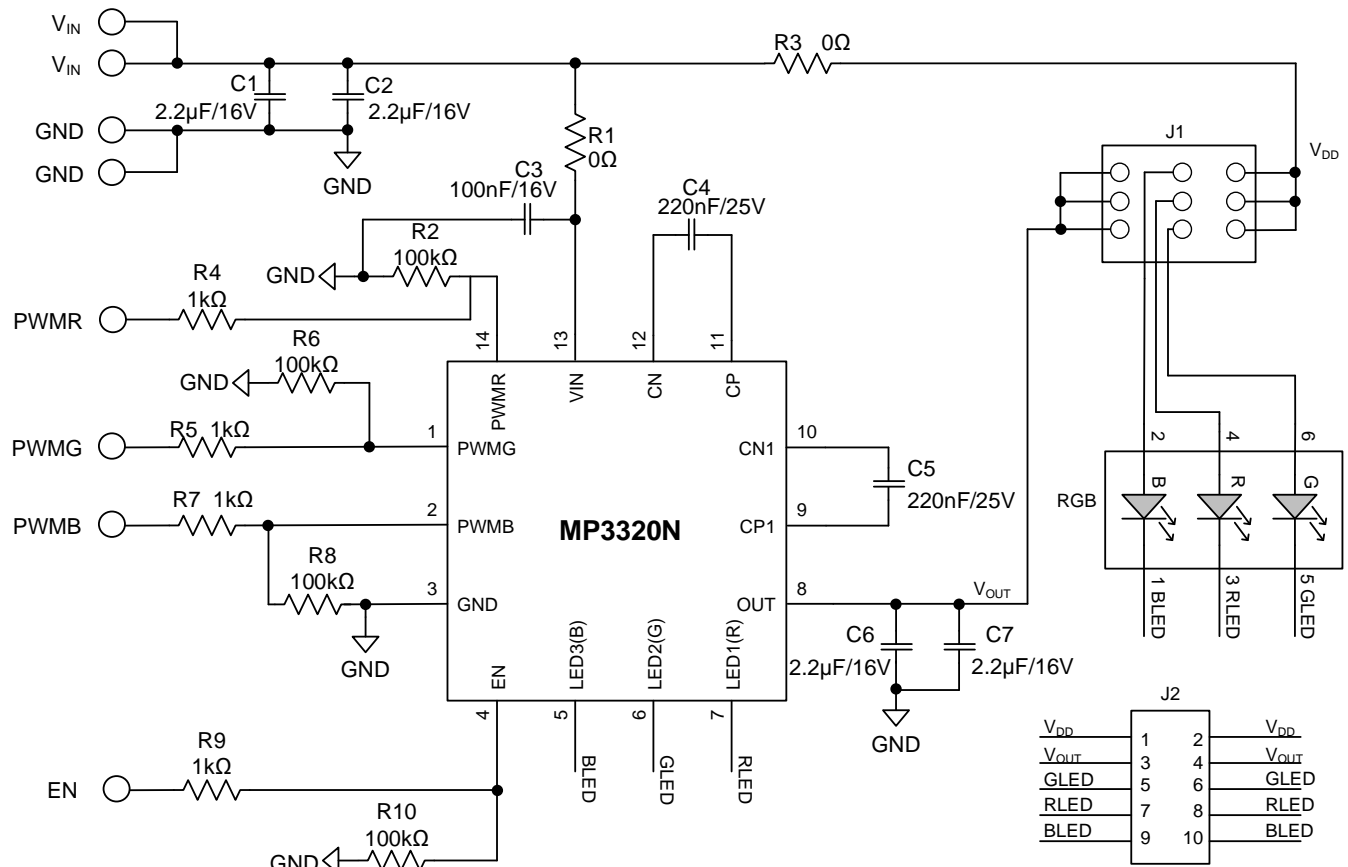
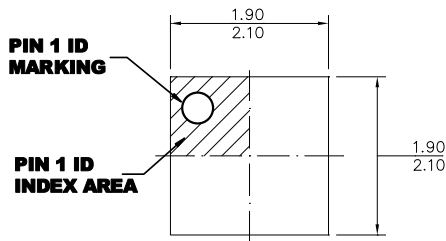

Figure 2: Recommended PCB Layout

TYPICAL APPLICATION CIRCUIT

Figure 3: Typical Application Circuit

PACKAGE INFORMATION

QFN-14 (2mmx2mm)

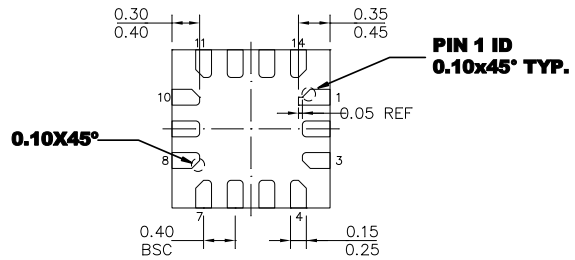

TOP VIEW



BOTTOM VIEW

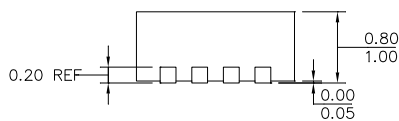

SIDE VIEW

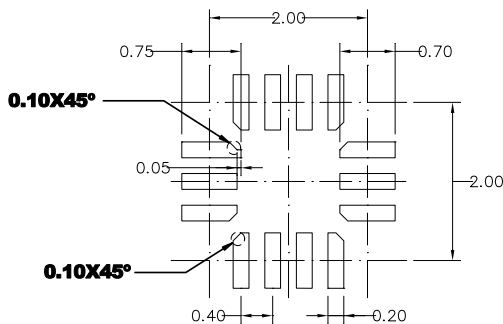

RECOMMENDED LAND PATTERN

NOTE:

- 1) ALL DIMENSIONS ARE IN MILLIMETERS.
- 2) LEAD COPLANARITY SHALL BE 0.08 MILLIMETERS MAX.
- 3) JEDEC REFERENCE IS MO-220.
- 4) DRAWING IS NOT TO SCALE.

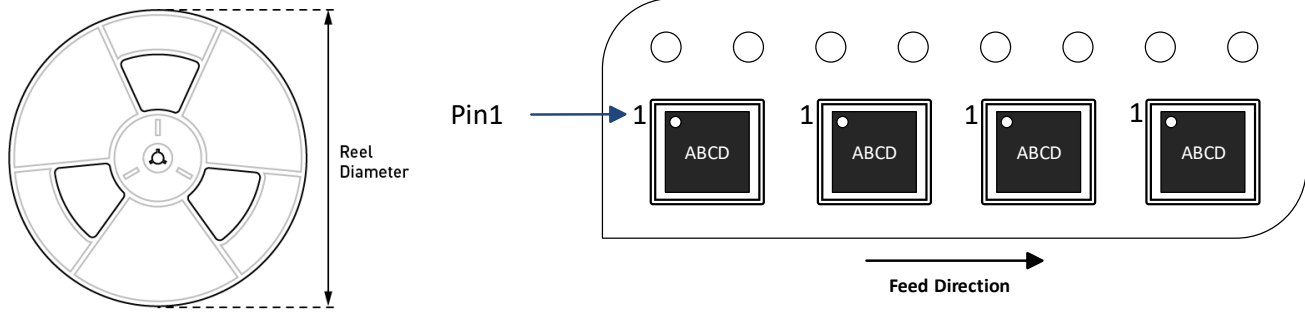
CARRIER INFORMATION

Part Number	Package Description	Quantity/ Reel	Quantity/ Tube	Quantity/ Tray	Reel Diameter	Carrier Tape Width	Carrier Tape Pitch
MP3320NGG-Z	QFN-14 (2mmx2mm)	5000	N/A	N/A	13in	12mm	8mm

REVISION HISTORY

Revision #	Revision Date	Description	Pages Updated
1.0	10/30/2023	Initial Release	-

Notice: The information in this document is subject to change without notice. Please contact MPS for current specifications. Users should warrant and guarantee that third-party Intellectual Property rights are not infringed upon when integrating MPS products into any application. MPS will not assume any legal responsibility for any said applications.