

CONNECTOR LINK WIDTH	# POS	"N"	DIM "A"	DIM "B"	DIM "C"
X1	36	6	7.65	25.00	28.60
X4	64	20	21.65	39.00	42.60
X8	98	37	38.65	56.00	59.60
X16	164	70	71.65	89.00	92.60

spec ref	dr	Soman-adm, Shi	2023/09/27	projection	MM	size	A3	scale	3:1
tolerance std	eng	Cong-Lin Zhao	2026/01/06			ecn no	rel level	Released	rev
ASME Y14.5	chr	-	-						
TOLERANCES UNLESS OTHERWISE SPECIFIED				product family	PCI Express	rel level		Released	rev
surface	linear	0.X	±.3	Amphenol FCI		PCI Express 6.0		dwg no	10173133
		0.XX	±.20	Assembly, Straddle Mount Type					A
		0.XXX	±.100						
ASME Y14.5	angular	0°	±2°	cat. no.	-	Product - Customer Drw	sheet 1 of 4		

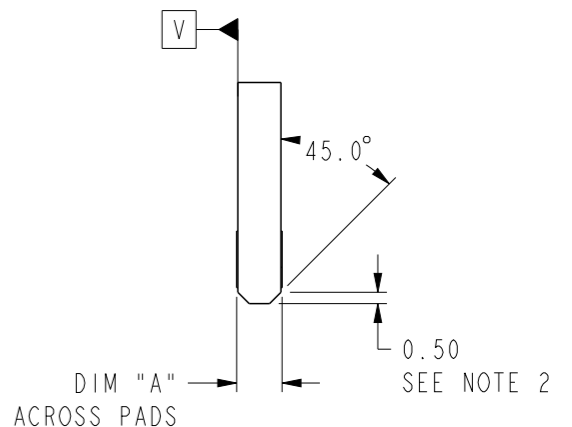
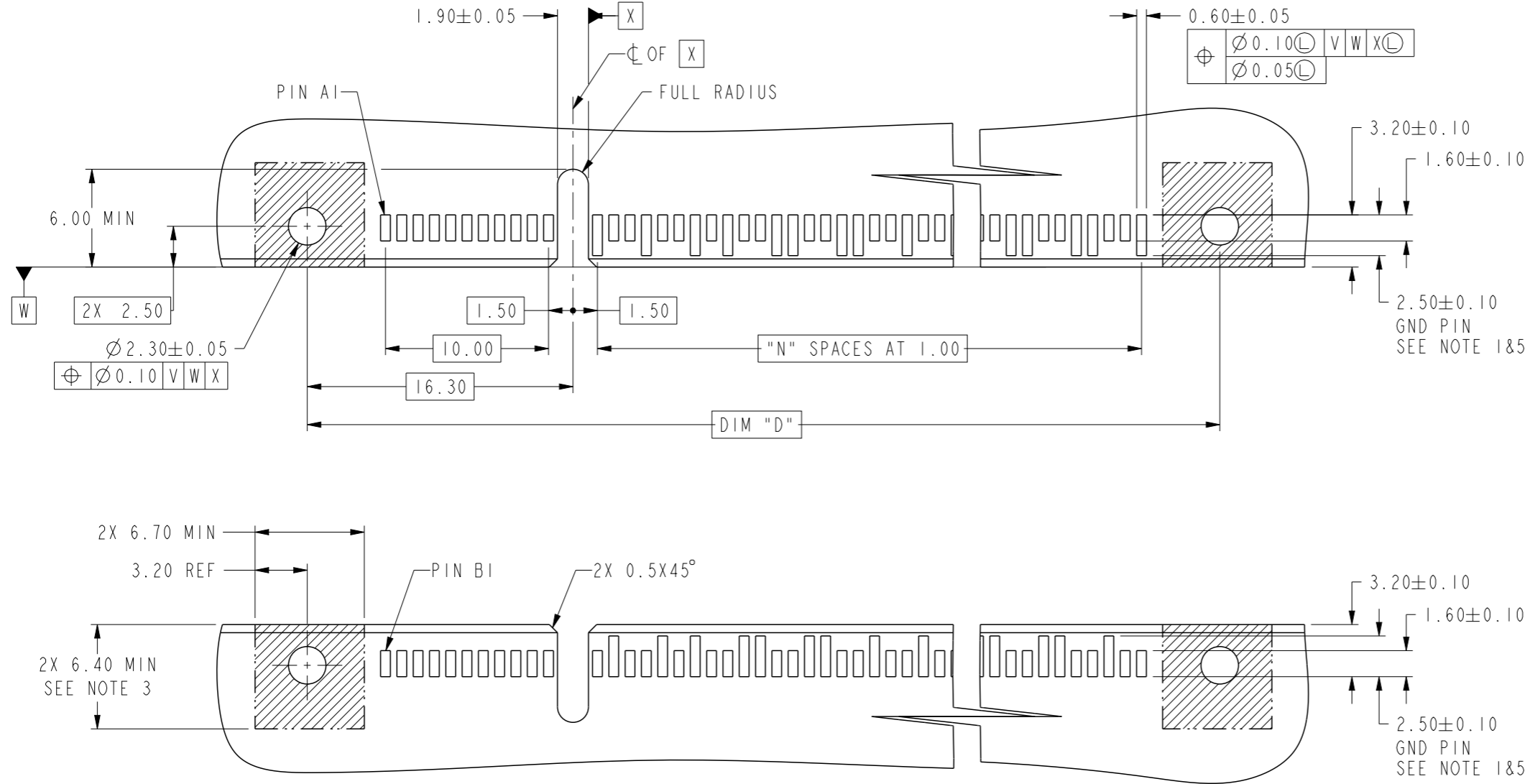

THE THICKNESS	DIM "A"
1.57mm	1.57±0.13
2.00mm	2.00±0.13
2.36mm	2.36±0.13
2.54mm	2.54±0.13

**RECOMMENDED PCB LAYOUT
(DETAILS : SEE PCIE STRADDLE MOUNT ROUTING GUIDELINE SPEC)**

NOTES:

- LOCATION OF PIN "C":
 36 POS: A12,A15,A18,
 B13,B16,B18.
 64 POS: A12,A15,A18,A20,A23,A24,A27,A28,A31,
 B13,B16,B18,B21,B22,B25,B26,B29,B32.
 98 POS: A12,A15,A18,A20,A23,A24,A27,A28,A31,A34,A37,A38,A41,A42,A45,A46,A49,
 B13,B16,B18,B21,B22,B25,B26,B29,B32,B35,B36,B39,B40,B43,B44,B47,B49.
 164 POS: A12,A15,A18,A20,A23,A24,A27,A28,A31,A34,A37,A38,A41,A42,A45,A46,A49,A51,A54,A55,A58,A59,A62,A63,A66,A67,A70,A71,A74,A75,A78,A79,A82,
 B13,B16,B18,B21,B22,B25,B26,B29,B32,B35,B36,B39,B40,B43,B44,B47,B49,B52,B53,B56,B57,B60,B61,B64,B65,B68,B69,B72,B73,B76,B77,B80.
- CHAMFER EDGES MUST BE FREE FROM CUTTING BURRS.
- CONNECTOR KEEP OUT ZONE:
 PCB COMPONENTS ARE NOT ALLOWED ON BOTH SIDES.
- TOLERANCE UNLESS OTHERWISE SPECIFIED:±0.13MM
- SEE PCIE STRADDLE MOUNT ROUTING GUIDELINE SPEC

CONNECTOR LINK WIDTH	# POS	"N"	DIM "D"
X1	36	6	28.60
X4	64	20	42.60
X8	98	37	59.60
X16	164	70	92.60

spec ref	dr	Soman-adm, Shi	2023/09/27	projection	MM	size	A3	scale	3:1
tolerance std	eng	Cong-Lin Zhao	2026/01/06			ecn no	rel level	Released	rev
ASME Y14.5	chr	-	2026/01/06						
	appr	Breeze Lv	2026/01/06	product family	PCI Express	dwg no	10173133		A
surface	linear	0.X	±.3	Amphenol FCI		PCI Express 6.0		cat. no.	-
		0.XX	±.20	Assembly, Straddle Mount Type		Product - Customer Drw		sheet 2 of 4	
	angular	0°	±2°			STATUS:Released		Printed: Jan 06, 2026	

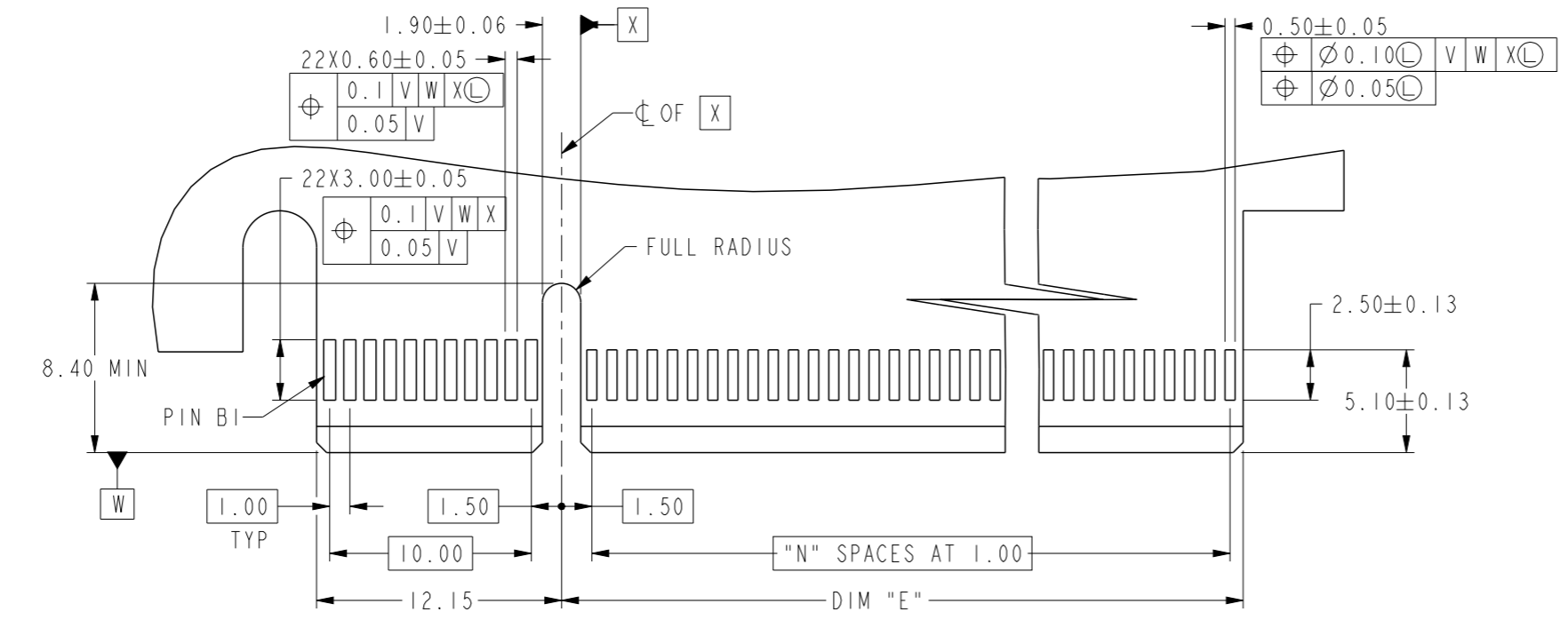

ADD-IN CARD EDGE-FINGER DIMENSIONS
PRIMARY (COMPONENT) SIDE
(DETAILS : SEE PCIE STRADDLE MOUNT ROUTING GUIDELINE SPEC)

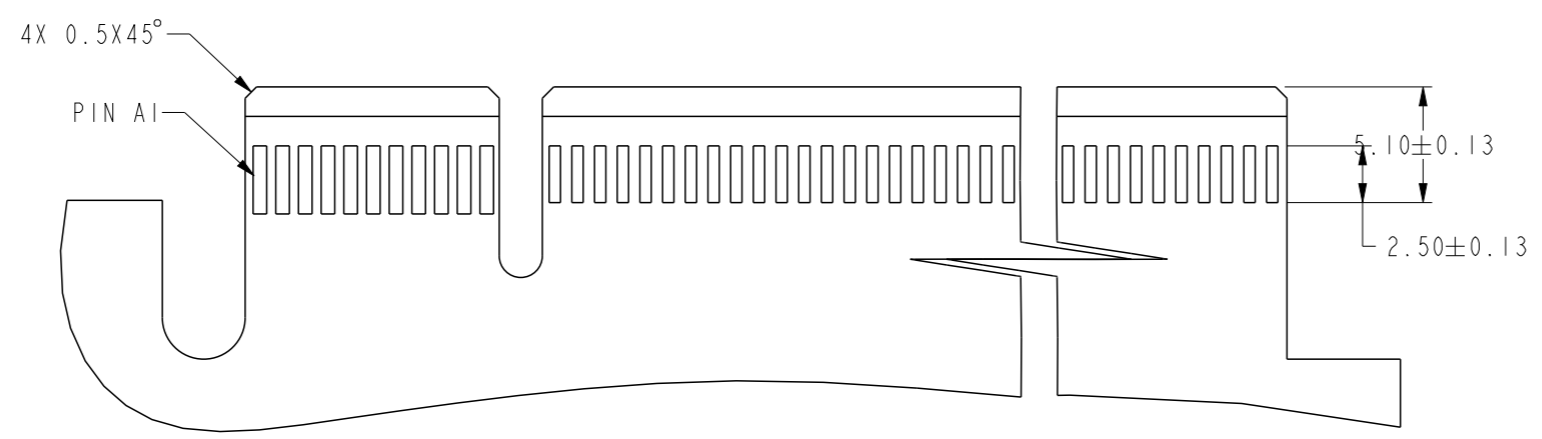
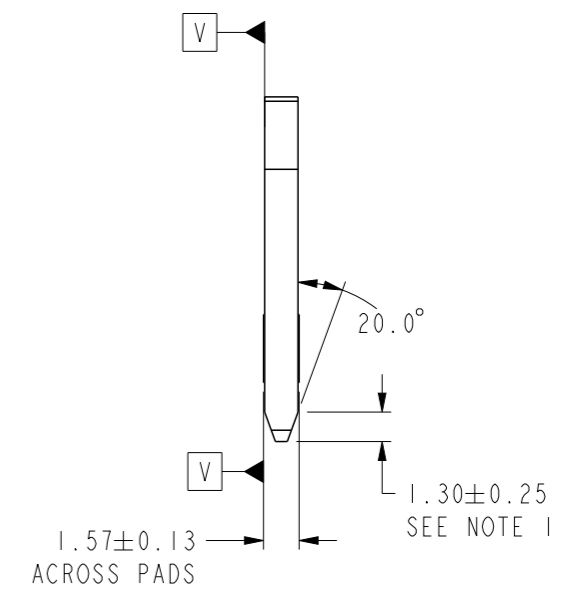

ADD-IN CARD EDGE-FINGER DIMENSIONS
SENCONDARY (SOLDER) SIDE
(DETAILS : SEE PCIE STRADDLE MOUNT ROUTING GUIDELINE SPEC)

NOTES:

1. CHAMFER EDGES MUST BE FREE FROM CUTTING BURRS.
2. PCIe CEM 6.0 HAS NOT BEEN FINALIZED AND PUBLISHED. ADD-IN CARD DEFINITION IN THE DRAWING IS JUST FOR REFERENCE, IT IS SUBJECTED TO CHANGE WHEN CEM 6.0 UPDATE.
3. TOLERANCE UNLESS OTHERWISE SPECIFIED:±0.13MM
4. SEE PCIE STRADDLE MOUNT ROUTING GUIDELINE SPEC

CONNECTOR LINK WIDTH	# POS	"N"	DIM "E"
X1	36	6	8.15
X4	64	20	22.15
X8	98	37	39.15
X16	164	70	72.15

spec ref	dr	Soman-adm, Shi	2023/09/27	projection	MM	size	A3	scale	3:1
tolerance std	eng	Cong-Lin Zhao	2026/01/06			ecn no	rel level	Released	rev
ASME Y14.5	chr	-	-						
TOLERANCES UNLESS OTHERWISE SPECIFIED	appr	Breeze Lv	2026/01/06	product family	PCI Express	rel level	Released		
surface	linear	0.X	±.3	Amphenol FCI		dwg no	10173133	cat. no.	-
		0.XX	±.20	PCI Express 6.0				Product - Customer Drw	sheet 3 of 4
		0.XXX	±.100	Assembly, Straddle Mount Type					
ASME Y14.5	angular	0°	±2°						

NOTES:

1. MATERIAL:
HOUSING: HIGH TEMP THERMOPLASTIC, BLACK, UL94-V0.
CAP: HIGH TEMP THERMOPLASTIC, BLACK, UL94-V0.
CONTACT: COPPER ALLOY.
2. PLATING:
MATING AREA: GOLD OVER NICKEL (SEE PART NUMBER CODE).
SOLDER AREA: TIN OVER NICKEL (LEAD FREE).
3. PRODUCT SPECIFICATION: GS-12-1193.
4. PACKAGE SPECIFICATION: GS-14-XXXX.
5. PACKAGING MEETS GS-14-920 LEAD FREE LABELING SPECIFICATION.
6. PRODUCT MEETS EUROPEAN UNION DIRECTIVES AND OTHER COUNTRY REGULATIONS AS DESCRIBED IN GS-47-0004.
- ⑦ PRODUCT MARKING (PART NUMBER, DATE CODE OR PROTOTYPE) TO BE LASER MARKED ON THIS SURFACE.
- ⑧ TWO M2 SCREWS WITH A MINIMUM LENGTH OF 8.0MM AND TWO HEX NUTS ARE RECOMMENDED TO BE USED TO ATTACH THE CONNECTOR TO THE PCB. SCREWS AND NUTS ARE NOT PROVIDED WITH CONNECTOR.
- ⑨ ALL DIFFERENTIAL PAIR GROUNDS ON SAME SIDE ARE CONNECTED BY GROUND BUSSING WITHIN CONNECTOR. FOR THE LOCATION OF GROUNDS, PLEASE REFER TO THE PINOUT OF PCI EXPRESS CARD ELECTROMECHANICAL SPECIFICATION.
- ⑩ THE CAP SHOULD BE ASSEMBLED DURING REFLOW PROCESS.
11. THE PRODUCT WILL WITHSTAND EXPOSURE TO 260°C PEAK TEMPERATURE FOR 10 SECONDS IN A CONVECTION, INFRA-RED OR VAPOR PHASE REFLOW OVEN.

PART NUMBER CODE:

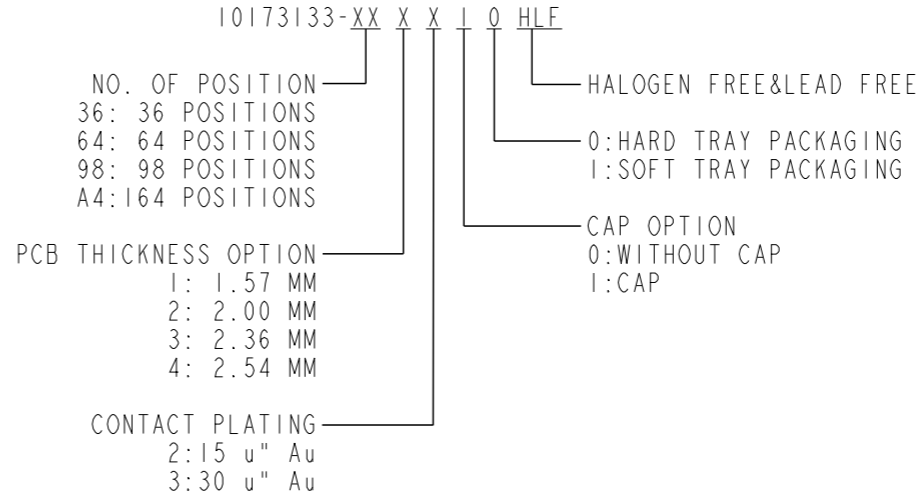

DATE CODE:

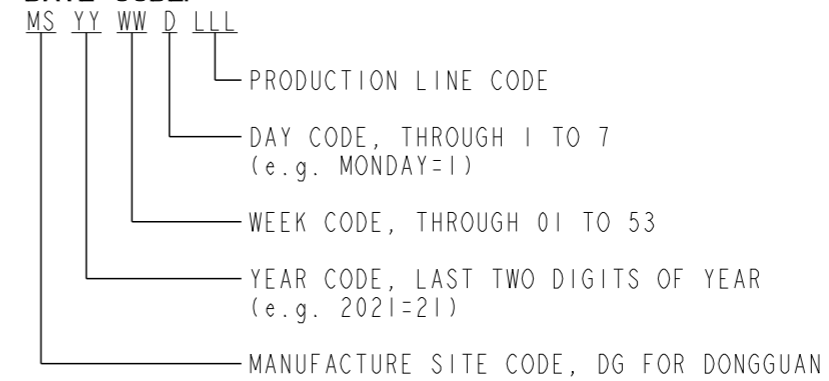

spec ref		dr	Soman-adm, Shi	2023/09/27	projection	MM	size	A3	scale	3:1
tolerance std		eng	Cong-Lin Zhao	2026/01/06		← →	ecn no		rel level	
ASME Y14.5		chr	-	-			product family		PCI Express	
surface		appr	Breeze Lv	2026/01/06	PCI Express 6.0		dwg no		10173133	
ASME Y14.5		TOLERANCES UNLESS OTHERWISE SPECIFIED		Amphenol FCI		Assembly, Straddle Mount Type		rev		A
linear	0.X ±.3	0.XX ±.20	0.XXX ±.100	cat. no.		-		Product - Customer Drw		sheet 4 of 4
angular	0° ±2°									