

Part Number: 4277353509

77 SLEEVE

Explanation of Part Numbers:

- Digits 1 & 2 = Product Class
- Digits 3 & 4 = Material Grade

Pressed Fair-Rite rods are used extensively in high-energy storage designs.

These rods can also be used for inductive components that require temperature stability or have to accommodate large dc bias requirements.

Figure 2 rods have a 0.6 mm (0.024) maximum chamfer on the end faces.

For frequency tuned rod designs see section Antenna/RFID Rods.

For any rod requirement not listed here, feel free to contact our customer service group for availability and pricing.

[3D Model](#)

The A dimension can be centerless ground to tighter tolerances.

Weight: 43 (g)

Dim	mm	mm tol	nominal inch	inch misc.
A	21	±0.50	0.827	—
B	6.9	±0.40	0.272	—
C	29	±0.60	1.142	—

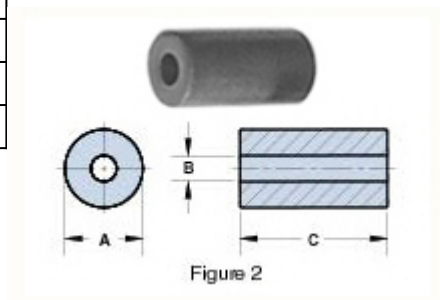

Figure 1 shows the rod permeability as a function of the length to diameter ratio for the six materials available in rods.

Figures 3, 4 and 5 illustrate typical temperature behavior of wound rods. Would rods in 33

and 77 material yield the best temperature stable inductors, see Figure 4. Both show a typical inductance change of <1% over the -40° to 120°C temperature range. The parts have a L/D ratio of 8.1. Lower ratios will change less. This is shown in detail in Figure 5 for the same 52 material but with the L/D ratio as the parameter. A lower ratio means a lower rod permeability but with improved temperature stability.



Wound Rod Inductance Calculations

To calculate the inductances of a wound rod the following formula can be used,



The inductance modifier is found in Figure 2. The ratio winding length divided by the rod length will give the inductance modifier. If the rod is totally wound the K=1. Shorter but centered winding will yield higher K values.

Using the rod 3061990871 as an example.

For this rod the length over diameter ratio is 8.33 and for 61 material Figure 1 gives a μ rod of 29. The rod has an AE= 0.0707 cm² and ϕ =2.5 cm.

A winding of 80 turns of 30 AWG wire will yield a fully wound rod, therefore K=1.

Using the formula the calculated inductance is 65.96 μ H.

The measured values for both winding were 66.95 and 39.50 μ H respectively.



Fair-Rite Products Corp. • One Commercial Row, Wallkill, New York 12589-0288
888-324-7748 • 845-895-2055 • Fax: 845-895-2629 • ferrites@fair-rite.com • www.fair-rite.com