

Customer Information Sheet

DRAWING No.: S70-332002045R

IF IN DOUBT - ASK

©

NOT TO SCALE

THIRD ANGLE PROJECTION

ALL DIMENSIONS IN mm

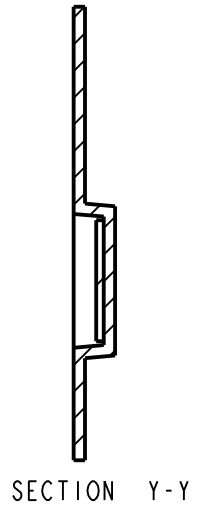
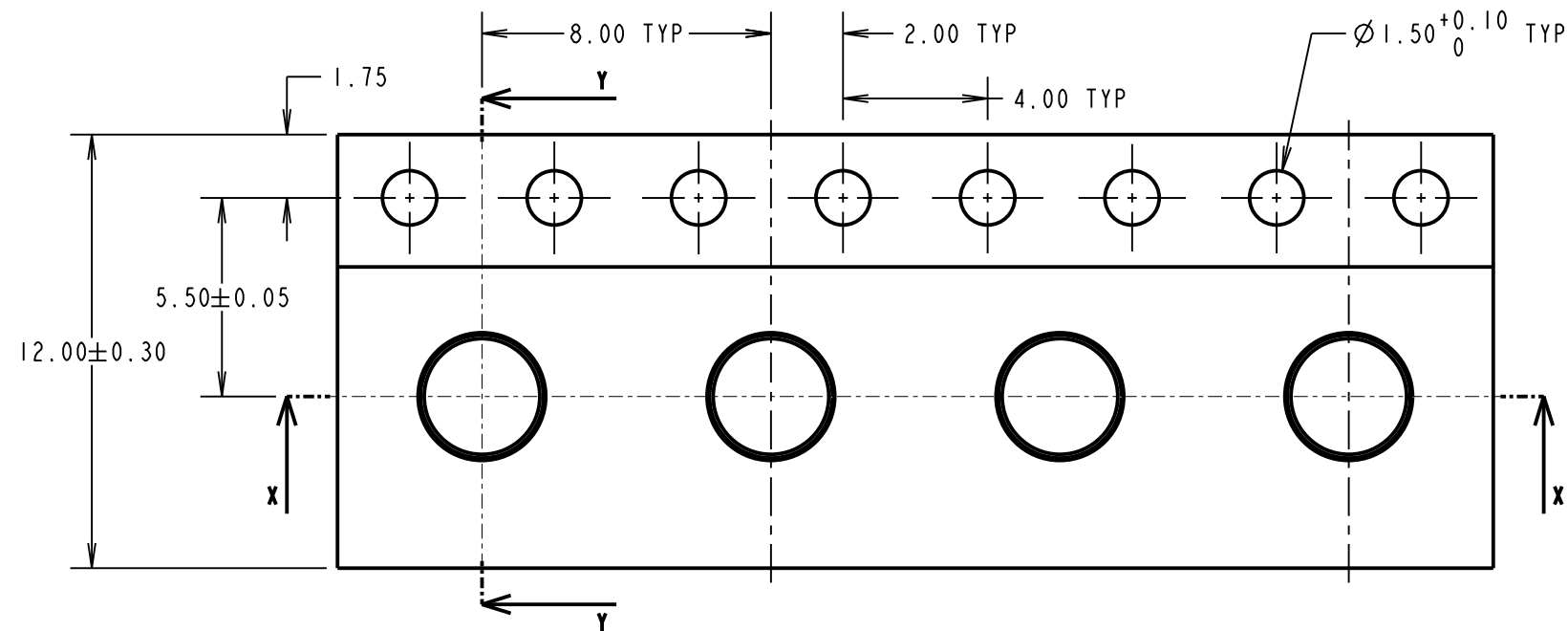
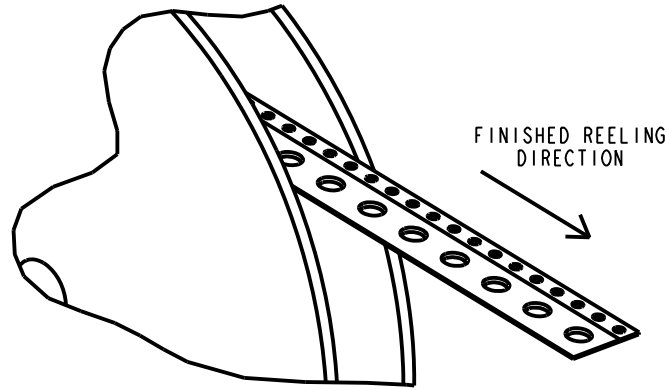

COMPONENT DETAILS

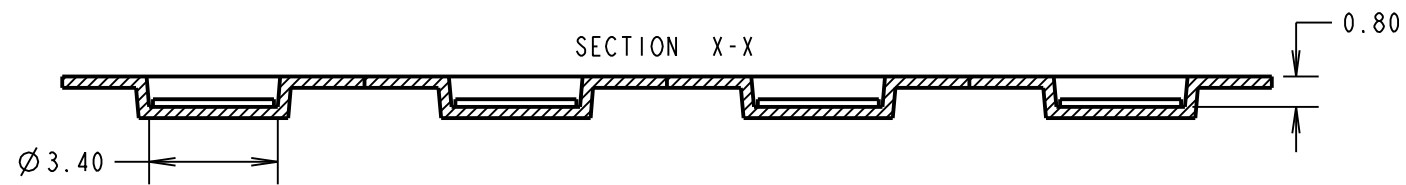
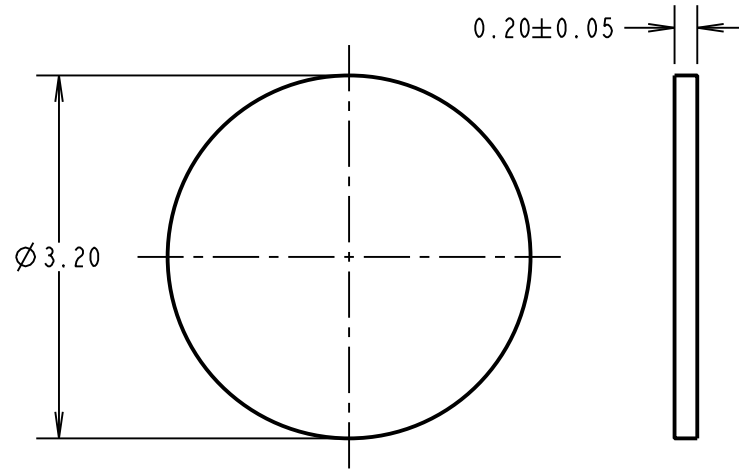

RECOMMENDED PCB LAYOUT

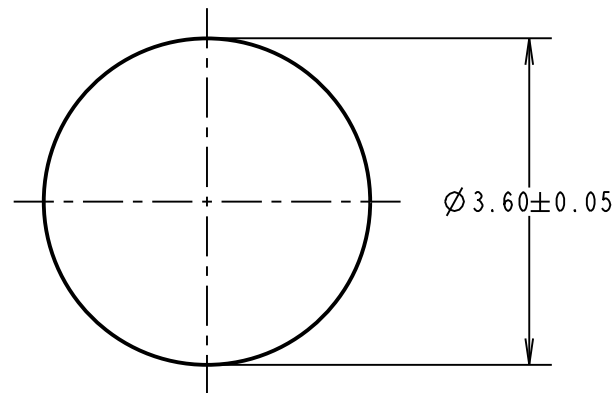

REEL DETAILS

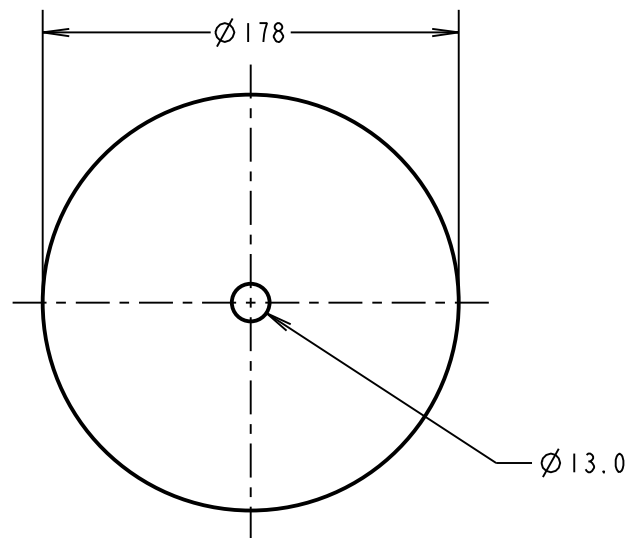

SPECIFICATIONS:

FINISH:

0.025µm - 0.075µm GOLD OVER 1.5µm - 3.0µm NICKEL

ELECTRICAL:

CURRENT RATING = 6.0A

CONTACT RESISTANCE = 0.15mΩ MAX

ENVIRONMENTAL:

OPERATING TEMPERATURE = -40°C TO +180°C

PACKING:

QUANTITY: 2000 PER REEL

NOTES:

1. QUANTITY OF COMPONENTS PER REEL = 2000.

2. PRODUCT IS TAPE AND REELED IN GENERAL ACCORDANCE WITH EIA-481.

RA	5	20.02.20	22028
NAME	ISS.	DATE	C/NOTE
APPROVED:		R.ALEXANDER	
CHECKED:		R.PORTLOCK	
DRAWN:		M.PERREN	
CUSTOMER REF.:			
ASSEMBLY DRG:			

HARWIN

www.harwin.com
technical@harwin.com

THIS DRAWING AND ANY INFORMATION OR DESCRIPTIVE MATTER SET OUT HEREON ARE CONFIDENTIAL AND COPYRIGHT PROPERTY OF THE HARWIN GROUP AND MUST NOT BE DISCLOSED, LOANED, COPIED OR USED FOR MANUFACTURING, TENDERING OR FOR ANY OTHER PURPOSE WITHOUT THEIR WRITTEN PERMISSION.

TOLERANCES

X. = ±1mm
X.X = ±0.50mm
X.XX = ±0.20mm
X.XXX = ±0.01mm
ANGLES = ±5°
UNLESS STATED

MATERIAL:

BERYLLIUM COPPER

FINISH: SEE ABOVE

S/AREA: 18.1 mm²

TITLE:

SMT CIRCULAR CONTACT PAD

DRAWING NUMBER:

S70-332002045R

SHT
2 OF 2