

Data Sheet | Item Number: 2706-155

PCB terminal block; lever; 6 mm²; Pin spacing 7.5 mm; 5-pole; CAGE CLAMP®; commoning option; gray

<https://www.wago.com/2706-155>



Color: ■ gray

Similar to illustration

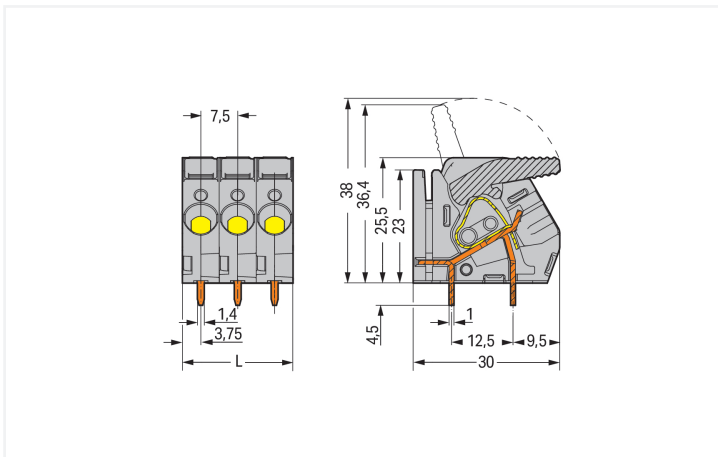
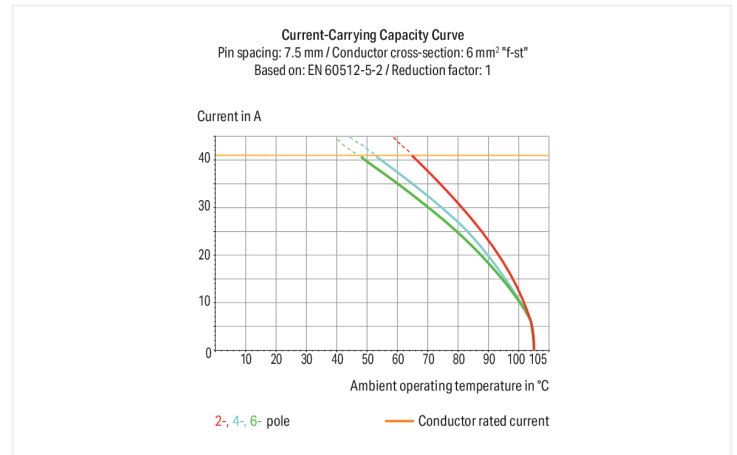

Dimensions in mm

L = pole no. x pin spacing

PCB terminal block, 2706 Series, with 7.5 mm pin spacing

Connect conductors quickly and safely with this PCB terminal block (item number 2706-155). It is a universal connector that can be used practically anywhere, for example, as a pluggable PCB connector, panel feedthrough header, connector for rail-mount terminal blocks, or a floating connector for different mounting methods. Conductors should only be connected to this PCB terminal block if their strip length is between 11 and 12 mm. Featuring one conductor terminal along with CAGE CLAMP®, this connector outperforms the competition. Our reliable and maintenance-free CAGE CLAMP® connection makes it easy to connect all types of conductors without having to prepare the conductor. For example, you don't need to crimp ferrules. Dimensions: (37.5 x 30 x 30) mm (width x height x depth). Depending on the conductor type, this PCB terminal block is ideal for conductor cross sections ranging from 0.5 mm² to 6 mm².

The contact surface is coated with tin. A lever is used to operate this PCB terminal block. The PCB terminal block is designed for THT soldering. Insert the conductor at a 30° angle..

Notes

Safety Information

Using adjacent jumpers, the rated voltage is reduced to 400 V with 7.5 mm pin spacing in Category III/3.

Variants:

Other pole numbers
Other colors
Mixed-color PCB connector strips
Direct marking
Other versions (or variants) can be requested from WAGO Sales or configured at <https://configurator.wago.com/>.

Electrical data

Ratings per	IEC/EN 60664-1			Approvals per	UL 1059		
Overvoltage category	III	III	II	Use group	B	C	D
Pollution degree	3	2	2	Rated voltage	300 V	150 V	300 V
Nominal voltage	500 V	630 V	1000 V	Rated current	30 A	30 A	30 A
Rated impulse withstand voltage	6 kV	6 kV	6 kV				
Rated current	41 A	41 A	41 A				

Connection Data

Clamping units	5	Connection 1	
Total number of potentials	5	Connection technology	CAGE CLAMP®
Number of connection types	1	Actuation type	Lever
Number of levels	1	Solid conductor	0.5 ... 6 mm ² / 20 ... 10 AWG
Number of jumper slots	1	Fine-stranded conductor	0.5 ... 6 mm ² / 20 ... 10 AWG
		Fine-stranded conductor; with insulated ferrule	0.5 ... 6 mm ²
		Fine-stranded conductor; with uninsulated ferrule	0.5 ... 6 mm ²
		Strip length	11 ... 12 mm / 0.43 ... 0.47 inches
		Conductor connection direction to PCB	30 °
		Pole number	5

Physical data

Pin spacing	7.5 mm / 0.295 inches
Width	37.5 mm / 1.476 inches
Height	30 mm / 1.181 inches
Height from the surface	25.5 mm / 1.004 inches
Depth	30 mm / 1.181 inches
Solder pin length	4.5 mm
Solder pin dimensions	1 x 1.4 mm
Drilled hole diameter	1.8 ^(±0.1) mm

PCB contact

PCB contact	THT
Solder pin arrangement	over the entire terminal strip (in-line)
Number of solder pins per potential	2

Material data

Note (material data)	Information on material specifications can be found here
Color	gray
Material group	I
Insulation material (main housing)	Polyamide (PA66)
Flammability class per UL94	V0
Clamping spring material	Chrome-nickel spring steel (CrNi)
Contact material	Electrolytic copper (E _{Cu})
Contact Plating	Tin
Fire load	0.464 MJ
Weight	28.7 g

Environmental requirements

Limit temperature range	-60 ... +105 °C
-------------------------	-----------------

Commercial data

Product Group	4 (Printed Circuit Connectors)
PU (SPU)	30 pcs
Packaging type	Box
Country of origin	PL
GTIN	4050821093145
Customs tariff number	85369010000

Product Classification

UNSPSC	39121409
eCl@ss 10.0	27-44-04-01
eCl@ss 9.0	27-44-04-01
ETIM 9.0	EC002643
ETIM 10.0	EC002643
ECCN	NO US CLASSIFICATION

Environmental Product Compliance

RoHS Compliance Status	Compliant, No Exemption
------------------------	-------------------------

Approvals / Certificates

General approvals



Approval	Standard	Certificate Name
CCA DEKRA Certification B.V.	EN 60947	2143801.01
CCA DEKRA Certification B.V.	EN 60947-7-4	NTR NL-7869
CCA DEKRA Certification B.V.	EN 60947-7-4	71-117469
CSA DEKRA Certification B.V.	C22.2 No. 158	2516072
UL UL International Germany GmbH	UL 1059	E45172

Declarations of conformity and manufacturer's declarations

Approval	Standard	Certificate Name
EU-Declaration of Conformity WAGO GmbH & Co. KG	-	-
UK-Declaration of Conformity WAGO GmbH & Co. KG	-	-

Downloads

Environmental Product Compliance

Compliance Search

Environmental Product Compliance 2706-155



Documentation

Additional Information

Technical Section

03.04.2019

pdf

2027.26 KB



CAD/CAE-Data

CAD data

2D/3D Models
2706-155



CAE data

ZUKEN Portal
2706-155



PCB Design

Symbol and Footprint
via SamacSys
2706-155



Symbol and Footprint
via Ultra Librarian
2706-155



1 Compatible Products

1.1 Optional Accessories

1.1.1 Ferrule

1.1.1.1 Ferrule



Item No.: 216-262

Ferrule; Sleeve for 0.75 mm² / 18 AWG; insulated; electro-tin plated; electrolytic copper; gastight crimped; acc. to DIN 46228, Part 4/09.90; gray

Item No.: 216-263

Ferrule; Sleeve for 1 mm² / AWG 18; insulated; electro-tin plated; electrolytic copper; gastight crimped; acc. to DIN 46228, Part 4/09.90; red

Item No.: 216-264

Ferrule; Sleeve for 1.5 mm² / AWG 16; insulated; electro-tin plated; electrolytic copper; gastight crimped; acc. to DIN 46228, Part 4/09.90; black

Item No.: 216-266

Ferrule; Sleeve for 2.5 mm² / AWG 14; insulated; electro-tin plated; electrolytic copper; gastight crimped; acc. to DIN 46228, Part 4/09.90; blue



Item No.: 216-267

Ferrule; Sleeve for 4 mm² / AWG 12; insulated; electro-tin plated; electrolytic copper; gastight crimped; acc. to DIN 46228, Part 4/09.90; gray

Item No.: 216-208

Ferrule; Sleeve for 6 mm² / AWG 10; insulated; electro-tin plated; electrolytic copper; gastight crimped; acc. to DIN 46228, Part 4/09.90; yellow

Item No.: 216-108

Ferrule; Sleeve for 6 mm² / AWG 10; un-insulated; electro-tin plated; silver-colored

1.1.2 Jumper

1.1.2.1 Jumper



Item No.: 745-380

Jumper; 10-way; unplated; silver-colored



Item No.: 745-381

Jumper; 2-way; unplated; silver-colored



Item No.: 745-382

Jumper; 2-way; unplated; silver-colored



Item No.: 745-383

Jumper; 3-way; silver-colored



Item No.: 745-384

Jumper; 4-way; unplated; silver-colored



Item No.: 745-385

Jumper; 5-way; unplated; silver-colored

1.1.3 Test and measurement

1.1.3.1 Testing accessories



Item No.: 210-136

Test plug; 2 mm Ø; with 500 mm cable; red

Installation Notes

Conductor termination

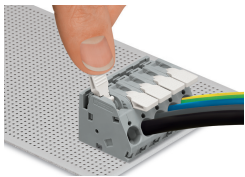

To open the clamping unit, pull the operating lever all the way back — 2706 and 2716 Series.

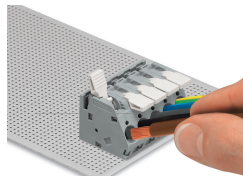

Inserting/removing a conductor – 2706 and 2716 Series.

Testing

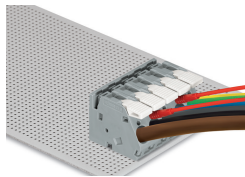

Testing with test plug – 2706 and 2716 Series.

Commoning

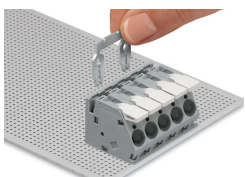

Inserting a comb-style jumper bar.

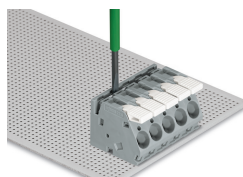

Push jumper bar down firmly using a screwdriver until it hits the backstop – 2706 and 2716 Series.

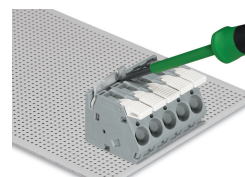

To remove the comb-style jumper bar, lift it up using a screwdriver – 2706 and 2716 Series.

Subject to changes. Please also observe the further product documentation!

Current addresses can be found at: www.wago.com