

PART NUMBER	ITEM ① BODY	ITEM ② CONTACT	ITEM ③ INSULATOR	ITEM ④ COUPLING NUT	ITEM ⑤ RETENTION SPRING	ITEM ⑥ SEAL GASKET
138-4693-001	BRASS GOLD PL .00001 MIN OVER NICKEL PL .0005 MIN OVER COPPER PL .00005 MIN	BRASS GOLD PL .00005 MIN OVER NICKEL PL .00005 MIN OVER COPPER PL .00005 MIN	TEFLON	BRASS TRI-ALLOY PL .0001 MIN	BERYLLIUM COPPER UNPLATED	SILICONE RUBBER
138-4693-007	BRASS TRI-ALLOY PL .0001 MIN	BRASS GOLD PL .00005 MIN OVER NICKEL PL .00005 MIN OVER COPPER PL .00005 MIN	TEFLON	BRASS TRI-ALLOY PL .0001 MIN	BERYLLIUM COPPER UNPLATED	SILICONE RUBBER

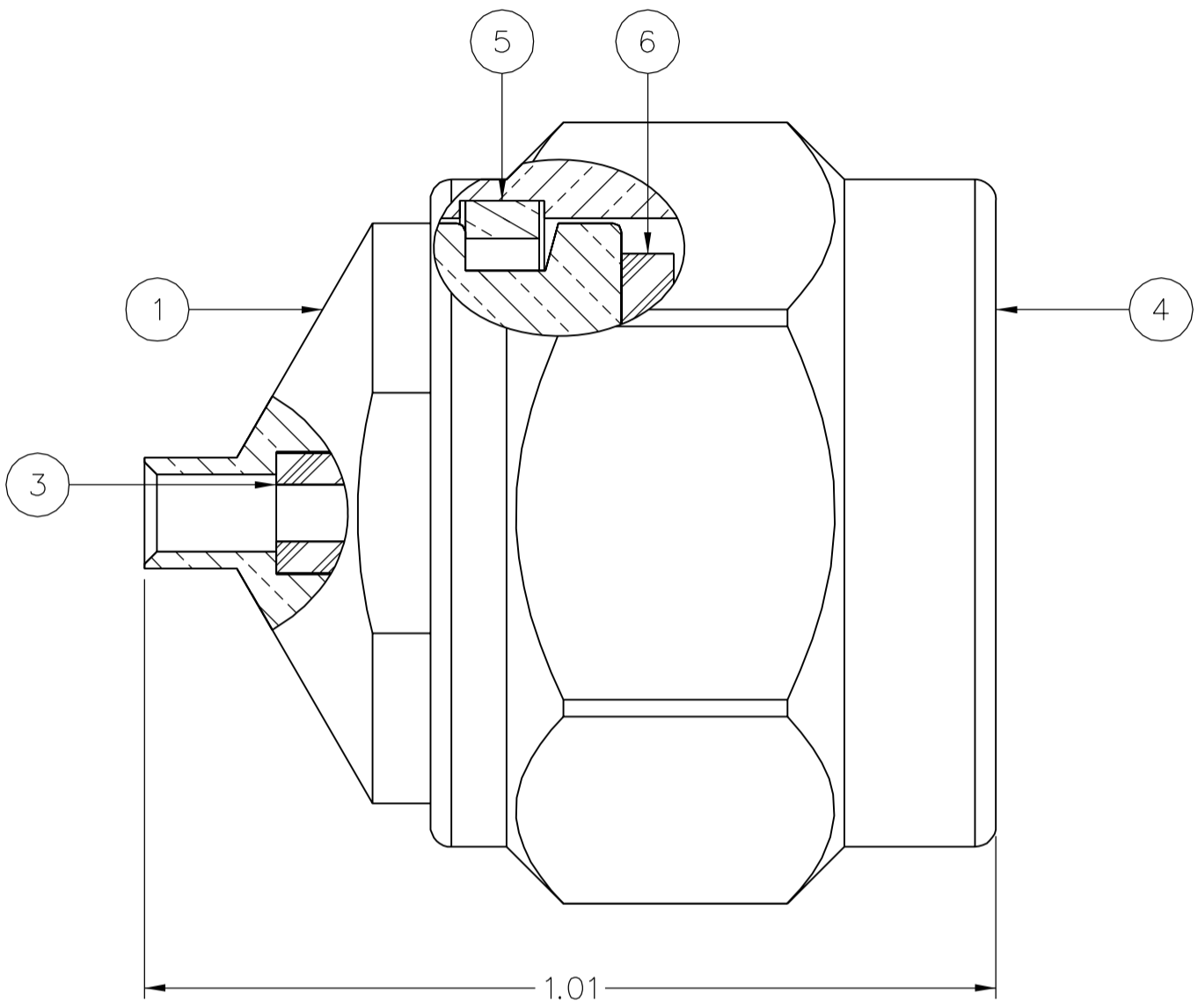
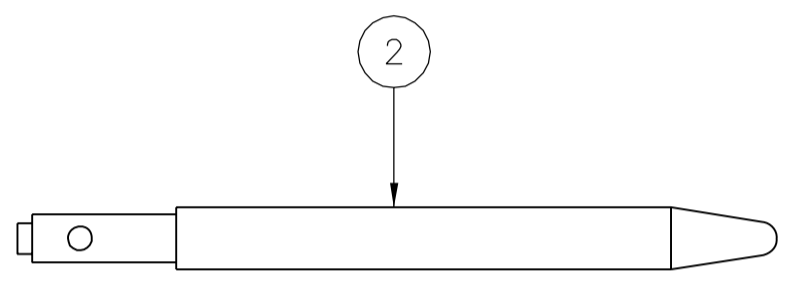
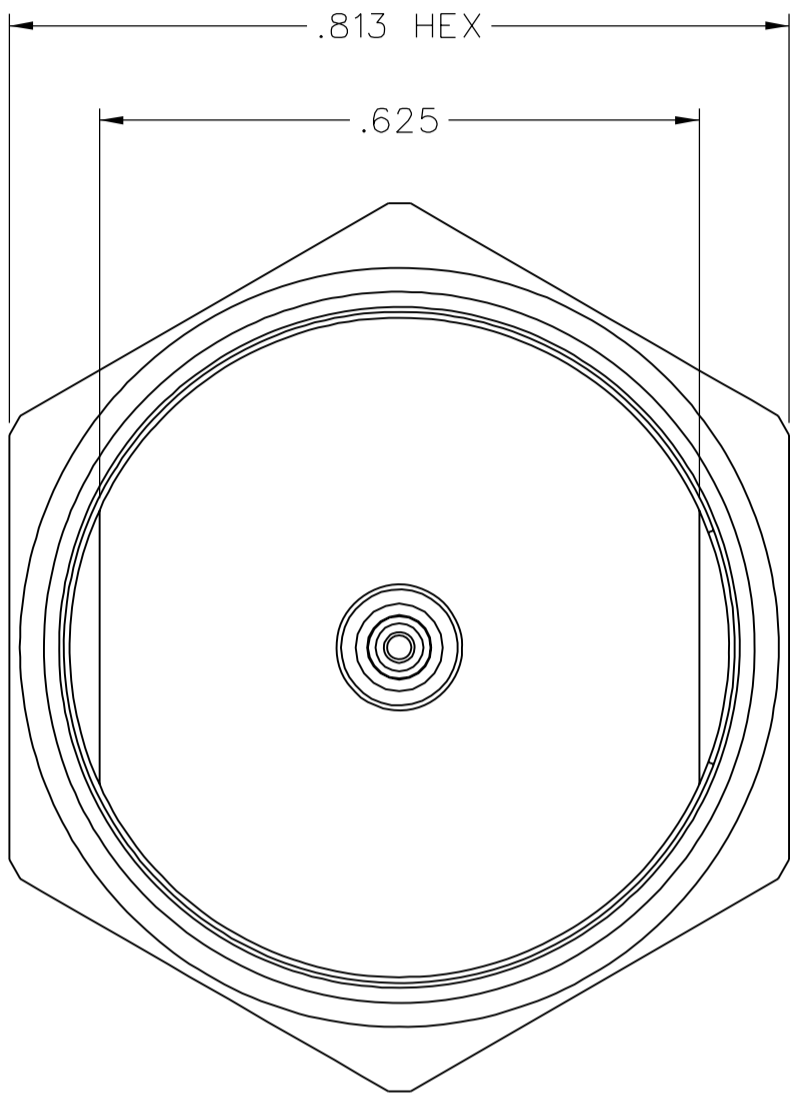
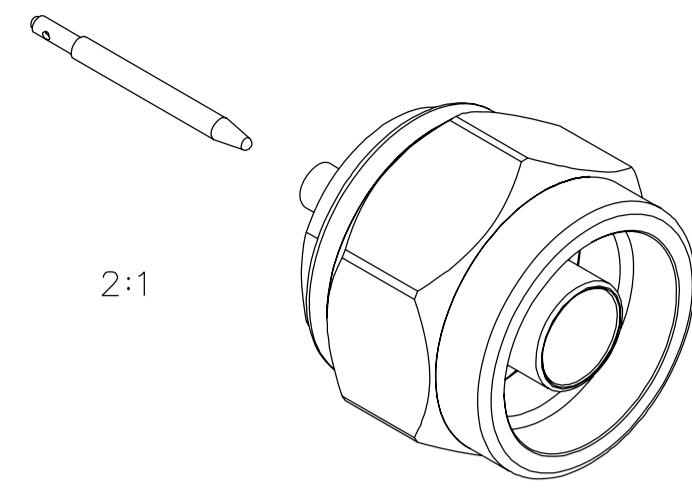

NOTES:

1. SPECIFICATIONS:
- IMPEDANCE: 50 OHMS
 - FREQUENCY RANGE: 0-18 GHz
 - VSWR: 1.07+.01F (GHz) MAX AT 0-11 GHz, TYPICALLY < 1.25 AT 11-18 GHz
 - WORKING VOLTAGE: 335 VRMS MAX AT SEA LEVEL
 - DIELECTRIC WITHSTANDING VOLTAGE: 1000 VRMS MIN AT SEA LEVEL
 - INSULATION RESISTANCE: 5000 MEGOHM MIN
 - CONTACT RESISTANCE:
 - CENTER CONTACT - INITIAL 1.0 MILLIOHM MAX, AFTER ENVIRONMENTAL 1.5 MILLIOHM MAX
 - OUTER CONDUCTOR - INITIAL 0.2 MILLIOHM MAX, AFTER ENVIRONMENTAL NOT APPLICABLE
 - CORONA LEVEL: 250 VOLTS MIN AT 70,000 FEET
 - INSERTION LOSS: $.05\sqrt{F}$ (GHz), TESTED AT 9 GHz
 - RF LEAKAGE: -90 dB MIN AT 2 TO 3 GHz
 - RF HIGH POTENTIAL WITHSTANDING VOLTAGE: 670 VRMS AT 4 AND 7 MHz
 - THIRD ORDER INTERMODULATION PRODUCT (IMP3): TYPICALLY < -90 dBm (TESTED PER IEC GUIDELINES WITH 20W CW INPUTS AT 1930-1990 MHz)

MECHANICAL:

- ENGAGE/DISENGAGE TORQUE: 6 IN-LBS MAX
- MATING TORQUE: 7-10 IN-LBS
- COUPLING PROOF TORQUE: 15 IN-LBS MIN
- COUPLING NUT RETENTION: 100 LBS MIN
- CONTACT RETENTION: NOT APPLICABLE
- CABLE ACCEPTABILITY: RG405, .086 OD SEMIRIGID
- CABLE HEX CRIMP SIZE: NOT APPLICABLE
- CABLE RETENTION: 30 LBS MIN AXIAL FORCE
- DURABILITY: 500 CYCLES MIN

ENVIRONMENTAL:

- (MEETS OR EXCEEDS THE APPLICABLE PARAGRAPH OF MIL-PRF-39012)
- THERMAL SHOCK: MIL-STD-202, METHOD 107, CONDITION B, EXCEPT 85°C HIGH TEMP
- OPERATING TEMPERATURE: -65°C TO 165°C
- CORROSION: MIL-STD-202, METHOD 101, CONDITION B
- SHOCK: MIL-STD-202, METHOD 213, CONDITION I
- VIBRATION: MIL-STD-202, METHOD 204, CONDITION B
- MOISTURE RESISTANCE: MIL-STD-202, METHOD 106

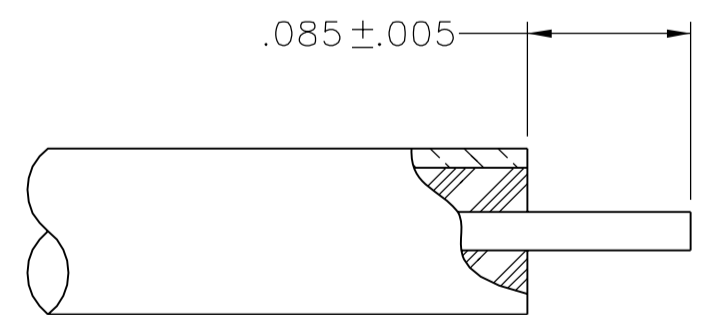

CABLE STRIP DIMENSIONS
10:1

DRAWING NO.
C - 138-4693-001/010

REVISIONS						
0	ENGINEERING RELEASE					
1	10-11-05	P A T	J R K	P D W	M J U	4-7-06 ECN 49930
DELETE: BODY TO CABLE - 0.05 MILLIOHM MAX.						
* REVISION NUMBER FOLLOWED BY AN ALPHA *						
* CHARACTER INDICATES DRAWING CLARIFI-						
* CATION OR PART NUMBER ADDITION ONLY. *						
1a	9-15-06	P A T	J R K	P D W	M J U	9-21-06 ECN 50623

CUSTOMER DRAWING

THIS DRAWING TO BE INTERPRETED
PER ASME Y 14.5M - 1994

"μSTATION"

COMPANY CONFIDENTIAL

TOLERANCE UNLESS OTHERWISE SPECIFIED		DRAWN BY	DATE
DECIMALS	mm	JRK	10-10-05
.XX REF	_____	CHECKED BY	DATE
.XXX REF	_____	PDW	4-6-06
MATL	_____	APPROVED BY	DATE
FINISH	_____	JRK	4-6-06
		RELEASE DATE	4-7-06
		U/M	INCH SCALE 5:1

Cinch Connectivity Solutions
P.O. Box 1732
Waseca, MN 56093
1-800-247-8256

TITLE
STRAIGHT SOLDER PLUG,
TYPE N CONNECTOR,
RG405 (.086) SEMI-RIGID

SHEET 2 OF 2
DRAWING NO.
C - 138-4693-001/010