

This document is the property of Amphenol Corporation and is delivered on the express condition that is not to be disclosed, reproduced or used, in whole or in part, for manufacture or sale by anyone other than Amphenol Corporation without its prior consent, and that no right is granted to disclose or to use any information in this document.

The marking on this product doesn't contain environmental hazardous materials per Material Specification 55-00259 for Sony GP compliant or per directive 2002/95/EC for RoHS compliant.



ORIGINAL



REVISIONS				
SYM	ECN No.	DESCRIPTION	DATE	APPROVED
A		RELEASE REVISION	05/12/2011	Roger Tsai
B	NE-12045	MODIFIED DRAWING	04/27/2012	Roger Tsai

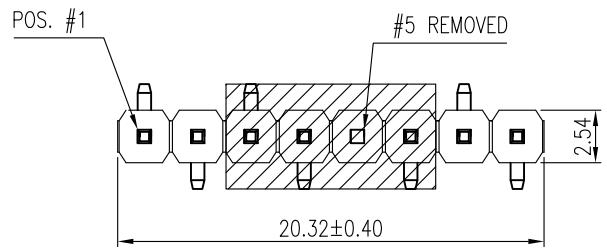
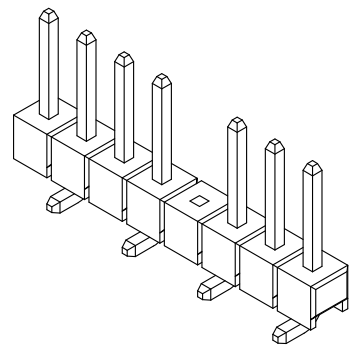

PART NO. G800MR300XXX5EU

- CONTACT FINISH  
 005- 15 u" GOLD  
 010- 30 u" GOLD  
 018- GOLD FLASH  
 025- 5 u" GOLD

NOTES:

- MATERIAL:  
HOUSING: HIGH TEMPERATURE THERMAL PLASTIC, LCP, UL94V-0, COLOR: BLACK.  
TERMINAL: COPPER ALLOY.
- FINISH:  
TERMINAL:  
CONTACT AREA: SELECTIVE GOLD PLATING THICKNESS MIN.;  
SOLDERING AREA: GOLD FLASH PLATING THICKNESS MIN.;  
UNDER PLATING: NICKEL PLATING 50 u" THICKNESS MIN. OVERALL.
- PACKING IS PER AMTA PACKING SPECIFICATION PKS-0001.
- THIS PRODUCT DOESN'T CONTAIN ENVIRONMENTAL HAZARDOUS PER DIRECTIVE 2002/95/EC FOR RoHS COMPLIANT.

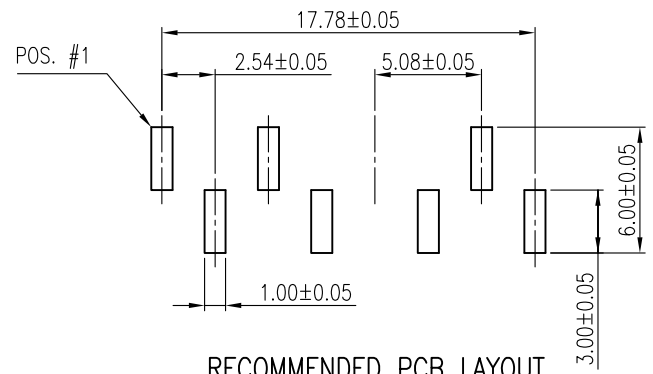
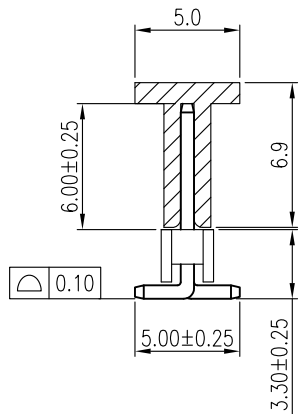
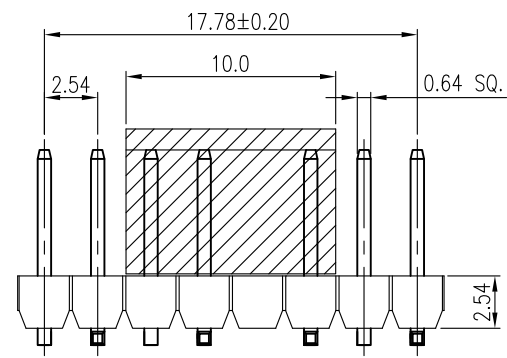

TOLERANCE		APPROVALS		DATE	TITLE		Amphenol®							
X.		DRAWN	Aqua Chou	04/27/2012	G800 SERIES PIN HEADER SINGLE ROW, 2.54 PITCH VERTICAL SMT, #5 REMOVED		Amphenol Corporation Amphenol Taiwan Corporation							
X.X	±0.30	CHECKED	Roger Tsai	04/27/2012										
X.XX	±0.20	APPROVED	Roger Tsai	04/27/2012										
X.XXX	±0.10						UNIT	mm	SIZE	A3	PART No.	G800MR300XXX5EU		
ANGULAR	±1°						SCALE	NA	SHEET	1 OF 3	DWG No.	G800MR300XXX5EU	REV.	B
UNLESS OTHERWISE SPECIFIED		DWG TYPE		CUST DWG	PROJECT CODE		HEAD							

This document is the property of Amphenol Corporation and is delivered on the express condition that is not to be disclosed, reproduced or used, in whole or in part, for manufacture or sale by anyone other than Amphenol Corporation without its prior consent, and that no right is granted to disclose or to use any information in this document.

The marking on this product doesn't contain environmental hazardous materials per Material Specification SS-00259 for Sony GP compliant or per directive 2002/95/EC for RoHS compliant.



ORIGINAL



REVISIONS				
SYM	ECN No.	DESCRIPTION	DATE	APPROVED
A		RELEASE REVISION	05/12/2011	Roger Tsai
B	NE-12045	MODIFIED DRAWING	04/27/2012	Roger Tsai

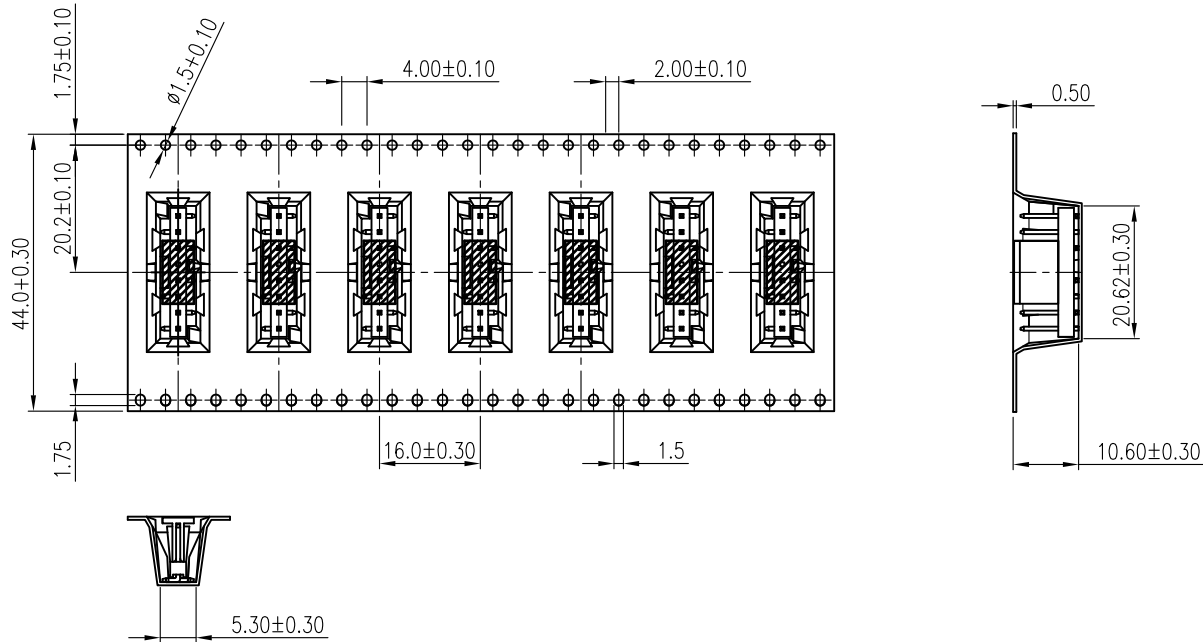

1. COMPONENT LOAD PER 13" REEL: 350 PCS (REF.)
2. PACKING LENGTH PER 13" REEL: 6.2 METER

TOLERANCE		APPROVALS		DATE	TITLE		Amphenol®				
X.		DRAWN		Aqua Chou	04/27/2012	G800 SERIES PIN HEADER SINGLE ROW, 2.54 PITCH VERTICAL SMT, #5 REMOVED	Amphenol Corporation Amphenol Taiwan Corporation				
X.X	±0.30	CHECKED		Roger Tsai	04/27/2012		PART No. G800MR300XX5EU				
X.XX	±0.20	APPROVED		Roger Tsai	04/27/2012		UNIT	mm	SIZE	A3	
X.XXX	±0.10	DWG TYPE		CUST DWG	PROJECT CODE		HEAD	SCALE	NA	SHEET	2 OF 3
ANGULAR	±1°	UNLESS OTHERWISE SPECIFIED						DWG No.	G800MR300XX5EU	REV.	B

This document is the property of Amphenol Corporation and is delivered on the express condition that is not to be disclosed, reproduced or used, in whole or in part, for manufacture or sale by anyone other than Amphenol Corporation without its prior consent, and that no right is granted to disclose or to use any information in this document.  
 The marking on this product doesn't contain environmental hazardous materials per Material Specification 55-00259 for Sony GP compliant or per directive 2002/95/EC for RoHS compliant.



ORIGINAL

SYMBOL		REVISIONS	DATE	APPROVED
A	ECN No.	DESCRIPTION		
		RELEASE REVISION	05/12/2011	Roger Tsai
B	NE-12045	MODIFIED DRAWING	04/27/2012	Roger Tsai

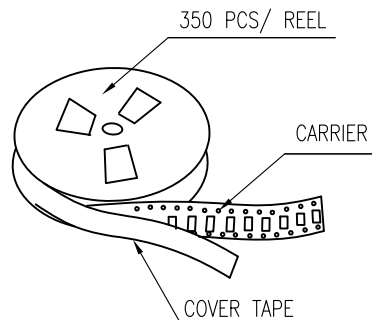
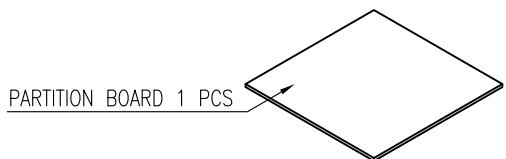
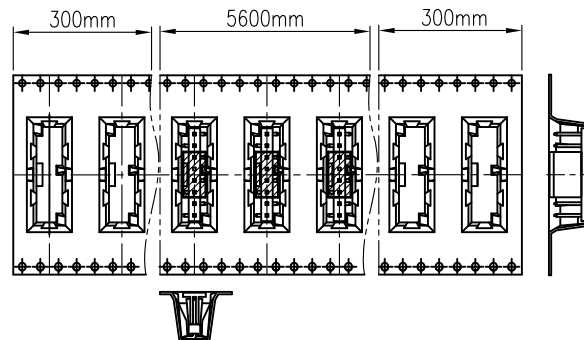

TRIANGLE BOARD 4 PCS

SHIPPING CARTON

5 REELS/ SHIPPING CARTON

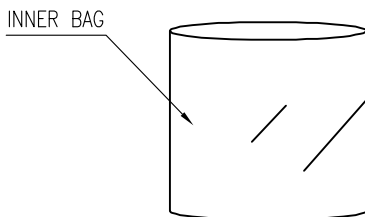
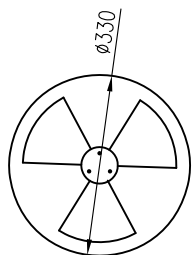
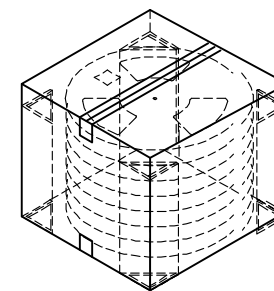
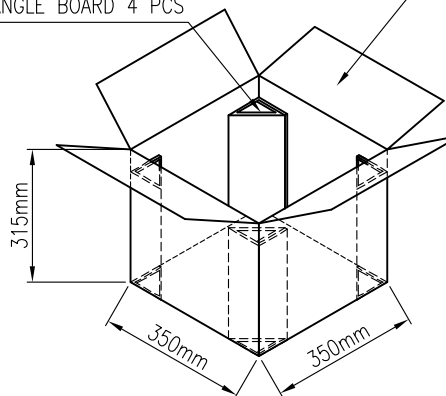
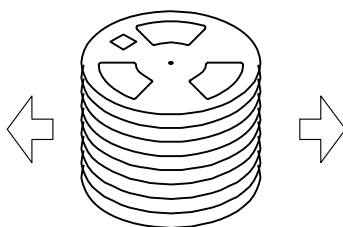

G800MR300XXX5EU	350	5	1750	4.5	3.2
PART NUMBER	PCS/ REEL	REEL/ BOX	QUANTITY (PCS)	G/W (KG)	N/W (KG)

PART NUMBER

TOLERANCE	APPROVALS	DATE	TITLE	UNIT	SIZE	PART No.
X. ±0.30	DRAWN Aqua Chou	04/27/2012	G800 SERIES PIN HEADER SINGLE ROW, 2.54 PITCH VERTICAL SMT, #5 REMOVED	mm	A3	G800MR300XXX5EU
X.X ±0.20	CHECKED Roger Tsai	04/27/2012		NA	3 OF 3	G800MR300XXX5EU
X.XXX ±0.10	APPROVED Roger Tsai	04/27/2012				
ANGULAR ±1°	DWG TYPE CUST DWG	PROJECT CODE HEAD				REV. B
UNLESS OTHERWISE SPECIFIED						

**Amphenol**<sup>®</sup>  
 Amphenol Corporation  
 Amphenol Taiwan Corporation

