



STK672-120

Unipolar Fixed-Current Chopper (Self-Excited PWM) Scheme and Built-in Phase Signal Distribution IC Two-Phase Stepping Motor Driver (Square Wave Drive) Output Current: 2.4 A

Overview

The STK672-120 is a unipolar fixed-current chopper type 2-phase stepping motor driver hybrid IC. It features power MOSFETs in the output stage and a built-in phase signal distribution IC. The incorporation of a phase distribution IC allows the STK672-120 to control the speed of the motor based on the frequency of an external input clock signal. It supports two types of excitation for motor control: 2-phase excitation and 1-2 phase excitation. It also provides a function for switching the motor direction.

Applications

- Two-phase stepping motor drive in send/receive facsimile units
- Paper feed in copiers, industrial robots, and other applications that require 2-phase stepping motor drive

Features

- The motor speed can be controlled by the frequency of an external clock signal (the CLOCK pin signal).
- The excitation type is switched according to the state (low or high) of the MODE pin. The mode is set to 2-phase or 1-2 phase excitation on the rising edge of the clock signal.
- A motor direction switching pin (the CWB pin) is provided.

- All input are Schmitt inputs and 40-k Ω (typical: -50 to +100%) pull-up resistors are built in.
- The motor current can be set by changing the Vref pin voltage. Since a 0.165- Ω current detection resistor is built in, a current of 1 A is set for each 0.165 V of applied voltage.
- The input frequency range for the clock signal used for motor speed control is 0 to 25 kHz.
- Supply voltage ranges: $V_{CC1} = 10$ to 42 V, $V_{CC2} = 5.0$ V $\pm 5\%$
- This IC supports motor operating currents of up to 2.4 A at $T_c = 105^\circ\text{C}$, and of up to 4.0 A at $T_c = 25^\circ\text{C}$.

Package Dimensions

unit: mm

4167

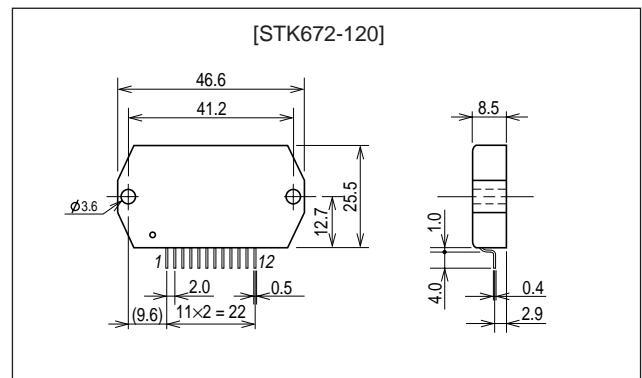

■ Any and all SANYO products described or contained herein do not have specifications that can handle applications that require extremely high levels of reliability, such as life-support systems, aircraft's control systems, or other applications whose failure can be reasonably expected to result in serious physical and/or material damage. Consult with your SANYO representative nearest you before using any SANYO products described or contained herein in such applications.

■ SANYO assumes no responsibility for equipment failures that result from using products at values that exceed, even momentarily, rated values (such as maximum ratings, operating condition ranges, or other parameters) listed in products specifications of any and all SANYO products described or contained herein.

SANYO Electric Co.,Ltd. Semiconductor Business Headquarters

TOKYO OFFICE Tokyo Bldg., 1-10, 1 Chome, Ueno, Taito-ku, TOKYO, 110-8534 JAPAN

12299RM(OT) No. 6042-1/9

Specifications

Maximum Rating at Ta = 25°C

Parameter	Symbol	Conditions	Ratings	Unit
Maximum supply voltage 1	V _{CC} max	No signal	52	V
Maximum supply voltage 2	V _{DD} max	No signal	-0.3 to +7.0	V
Input voltage	V _{IN} max	Logic input pins	-0.3 to +7.0	V
Output current	I _{OH} max	V _{DD} = 5 V, CLOCK ≥ 200 Hz	4.0	A
Repeated avalanche capacity	Ear max		36	mJ
Allowable power dissipation	Pd max	With an arbitrarily large heat sink. Per MOSFET	8.5	W
Operating substrate temperature	Tc max		105	°C
Junction temperature	Tj max		150	°C
Storage temperature	Tstg		-40 to +125	°C

Allowable Operating Ranges at Ta = 25°C

Parameter	Symbol	Conditions	Ratings	Unit
Maximum supply voltage 1	V _{CC}	With signals applied	10 to 42	V
Maximum supply voltage 2	V _{DD}	With signals applied	5.0 ± 5%	V
Input voltage	V _{IH}		0 to V _{DD}	V
Phase current 1	I _{OH1}	Tc = 105°C, CLOCK ≥ 200 Hz	2.4	A
Phase current 2	I _{OH2}	Tc = 80°C, CLOCK ≥ 200 Hz See the motor current (I _{OH}) derating curve	3.0	A
Clock frequency	f _{CL}	Minimum pulse width: 20 μs	0 to 25	kHz
Phase driver withstand voltage	V _{DSS}	I _D = 1 mA (Tc = 25°C)	100 min	V

Electrical Characteristics at Ta = 25°C, V_{CC} = 24 V, V_{DD} = 5 V

Parameter	Symbol	Conditions	Ratings			Unit
			min	typ	max	
V _{DD} supply current	I _{CCO}	CLOCK = GND		2.6	6	mA
Output current	I _{oave}	With R/L = 3 Ω/3.8 mH in each phase V _{ref} = 0.176 V	0.56	0.62	0.69	A
FET diode forward voltage	V _{df}	I _f = 1 A (R _L = 23 Ω)		1.1	1.7	V
Output saturation voltage	V _{sat}	R _L = 23 Ω		0.40	0.56	V
High-level input voltage	V _{IH}	Pins 6 to 9 (4 pins)	4.0			V
Low-level input voltage	V _{IL}	Pins 6 to 9 (4 pins)			1.0	V
Input current	I _{IL}	With pins 6 to 9 at the ground level. Pull-up resistance: 40 kΩ (typical)	62	125	250	μA
V _{ref} input voltage	V _{rH}	Pin 12	0		3.5	V
V _{ref} input bias current	I _{IB}	With pin 12 at 1 V		50	500	nA

Note: A fixed-voltage power supply must be used.

Internal Equivalent Circuit Block Diagram

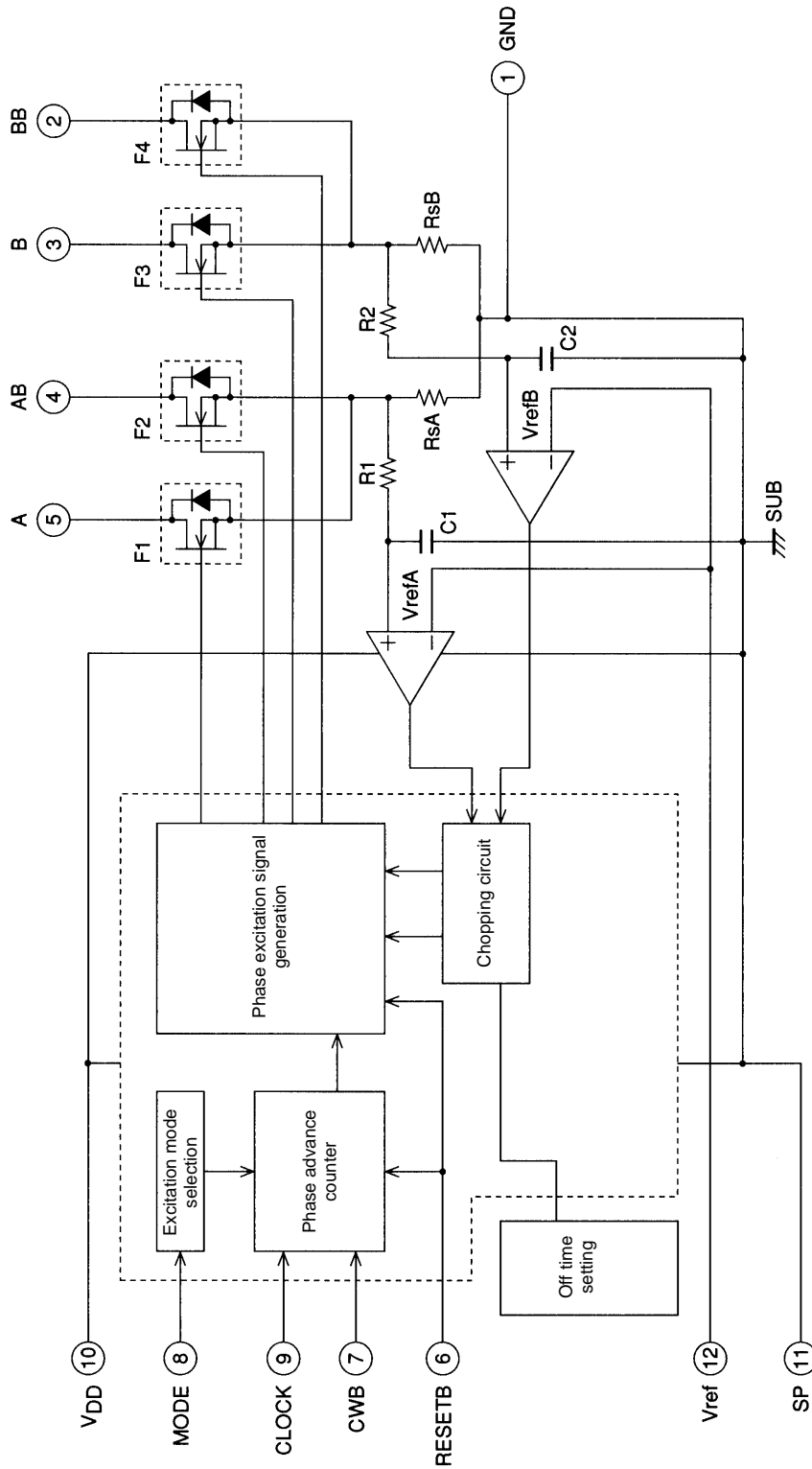

A11818

Sample Application Circuit

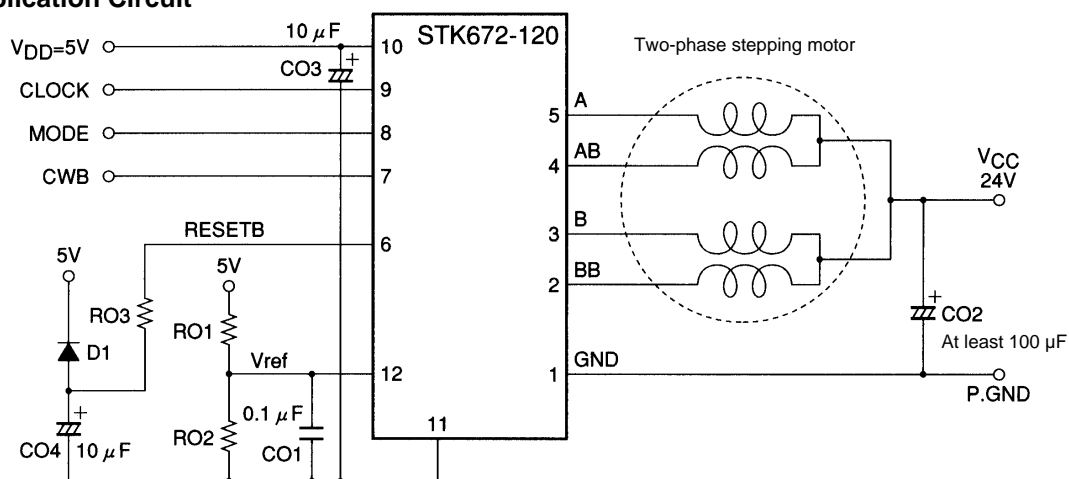

A11819

- To minimize noise in the 5-V system, locate the ground side of capacitor CO2 in the above circuit as close as possible to pin 1 of the IC.
- Insert resistor RO3 (47 to 100 Ω) so that the discharge energy from capacitor CO4 is not directly applied to the CMOS IC in this hybrid device. If the diode D1 has Vf characteristics with Vf less than or equal to 0.6 V (when If = 0.1 A), this will be smaller than the CMOS IC input pin diode Vf. If this is the case RO3 may be replaced with a short without problem.
- Standard or HC type input levels are used for the pin 7, 8, and 9 inputs.
- If open-collector type circuits are used for the pin 7, 8, and 9 inputs, these circuit will be in the high-impedance state for high level inputs. As a result, chopping circuit noise may cause the input circuits to operate incorrectly. To prevent incorrect operation due to such noise, capacitors with values between 470 and 1000 pF must be connected between pins 7 and 11, 8 and 11, and 9 and 11. (A capacitor with a value between 470 and 1000 pF must be connected between pins 6 and 11 as well if an open-collector output IC is used for the RESETB pin (pin 6) input.)
- Taking the input bias current (I_{IB}) characteristics into account, the resistor RO1 must not exceed 100 kΩ.
- The following circuit (for a lowered current of over 0.2 A) is recommended if the application needs to temporarily lower the motor current. Here, a value of close to 100 kΩ must be used for resistor RO1 to make the transistor output saturation voltage as low as possible.

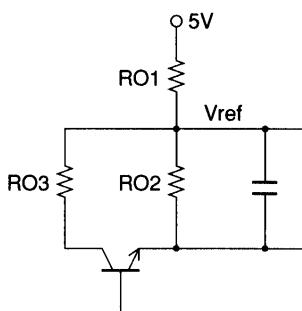

A11820

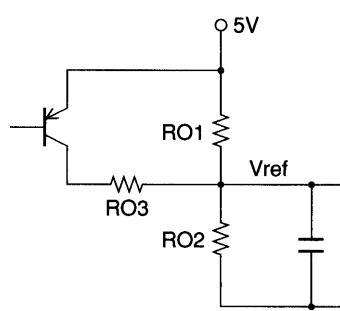

A11821

Input Pin Functions (CMOS input levels)

Pin	Pin No.	Function	Input conditions when operating
CLOCK	9	Reference clock for motor phase current switching	Operates on the rising edge of the signal
MODE	8	Excitation mode selection	Low: 2-phase excitation High: 1-2 phase excitation
CWB	7	Motor direction switching	Low: CW (forward) High: CCW (reverse)
RESETB	6	System reset and A, AB, B, and BB outputs cutoff. Applications must apply a reset signal for at least 20 µs when power is first applied.	A reset is applied by a low level

- A simple reset function is formed from D1, CO4, and RO3 in this application circuit. With the CLOCK input held low, when the 5-V supply voltage is brought up a reset is applied if the motor output phases A and BB are driven. If the 5-V supply voltage rise time is slow (over 50 ms), the motor output phases A and BB may not be driven. Increase the value of the capacitor CO4 and check circuit operation again.
- See the timing chart for the specific details on circuit operation.

Usage Notes

- 5-V system input pins

[RESETB and CLOCK (Input signal timing when power is first applied)]

As shown in the timing chart, a RESETB signal input is required by the driver to operate with the timing in which the F1 gate is turned on first. The RESETB signal timing must be set up to have a width of at least 20 μs, as shown below.

The capacitor CO4 and the resistor RO3 in the application circuit form simple reset circuit that uses the RC time constant rising time. However, when designing the RESETB input based on CMOS levels, the application must have the timing shown in figure 1.

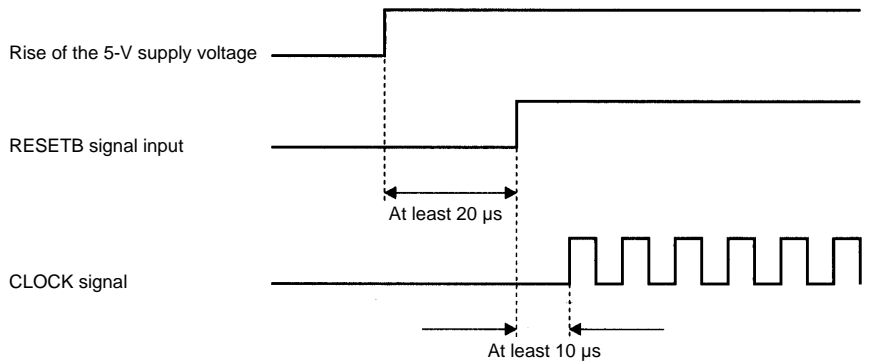

Figure 1 RESETB and CLOCK Signals Input Timing

See the timing chart for details on the CLOCK, MODE, CWB, and other input pins.

[Vref <Motor current peak value setting>]

In the sample application circuit, the peak value of the motor current (I_O) is set by RO1, RO2, and V_{DD} (5 V) as described by the formula below.

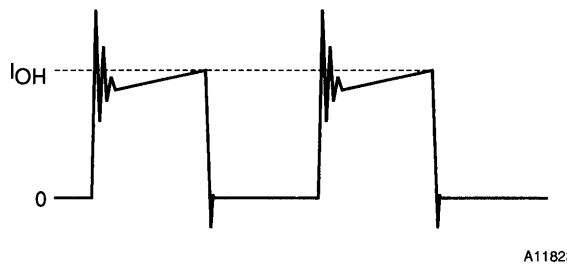

Figure 2 Motor Current I_O Flowing into the Driver IC

$I_{OH} = V_{ref} \div R_s$ Here, R_s is hybrid IC internal current detection resistor

$V_{ref} = (R02 \div (R01 + R02)) \times 5 \text{ V}$

STK672-120 : $R_s = 0.165 \Omega$

- Allowable motor current operating range

The motor current (I_O) must be held within the range corresponding to the area under the curve shown in figure 4.

For example, if the operating substrate temperature T_c is 105°C, then I_O must be held under $I_O \text{ max} = 2.4 \text{ A}$, and in hold mode I_O must be held under $I_O \text{ max} = 2.0 \text{ A}$.

• Thermal design

[Operating range in which a heat sink is not used]

Thermal design that lowers this hybrid IC’s operating substrate temperature can be effective in improving end product quality. The size of the heat sink required by this hybrid IC varies with the average power dissipation P_D . The value of P_D increases as the output current increases, as shown in figure 5.

Since there are periods when current flows and periods when the current is off during actual motor operation, P_D cannot be determined from the data presented in figure 5. Therefore, we calculate P_D assuming that actual motor operation consists of repetitions of the operation shown in figure 3.

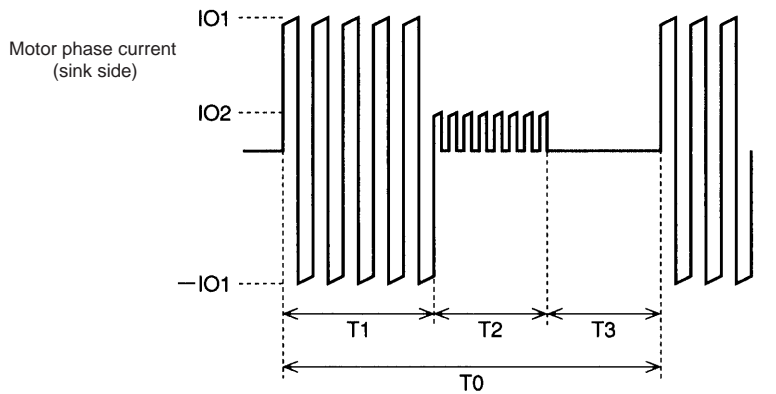

Figure 3 Motor Current Timing

A11824

T1: Motor rotation operation time

T2: Motor hold operation time

T3: Motor current off time

T2 may be reduced, depending on the application.

T0: Single repeated motor operating cycle

IO1 and IO2: Motor current peak values

Due to the structure of motor windings, the phase current is a positive and negative current with a pulse form.

Note that figure 3 presents the concepts here, and that the on/off duty of the actual signals will differ.

The hybrid IC internal average power dissipation P_D can be calculated from the following formula.

$$P_D = (T1 \times P1 + T2 \times P2 + T3) \div T0 \quad (I)$$

(Here, P1 is the P_D for IO1 and P2 is the P_D for IO2)

If the value calculated in formula (I) above is under 1.5 W, then there will be no need to use a heat sink for ambient temperatures T_a up to 60°C. See figure 6 for operating substrate temperature rise data when a heat sink is not attached.

If a heat sink is to be used, to lower T_c if P_D increases, use formula (II) and the graph in figure 7 to determine the size of the heat sink.

$$\theta_{c-a} = (T_c \text{ max} - T_a) \div P_D \quad (II)$$

$T_{c \text{ max}}$: Maximum operating substrate temperature = 105°C

T_a : The hybrid IC ambient temperature

While formulas (I) and (II) above are adequate for thermal design, note that figure 5 is merely a single example of one operating mode for a single motor. For example, while figure 5 shows a 2-phase excitation motor, if 1-2 phase excitation is used with a 500-Hz clock frequency, the drive will be turned off for 25% of the time and the loss P_D will be reduced to 75% of that in figure 5.

It is extremely difficult for Sanyo to calculate the internal average power dissipation P_D for all possible end product conditions. After performing the above rough calculations, always install the hybrid IC in an actual end product and verify that the substrate temperature T_c does not rise above 105°C.

Timing Chart

2-phase excitation

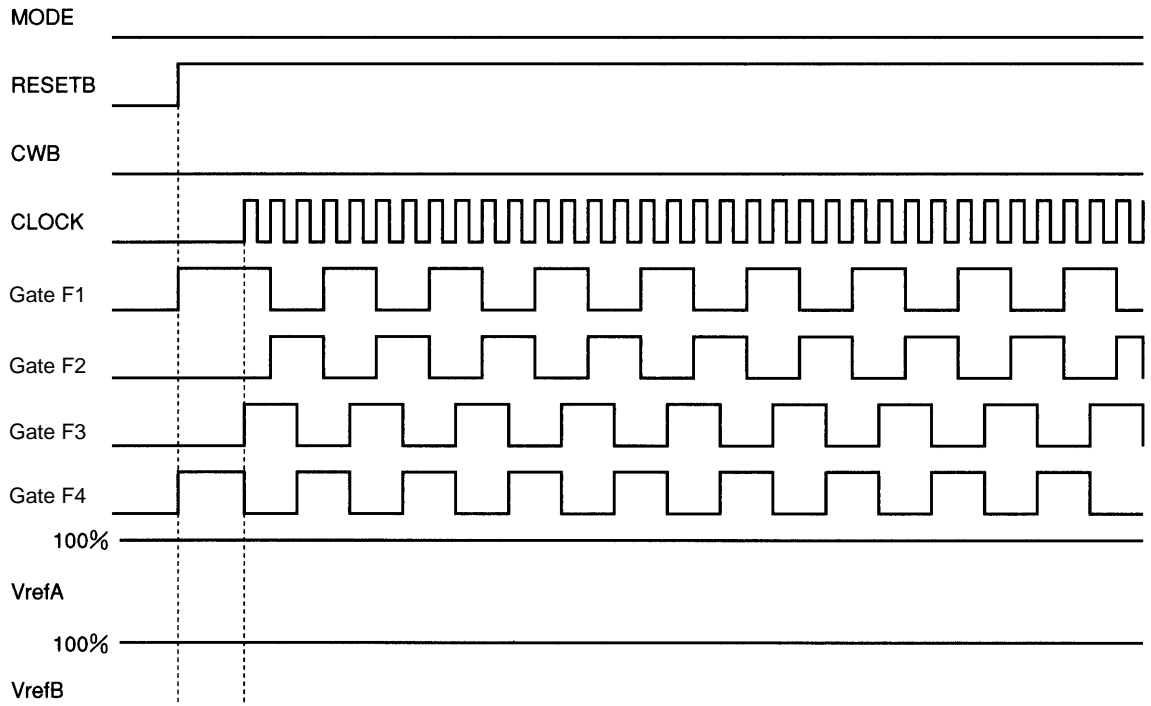

A11825

1-2 phase excitation

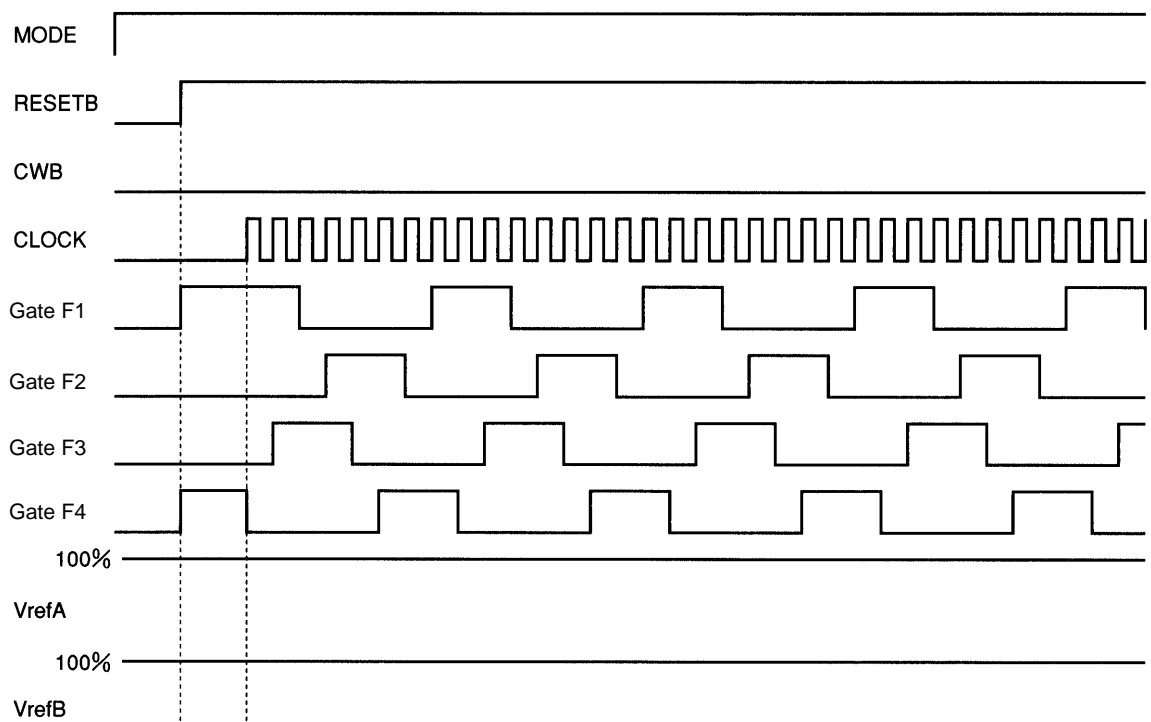

A11826

1-2 phase excitation (CWB)

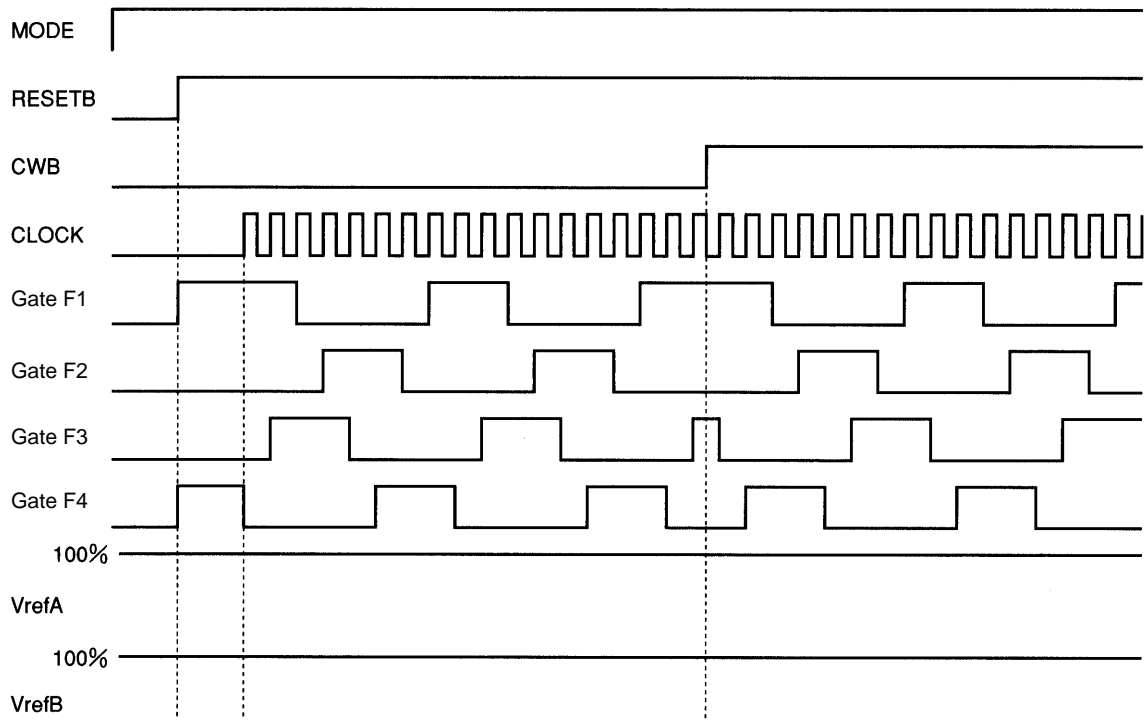

A11827

Switching from 2-phase to 1-2 phase excitation

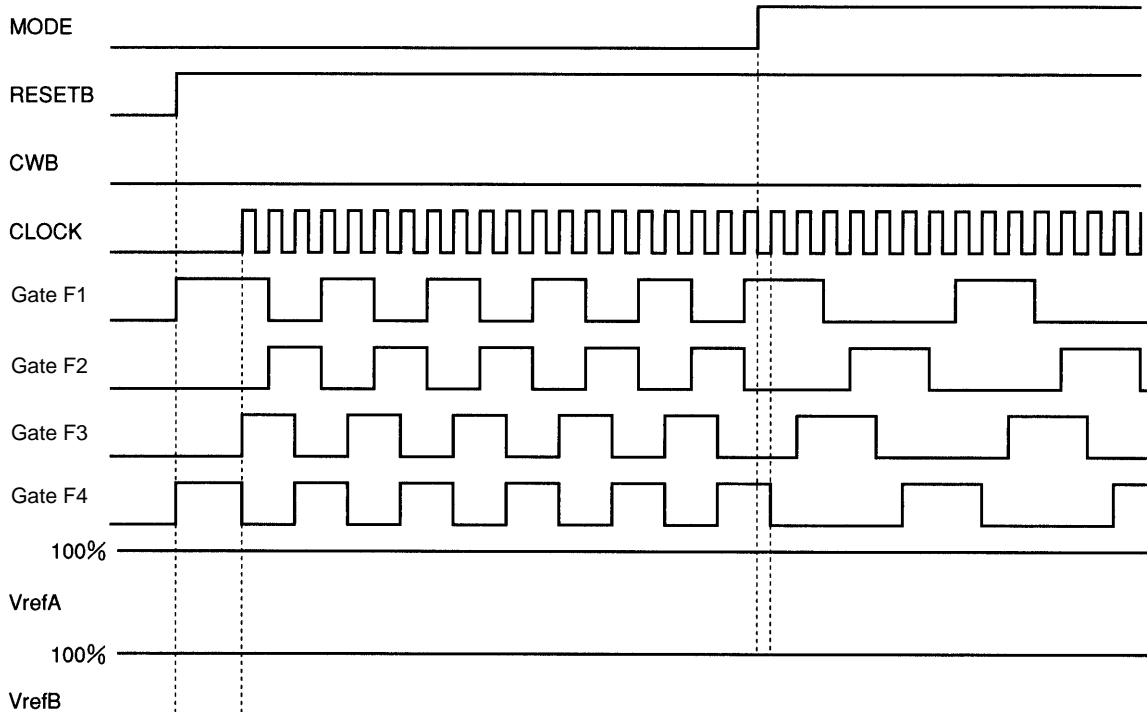

A11828

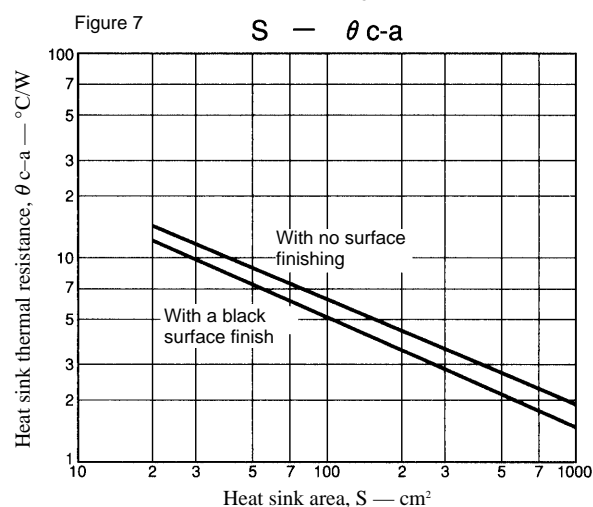
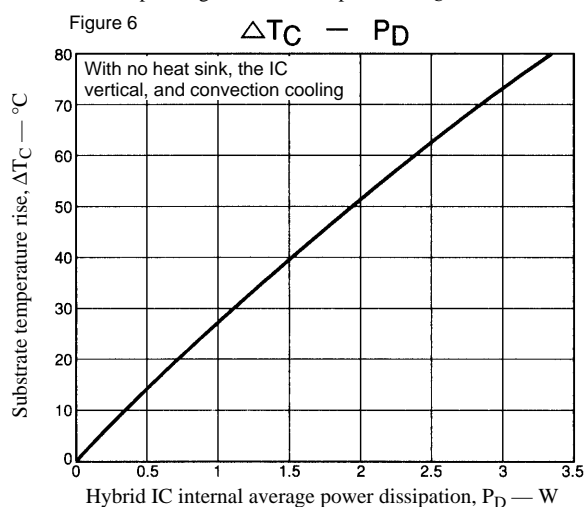
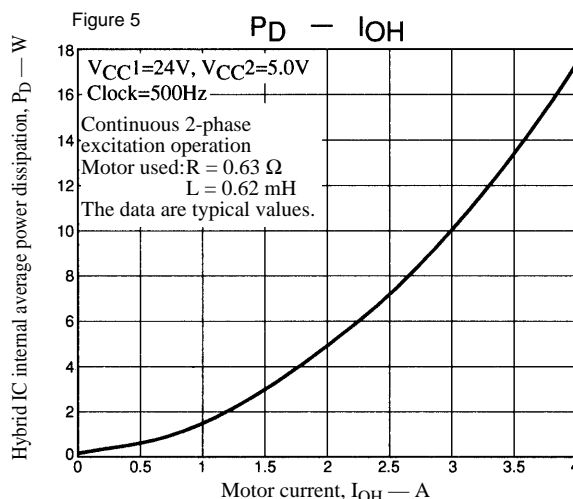
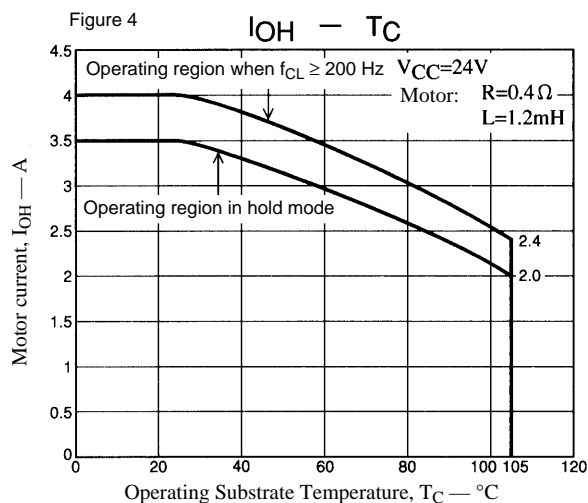

- Specifications of any and all SANYO products described or contained herein stipulate the performance, characteristics, and functions of the described products in the independent state, and are not guarantees of the performance, characteristics, and functions of the described products as mounted in the customer's products or equipment. To verify symptoms and states that cannot be evaluated in an independent device, the customer should always evaluate and test devices mounted in the customer's products or equipment.
- SANYO Electric Co., Ltd. strives to supply high-quality high-reliability products. However, any and all semiconductor products fail with some probability. It is possible that these probabilistic failures could give rise to accidents or events that could endanger human lives, that could give rise to smoke or fire, or that could cause damage to other property. When designing equipment, adopt safety measures so that these kinds of accidents or events cannot occur. Such measures include but are not limited to protective circuits and error prevention circuits for safe design, redundant design, and structural design.
- In the event that any or all SANYO products (including technical data, services) described or contained herein are controlled under any of applicable local export control laws and regulations, such products must not be exported without obtaining the export license from the authorities concerned in accordance with the above law.
- No part of this publication may be reproduced or transmitted in any form or by any means, electronic or mechanical, including photocopying and recording, or any information storage or retrieval system, or otherwise, without the prior written permission of SANYO Electric Co., Ltd.
- Any and all information described or contained herein are subject to change without notice due to product/technology improvement, etc. When designing equipment, refer to the "Delivery Specification" for the SANYO product that you intend to use.
- Information (including circuit diagrams and circuit parameters) herein is for example only; it is not guaranteed for volume production. SANYO believes information herein is accurate and reliable, but no guarantees are made or implied regarding its use or any infringements of intellectual property rights or other rights of third parties.

This catalog provides information as of January, 1999. Specifications and information herein are subject to change without notice.