

**Data Sheet | Item Number: 2061-603/998-404**  
 SMD PCB terminal block; push-button; 1.5 mm<sup>2</sup>; Pin spacing 6 mm; 3-pole; Push-in  
 CAGE CLAMP®; in tape-and-reel packaging; white



<https://www.wago.com/2061-603/998-404>



Color: ■ white

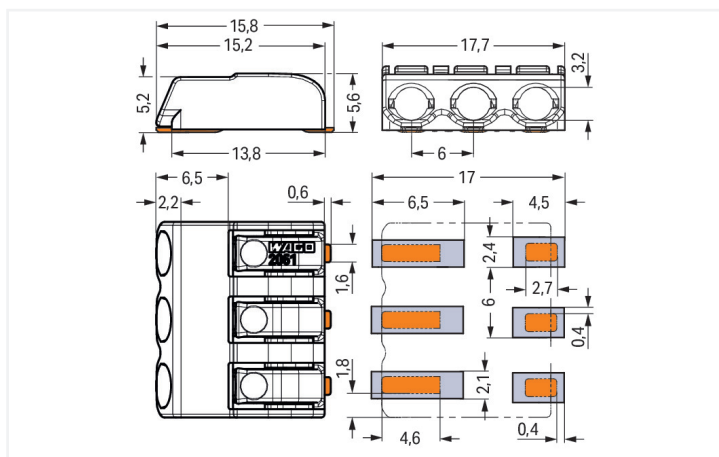
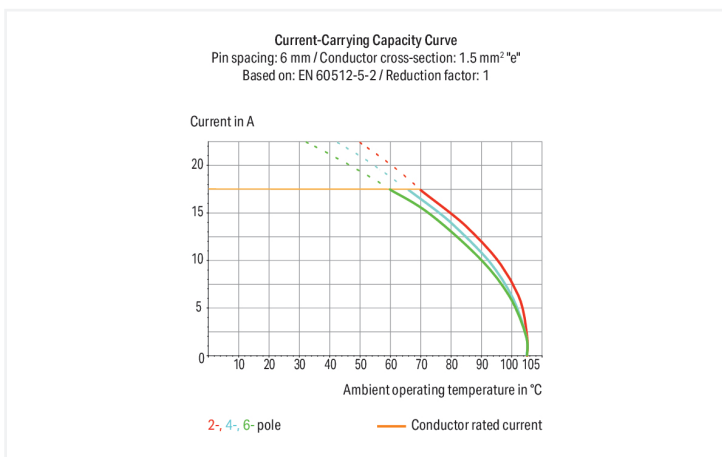

Dimensions in mm

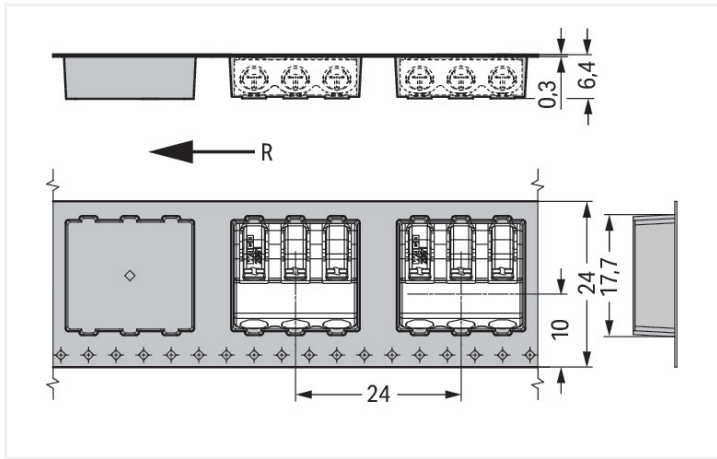

Dimensions in mm  
R = feed direction

PCB terminal block, 2061 Series, white

Quick and easy connections are guaranteed with this PCB terminal block (item number 2061-603/998-404). It offers the flexibility needed for different mounting types. Ensure that the strip lengths are between 7 and 10 mm when connecting conductors to this PCB terminal block. Featuring one conductor terminal along with Push-in CAGE CLAMP®, this product delivers reliable performance. Our Push-in CAGE CLAMP® is a universal, maintenance-free connection solution for all conductor types, featuring a winning design: It allows direct insertion of both solid and fine-stranded conductors with ferrules without needing tools. No preparation is required; for example, crimping the conductor's ferrule is not necessary. The item's dimensions are (17.7 x 5.6 x 15.8) mm (width x height x depth). Depending on the conductor type, this PCB terminal block is designed for conductor cross sections ranging from 0.25 mm² to 1.5 mm².

The contact surface is coated with tin. This PCB terminal block is operated with a push-button. SMD is used to solder the PCB terminal block. The conductor is designed to be inserted at an angle of 0°.

Notes	
Note	<p>Application notes: Suitable for lead-free, reflow-soldering profiles per DIN EN 61760-1 and IEC 60068-2-58 up to max. 260°C peak temperature. Due to application-specific variables (component configuration and orientation, type of soldering machine, solder paste), trial runs are recommended to ensure product and process compatibility under actual manufacturing conditions.</p> <p>Depending on reflow soldering temperatures and times, color deviations may occur. These deviations will have no impact on functionality.</p>
Recommendation	<p>Recommendation for stencil: 150 µm material thickness; Pattern layout identical to solder pad layout</p>

Electrical data							
Ratings per	IEC/EN 60664-1			Approvals per	UL 1059		
Overtoltage category	III	III	II	Use group	B	C	D
Pollution degree	3	2	2	Rated voltage	300 V	-	300 V
Nominal voltage	250 V	320 V	630 V	Rated current	10 A	-	10 A
Rated impulse withstand voltage	4 kV	4 kV	4 kV				
Rated current	17.5 A	17.5 A	17.5 A				

## Connection Data

Clamping units	3
Total number of potentials	3
Number of connection types	1
Number of levels	1

## Connection 1

Connection technology	Push-in CAGE CLAMP®
Actuation type	Push-button
Solid conductor	0.25 ... 1.5 mm <sup>2</sup> / 20 ... 16 AWG
Fine-stranded conductor	0.5 ... 1.5 mm <sup>2</sup> / 20 ... 16 AWG
Fine-stranded conductor; with insulated ferrule	0.5 ... 0.75 mm <sup>2</sup>
Fine-stranded conductor; with uninsulated ferrule	0.5 ... 0.75 mm <sup>2</sup>
Strip length	7 ... 10 mm / 0.28 ... 0.39 inches
Conductor connection direction to PCB	0°
Pole number	3

## Physical data

Pin spacing	6 mm / 0.24 inches
Width	17.7 mm / 0.697 inches
Height	5.6 mm / 0.22 inches
Height from the surface	5.6 mm / 0.22 inches
Depth	15.8 mm / 0.622 inches
Reel diameter of tape-and-reel packaging	330 mm
Tape width	24 mm

## PCB contact

PCB contact	SMD
Solder pin arrangement	over the entire terminal strip (in-line)
Number of solder pins per potential	2

## Material data

Note (material data)	<a href="#">Information on material specifications can be found here</a>
Color	white
Material group	I
Insulation material (main housing)	Polyphthalamide (PPA GF)
Flammability class per UL94	V0
Contact material	Copper alloy
Contact Plating	Tin
Fire load	0.012 MJ
Weight	1.6 g
MSL per J-STD 020D	1

## Environmental requirements

Limit temperature range	-60 ... +105 °C
-------------------------	-----------------

**Commercial data**

PU (SPU)	4050 (450) pcs
Packaging type	Box
Country of origin	CN
GTIN	4055143278041
Customs tariff number	85369010000

**Product Classification**

UNSPSC	39121409
eCl@ss 10.0	27-14-11-06
eCl@ss 9.0	27-14-11-06
ETIM 9.0	EC001284
ETIM 10.0	EC001284
ECCN	NO US CLASSIFICATION

**Environmental Product Compliance**

RoHS Compliance Status	Compliant, No Exemption
------------------------	-------------------------

**Approvals / Certificates**

**General approvals**



Approval	Standard	Certificate Name
CCA DEKRA Certification B.V.	EN 60947-7-4	NTR NL-7773
CCA DEKRA Certification B.V.	EN 60838	NTR NL-7721
cURus Underwriters Laboratories Inc.	UL 1059	E45172
KEMA/KEUR DEKRA Certification B.V.	EN 60838	71-106232

**Downloads**

**Environmental Product Compliance**

Compliance Search	
Environmental Product Compliance 2061-603/998-404	<a href="#">↓</a>

**Documentation**

Additional Information			
Technical Section	03.04.2019	pdf 2027.26 KB	<a href="#">↓</a>

**CAD/CAE-Data**

CAD data	
2D/3D Models 2061-603/998-404	<a href="#">↓</a>

CAE data	
ZUKEN Portal 2061-603/998-404	<a href="#">↓</a>

**PCB Design**

Symbol and Footprint via SamacSys 2061-603/998-404	<a href="#">↓</a>
Symbol and Footprint via Ultra Librarian 2061-603/998-404	<a href="#">↓</a>

**1 Compatible Products**

**1.1 Optional Accessories**

**1.1.1 Board-to-board link**

**1.1.1.1 Board-to-board link**



**Item No.: 2061-903**  
Board-to-Board Link; Pin spacing 6 mm;  
3-pole; Length: 30 mm; white

**Item No.: 2061-903/034-000**  
Board-to-Board Link; Pin spacing 6 mm;  
3-pole; Length: 34 mm; white

**1.1.2 Ferrule**

**1.1.2.1 Ferrule**



**Item No.: 216-201**  
Ferrule; Sleeve for 0.5 mm<sup>2</sup> / 20 AWG; in-  
sulated; electro-tin plated; electrolytic  
copper; acc. to DIN 46228, Part 4/09.90;  
white

**Item No.: 216-241**  
Ferrule; Sleeve for 0.5 mm<sup>2</sup> / 20 AWG; in-  
sulated; electro-tin plated; electrolytic  
copper; gastight crimped; acc. to DIN  
46228, Part 4/09.90; white

**Item No.: 216-141**  
Ferrule; Sleeve for 0.5 mm<sup>2</sup> / 20 AWG; un-  
insulated; electro-tin plated; electrolytic  
copper; gastight crimped; acc. to DIN  
46228, Part 1/08.92

**Item No.: 216-101**  
Ferrule; Sleeve for 0.5 mm<sup>2</sup> / AWG 22; un-  
insulated; electro-tin plated; silver-colo-  
red



**Item No.: 216-242**  
Ferrule; Sleeve for 0.75 mm<sup>2</sup> / 18 AWG; in-  
sulated; electro-tin plated; electrolytic  
copper; gastight crimped; acc. to DIN  
46228, Part 4/09.90; gray

**Item No.: 216-202**  
Ferrule; Sleeve for 0.75 mm<sup>2</sup> / 18 AWG; in-  
sulated; electro-tin plated; gray

**Item No.: 216-142**  
Ferrule; Sleeve for 0.75 mm<sup>2</sup> / 18 AWG;  
uninsulated; electro-tin plated; electroly-  
tic copper; gastight crimped; acc. to DIN  
46228, Part 1/08.92

**Item No.: 216-102**  
Ferrule; Sleeve for 0.75 mm<sup>2</sup> / AWG 20;  
uninsulated; electro-tin plated; silver-co-  
lored

### 1.1.3 Tool

#### 1.1.3.1 Operating tool



Item No.: [206-866](#)

Operating tool; for 2061 Series

Item No.: [2061-190](#)

Operating tool; made of insulating material

### Installation Notes

#### Conductor termination



Inserting solid conductors via push-in termination.

#### Conductor termination

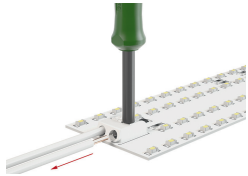

Easy conductor removal, e.g., via operating tool (206-861)